

TABLE OF CONTENTS

VISUAL INDEX

SAFETY INFORMATION

INSTRUMENT PANEL

VEHICLE CONTROLS

AUDIO AND CONNECTIVITY

BLUETOOTH® HANDSFREELINK®

ACURALINK®

Use this Owner's Guide for vehicles without software update (Ver. ST02)

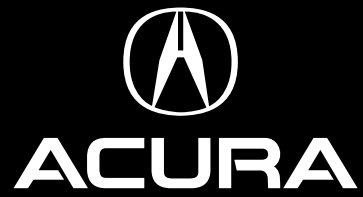

owners.acura.com (U.S.)
myacura.ca (Canada)

31TZ3G00
00X31-TZ3-G000

2015 Acura TLX Owner's Guide
©2014 Honda Motor Co., Ltd. — All Rights Reserved

Printed in U.S.A.



2015
OWNER'S GUIDE

NAVIGATION

DRIVING

HANDLING THE UNEXPECTED

MAINTENANCE

SPECIFICATIONS

CLIENT INFORMATION

VOICE COMMAND INDEX

INDEX

DISCLOSURES

■ Devices That Emit Radio Waves

The following products and systems on your vehicle emit radio waves when in operation:

- AcuraLink®
- Audio system
- Blind Spot Information (BSI)*
- Bluetooth® Audio
- Bluetooth® HandsFreeLink®
- Collision Mitigation Braking System™ (CMBS)*
- HomeLink® Universal Transceiver
- Immobilizer system
- Keyless Access System
- Remote transmitter
- Tire Pressure Monitoring System

Each of the above complies with the appropriate requirements or the required standards of FCC (Federal Communications Commission) and Industry Canada, described below:

As required by the FCC:

This device complies with Part 15 of the FCC rules. Operation is subject to the following two conditions: (1) This device may not cause harmful interference, and (2) this device must accept any interference received, including interference that may cause undesired operation.

Changes or modifications not expressly approved by the party responsible for compliance could void the user's authority to operate the equipment.

As required by Industry Canada:

This device complies with Industry Canada Standard RSS-Gen/210/310. Operation is subject to the following two conditions: (1) this device may not cause interference, and (2) this device must accept any interference, including interference that may cause undesired operation of the device.

■ California Perchlorate Contamination Prevention Act

The airbags, seat belt tensioners, and CR-type batteries in this vehicle may contain perchlorate materials — special handling may apply. See www.dtsc.ca.gov/hazardouswaste/perchlorate/ for more information.

■ California Proposition 65 Warning

WARNING: This product contains or emits chemicals known to the state of California to cause cancer and birth defects or other reproductive harm.

■ Event Data Recorders

This vehicle is equipped with an event data recorder (EDR). The main purpose of an EDR is to record, in certain crash or near crash-like situations, such as an air bag deployment or hitting a road obstacle, data that will assist in understanding how a vehicle's systems performed. **The EDR is designed to record data related to vehicle dynamics and safety systems for a short period of time, typically 30 seconds or less. The EDR in this vehicle is designed to record such data as:**

- How various systems in your vehicle were operating;
- Whether or not the driver and passenger safety belts were buckled/ fastened;
- How far (if at all) the driver was depressing the accelerator and/or brake pedal; and,
- How fast the vehicle was traveling.

These data can help provide a better understanding of the circumstances in which crashes and injuries occur. NOTE: EDR data are recorded by your vehicle only if a non-trivial crash situation occurs; no data are recorded by the EDR under normal driving conditions and no personal data (e.g., name, gender, age, and crash location) are recorded. However, other parties, such as law enforcement, could combine the EDR data with the type of personally identifying data routinely acquired during a crash investigation.

To read data recorded by an EDR, special equipment is required, and access to the vehicle or the EDR is needed. In addition to the vehicle manufacturer, other parties such as law enforcement that have the special equipment can read the information if they have access to the vehicle or the EDR.

The data belong to the vehicle owner and may not be accessed by anyone else except as legally required or with the permission of the vehicle owner.

■ Service Diagnostic Recorders

This vehicle is equipped with service-related devices that record information about powertrain performance. The data can be used to verify emissions law requirements and/or help technicians diagnose and solve service problems. It may also be combined with data from other sources for research purposes, but it remains confidential.

INTRODUCTION

This Owner's Guide is intended to help you quickly get acquainted with your 2015 Acura TLX. It provides basic information and instructions on technology and convenience features, as well as emergency procedures and how to get assistance.

This guide is for vehicles sold in the United States and Canada. It covers all TLX models, so you may find descriptions of features and equipment that are not in your vehicle.

Images throughout this guide are from U.S. vehicles and represent features and equipment that are available on some, but not all, models. Images shown in this guide should be considered examples and used for demonstration purposes only.

This guide is not intended to be a substitute for the Owner's Manual. The Owner Information CD enclosed in your glove box kit includes the Owner's Manual, Navigation Manual, and vehicle and tire warranties in electronic format. This information can be viewed on a computer (PC or Mac platform) and saved or printed for your reference. You can also visit owners.acura.com to view the complete and most current information.

If you are the first registered owner of your vehicle, you may request a complimentary printed copy of the Owner's Manual, Navigation Manual, or Vehicle Warranty up to the first six months of vehicle purchase. To request a copy, visit owners.acura.com and create or log in to your account. In Canada, please request a copy from your Acura dealer.

American Honda Motor Company strives to be proactive in protecting our environment and natural resources. By using electronic delivery for a considerable portion of the information typically found in a vehicle owner's manual, we are further reducing our impact on the environment.

■ Acura Total Luxury Care Roadside Assistance

Your Acura TLC Roadside Assistance representative is here to help you 24 hours a day, 7 days a week. Under your 4-year/50,000-mile (80,000 km) warranty, the following benefits are available:

- Towing services — full cost of towing to the closest Acura dealer
- Roadside assistance — jump starting, fuel delivery, lockout, and flat tire
- Trip planning — detailed trip routing, emergency services, and more

Call (800) 594-8500 (U.S.) or (800) 565-7587 (Canada)

■ Acura Client Relations

Your authorized Acura dealer should be able to answer any questions you have about your vehicle. However, if you are dissatisfied with the information you receive, you can call Acura Client Relations (see page 132).

Call (800) 382-2238 (U.S.) or (888) 922-8729 (Canada)

TABLE OF CONTENTS

| | | | |
|--|----|---|----|
| VISUAL INDEX..... | 1 | AUDIO AND CONNECTIVITY | 44 |
| Steering Wheel and Nearby Controls..... | 1 | Basic Audio Operation..... | 44 |
| Dashboard and Ceiling Controls | 2 | FM/AM Radio | 47 |
| SAFETY INFORMATION..... | 3 | SiriusXM® Radio..... | 48 |
| Important Safety Information | 3 | Compact Disc (CD) | 49 |
| Seat Belts | 5 | iPod® or USB Flash Drive | 50 |
| Airbags..... | 8 | Bluetooth® Audio..... | 51 |
| Child Safety | 14 | Hard Disc Drive (HDD) Audio* | 52 |
| Safety Label Locations | 20 | Pandora® | 53 |
| Reporting Safety Defects..... | 21 | AcuraLink featuring Aha™ | 54 |
| INSTRUMENT PANEL | 22 | BLUETOOTH® HANDSFREELINK®..... | 55 |
| Malfunction Indicators..... | 22 | Basic HFL Operation | 55 |
| Condition Indicators..... | 24 | Pairing a Phone..... | 57 |
| On/Off Indicators | 25 | Making a Call | 58 |
| Multi-Information Display | 26 | SMS Text Messaging and E-Mail ... | 61 |
| VEHICLE CONTROLS..... | 27 | ACURALINK®* | 62 |
| Using the Remote Transmitter..... | 27 | AcuraLink Messages..... | 62 |
| Keyless Access System | 28 | Subscription Features..... | 63 |
| Door Operation from Inside the Vehicle | 29 | NAVIGATION* | 65 |
| Power Window Operation | 30 | Basic Navigation Operation | 65 |
| Power Moonroof Operation | 31 | Entering a Destination | 68 |
| Interior and Exterior Lights..... | 32 | Routing | 70 |
| One-Touch Turn Signal | 33 | DRIVING..... | 72 |
| Wiper Operation | 33 | Before Driving..... | 72 |
| Adjusting the Seats..... | 35 | Maximum Load Limit | 73 |
| Driving Position Memory System... .. | 37 | Remote Engine Start* | 75 |
| Adjusting the Steering Wheel | 38 | Starting to Drive..... | 76 |
| Adjusting the Mirrors..... | 39 | Shifting | 77 |
| Customized Features..... | 40 | Braking..... | 81 |
| HomeLink® Garage Opener | 41 | Auto Idle Stop* | 83 |
| Climate Control System..... | 42 | Integrated Dynamics System (IDS) ... | 84 |
| Seat Heaters and Ventilation* | 43 | Vehicle Stability Assist (VSA®), aka Electronic Stability Control (ESC) System..... | 84 |

*if equipped

VISUAL INDEX

Quickly locate items in the vehicle's interior.

Steering Wheel and Nearby Controls

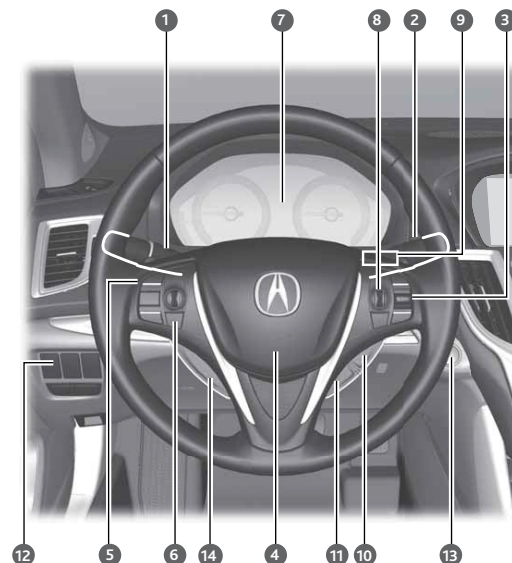

- 1 Lights/turn signals p. 32, p. 33
- 2 Wipers/washers p. 33
- 3 Cruise control/Adaptive Cruise Control with Low Speed Follow* buttons p. 85, p. 86
- 4 Horn
- 5 Voice recognition/*Bluetooth*® HandsFreeLink® buttons p. 55
- 6 Audio controls p. 45
- 7 Instrument panel p. 22
Multi-information display p. 26
- 8 Right selector wheel
TRIP button p. 26
- 9 Paddle shifters p. 78, p. 80
- 10 Advanced Cruise Control (ACC) Distance button* p. 86
- 11 Lane Keeping Assist System (LKAS) button* p. 90
- 12 Trunk release button p. 28
Fuel fill door button p. 97
Vehicle Stability Assist (VSA®) OFF button p. 84
Lane Departure Warning (LDW)*/
Road Departure Mitigation (RDM) button* p. 89, p. 92
Parking sensor button* p. 94
Collision Mitigation Braking System™ (CMBS™) OFF button* p. 91
Headlight washer button* p. 34
Heated windshield button* p. 34
- 13 ENGINE START/STOP button p. 76
- 14 Heated steering wheel* p. 38

| | | | |
|--|-----|---|-----|
| Cruise Control | 85 | Changing a Flat Tire | 105 |
| Adaptive Cruise Control (ACC) with Low Speed Follow (LSF)* | 86 | Fuse Locations | 108 |
| Forward Collision Warning (FCW) with Pedestrian Detection* | 88 | MAINTENANCE..... | 111 |
| Lane Departure Warning (LDW)* | 89 | Safety Precautions..... | 111 |
| Lane Keeping Assist System (LKAS)* | 90 | Maintenance Minder™ | 112 |
| Collision Mitigation Braking System™ (CMBS™)* | 91 | Under the Hood..... | 114 |
| Road Departure Mitigation (RDM) System* | 92 | Engine Oil | 116 |
| Blind Spot Information (BSI) System* | 93 | Engine Coolant | 118 |
| Parking Sensor System* | 94 | Window Washer Fluid | 119 |
| Super Handling-All Wheel Drive (AWD)* | 94 | Checking the Battery..... | 119 |
| Multi-View Rear Camera..... | 95 | Changing Wiper Blades | 120 |
| Rear Cross Traffic Monitor* | 96 | Tire Information | 121 |
| Refueling | 97 | Tire Labeling..... | 124 |
| HANDLING THE UNEXPECTED ... | 98 | DOT Tire Quality Grading | 125 |
| Keyless Access Remote Battery Strength..... | 98 | Tire Pressure Monitoring System (TPMS) - Required Federal Explanation | 127 |
| Shift Lever Does Not Move* | 98 | Testing of Readiness Codes | 128 |
| Jump Starting..... | 99 | SPECIFICATIONS | 129 |
| Overheating..... | 101 | CLIENT INFORMATION | 131 |
| Emergency Engine Stop..... | 102 | Frequently Asked Questions/ Troubleshooting | 131 |
| Emergency Towing | 102 | Contact Us | 132 |
| Tire Pressure Monitoring System (TPMS) | 103 | Acura Total Luxury Care Roadside Assistance | 133 |
| Tire Repair Kit* | 104 | Warranty Coverages..... | 133 |
| | | VOICE COMMAND INDEX | 134 |
| | | INDEX | 140 |

*if equipped

*if equipped

Dashboard and Ceiling Controls

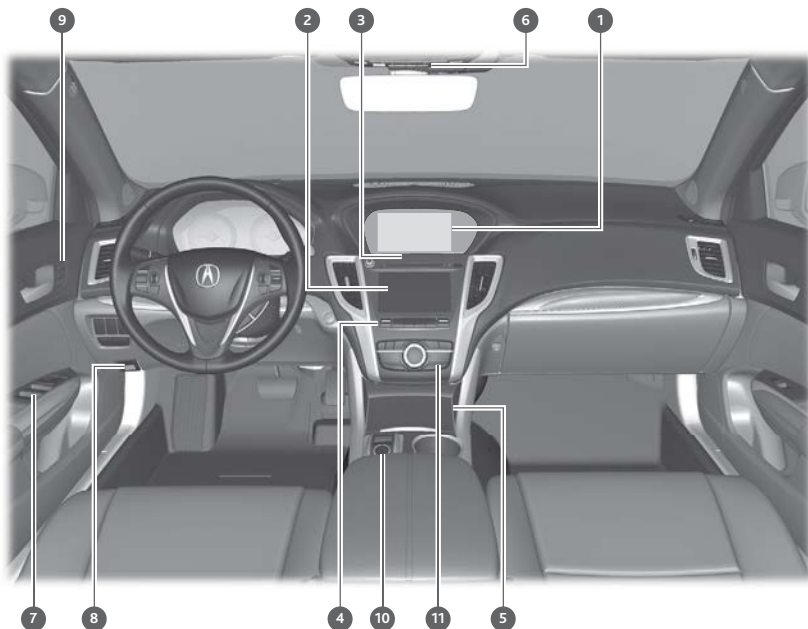

- 1 Color information display
- 2 On-Demand Multi-Use Display p. 46
- 3 Hazard warning button
- 4 Climate control buttons p. 42
- 5 USB adapter cable p. 44
- 6 Moonroof switch p. 31
Map lights p. 32
AcuraLink® buttons p. 63, p. 64
- 7 Power window switches p. 30
Door lock switches p. 29
Door mirror controls p. 39
- 8 Hood release handle p. 115116
- 9 Driving Position Memory System (DPMS) buttons p. 37
- 10 Integrated Dynamics System (IDS) button p. 84
Electric parking brake p. 81
Electronic gear selector* p. 79
Shift lever* p. 77
Brake hold button* p. 82
Auto idle stop button* p. 83
- 11 Audio/phone/navigation* buttons p. 46, p. 55, p. 65

**if equipped*

SAFETY INFORMATION

Your safety—and the safety of others—is very important, and operating this vehicle safely is an important responsibility. While we strive to help you make informed decisions about safety, it is not practical or possible to warn you about all the hazards associated with operating or maintaining your vehicle. Therefore, you must use your own good judgment.

Important Safety Information

This guide explains many of your vehicle's safety features and how to use them. Please read this information carefully. Following the instructions below will also help to keep you and your passengers safe.

■ Important Safety Precautions

- Always wear your seat belt.
- Secure all children in the proper restraint system.
- Be aware of airbag hazards.
- Don't drink and drive.
- Pay appropriate attention to the task of driving safely.
- Control your speed.
- Keep your vehicle in safe condition.

Engaging in cell phone conversation or other activities that keep you from paying close attention to the road, other vehicles, and pedestrians could lead to a crash. Remember, situations can change quickly, and only you can decide when it is safe to divert some attention away from driving.

■ Safety Messages

When you see the following messages throughout this guide, pay close attention.

- ⚠ DANGER** You **WILL** be **KILLED** or **SERIOUSLY HURT** if you don't follow instructions.
- ⚠ WARNING** You **CAN** be **KILLED** or **SERIOUSLY HURT** if you don't follow instructions.
- ⚠ CAUTION** You **CAN** be **HURT** if you don't follow instructions.
- NOTICE** This information is intended to help you avoid damage to your vehicle, other property, or the environment.

■ Carbon Monoxide Gas

The engine exhaust from this vehicle contains carbon monoxide, a colorless, odorless, and highly toxic gas. As long as you properly maintain your vehicle and follow the instructions set forth below, you will not accumulate dangerous levels of carbon monoxide gas in the vehicle interior.

Have the exhaust system inspected for leaks whenever:

- The exhaust system is making an unusual noise.
- The exhaust system may have been damaged.
- The vehicle is raised for an oil change.

When you operate a vehicle with the trunk open, airflow can pull exhaust gas into the interior and create a hazardous condition. If you must drive with the trunk open, open all the windows and set the climate control system as shown below.

1. Select the fresh air mode.
2. Select the  mode.
3. Set the fan speed to high.
4. Set the temperature control to a comfortable setting.

Adjust the climate control system in the same manner if you sit in your parked vehicle with the engine running.

WARNING

Carbon monoxide gas is toxic. Breathing it can cause unconsciousness and even kill you.

Avoid any enclosed areas or activities that expose you to carbon monoxide.

An enclosed area such as a garage can quickly fill up with carbon monoxide gas. Do not run the engine with the garage door closed. Even when the garage door is open, drive out of the garage immediately after starting the engine.

Seat Belts

A seat belt is your best protection in all types of collisions. Airbags are designed to supplement seat belts, not replace them. So even though your vehicle is equipped with airbags, make sure you and your passengers always wear your seat belts and wear them properly.

■ Lap/Shoulder Seat Belts

All five seating positions are equipped with lap/shoulder seat belts with emergency locking retractors. In normal driving, the retractor lets you move freely while keeping some tension on the belt. During a collision or sudden stop, the retractor locks to restrain your body. The front passenger's and rear seat belts also have a lockable retractor for use with child seats.

The front seats are equipped with automatic seat belt tensioners to enhance safety. The tensioners automatically tighten the front seat belts during a moderate-to-severe front collision, sometimes even if the collision is not severe enough to inflate the front airbags or the driver's knee airbag.

■ Proper Use of Seat Belts

Follow these guidelines for proper use:

- All occupants should sit upright, well back in the seat, and remain in that position for the duration of the trip. Slouching and leaning reduces the effectiveness of the belt and can increase the chance of serious injury in a crash.
- Never place the shoulder part of a lap/shoulder seat belt under your arm or behind your back. This could cause very serious injuries in a crash.
- Two people should never use the same seat belt. If they do, they could be very seriously injured in a crash.
- Do not put any accessories on the seat belts. Devices intended to improve comfort or reposition the shoulder part of a seat belt can reduce the protective capability and increase the chance of serious injury in a crash.
- No one should sit in a seat with an inoperative seat belt or one that does not appear to be working correctly. Using a seat belt that is not working properly may not protect the occupant in a crash. Have a dealer check the belt as soon as possible.

WARNING

Not wearing a seat belt properly increases the chance of a serious injury or death in a crash, even though your vehicle has airbags.

Be sure you and your passengers always wear seat belts and wear them properly.

■ Seat Belt Inspection

Regularly check the condition of your seat belts as follows:

- Pull each belt out fully, and look for frays, cuts, burns, and wear.
- Check that the latches work smoothly and the belts retract easily. If a belt does not retract easily, cleaning the belt may correct the problem. Only use a mild soap and warm water. Do not use bleach or cleaning solvents. Make sure the belt is completely dry before allowing it to retract.

Any belt that is not in good condition or working properly will not provide proper protection and should be replaced as soon as possible.

A belt that has been worn during a crash may not provide the same level of protection in a subsequent crash. Have your seat belts inspected by a dealer after any collision.

⚠️ WARNING

Not checking or maintaining seat belts can result in serious injury or death if the seat belts do not work properly when needed.

Check your seat belts regularly and have any problem corrected as soon as possible.

■ Fastening a Seat Belt

Adjust your seat to the proper position (see page 35), and then follow the below steps.

1. Pull the seat belt out slowly.
2. Insert the latch plate into the buckle, then tug on the belt to make sure the buckle is secure. Make sure that the belt is not twisted or caught on anything. On models with CMBS™, the front seat belts retract automatically.
3. Position the lap part of the belt as low as possible across your hips, then pull up on the shoulder part of the belt so the lap part fits snugly. This lets your strong pelvic bones take the force of a crash and reduces the chance of internal injuries.
4. If necessary, pull up on the belt again to remove any slack, then make sure that the belt rests across the center of your chest and over your shoulder. This spreads the forces of a crash over the strongest bones in your upper body.
5. To release the belt, push the red PRESS button then guide the belt by hand until it has retracted completely.

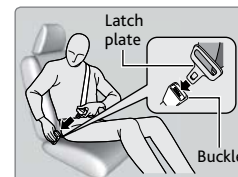

⚠️ WARNING

Improperly positioning the seat belts can cause serious injury or death in a crash.

Make sure all seat belts are properly positioned before driving.

■ Adjusting the Shoulder Anchor

The front seats have adjustable shoulder anchors to accommodate taller and shorter occupants.

1. Move the anchor up and down while holding the release button.
2. Position the anchor so that the belt rests across the center of your chest and over your shoulder.

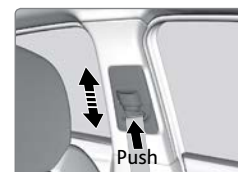

Airbags

Your vehicle is equipped with several types of airbags: front airbags, driver's knee airbag, side airbags, and side curtain airbags.

■ Front Airbags (SRS)

The front SRS airbags inflate in a moderate-to-severe frontal collision to help protect the head and chest of the driver and/or front passenger. They are housed in the center of the steering wheel for the driver, and in the dashboard for the front passenger. Both airbags are marked **SRS AIRBAG**.

SRS (Supplemental Restraint System) indicates that the airbags are designed to supplement seat belts, not replace them. Seat belts are the occupant's primary restraint system.

■ Driver's Knee Airbag

The driver's knee SRS airbag inflates with the driver's front airbag in a moderate-to-severe frontal collision to help keep the driver in the proper position and to help maximize the benefit provided by the vehicle's other safety features.

■ Advanced Airbags

Your front airbags have advanced features to help reduce the likelihood of airbag-related injuries to smaller occupants.

The driver's advanced front airbag system includes a seat position sensor. If the seat is too far forward, the airbag inflates with less force, regardless of the severity of the impact.

If there is a problem with the driver's seat position sensor, the SRS indicator will come on and the airbag will inflate with full (normal) force, regardless of the driver's seating position.

The passenger's advanced front airbag system has weight sensors. Although Acura recommends against carrying an infant or small child in front, if the sensors detect the weight of a child (up to 65 lbs or 29 kg), the system will automatically turn off the passenger's front airbag.

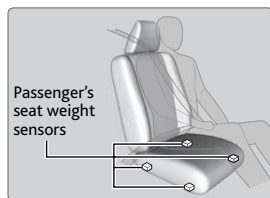
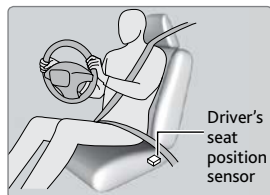

For both advanced front airbags to work properly:

- Do not spill any liquid on or under the seats.
- Do not put any object under the passenger's seat.
- Make sure any objects are positioned properly on the floor. Improperly positioned objects can interfere with the advanced airbag sensors.
- All occupants should sit upright and wear their seat belts properly.
- Do not place any cover over any part of the passenger side dashboard.

■ Side Airbags

The side airbags help protect the upper torso and pelvis of the driver or a front passenger during a moderate-to-severe side impact. They are housed in the outside edge of the driver's and front passenger's seat-backs. Both are marked **SIDE AIRBAG**.

■ Side Curtain Airbags

Side curtain airbags help protect the head and torso of the driver and passengers in outer seating positions during a moderate-to-severe side impact. The side curtain airbags equipped in this vehicle are also designed to help reduce the likelihood of partial and complete ejection of vehicle occupants through side windows in crashes, particularly rollover crashes.

The side curtain airbags are located in the ceiling above the side windows on both sides of the vehicle.

The side curtain airbags are designed to deploy in a rollover or moderate-to-severe side impact. If the SRS control unit senses that your vehicle is about to roll over, it immediately deploys both side curtain airbags and activates both front seat belt tensioners. If the impact is on the passenger's side, the passenger's side curtain airbag will inflate even if there are no occupants on that side of the vehicle.

To get the best protection from the side curtain airbags, occupants should wear their seat belts properly and sit upright and well back in their seats.

Do not attach any objects to the side windows or roof pillars, as they can interfere with the proper operation of the side curtain airbags.

When side curtain airbags deploy in a frontal collision

One or both side curtain airbags may inflate in a moderate-to-severe angled frontal collision. In this case, the side curtain airbags will deploy slightly after the front airbags.

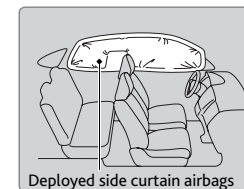
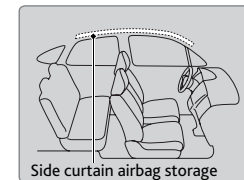

■ Important Facts About Your Airbags

Always wear your seat belt properly, and sit upright and as far back from the steering wheel as possible while allowing full control of the vehicle. A front passenger should move their seat as far back from the dashboard as possible.

Do not place hard or sharp objects between yourself and a front airbag.

Carrying hard or sharp objects on your lap, or driving with a pipe or other sharp object in your mouth, can result in injuries if your front airbag inflates.

Do not attach or place objects on the front and driver's knee airbag covers.

Objects on the covers marked **SRS AIRBAG** could interfere with the proper operation of the airbags or be propelled inside the vehicle and hurt someone if the airbags inflate.

Do not attach accessories on or near the side airbags. They can interfere with the proper operation of the airbags, or hurt someone if an airbag inflates.

Do not attach any objects to the side windows or roof pillars. They can interfere with the proper operation of the side curtain airbags.

Do not cover or replace the front seat-back covers. This can prevent your side airbags from properly deploying during a side impact.

⚠ WARNING

An open glove box can cause serious injury to your passenger in a crash, even if the passenger is wearing the seat belt.

Always keep the glove box closed while driving.

■ Airbag System Indicators

If a problem occurs in the airbag system, the SRS indicator will come on and a message appears on the multi-information display.

SRS (Supplemental Restraint System) Indicator

If the indicator comes on at any other time besides vehicle start-up, or does not come on at all, have the system checked by a dealer as soon as possible. If you don't, your airbags and seat belt tensioners may not work properly when they are needed.

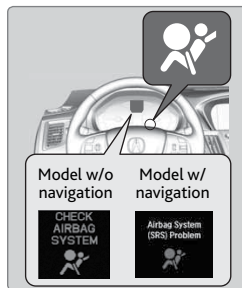

⚠ WARNING

Ignoring the SRS indicator can result in serious injury or death if the airbag systems or tensioners do not work properly.

Have your vehicle checked by a dealer as soon as possible if the SRS indicator alerts you to a possible problem.

Passenger Airbag Off Indicator

The indicator comes on to alert you that the front passenger's front airbag has been turned off. This occurs when the front passenger's weight sensors detect 65 lbs (29 kg) or less, the weight of an infant or small child, on the seat.

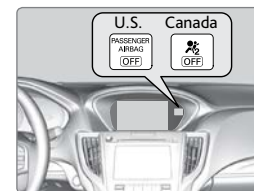

Infants and small children should always ride properly restrained in a back seat.

Objects placed on the seat can also cause the indicator to come on.

If the front passenger's seat is empty, the passenger's front airbag will not deploy and the indicator will not come on.

If the indicator comes on with no occupant or objects in the front passenger's seat, something may be interfering with the weight sensors, such as:

- An object hanging on the seat or in the seat-back pocket.
- A child seat or other object pressing against the rear of the seat-back.
- A rear passenger pushing or pulling on the back of the front passenger's seat.
- The front seat or seat-back is forced against an object on the seat or floor behind it.
- An object placed under the front passenger's seat.

If none of these conditions exist, have your vehicle checked by a dealer as soon as possible.

The passenger airbag off indicator may go on and off repeatedly if the total weight on the seat is near the airbag cutoff threshold.

Airbag System Components

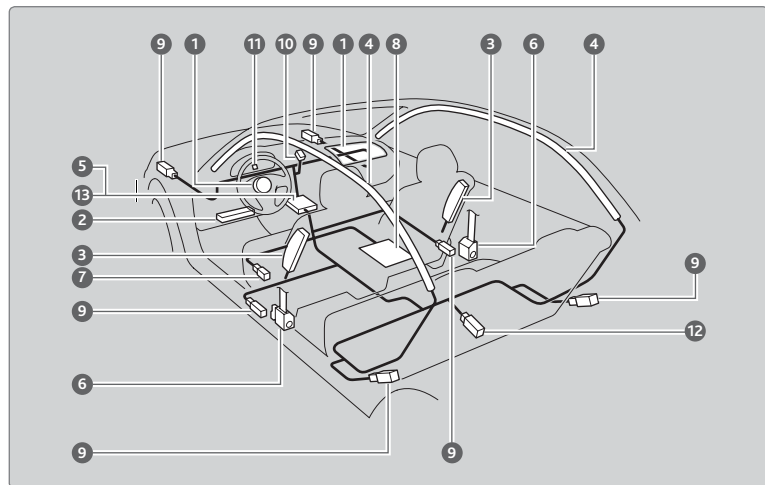

- 1 Two SRS (Supplemental Restraint System) front airbags. The driver's airbag is stored in the center of the steering wheel; the front passenger's airbag is stored in the dashboard. Both are marked **SRS AIRBAG**.
- 2 Driver's knee airbag. The knee airbag is stored under the steering column. It is marked **SRS AIRBAG**.
- 3 Two side airbags, one for the driver and one for the front passenger. The airbags are stored in the outer edges of the seat-backs. Both are marked **SIDE AIRBAG**.
- 4 Two side curtain airbags, one for each side of the vehicle. The airbags are stored in the ceiling, above the side windows. The front and rear pillars are marked **SIDE CURTAIN AIRBAG**.
- 5 An electronic control unit that continually monitors and can record information about the sensors, the airbag activators, the seat belt tensioners, and driver and front passenger seat belt use when the vehicle is on.
- 6 Automatic front seat belt tensioners. The driver's and front passenger's seat belts incorporate sensors that detect whether or not they are fastened.
On models with CMBS™, the front seat belt tensioners also include the e-pretensioners.
- 7 A driver's seat position sensor. If the seat is too far forward, the airbag will inflate with less force.
- 8 Weight sensors in the front passenger's seat. The front passenger's airbag will be turned off if the weight on the seat is 65 lbs (29 kg) or less (the weight of an infant or small child).

- 9 Impact sensors that can detect a moderate-to-severe front or side impact.
- 10 An indicator on the dashboard that alerts you that the front passenger's front airbag has been turned off.
- 11 An indicator on the instrument panel that alerts you to a possible problem with the airbag system or seat belt tensioners.
- 12 Safing sensor
- 13 A rollover sensor that detects whether the vehicle is about to roll over.

Airbag Care

You do not need to, and should not, perform any maintenance on or replace any airbag system components yourself. However, you should have your vehicle inspected by a dealer in the following situations:

When the airbags have deployed

If an airbag has inflated, the control unit and other related parts must be replaced. Similarly, once an automatic seat belt tensioner has been activated, it must be replaced.

When the vehicle has been in a moderate-to-severe collision

Even if the airbags did not inflate, have your dealer inspect the following: the driver's seat position sensor, weight sensors in the passenger's seat, front seat belt tensioners, and each seat belt that was worn during the crash.

Do not remove or modify a front seat without first consulting a dealer

This would likely disable the driver's seat position sensor or the weight sensors in the passenger's seat. If it is necessary to remove or modify a front seat to accommodate a person with disabilities, contact an Acura dealer. For U.S. vehicles, call Acura Client Relations at (800) 382-2238. For Canadian vehicles, call Acura Client Services at (888) 922-8729.

Child Safety

Each year, many children are injured or killed in vehicle crashes because they are either unrestrained or not properly restrained. In fact, vehicle collisions are the number one cause of death of children ages 12 and under.

The National Highway Traffic Safety Administration and Transport Canada recommend that all children ages 12 and under be properly restrained in a rear seat. Some states or provinces/territories have laws restricting where children may ride.

To reduce the number of child deaths and injuries, every state, Canadian province, and territory requires that infants and children be properly restrained when they ride in a vehicle.

■ Protecting Child Passengers – Important Considerations

- An inflating front or side airbag can injure or kill a child sitting in the front seat.
- A child in the front seat is more likely to interfere with the driver's ability to safely control the vehicle.
- Statistics show that children of all sizes and ages are safer when they are properly restrained in a rear seat.
- Any child who is too small to wear a seat belt correctly must be restrained in an approved child seat that is properly secured to the vehicle using either the lap belt portion of the lap/shoulder belt or the lower anchors of the LATCH system.
- Never hold a child on your lap because it is impossible to protect them in the event of a collision.
- Never put a seat belt over yourself and a child. During a crash, the belt would likely press deep into the child and cause serious or fatal injuries.
- Never let two children use the same seat belt. Both children could be very seriously injured in a crash.
- Do not allow children to operate the doors, windows, or seat adjustments.
- Do not leave children in the vehicle unattended, especially in hot weather when the inside of the vehicle can get hot enough to kill them. They could also activate vehicle controls, causing it to move unexpectedly.

⚠️ WARNING

Children who are unrestrained or improperly restrained can be seriously injured or killed in a crash.

Any child too small for a seat belt should be properly restrained in a child seat. A larger child should be properly restrained with a seat belt, using a booster seat if necessary.

⚠️ WARNING

Allowing a child to play with a seat belt or wrap one around their neck can result in serious injury or death.

Instruct children not to play with any seat belt and make sure any unused seat belt a child can reach is buckled, fully retracted, and locked.

■ Protecting Infants

An infant must be properly restrained in a rear-facing, reclining child seat until the infant reaches the seat maker's weight or height limit for the seat, and the infant is at least one year old. Many experts recommend use of a rear-facing seat for a child up to two years old if the child's height and weight are appropriate for a rear-facing seat.

Child seats must be placed and secured in a rear seating position. Rear-facing child seats should never be installed in a forward-facing position.

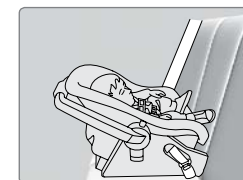

When properly installed, a rear-facing child seat may prevent the driver or a front passenger from moving their seat all the way back, or from locking their seat-back in the desired position. If this occurs, we recommend that you install the child seat directly behind the front passenger's seat, move the seat as far forward as needed, and leave it unoccupied. Or, you may wish to get a smaller rear-facing child seat.

⚠️ WARNING

Placing a rear-facing child seat in the front seat can result in serious injury or death during a crash.

Always place a rear-facing child seat in the rear seat, not the front.

■ Protecting Smaller Children

If a child is at least one year old and within the weight range indicated by the child seat manufacturer, the child should be properly restrained in a firmly secured forward-facing child seat.

We strongly recommend placing a forward-facing child seat in a rear seating position.

Placing a forward-facing child seat in the front seat can be hazardous, even with advanced front airbags that automatically turn the passenger's front airbag off. A rear seat is the safest place for a child.



⚠ WARNING

Placing a forward-facing child seat in the front seat can result in serious injury or death if the front airbag inflates.

If you must place a forward-facing child seat in front, move the vehicle seat as far back as possible, and properly restrain the child.

■ Selecting a Child Seat

Most child seats are LATCH-compatible (Lower Anchors and Tethers for Children). Some have a rigid-type connector, while others have a flexible-type connector. Both are equally easy to use. Some existing and previously owned child seats can only be installed using the seat belt. Whichever type you choose, follow the child seat manufacturer's use and care instructions as well as the instructions in this guide. Proper installation is key to maximizing your child's safety.

In seating positions and vehicles not equipped with LATCH, a LATCH compatible child seat can be installed using the seat belt and a top tether for added security. This is because all child seats are required to be designed so that they can be secured with a lap belt or the lap part of a lap/shoulder belt. In addition, the child seat manufacturer may advise that a seat belt be used to attach a LATCH-compatible seat once a child reaches a specified weight. Please read the child seat owner's manual for proper installation instructions.

Important considerations when selecting a child seat

Make sure the child seat meets the following three requirements:

- The child seat is the correct type and size for the child.
- The child seat is the correct type for the seating position.
- The child seat is compliant with Federal Motor Vehicle Safety Standard 213 or Canadian Motor Vehicle Safety Standard 213.

■ Installing a LATCH-Compatible Child Seat

A LATCH-compatible child seat can be installed in any of the rear seats. A child seat is attached to the lower anchors in the outer seats with either the rigid or flexible type of connectors. The center seat only has an upper tether anchorage point.

1. Locate the lower anchors under the marks.
2. Place the child seat on the vehicle seat, then attach the child seat to the lower anchors according to the instructions that came with the child seat. Make sure that the lower anchors are not obstructed by the seat belt or any other object.
3. Open the tether anchor cover behind the head restraint.
4. Raise the head restraint to its highest position, then route the tether strap between the head restraint legs, and secure the tether strap hook onto the anchor.
5. Tighten the tether strap as instructed by the child seat maker.
6. Make sure the child seat is firmly secured by rocking it forward and back and side to side; little movement should be felt.
7. Make sure any unused seat belt that a child can reach is buckled, the lockable retractor is activated, and the belt is fully retracted and locked.

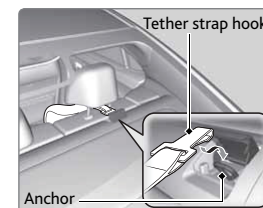
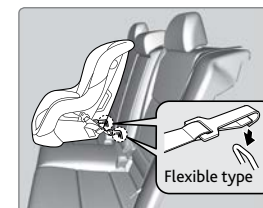
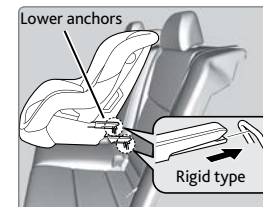
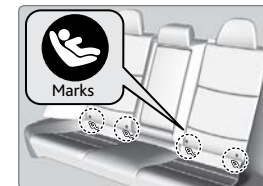

■ Installing a Child Seat with a Lap/Shoulder Seat Belt

1. Place the child seat on the vehicle seat.
2. Route the seat belt through the child seat according to the seat maker's instructions, and insert the latch plate into the buckle. Insert the latch plate fully until it clicks.
3. Slowly pull the shoulder part of the belt all the way out until it stops. This activates the lockable retractor.
4. Let the seat belt completely wind up into the retractor, then try to pull it out to make sure the retractor is locked. If you are able to pull the shoulder belt out, the lockable retractor is not activated. Pull the seat belt all the way out, and repeat steps 3 – 4.
5. Grab the shoulder part of the seat belt near the buckle, and pull up to remove any slack from the lap part of the belt. When doing this, place your weight on the child seat and push it into the vehicle seat.
6. Make sure the child seat is firmly secured by rocking it forward and back and side to side; little movement should be felt.
7. Make sure any unused seat belt that a child can reach is buckled, the lockable retractor is activated, and the belt is fully retracted and locked.

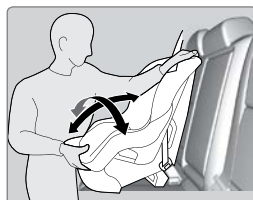
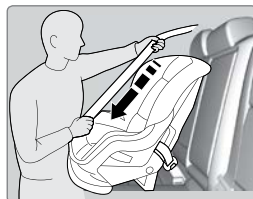
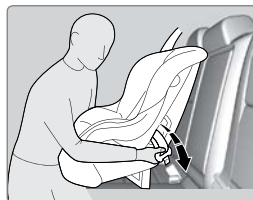

To deactivate a lockable retractor, release the buckle and allow the seat belt to wind up all the way.

■ Adding Security with a Tether

A tether anchorage point is provided behind each rear seating position. A child seat that is installed with a seat belt and comes with a tether can use the tether for additional security.

1. Locate the appropriate tether anchorage point and lift the cover.
2. Raise the head restraint to its highest position, then route the tether strap through the head restraint legs. Make sure the strap is not twisted.
3. Secure the tether strap hook onto the anchor.
4. Tighten the tether strap as instructed by the child seat manufacturer.

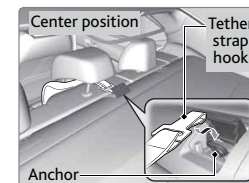
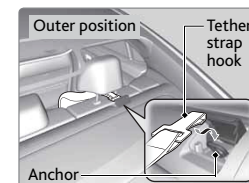
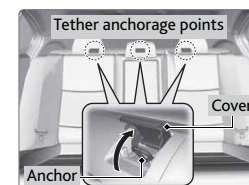

■ Protecting Larger Children

When a child is too big for a child seat, secure the child in a rear seat using the lap/shoulder seat belt.

Have the child sit upright and all the way back, then ensure the following:

- The child's knees bend comfortably over the edge of the seat.
- The shoulder belt crosses between the child's neck and arm.
- The lap part of the seat belt is as low as possible, touching the child's thighs.
- The child can stay seated for the whole trip.



If a lap/shoulder belt cannot be used properly, position the child in a booster seat in a rear seating position. For the child's safety, check that the child meets the booster seat manufacturer's recommendations.

Some U.S. states and Canadian provinces/territories require children to use a booster seat until they reach a given age or weight (e.g., 6 years or 60 lbs). Be sure to check current laws in the state or province/territory where you intend to drive.

⚠️ WARNING

Allowing a child age 12 or under to sit in the front can result in injury or death if the passenger's front airbag inflates.

If a larger child must ride in front, move the vehicle seat as far to the rear as possible, have the child sit up properly and wear the seat belt properly, using a booster seat if needed.

Safety Label Locations

Safety labels are in the locations shown. They warn you of potential hazards that can cause serious injury or death. Read these labels carefully.

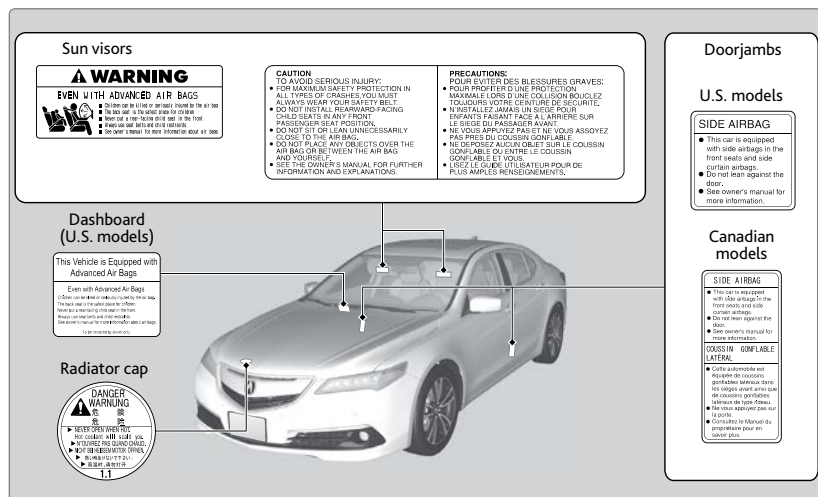

Reporting Safety Defects

In the U.S.

If you believe that your vehicle has a defect which could cause a crash or could cause injury or death, you should immediately inform the National Highway Traffic Safety Administration (NHTSA) in addition to notifying American Honda Motor Co., Inc.

If NHTSA receives similar complaints, it may open an investigation, and if it finds that a safety defect exists in a group of vehicles, it may order a recall and remedy campaign. However, NHTSA cannot become involved in individual problems between you, your dealer, or American Honda Motor Co., Inc.

To contact NHTSA, you may call the Vehicle Safety Hotline toll-free at 1-888-327-4236 (TTY: 1-800-424-9153); go to <http://www.safercar.gov>; or write to: Administrator, NHTSA, 1200 New Jersey Avenue, SE., Washington, DC 20590. You can also obtain other information about motor vehicle safety from <http://www.safercar.gov>.

In Canada

If you believe that your vehicle has a defect which could cause a crash or could cause injury or death, you should immediately inform Honda Canada, Inc., and you may also inform Transport Canada.

If Transport Canada receives similar complaints, it may open an investigation, and if it finds that a safety defect exists in a group of vehicles, it may lead to a recall and remedy campaign. However, Transport Canada cannot become involved in individual problems between you, your dealer, or Honda Canada, Inc.

To contact Transport Canada's Defect Investigations and Recalls Division, you may call 1-800-333-0510. For more information on reporting safety defects or about motor vehicle safety, go to <http://www.tc.gc.ca/roadsafety>.

INSTRUMENT PANEL

Learn about the indicators, gauges, and displays related to driving the vehicle.

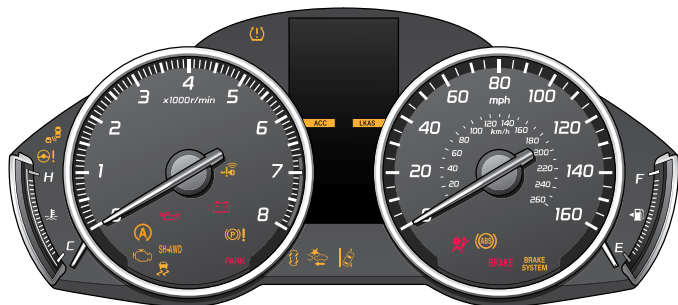

Indicators briefly appear with each engine start and then go out. Red and amber indicators are most critical. Blue and green indicators are used for general information.

Malfunction Indicators

These are the most critical indicators. If they come on and stay lit while driving or at any other time, there may be a problem. See your dealer if necessary.

BRAKE Brake system



- Brake fluid is low.
- There is a malfunction in the brake system.

Press the brake pedal lightly to check pedal pressure. If normal, check the brake fluid level when you stop. If abnormal, take immediate action. If necessary, downshift the transmission to slow the vehicle using engine braking. Have your vehicle repaired immediately.



Low oil pressure

Engine oil pressure is low. Stop in a safe place. Open the hood and check the oil level, and add oil if necessary (see page 117). If the indicator does not turn off, have your vehicle repaired immediately.



Malfunction indicator lamp (check engine light)

- The emissions control system may have a problem.
- (Blinks) A misfire in the engine's cylinders is detected. Stop in a safe place, and wait for the engine to cool down.



Charging system

The battery is not charging. Turn all electrical items off, but do not turn the vehicle off to prevent further battery discharge. Have your vehicle repaired immediately.



Precision All-Wheel Steer™ (P-AWS®)*

There is a problem with the system. Vehicle speed may be limited to 50 mph (80 km/h) or less.



ABS (Anti-lock Brake System)

There is a problem with the anti-lock brake system. Your vehicle still has normal braking ability, but no anti-lock function.



Supplemental Restraint System (SRS)

There is a problem with one of the airbag systems or seat belt tensioners*.



Electric Power Steering (EPS)

There is a problem with the electric power steering system. Stop in a safe place and restart the engine.



Tire Pressure Monitoring System (TPMS)

(Blinks and stays on) There is a problem with the tire pressure monitoring system, or a spare tire* is installed.



Keyless Access system

There is a problem with the keyless access system.



Vehicle Stability Assist® (VSA®) system

- There is a problem with the VSA system or hill start assist system.
- (Blinks) VSA is active.



Brake system

There is a problem with automatic brake hold, ACC*, CMBS*, or RDM*. Avoid high speeds and sudden braking. Your vehicle still has normal braking ability.



Blind Spot Information (BSI) system*

There is a problem with the BSI system or the sensor is blocked.



Adaptive Cruise Control (ACC) with Low Speed Follow*

There is a problem with the ACC system.



Lane Keeping Assist System (LKAS)*

There is a problem with the LKAS.



Forward Collision Warning (FCW) system*/Collision Mitigation Braking System™ (CMBS™)*

There is a problem with the system, the system is turned off, the temperature is too high, or the camera is blocked.



Lane Departure Warning (LDW)*/Road Departure Mitigation (RDM)* system

There is a problem with the system, the temperature is too high, or the camera is blocked.



Electric parking brake system

There is a problem with the electric parking brake system. Stop in a safe place and avoid using the parking brake.



Electric parking brake

(Blinks) There is a problem with the electric parking brake system.

*if equipped

A **Auto Idle Stop***
(Blinks) There is a problem with the auto idle stop system.

- SH-AWD** **Super Handling-All Wheel Drive™ (SH-AWD®)***
- There is a problem with the SH-AWD system. The engine drives only the front wheels.
 - (Blinks) The differential temperature is too high. Stop in a safe place, shift to Park (P), and idle until the indicator goes off.

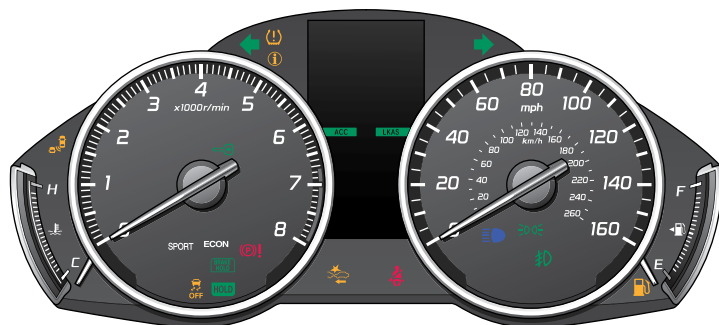

Condition Indicators

These indicators may require you to perform an action.

- P** **Electric parking brake**
Release the parking brake before driving. You will hear a beep if you drive with it not fully released.
- S** **Seat belt reminder**
Make sure seat belts are fastened for you and all passengers. The indicator blinks and beeps sound continuously if you or your front passenger has not fastened your seat belts when you begin driving. If the indicator remains on after seat belts are fastened, see your dealer.
- F** **Low fuel**
Refuel as soon as possible. If the indicator blinks, there is a problem with the fuel gauge. See your dealer.
- T** **Low tire pressure**
Stop in a safe place, check tire pressures, and inflate tire(s) if necessary.

i **System message**
When a condition or malfunction indicator comes on, a message also appears on the multi-information display. Check the display for more information.

🔑 **Immobilizer**
Your remote transmitter cannot be recognized by the vehicle. If the indicator blinks, you may not be able to start the engine. Turn the vehicle off, and then on again. If it continues to blink, there may be a problem with the system. See your dealer.

On/Off Indicators

These indicators remind you when an item is on or off.

- OFF** VSA off
- ACC** ACC* on
- CRUISE MAIN** CRUISE MAIN on
- LKAS** LKAS* on
- CRUISE CONTROL** CRUISE CONTROL on
- SPORT** SPORT mode on
- ↔** Turn signals/hazards on
- ECON** ECON mode on
- ☀** Exterior lights on
- BRAKE HOLD** Automatic brake hold on
- 🌫** Fog lights* on
- HOLD U.S. / CANADA** Automatic brake activated
- ☀** High beams on
- A** Auto idle stop* activated
- 👉👈** FCW*/CMBS™* off
- A** Auto idle stop* off
- 📶** BSI* off

*if equipped

*if equipped

TABLE OF CONTENTS

VISUAL INDEX

SAFETY INFORMATION

INSTRUMENT PANEL

VEHICLE CONTROLS

AUDIO AND CONNECTIVITY

BLUETOOTH® HANDSFREELINK®

ACURALINK®

NAVIGATION

DRIVING

HANDLING THE UNEXPECTED

MAINTENANCE

SPECIFICATIONS

CLIENT INFORMATION

VOICE COMMAND INDEX

INDEX

Multi-Information Display

Consists of several displays that provide you with useful information.

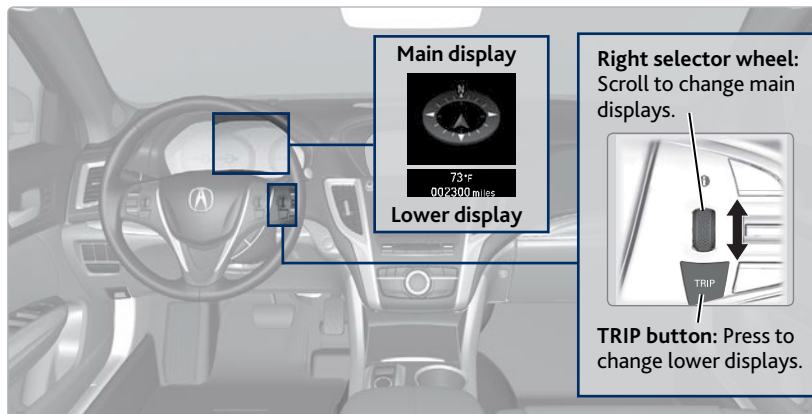

Main Displays

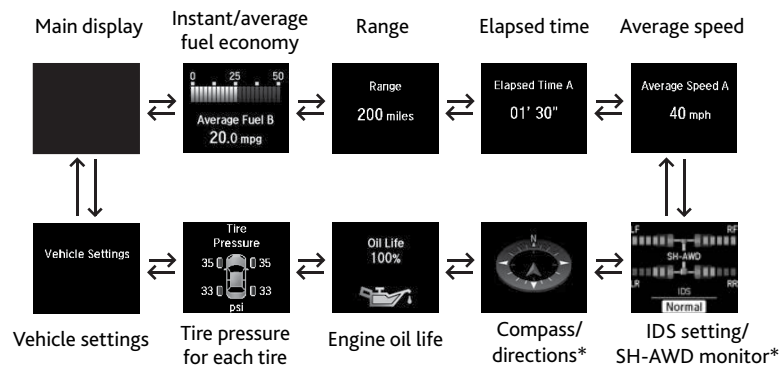

Lower Displays

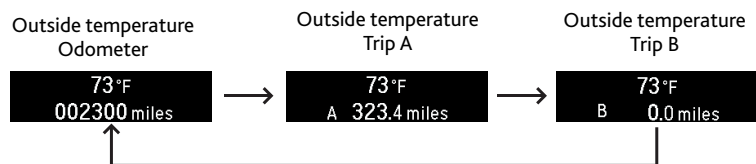

**if equipped*

VEHICLE CONTROLS

Learn about the various controls necessary for operating and driving the vehicle.

Using the Remote Transmitter

Lock or unlock the doors and trunk.

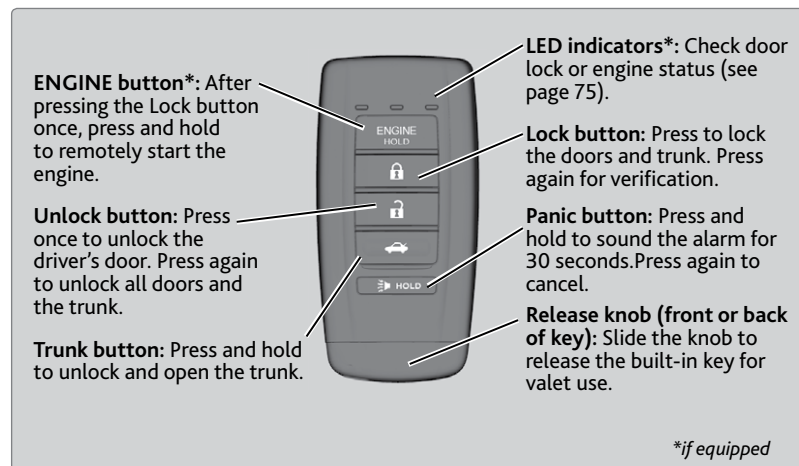

NOTICE

Leaving the remote transmitter in the vehicle can result in theft or accidental movement of the vehicle. Always take it with you whenever you leave the vehicle unattended.

Keyless Access System

When you carry the remote transmitter (for example, in a pocket or purse) and it is outside the vehicle and within range (about 32 inches or 80 cm), you can lock or unlock the doors and trunk without handling the transmitter.

■ Unlocking/Locking the Doors

To unlock: Grab either front door (or rear door*) handle when the vehicle is off.

The driver's seat slides rearward when the driver's door is opened to allow easy entry. The seat slides forward to the last driving position when the vehicle is turned on (see page 37).

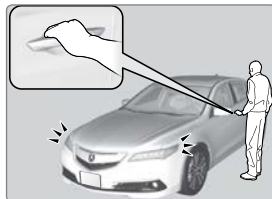

To lock: Press the door lock button on either front door (or rear door*) handle when the vehicle is off. If the remote transmitter is inside the vehicle, the doors will not lock.

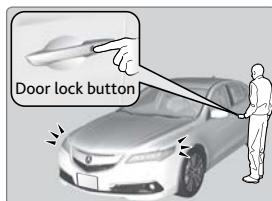

■ Opening the Trunk

Press the trunk release button under the trunk handle to unlock and open the trunk. The vehicle can be on or off.

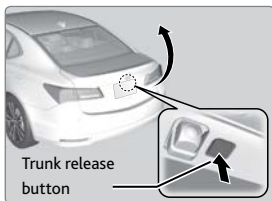

Door Operation from Inside the Vehicle

Use these methods to lock or unlock the doors.

■ Using the Lock Tab

To unlock: When you unlock either front door using the lock tab, the specific door (driver's or passenger's) unlocks.

To lock: When you lock the door using the lock tab on the driver's door, all the other doors and trunk lock at the same time. When you lock the door using the lock tab on the front passenger's door, only that door locks.

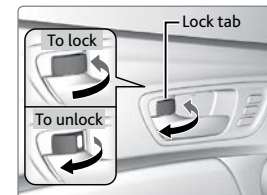

■ Using the Master Door Lock Switch

To unlock: Press the unlock side of the switch to unlock all doors and the trunk.

To lock: Press the lock side of the switch to lock all doors and the trunk.

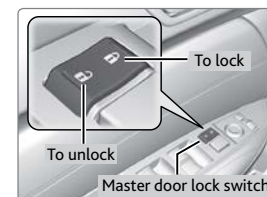

■ Using the Front Door Inner Handle

Pull the front door inner handle. The door unlocks and opens in one motion. Unlocking and opening the driver's door from the inner handle unlocks all other doors.

Do not pull a front door inner handle while the vehicle is moving.



■ Childproof Door Locks

The childproof door locks prevent the rear doors from being opened from the inside regardless of the position of the lock tab.

Slide the lever in the rear door to the lock position, and close the door.

Open the door using the outer door handle.

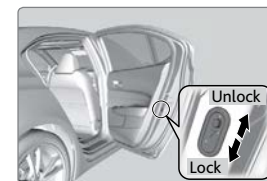

■ Using the Trunk Release Button

Press the trunk release button on the dashboard next to the steering column when all doors are unlocked to open the trunk.

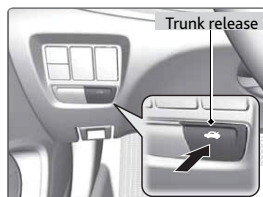

Power Window Operation

The power windows can be opened and closed when the vehicle is on by using the switches on the doors. The switches on the driver's side can be used to open and close all the windows.

■ Automatic Operation

To open: Push the switch down firmly.

To close: Pull the switch up firmly.

The window opens or closes completely. To stop the window at any time, push or pull the switch again briefly.

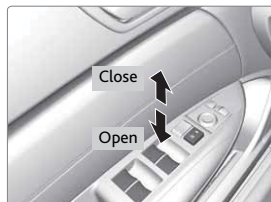

■ Manual Operation

To open: Push the switch down lightly.

To close: Pull the switch up lightly.

Release the switch when the windows reach the desired position.

■ Power Window Lock

Push in the power window lock button so only the driver's window can be operated.



⚠ WARNING

Closing a power window on someone's hands or fingers can cause serious injury.

Make sure your passengers are away from the windows before closing them.

Power Moonroof Operation

The moonroof can be opened and closed when the vehicle is on by using the switch on the ceiling.

■ Automatic Operation

To open: Push the switch back firmly to the second detent, then release.

To close: Push the switch forward firmly to the second detent, then release.

The moonroof opens or closes completely. To stop the moonroof at any time, push the switch briefly.

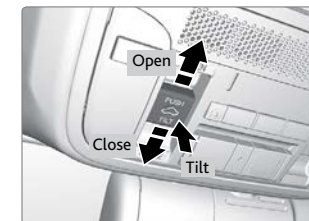

■ Manual Operation

To open: Push and hold the switch back to the first detent until the desired position is reached.

To close: Push and hold the switch forward to the first detent until the desired position is reached.

■ Moonroof Tilt

To tilt: Push the center of the switch.

To close: Push the switch forward firmly, then release.

NOTICE

Opening the moonroof in below freezing temperatures or when it is covered with snow or ice can damage the moonroof panel or motor.

⚠ WARNING

Closing the moonroof on someone's hands or fingers can cause serious injury.

Make sure your passengers are away from the moonroof before closing it.

Interior and Exterior Lights

Operate interior and exterior lights when the vehicle is on or off.

Exterior Lights

Rotate the switches on the lever to operate the exterior lights. Push the lever forward to turn on the high beams. Return the lever to its original position for low beams.

- OFF** All exterior lights are off.
- AUTO** Turn on the automatic lighting feature. Headlights turn on or off depending on ambient brightness when the vehicle is on. Headlights automatically come on after the wipers are engaged for a certain time.

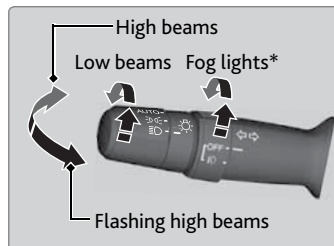

- Turn on exterior lights except headlights.
- Turn on all exterior lights including headlights.
- Turn fog lights on or off.*

Brightness Control

Adjust instrument panel brightness when the vehicle is on.

To brighten: Press the + button.

To dim: Press the - button.

A beep sounds when the brightness reaches minimum or maximum.

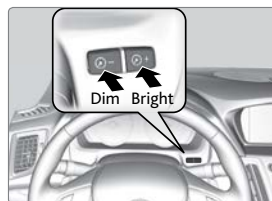

Interior Lights

Lights are located on the ceiling.

ON position: Interior lights remain on.

Door-activated position: Interior lights come on when any of the doors are opened, the driver's door is unlocked, or the vehicle is turned off.

OFF position: Interior lights remain off.

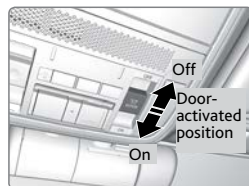

*if equipped

One-Touch Turn Signal

Use this quick and convenient method to signal a lane change.

- Lightly push the turn signal lever up or down for a three-blink sequence.
- For a continuous signal, push the lever up or down until it locks into place.

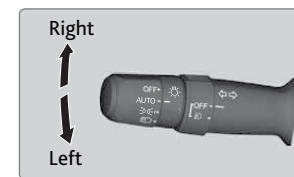

Wiper Operation

The windshield wipers and washers can be used when the vehicle is on. Move the wiper lever up or down to the desired position.

Headlight-Wiper Integration

When the headlights are in the AUTO position, they automatically turn on when the front wipers operate several times within a certain interval. The headlights turn off shortly after the wipers are turned off, or if there is enough ambient light.

Intermittent Wipers*

When you move the lever to the INT position, the wipers operate based on the delay adjustment.

Adjust the wiper delay using the intermittent time adjustment ring.

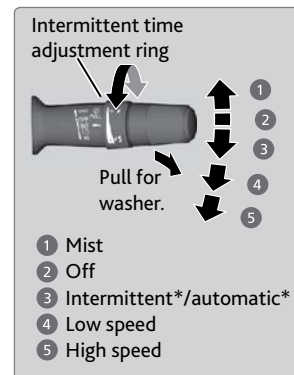

Automatic Rain-Sensing Wipers*

When you move the lever to the AUTO position while driving in rainy weather, the wipers operate based on the amount of detected rainfall.

Adjust the rainfall sensor sensitivity using the intermittent time adjustment ring.

NOTICE

Always ensure the wiper lever is in the OFF position before entering a car wash to prevent severe damage to the windshield wiper system.

*if equipped

NOTICE

Do not use the wipers when the windshield is dry. The windshield will get scratched, or the rubber blades will get damaged.

In cold weather, the blades may freeze to the windshield, becoming stuck. Operating the wipers in this condition may damage the wipers. Use the defroster to warm the windshield, or manually clear the windshield of ice and snow before turning on the wipers.

Headlight Washers*

Canadian models

Turn the headlights on. Press the headlight washer button to operate the washers.

The headlight washers also operate when you first turn on the windshield wipers.

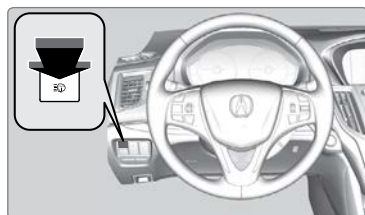

Heated Windshield Button*

Canadian models

Turn the vehicle on. Press the heated windshield button to de-ice the windshield.

The heated windshield may automatically activate when the outside temperature is below 4°C, and deactivate when the temperature reaches 6°C.

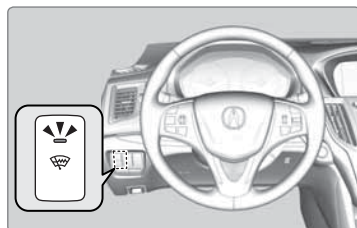

*if equipped

Adjusting the Seats

Make seat adjustments before driving to ensure the best comfort and safety.

Adjusting the Front Seats

Adjust the driver's seat as far back as possible while allowing you to maintain full control of the vehicle. You should be able to sit upright and well back in the seat, adequately press the pedals without leaning forward, and grip the steering wheel comfortably. The passenger's seat should be adjusted so that it is as far back from the front airbag in the dashboard as possible.

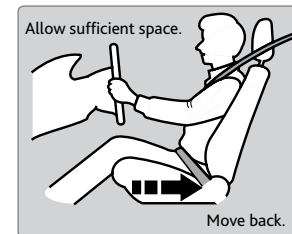

The National Highway Traffic Safety Administration and Transport Canada recommend that drivers allow at least 10 inches (25 cm) between the center of the steering wheel and the chest.

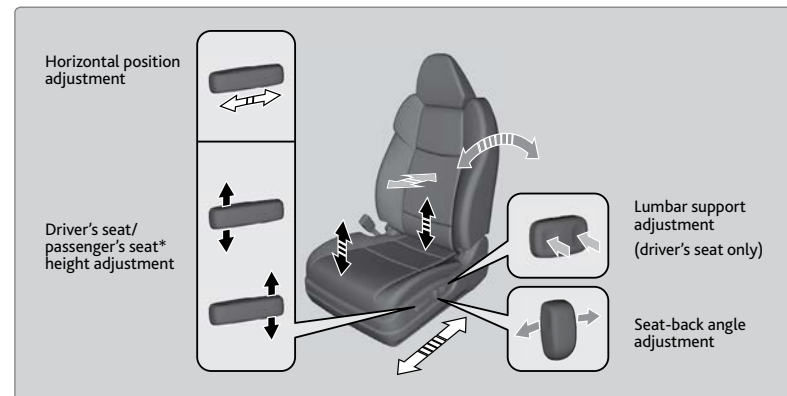

WARNING

Sitting too close to a front airbag can result in serious injury or death if the front airbags inflate.

Always sit as far back from the front airbags as possible while maintaining control of the vehicle.

WARNING

Reclining the seat-back too far can result in serious injury or death in a crash. Adjust the seat-back to an upright position, and sit well back in the seat.

*if equipped

⚠️WARNING

Sitting improperly or out of position can result in serious injury or death in a crash.

Always sit upright, well back in the seat, with your feet on the floor.

■ Adjusting the Head Restraints

Your vehicle is equipped with head restraints in all seating positions. Head restraints are most effective for protection against whiplash and other rear-impact crash injuries.

The center of the back of the occupant's head should rest against the center of the restraint. The tops of the occupant's ears should be level with the center height of the restraint.

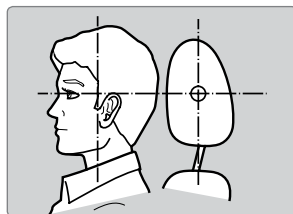

To raise the head restraint: Pull it upward.

To lower the head restraint: Push it down while pressing the release button.

To remove the head restraint: Pull the restraint up as far as it will go. Then push the release button, and pull the restraint up and out.

To reinstall a head restraint: Insert the legs back in place, then adjust the head restraint to an appropriate height while pressing the release button. Pull up on the restraint to make sure it is locked in position.

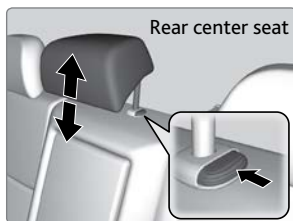

For a head restraint system to work properly:

- Do not hang any items on the head restraints or from the restraint legs.
- Do not place any object between an occupant and the seat-back.
- Install each restraint in its proper location.

⚠️WARNING

Improperly positioning head restraints reduces their effectiveness and increases the likelihood of serious injury in a crash.

Make sure head restraints are in place and positioned properly before driving.

⚠️WARNING

Failure to reinstall, or correctly reinstall, the head restraints can result in severe injury during a crash.

Always replace the head restraints before driving.

■ Floor Mats

Position the front and rear seat floor mats properly, and anchor them. If they are not properly positioned, the floor mats can interfere with the front seat functions.

Do not put additional floor mats on top of the anchored mats.

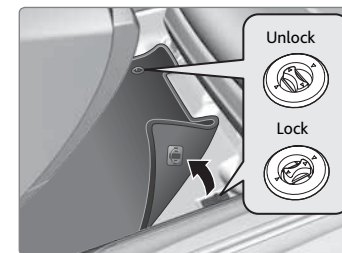

Driving Position Memory System

You can store two driver's seat, steering wheel, and door mirror positions into memory when the vehicle is on. When you unlock and open the driver's door, the driver's seat slides rearward to allow for easy entry. The seat slides forward to the stored position and the other items adjust when the vehicle is turned on. The items adjust automatically to one of the two preset positions.

1. Adjust the seat, steering wheel, and mirrors to your preferred positions.
2. Press SET.
3. Press and hold memory button 1 or 2. You will hear two beeps when the memory is set.

Press one of the memory buttons to recall previously stored positions.

Lumbar positions cannot be stored.

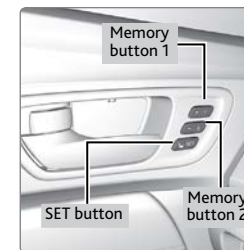

TABLE OF CONTENTS

VISUAL INDEX

SAFETY INFORMATION

INSTRUMENT PANEL

VEHICLE CONTROLS

AUDIO AND CONNECTIVITY

BLUETOOTH® HANDSFREELINK®

ACURALINK®

NAVIGATION

DRIVING

HANDLING THE UNEXPECTED

MAINTENANCE

SPECIFICATIONS

CLIENT INFORMATION

VOICE COMMAND INDEX

INDEX

Adjusting the Steering Wheel

The steering wheel height and distance from your body can be adjusted so that you can comfortably grip the steering wheel in an appropriate driving posture.

1. Pull down the steering wheel adjustment lever.
2. Move the steering wheel up, down, in, or out.
3. Push up the lever to lock the steering wheel in place.

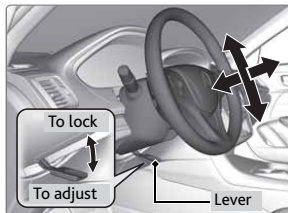

⚠ WARNING

Adjusting the steering wheel position while driving may cause you to lose control of the vehicle and be seriously injured in a crash.

Adjust the steering wheel only when the vehicle is stopped.

■ Heated Steering Wheel*

Canadian models

Heat the steering wheel to a comfortable temperature when the vehicle is on.

Press the heated steering wheel button. Press the button again to turn it off.



*if equipped

Adjusting the Mirrors

Adjust the angle of the mirrors for the best visibility when you are sitting in the correct driving position.

■ Automatic Dimming Rearview Mirror

When driving after dark, the automatic dimming function reduces the glare in the rearview mirror and door mirrors from headlights behind you. This cannot be turned off. The function cancels when the shift lever is in Reverse (R).



■ Power Door Mirrors

Adjust the power door mirrors when the vehicle is on.

L/R selector switch: Select the left or right mirror. After adjusting the mirror, return the switch to the center position.

Mirror position adjustment switch: Press the switch left, right, up, or down to move the mirror.

Folding door mirror button*: Press to fold the door mirrors in or out.

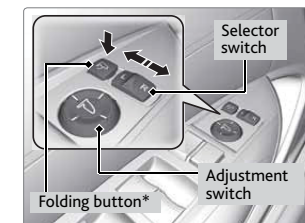

■ Reverse Tilt Door Mirrors

Either side door mirror can tilt downward when you shift to Reverse (R) to improve visibility on the selected side of the vehicle when reversing.

When in Reverse, slide the selector switch to the left or right side. The selected door mirror tilts down.

The mirror returns to its original position when you shift out of Reverse.



*if equipped (Canadian models)

Customized Features

You can easily customize many features of your vehicle. The customized settings are recalled every time you unlock the driver's door with the remote (Driver 1 or Driver 2). Settings are unique to each remote.

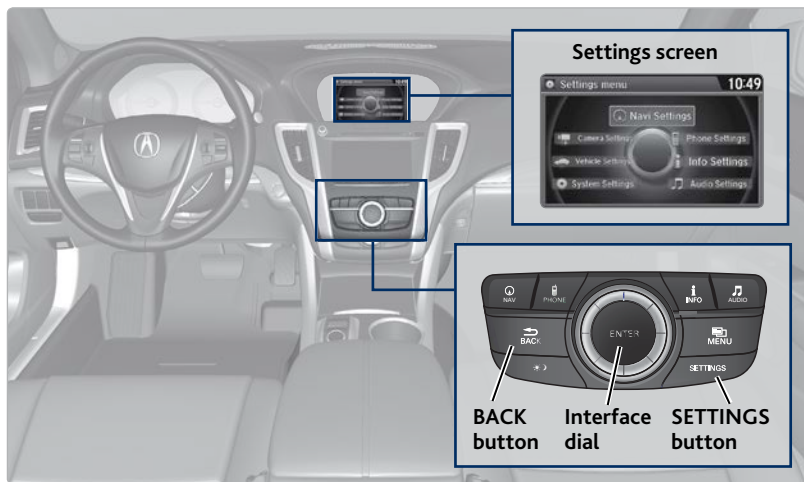

How to Change a Setting

The vehicle must be in Park (P) to select Vehicle Settings. Use the interface dial to make and enter selections.

1. Press SETTINGS.
2. Select an option (System, Vehicle, Camera, Audio, Phone, Info, and Navi*).
3. Select a setting option, and make your preferred changes.
4. Press BACK to exit out of the menus.

Setting the Clock

On vehicles without navigation, use the interface dial to adjust the time in the clock display. On vehicles with navigation, the time is automatically set using GPS signals.

1. Press SETTINGS.
2. Select System Settings
3. Select Clock Adjustment.
4. Rotate the interface dial to change the hour value. Press the interface dial to select minutes, and rotate to change the value. Press the interface dial to exit the screen.
5. Press BACK to exit out of the menus.

**if equipped*

HomeLink® Garage Opener

Program your vehicle to operate up to three remote-controlled devices around your home—such as garage doors, lighting, or home security systems—using the buttons on the ceiling.

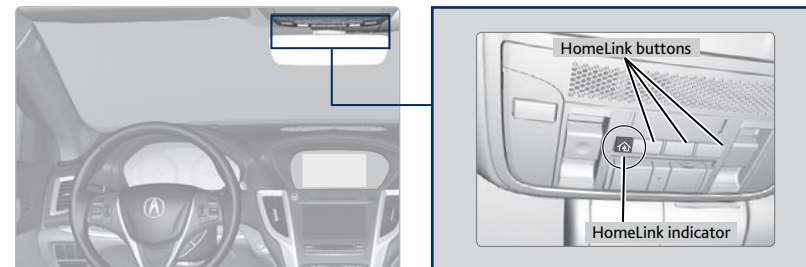

Training a Button

Park near the system you want to program, and follow the instructions in the flowchart below.

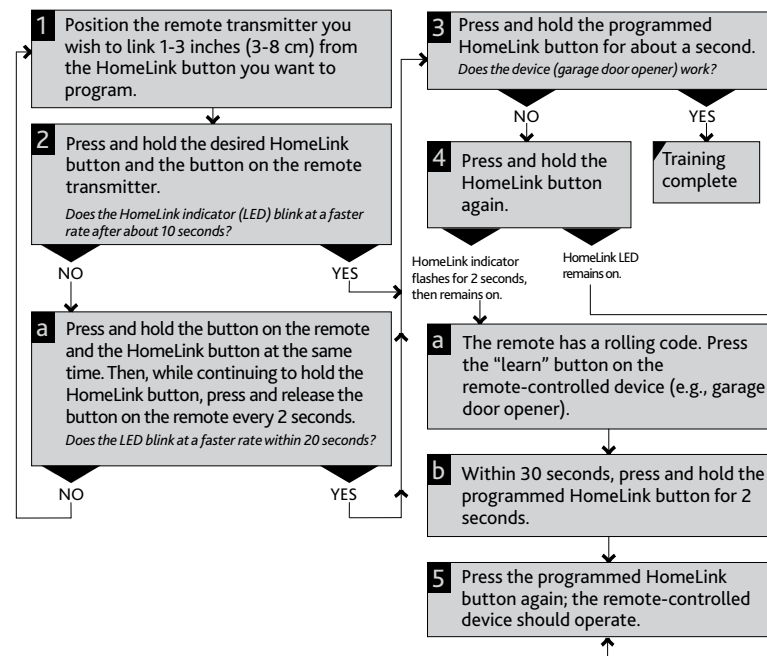

To retrain a button or erase codes, see the Owner's Manual on the Owner Information CD or at owners.acura.com (U.S.) or www.myacura.ca (Canada). If you need help, call HomeLink at (800) 355-3515 or visit www.homelink.com.

Climate Control System

Set your preferred interior temperature by selecting the proper mix of heated or cooled air and fan speed. Use the On-Demand Multi-Use Display (ODMD) or buttons to operate the system.

On-Demand Multi-Use Display (ODMD)
When you select a climate control icon, a new screen appears where you can make adjustments or change settings.

Shortcuts (Climate tab): Store or select two climate control settings.

Airflow control mode

Driver's side temperature

Passenger's side temperature

AC: Turn the air conditioning on or off.

SYNC: Set the passenger's side temperature to the same as the driver's side.

Fan speed

Recirculation/fresh air mode



Climate control buttons

Driver's side temperature switch

ON/OFF button

AUTO button: Press, then adjust the temperature to your preferred setting.

Windshield defroster button

FRONT

REAR

Rear window defogger/heated mirror button

Passenger's side temperature switch

Climate control operation is affected during auto idle stop operation* (see page 83).

*if equipped

Seat Heaters and Ventilation*

Quickly warm or cool the seats when the vehicle is on.

Front Seat Heaters or Ventilation*

Use the On-Demand Multi-Use Display (ODMD) to operate the front seat heaters or ventilation.



ODMD screen

Select to enter the seat heating screen.

Close the menu.

HEAT - +

COOL - +

OFF AUTO

-: Decrease heating or cooling levels.

+: Increase heating or cooling levels.

AUTO*: The system selects the best setting based on ambient temperature.

When the vehicle is turned off, the heating or cooling setting returns to off at the next vehicle start. If AUTO is selected, the setting remains in AUTO.

Rear Seat Heaters*

Canadian models

Use the buttons on the rear of the center console to operate the rear outer seat heaters.

Press either seat heater button to toggle through the HI, MID, LO, or OFF settings. The appropriate indicator appears for each setting.

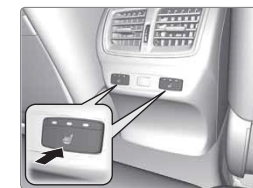

WARNING

Heat-induced burns are possible when using seat heaters. Persons with a diminished ability to sense temperature (e.g., persons with diabetes, lower-limb nerve damage, or paralysis) or with sensitive skin should not use the seat heaters.

*if equipped

AUDIO AND CONNECTIVITY

Learn how to operate the vehicle's audio system.

Basic Audio Operation

Connect audio devices and operate buttons and displays for the audio system.

■ USB Adapter Cable

Connect a USB flash drive or other audio device, such as an iPod® or iPhone®.

1. Slide the front pocket lid forward.
2. Install the flash drive or cable connector to the USB connector.



iPod and iPhone are trademarks of Apple, Inc.

■ Auxiliary Input Jack

Connect standard audio devices with a 1/8-inch (3.5 mm) stereo miniplug.

1. Open the center console. Open the AUX cover.
2. Connect the device to the input jack. Use the device to control the audio.

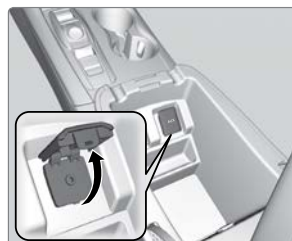

State or local laws may prohibit the operation of handheld electronic devices while operating a vehicle.

■ Steering Wheel Controls

Operate certain functions of the audio system using the steering wheel controls.

SOURCE button: Cycle through available audio modes.

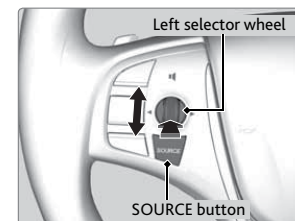

Left selector wheel: Roll up or down to adjust volume. Press to mute. Move (or hold) left or right to change stations or tracks.

FM/AM/XM® Radio

Move right or left for the next or previous station. Move and hold right or left for the next or previous strong station.

CD/HDD*/iPod*/USB/Bluetooth® Audio

Move right or left for the next or previous track. Move and hold right or left for the next or previous folder (CD/USB).

Pandora®

Move right for the next song. Move and hold right or left for the next or previous station.

■ Adjusting the Sound

Adjust various sound settings using these two methods.

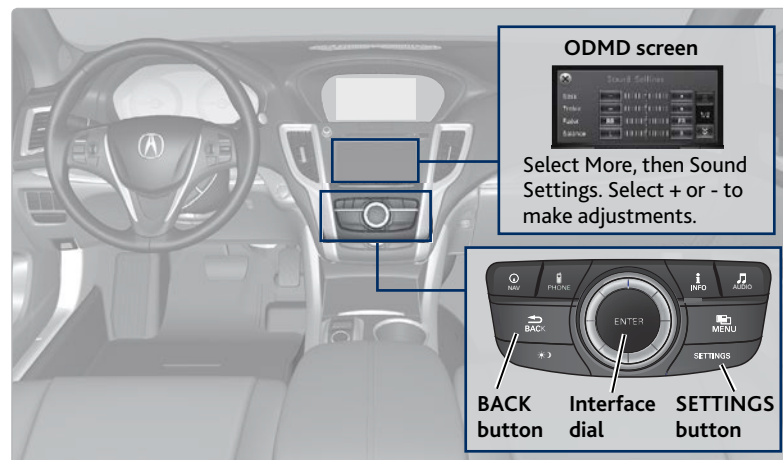

1. Press SETTINGS.
2. Select Audio Settings.
3. Select Sound.
4. Select the setting to adjust.
5. Adjust the setting to the desired level. Press the interface dial.
6. Press BACK to exit the menu.

*if equipped

■ On-Demand Multi-Use Display (ODMD) and Controls

Operate the audio system using either the touchscreen or dashboard buttons.

The functions shown here can be used with most audio sources. Refer to subsequent audio pages for more specific functions. Options that appear depend on the selected audio source.

ODMD controls



Volume knob: Adjust the volume level.

Power button: Turn the audio system on or off.

Audio Source: Change the audio source.

Shortcuts (Audio tab): Store or select up to six AM, FM, or XM stations or HDD tracks.

More: Change screen and sound settings, or display menu options.

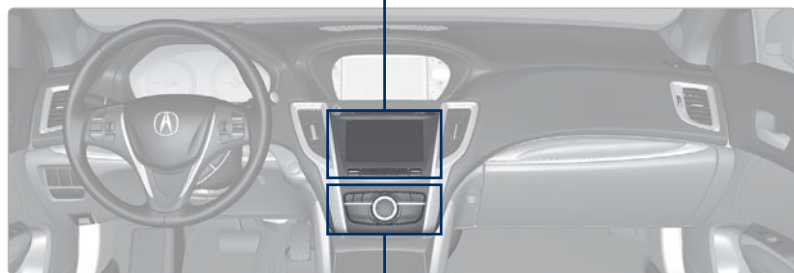

Audio buttons

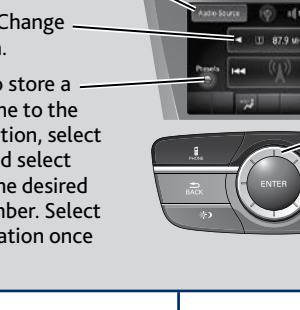

Back button: Return to the previous display.

*** > button:** Adjust the upper screen brightness.

Interface dial (from the Audio screen): Move up, down, left, and right. Rotate and press ENTER to make selections in the upper display.

Audio button: Display the audio screen.

Menu button: Display menu items.

SETTINGS button: Choose Audio Settings.

FM/AM Radio

Play FM or AM radio stations.

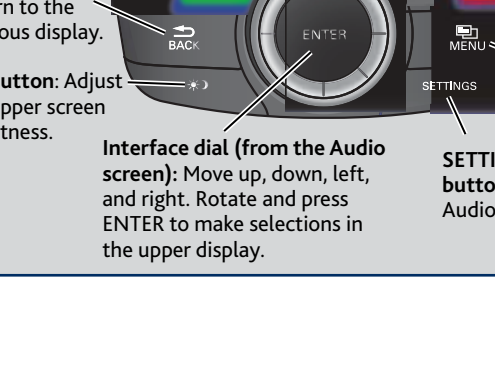

Audio Source: Select the FM or AM icon.

Tune bar: Change the station.

Presets: To store a station, tune to the desired station, select Presets, and select and hold the desired preset number. Select a preset station once stored.

Skip/seek bar: Find a station with a strong signal.

Interface dial (from the Audio screen): Rotate and press to select preset stations in the upper display.



SiriusXM® Radio

Available on a subscription basis only. For more information or to subscribe, contact your dealer or visit www.siriusxm.com (U.S.) or www.siriusxm.ca (Canada).

Audio Source: Select the XM Icon.

Category bar: Change the category.

Presets: To store a station, tune to the desired station, select Presets, and select and hold the desired preset number. Select a preset station once stored.

Skip/seek bar: Change the channel.

Interface dial (from the Audio Screen): Rotate and press to select preset channels in the upper display.



Available in the U.S. and Canada, except Hawaii, Alaska, and Puerto Rico.

XM® is a registered trademark of Sirius XM Radio, Inc.

Compact Disc (CD)

The audio system supports audio CDs, CD-Rs, and CD-RWs in MP3, WMA, or AAC formats.

CD slot

Audio Source: Select the CD icon.

Folder bar: Change the folder.

CD eject button

SKIP/seek bar: Change the track.

Interface dial (from the Audio screen): Rotate to view tracks in the upper display, and press to select a track.



NOTICE

Do not use CDs with adhesive labels or insert a damaged CD. Inserting these types of CDs may cause them to get stuck inside or damage the audio unit.

iPod® or USB Flash Drive

Connect your device to the USB port (see page 44).

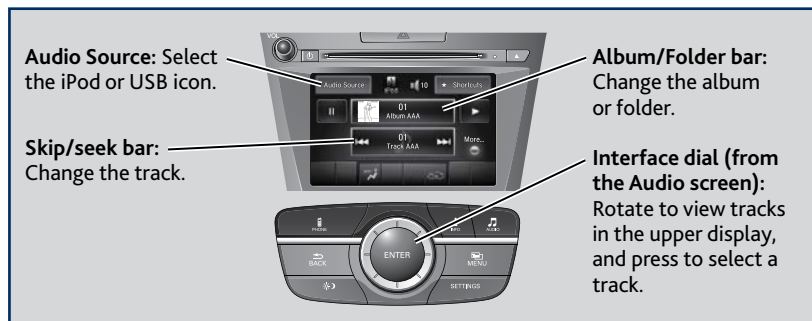

■ Searching for Music

Use the interface dial to search for tracks using several methods.

1. From the audio screen, press MENU.
2. Select Music Search.
3. Select a search type (artist, album, track, etc.) or folder.
4. Select the song you want to play.

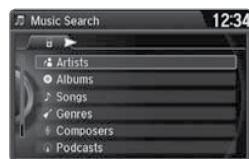

On vehicles with navigation, you can also search for and play iPod music using Song By Voice™ (see page 139).

iPod is a trademark of Apple, Inc.

Bluetooth® Audio

Play streaming or stored audio from your compatible phone when it is paired to *Bluetooth® HandsFreeLink®* (see page 57). Visit www.acura.com/handsfreelink (U.S.) or www.handsfreelink.ca (Canada) to check phone compatibility. Standard data rates may apply.

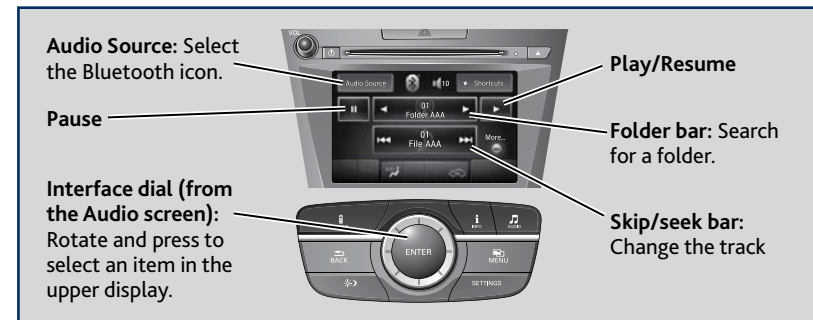

Notes:

- Make sure the volume on your phone is properly adjusted.
- You may need to enable additional settings on your phone for playback.
- The resume/pause function and remote audio controls are not supported on all phones.

State or local laws may prohibit the operation of handheld electronic devices while operating a vehicle. Only launch streaming audio on your phone when safe to do so.

Hard Disc Drive (HDD) Audio*

When music CDs are inserted, they are automatically recorded by system default onto the built-in HDD for later playback.

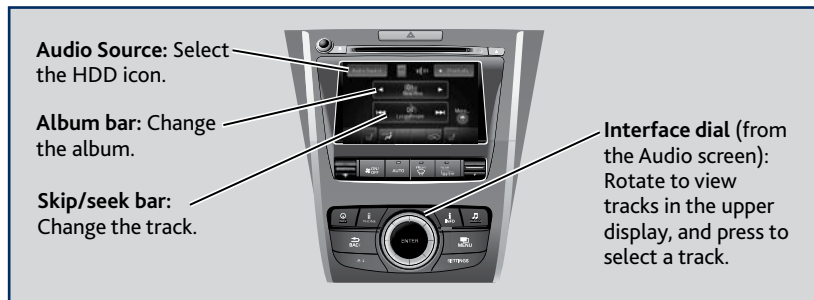

■ Searching for Music

Use the interface dial to search for tracks using several methods.

1. From the audio screen, press MENU.
2. Select Music Search.
3. Select a search type (artist, album, track, etc.).
4. Select the song you want to play.



You can also search for and play HDD music using Song By Voice™ (see page 139).

*if equipped

Pandora®

Play and operate Pandora from your phone through the vehicle's audio system. Visit www.acura.com/handsfreelink to check phone compatibility. Standard data rates apply. Available in the U.S. only.

Connect your phone when the vehicle is stopped.

For iPhone:

- Connect via *Bluetooth*® HandsFreeLink® (see page 57) or USB (see page 44).
- A pop-up may appear on your phone requesting you to allow access for Pandora to be launched.
- If Pandora still does not operate, try rebooting the phone and reconnecting the cable if necessary.

For Android and BlackBerry:

- Connect via *Bluetooth*® HandsFreeLink® (see page 57).

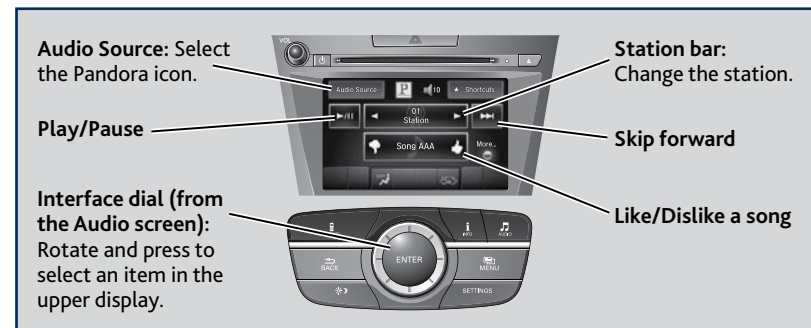

State or local laws may prohibit the operation of handheld electronic devices while operating a vehicle. Only launch streaming audio on your phone when it is safe to do so.

AcuraLink featuring Aha™

Access music and information programming, location-based services, and social media through the vehicle's audio system. Visit www.acura.com/handsfreelink (U.S.) or www.handsfreelink.ca (Canada) to check phone compatibility. Standard data rates apply.

Visit owners.acura.com (U.S.) or www.myacura.ca (Canada) and download the AcuraLink app to your phone prior to using this feature. Make sure you have an active Aha account. Connect your phone when the vehicle is stopped.

For iPhone:

- Connect via **Bluetooth® HandsFreeLink®** (see page 57) or USB (see page 44).
- A pop-up may appear on your phone requesting you to allow access for Aha to be launched.
- If Aha still does not operate, try rebooting the phone and reconnecting the cable if necessary.

For Android and BlackBerry:

- Connect via **Bluetooth® HandsFreeLink®** (see page 57).

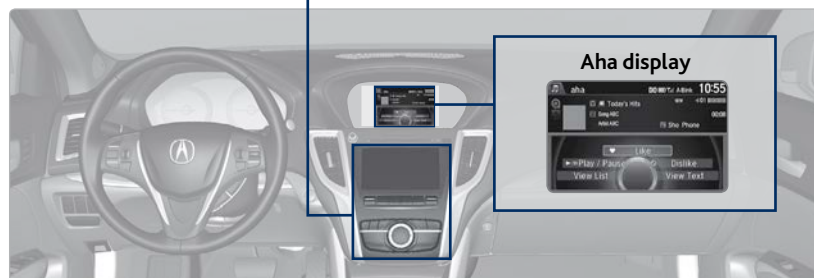

State or local laws may prohibit the operation of handheld electronic devices while operating a vehicle. Only launch streaming audio on your phone when it is safe to do so.

BLUETOOTH® HANDSFREELINK®

Learn how to operate the vehicle's hands-free calling system.

Basic HFL Operation

Make and receive phone calls using the vehicle's audio system, without handling your phone. Visit www.acura.com/handsfreelink (U.S.) or www.handsfreelink.ca (Canada) to check phone compatibility.

To reduce the potential for driver distraction, certain manual functions may be inoperable or grayed out while the vehicle is moving. Voice commands are always available.

■ HFL Displays and Controls

Use the controls to enter information and make selections.

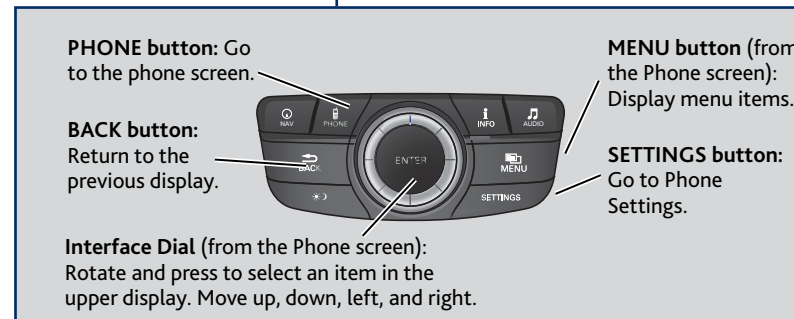
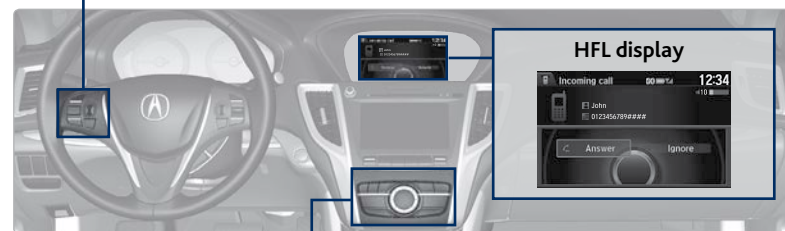
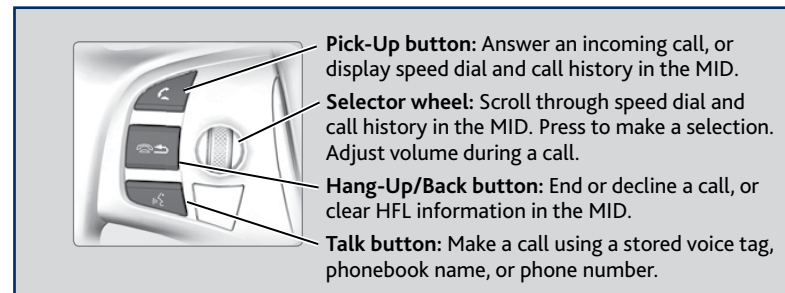

TABLE OF CONTENTS

VISUAL INDEX

SAFETY INFORMATION

INSTRUMENT PANEL

VEHICLE CONTROLS

AUDIO AND CONNECTIVITY

BLUETOOTH® HANDSFREELINK®

ACURALINK®

NAVIGATION

DRIVING

HANDLING THE UNEXPECTED

MAINTENANCE

SPECIFICATIONS

CLIENT INFORMATION

VOICE COMMAND INDEX

INDEX

On-Demand Multi-Use Display (ODMD) Screens



When there is an incoming call, select the green Pick-Up or red Hang-Up icon.



When a number keypad is displayed, select numbers to enter.



When an alphabet keyboard is displayed, select letters to enter.

■ Voice Command Tips

- When using the Talk button, wait for a beep before saying a command.
- To bypass the system prompts, simply press the Talk button again to say your command.
- When the Talk button is pressed, all available voice commands are highlighted in yellow.
- Speak in a clear, natural voice.
- Reduce all background noise.
- Adjust the dashboard and side vents away from the microphone in the ceiling. Fan speed may be temporarily reduced during voice recognition operation.
- Close the windows and moonroof.

Pairing a Phone

To use hands-free phone and streaming audio functions, you must first pair your phone to the system. This can only be done when the vehicle is stopped. Use the interface dial to make and enter selections.

1. Press SETTINGS.
2. Select Phone Settings.
3. Select Bluetooth Device List (if no phone has been paired) or Connect Phone (if pairing an additional phone).
4. Select Add Bluetooth Device.
5. Make sure your phone is in discovery mode.
6. HFL searches for your phone. Select your phone when it appears on the list.
If your phone does not appear: Select Device Not Found and search for HandsFreeLink from your phone.
7. HFL gives you a six-digit code. Compare it to the code that appears on your phone. Connect to HFL from your phone.
8. The system asks if you want to enable Phone Synchronization, which imports your phone's call history and phonebook. Select On.
9. Press BACK to exit the menu.



Making a Call

You can make calls using several methods.

■ Dialing a Number

Enter a 10-digit phone number to call.

Using Voice Commands

Press the Talk button before saying each command.

1. Say "Dial by number."
2. Say the phone number. For example, "3-1-0-5-5-5-1-2-3-4." Say "Dial" if necessary.
3. The system begins to dial.



Using the Menu

Use the interface dial to make and enter selections. This is inoperable while the vehicle is moving.

1. Press PHONE.
2. Press MENU.
3. Select Dial.
4. From the navigation screen or the ODMD, enter the phone number. Select the green phone icon to call.



Using the ODMD

Select items on the screen by touching them. This is inoperable while the vehicle is moving.

1. Select Shortcuts.
2. Select Phone.
3. Select Dial.
4. Enter the phone number and select the green phone icon to call.



■ Using the Phonebook

When your phone is paired, its entire phonebook can be automatically imported to the system if you select On for Phone Synchronization.

Using Voice Commands

Press the Talk button before saying each command.

1. Say "Call by name."
2. Say the phonebook name and phone type. For example, "John Smith mobile."



Using the Menu

Use the interface dial to make and enter selections. This is inoperable when the vehicle is moving.

1. Press PHONE.
2. Press MENU.
3. Select Phonebook.
4. Scroll through the list to find the name and number you want to call, and select it to call.



■ Storing Speed Dial Entries

Store up to 20 numbers for quick dialing. Use the interface dial to make and enter selections.

1. Press PHONE.
2. Press MENU.
3. Select Speed Dial, then select New Entry.
4. Choose an entry method.
5. If desired, you can create a voice tag for the number. Follow the prompts.



When a voice tag is created, you can press the Talk button and say "Call" and the stored voice tag.

When speed dial entries are stored, you can add them to the Shortcuts (Phone tab) in the ODMD for quick access.

Using Speed Dial and Call History

Make calls quickly using stored speed dial entries or call history numbers.

Using Voice Commands

Press the Talk button before saying each command.

1. Say "Call by name."
2. Say the name of the stored voice tag.
3. The system begins to dial.



Using the MID

Press the Pick-Up button on the steering wheel.

1. The speed dial list appears in the MID. For Call History, move the left selector wheel to the right.
2. Use the left selector wheel to scroll through the list to find the entry you want to call, and select it to call.

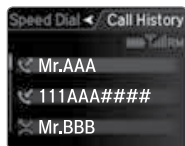

Using the Phone Screen

Use the interface dial to make and enter selections.

1. Press PHONE.
2. For Speed Dial, use the interface dial to scroll through the list to find the entry you want to call, and select it to call. For Call History, move the interface dial to the right and scroll through the list.



Using the ODMD

Select items on the screen by touching them.

1. Select Shortcuts.
2. Select Phone.
3. Select Speed Dial or Call History. Speed dial entries must be previously stored to the Shortcuts menu. Select Edit and follow the prompts.
4. Select the desired entry to call.



SMS Text Messaging and E-Mail

Receive and send text messages and e-mails from your paired and linked phone. Visit www.acura.com/handsfreelink (U.S.) or www.handsfreelink.ca (Canada) to check phone compatibility. Standard message rates apply. This feature is limited while the vehicle is moving.

Selecting an Account

If your phone has both text message and mail accounts, you can select only one of them at a time to be active and receive notifications.

1. Press SETTINGS.
2. Select Phone Settings.
3. Select Select Account.
4. Select Text Messages or an e-mail account.

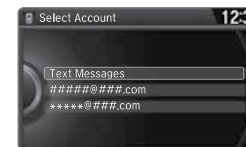

Receiving and Responding to Messages

When you receive a new message, a pop-up appears in the upper display. Use the interface dial to view the message when the vehicle is stopped. You can also reply to it using fixed phrases or call the sender.

1. When the prompt appears, select Read.
2. The message is displayed, and the system reads it aloud.
3. **To reply:** Select Reply, and choose one of the six available responses. Select Send to send the message. You cannot create a new message. **To call the sender:** Select Call.



ACURALINK®*

Learn about Acura's advanced connectivity services.

AcuraLink Messages

Receive messages on vehicle features, safety and emissions recall campaigns, maintenance reminders, and diagnostic information. Some message features require a phone connection. Visit www.acura.com/handsfreelink (U.S.) or www.handsfreelink.ca (Canada) to check phone compatibility.

Viewing Messages

When you receive a new message, an icon appears on the upper right corner of the upper screen. Use the interface dial to make and enter selections.

1. Press INFO.
2. Select AcuraLink Messages.
3. Select a message category.
4. Select a message.
5. Select Voice to hear the entire message details read aloud.

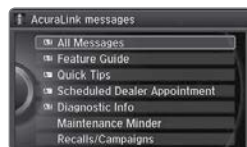

Message Options

When you receive certain messages, you can call your dealer if your phone is paired to the system, find the nearest dealer, or schedule service appointments. A current AcuraLink subscription is required to set up this feature and modify your message preferences.



*if equipped

Subscription Features

A subscription-based service that provides convenient features, such as collision notification, emergency assistance, online security, and important messages about your vehicle. Requires enrollment and privacy agreement. To subscribe or get more information, contact a dealer or visit owners.acura.com (U.S.) or www.myacura.ca (Canada).

Emergency Assistance

If your vehicle's airbags deploy or if the unit detects that the vehicle is severely impacted, your vehicle automatically attempts to connect to the AcuraLink operator if there is cellular coverage. Once connected, information about your vehicle, its positioning, and its condition will be sent to the operator. You can also speak to the operator when connected.

To manually connect to the operator, open the cover on the ceiling console and press ASSIST when the vehicle is on.

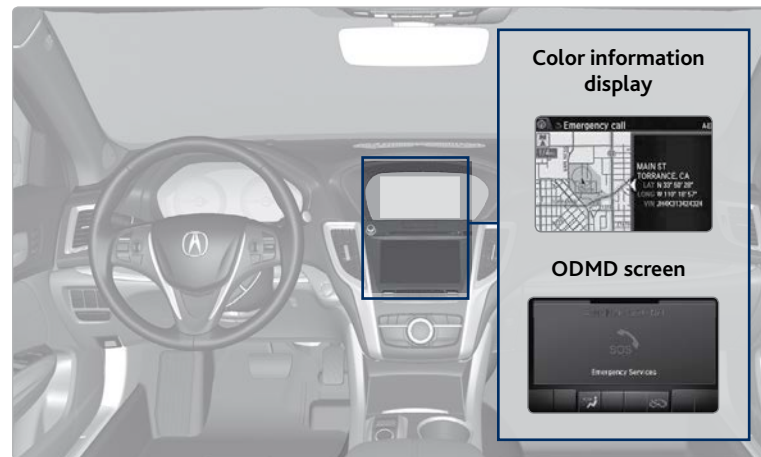

Color information display



ODMD screen



■ Security Features

To use security features, you need your user ID and personal identification number (PIN). Some of these features are also available with the AcuraLink smartphone app. Visit owners.acura.com/apps to download the app.

- *Stolen vehicle tracking:* Searches and tracks down your vehicle position.
- *Remote door lock/unlock:* Remotely lock or unlock doors.
- *Vehicle finder:* Locate your vehicle in large areas, such as a parking lot.
- *Security alarm notification:* If your vehicle's security system detects tampering, the provider notifies you.

■ Operator Assistance

Connect to the AcuraLink operator when trying to find a destination or for roadside assistance.

Press LINK to connect to an operator.



NAVIGATION*

Learn how to enter a destination and operate the navigation system.

Basic Navigation Operation

A real-time navigation system uses GPS and a map database to show your current location and help guide you to a desired destination. You can operate the system using voice commands or the system controls.

To reduce the potential for driver distraction, certain manual functions may be inoperable or grayed out while the vehicle is moving. Voice commands are always available.

■ Steering Wheel Controls

Use the steering wheel controls to give voice commands.

Hang-Up/Back button: Press to cancel a command or operation.

Talk button: Press to say navigation commands.

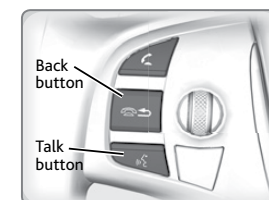

■ Voice Command Tips

- When using the Talk button, wait for a beep before saying a command.
- To bypass the system prompts, simply press the Talk button again to say your command.
- When the Talk button is pressed, all available voice commands are highlighted in yellow.
- Speak in a clear, natural voice.
- Reduce all background noise.
- Adjust the dashboard and side vents away from the microphone in the ceiling. Fan speed may be temporarily reduced during voice recognition operation.
- Close the windows and moonroof.

⚠ WARNING

Using the navigation system while driving can take your attention away from the road, causing a crash in which you could be seriously injured or killed.

Only operate system controls when the conditions permit you to safely do so.

*if equipped

Navigation Display and Controls

Use the controls to enter information and make selections. Some manual functions are inoperable while driving.

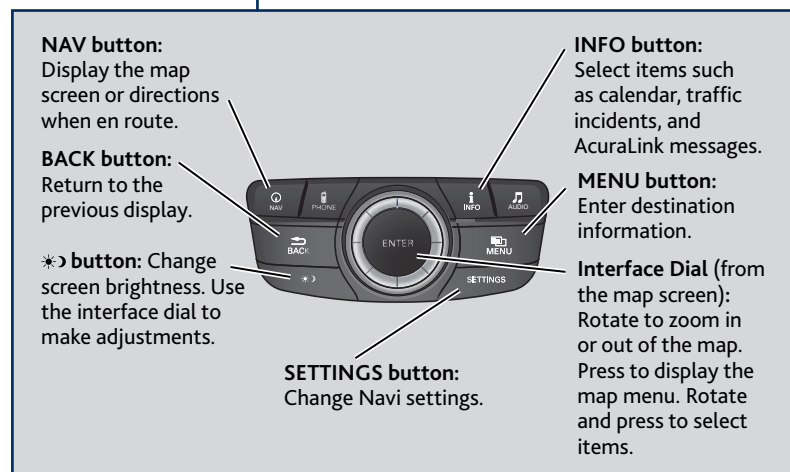
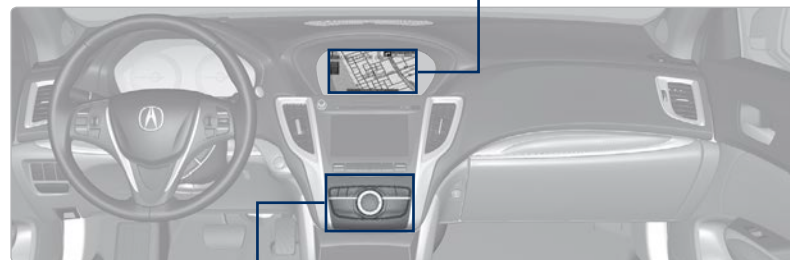
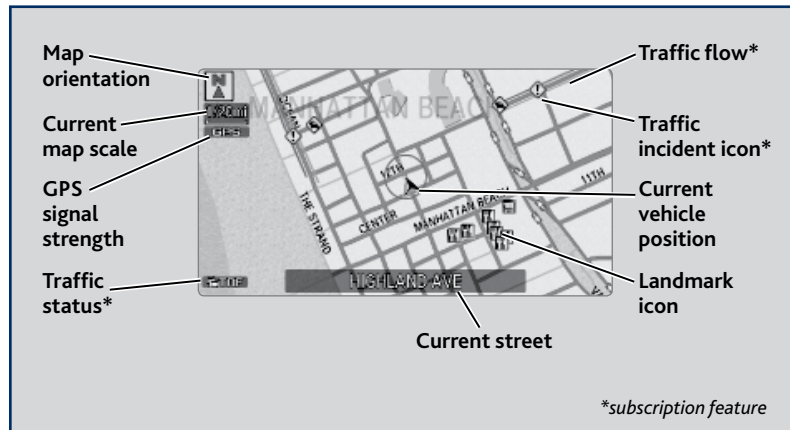

Interface Dial Feedback

Configure the system to read aloud selections made using the interface dial. Use the interface dial to make and enter selections.

1. Press SETTINGS.
2. Select System Settings.
3. Select Interface Dial Feedback.
4. Select Off, Auto, or On.



On: Always reads the selection.
Auto: Reads the selection only when the vehicle is moving.
Off: Turns interface dial feedback off.

System Guidance Volume

Adjust the navigation system guidance volume. This does not affect audio or Bluetooth® HandsFreeLink® volume, which is controlled by the volume knob. Use the interface dial to make and enter selections.

1. From the map screen, press the interface dial to display the map menu.
2. Select Guidance Volume.
3. Adjust the volume to your preferred level.
4. Press BACK to exit the menu.



Voice Prompt

Turn the voice prompt feature on or off. Use the interface dial to make and enter selections.

1. Press SETTINGS.
2. Select System Settings.
3. Select Voice Prompt.
4. Select Off or On.
On: Provides voice prompts.
Off: Voice prompts are disabled.



Entering a Destination

Use several methods to enter a destination.

Home Address

Store your home address in the system so you can easily route to it. Use the interface dial to make and enter selections.

1. Press SETTINGS.
2. Select Navi Settings.
3. Select Edit Go Home.
4. Enter the address and select OK.



When your home address is stored, you can press the Talk button and say "Go home" at any time. You can also select Go Home from the destination menu.

Street Address

Enter a street address using voice commands. Press the Talk button before saying each command.

You can also enter the address manually when the vehicle is stopped. While on the map screen, press MENU and use the interface dial to select Address. Follow the prompts.

U.S. models

1. From the Voice Portal screen, say "Address."
2. The system prompts you to say the entire address. For example, say "1-2-3-4 Main Street, Los Angeles, California."
3. The system interprets the address by state, city, street, and address number. If necessary, you may have to clarify similar matches.
4. Say "Set as destination" to set the route.

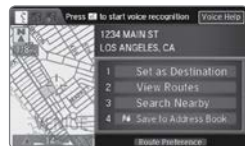

Canadian models

From the map screen, say "Display Menu," followed by "Address." Follow the prompts.

Place Category

Enter a point of interest using voice commands. Press the Talk button before saying each command.

1. From the Voice Portal, say "Place name."
2. Say a category. For example, "ATM/Bank."
3. Say the name of the point of interest. For example, "ABC Bank."
4. The system interprets the name. If necessary, you may have to clarify similar matches.



If there is more than one point of interest with the name, a list of matches appears in order of closest distance. Say the number next to the place you want.

5. Say "Set as destination" to set the route.



If the system does not recognize the specific name, you can enter it manually when the vehicle is stopped. While on the map screen, press MENU and use the interface dial to select Place Name. Enter the name one letter at a time, and follow the prompts.

Find Nearest Place

Enter a destination by category and distance using voice commands. Press the Talk button before saying each command.

1. Say "Find nearest" and a place. For example, "Find nearest ATM."
2. A list of the nearest places in your area is displayed by shortest distance to destination.
3. Say the number next to the destination you want to select.
4. Say "Set as destination" to set the route.



ODMD Shortcuts

You can add up to six destinations to the Shortcuts (Places tab) in the ODMD. The addresses must be previously stored in the navigation system address book.

1. Select Shortcuts.
2. Select Places.
3. Select No Entry to store a previously stored address book entry, or select a stored entry to route to it.



Routing

After a destination is set, you can alter or cancel your route.

Map Legend

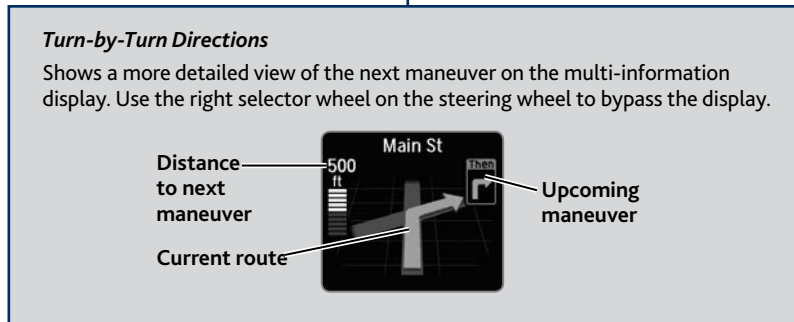
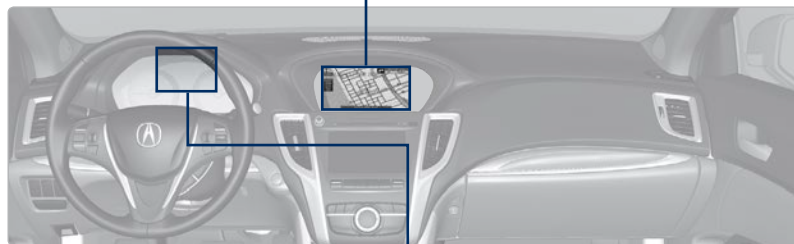
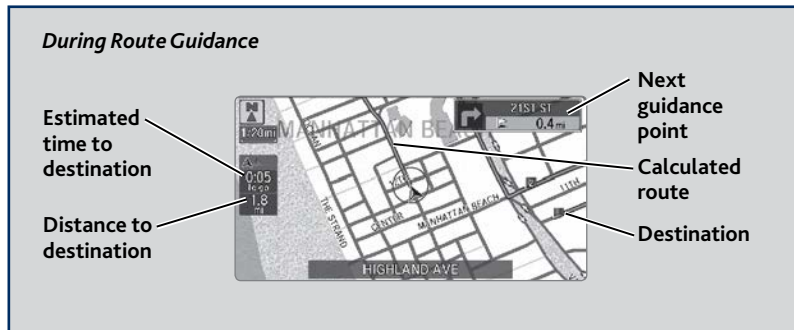

Taking a Detour

You can calculate a detour route manually if you encounter a road closure or other obstacle. Use the interface dial to make and enter selections.

1. When en route, press MENU.
2. Select Detour. The system attempts to calculate a new route by avoiding the next 5 miles (8 km) while on a freeway or 1 mile (1 km) while on a surface street.



AcuraLink Real-Time Traffic™*

View traffic flow, incidents, and construction in major metro areas. You can also route around congestion or incidents using voice commands. Press the Talk button before saying each command. **Available in the U.S. only.**

1. When en route, say “Display traffic on my route.” A list of incidents on your route appears.
2. Say the number of the incident you want to avoid.
3. Say “Avoid” and the incident list returns.
4. Say “Reroute” to set the new route.



*Requires AcuraLink subscription.

Canceling Your Route

You can cancel your route at any time. Press the Talk button and say “Cancel route.” You can also use the interface dial to make and enter selections.

1. When en route, press MENU.
2. Select Cancel Route. The route is cleared and the map screen returns.



DRIVING

Learn about preparation for driving, as well as other features.

Before Driving

Check the following items before you begin driving.

■ Exterior Checks

- Make sure there are no obstructions on the windows, door mirrors, exterior lights, or other parts of the vehicle.
- Remove any frost, snow, or ice.
- Make sure the hood is securely closed.
- Heat from the engine and exhaust can ignite flammable materials left under the hood, causing a fire. If you've parked your vehicle for an extended period, inspect and remove any debris that may have collected, such as dried grass and leaves that have fallen or have been carried in for use as a nest by a small animal. Also check under the hood for leftover flammable materials after you or someone else has performed maintenance on your vehicle.
- Make sure the tires are in good condition.
- Make sure there are no people or objects behind or around the vehicle.

NOTICE

If the doors are frozen shut, use warm water around the door edges to melt any ice. Do not try to force them open, as this can damage the rubber trim around the doors. When done, wipe dry to avoid further freezing.

■ Interior Checks

- Store or secure all items on board properly.
- Do not pile items higher than the seat height.
- Do not place anything in the front seat footwells. Secure the floor mats.
- If you have any animals on board, do not let them move freely in the vehicle.
- Securely close and lock all doors and the trunk.
- Adjust your seating position, mirrors, and steering wheel properly.
- Make sure items placed on the floor behind the front seats cannot roll under the seats.
- Everyone in the vehicle must fasten their seat belt.

Make sure that the indicators in the instrument panel come on when you start the vehicle, and go off soon after.

In addition:

- During the first 600 miles (1,000 km) of operation, avoid sudden acceleration or full throttle operation so as to not damage the engine or powertrain.
- Avoid hard braking for the first 200 miles (300 km). You should also follow this when the brake pads are replaced.

Maximum Load Limit

Carrying too much cargo or improperly storing it can affect your vehicle's handling, stability, stopping distance, and tires, and make it unsafe.

Your vehicle is not designed to tow a trailer. Attempting to do so can void your vehicle warranties.

The maximum load for your vehicle is 850 lbs (385 kg). See the Tire and Loading Information label on the driver's doorjamb.

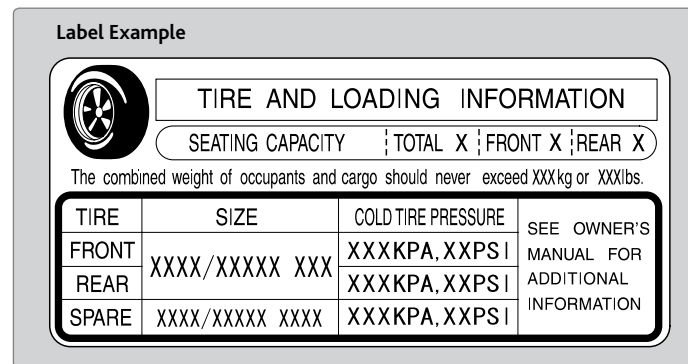





This figure includes the total weight of all occupants, cargo, and accessories, and the tongue load if you are towing a trailer. Below are the steps for determining the correct load limit:

1. Locate the statement "The combined weight of occupants and cargo should never exceed XXX kg or XXX lbs." on your vehicle's placard.
2. Determine the combined weight of the driver and passengers that will be riding in your vehicle.
3. Subtract the combined weight of the driver and passengers from XXX kg or XXX lbs.
4. The resulting figure equals the available amount of cargo and luggage load capacity. For example, if the "XXX" amount equals 1,400 lbs. and there will be five 150 lb. passengers in your vehicle, the amount of available cargo and luggage load capacity is 650 lbs. (1,400 - 750 (5 x 150) = 650 lbs.)
5. Determine the combined weight of luggage and cargo being loaded on the vehicle. That weight may not safely exceed the available cargo and luggage load capacity calculated in step 4.
6. If your vehicle will be towing a trailer, load from your trailer will be transferred to your vehicle. Consult the Owner's Manual to determine how this reduces the available cargo and luggage load capacity of your vehicle.

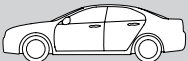
In addition, the total weight of the vehicle, all occupants, accessories, cargo, and trailer tongue load must not exceed the Gross Vehicle Weight Rating (GVWR) or the Gross Axle Weight Rating (GAWR). Both are on a label on the driver's doorjamb.

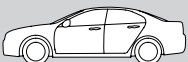
Load Limits Example

| | | |
|---|---|---|
| <p>Example 1</p>  <p>Max load 850 lbs (385 kg)</p> | <p>≡</p>  <p>Passenger weight 150 lbs x 2 = 300 lbs (68 kg x 2 = 136 kg)</p> | <p>+</p>  <p>Cargo weight 550 lbs (249 kg)</p> |
| <p>Example 2</p>  <p>Max load 850 lbs (385 kg)</p> | <p>≡</p>  <p>Passenger weight 150 lbs x 5 = 750 lbs (68 kg x 5 = 340 kg)</p> | <p>+</p>  <p>Cargo weight 100 lbs (45 kg)</p> |

⚠ WARNING

Overloading or improper loading can affect handling and stability and cause a crash in which you can be hurt or killed.

Follow all load limits and other loading guidelines in this manual.

The headlight aim on your vehicle was set by the factory, and does not need to be adjusted. However, if you regularly carry heavy items in the trunk, have the aiming readjusted at your dealer or by a qualified technician.

Remote Engine Start*

Start your vehicle's engine using the two-way remote transmitter from extended distances before you enter the vehicle.



- Amber indicator:** Remote is communicating with the vehicle.
- Green indicator:** Confirms doors are locked or engine is running.
- ENGINE button:** After pressing the Lock button, press and hold to start the engine.
- Red indicator:** Remote is out of range or cannot communicate with the vehicle, or the engine is stopped.
- Lock button**

Make sure the vehicle is in a safe location when using remote engine start (i.e., a well ventilated area, away from flammable materials).

■ **Starting the Engine**

Press the Lock button, then press and hold the ENGINE button.

The engine runs for up to 10 minutes. To extend the time for another 10 minutes, repeat the procedure during the initial 10 minutes.

While the engine is running, the climate control system adjusts the interior temperature, the security system remains on, and lights and accessories remain off.

■ **Stopping the Engine**

Press and hold the ENGINE button.

The engine will also stop if it has been running for more than 10 minutes, or if any door is opened without using the remote transmitter or keyless access.

⚠ WARNING

Carbon monoxide gas is toxic and can rapidly accumulate in closed or even partly enclosed areas. Breathing it can cause unconsciousness and even kill you.

Never use the remote engine starter with the vehicle in a garage or other areas with limited ventilation.

*if equipped

TABLE OF CONTENTS

VISUAL INDEX

SAFETY INFORMATION

INSTRUMENT PANEL

VEHICLE CONTROLS

AUDIO AND CONNECTIVITY

BLUETOOTH® HANDSFREELINK®

ACURALINK®

NAVIGATION

DRIVING

HANDLING THE UNEXPECTED

MAINTENANCE

SPECIFICATIONS

CLIENT INFORMATION

VOICE COMMAND INDEX

INDEX

Starting to Drive

The keyless access system allows simple push-button start.

■ Before Starting the Engine

Press the brake pedal. Keep your foot firmly on the brake pedal when starting the engine.

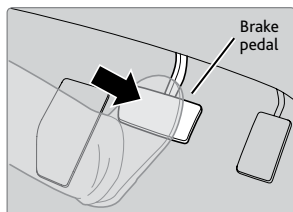

The engine is harder to start in cold weather and in thinner air found at altitudes above 8,000 feet (2,400 m). When starting the engine in cold weather, turn off all electrical accessories such as the lights, climate control system, and rear defogger in order to reduce battery drain.

■ Changing the Power Mode

Accessory or On Mode: Press ENGINE START/STOP once without pressing the brake pedal for Accessory mode. Press it again for On mode.

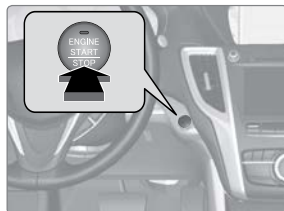

Starting the engine: Press and hold the brake pedal, then press ENGINE START/STOP. Keep your foot firmly on the brake pedal when starting the engine.

Turning the vehicle off: Shift to or select Park, then press ENGINE START/STOP. If you press the button and the shift lever is not in Park, the vehicle goes into Accessory mode.

Shifting

Change your vehicle's gears to begin driving.

■ Shift Lever*

4-cylinder models

Park (P): Used for parking or starting/stopping the engine. Press the brake pedal, then press the release button to shift.

Reverse (R): Used for reversing.

Neutral (N): Used for idling.

Drive (D): Used for normal driving or sequential shift mode (see page 78).



NOTICE

When you change the shift lever from D to R and vice versa, come to a complete stop and keep the brake pedal depressed. Operating the shift lever before the vehicle has come to a complete standstill can damage the transmission.

Do not operate the shift lever while pressing the accelerator pedal. You could damage the transmission.

*if equipped

Sequential Shift Mode*

4-cylinder models

Use the paddle shifters to change between 1st and 8th gears without removing your hands from the steering wheel.

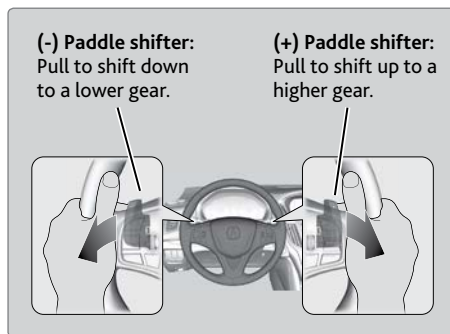

Recommended shift points

| Shift up | Acceleration |
|------------|------------------|
| 1st to 2nd | 15 mph (24 km/h) |
| 2nd to 3rd | 25 mph (40 km/h) |
| 3rd to 4th | 40 mph (64 km/h) |
| 4th to 5th | 45 mph (72 km/h) |
| 5th to 6th | 50 mph (80 km/h) |
| 6th to 7th | 55 mph (89 km/h) |
| 7th to 8th | 60 mph (97 km/h) |

When the shift lever is in D: The vehicle goes into sequential shift mode momentarily, and the gear indicator comes on. When you start driving at a constant speed, sequential shift mode automatically switches off, and the gear indicator goes off.

When the shift lever is in D (with SPORT+ mode): The vehicle goes into sequential shift mode, and the M (sequential shift) indicator and gear indicator come on. At speeds of 2 mph (4 km/h) or less, the vehicle automatically shifts down into 1st gear.

To cancel this mode, press the IDS button (see page 84) to select a different mode. When sequential shift mode is canceled, the M indicator and gear indicator go off.

Second gear lock mode (in SPORT+ mode): If you pull the (+) paddle shifter while stopped or driving at 6 mph (10 km/h) or less, the gear is locked in 2nd gear. This makes it easier to pull away on slippery surfaces such as snow-covered roads. To cancel 2nd gear lock mode, pull the (-) paddle shifter.

Electronic Gear Selector*

6-cylinder models

Select the vehicle's gear using a simple button interface. Apply the brake pedal and select a gear.

Park (P): Press to put the vehicle in Park. A red indicator appears.

Reverse (R): Pull back to put the vehicle in Reverse. A green indicator appears.

Neutral (N): Press to put the vehicle in Neutral. A red indicator appears.

Drive (D): Press to put the vehicle in Drive. A green indicator appears. Release the electric parking brake to begin driving (see page 81).



In freezing or sub-freezing conditions, the electronic gear selector response may be slow. Always apply the brake pedal before shifting into Park (P), and confirm that (P) is shown on the gear position indicator before releasing the brake.

WARNING

The vehicle can roll away if left unattended without confirming that Park (P) is engaged. Always keep your foot on the brake pedal until you have confirmed that (P) is shown on the gear position indicator.

NOTICE

When you change from D to R and vice versa, or want to change to Park (P), come to a complete stop and keep the brake pedal applied. Operating the gear buttons before the vehicle has come to a complete standstill can damage the transmission.

Auto Park Mode

For your convenience, Park (P) is automatically engaged when the vehicle is turned off, or when all of the following conditions are met: the vehicle is stopped, the driver's seat belt is unbuckled, and the driver's door is opened. You should always apply the brake and shift to Park when idling, or before exiting the vehicle.

If you select any gear other than Park when the driver's door is opened and the driver's seat belt is unbuckled, Park is reengaged when the brake pedal is released.

*if equipped

*if equipped

Car Wash Mode

Follow the procedure below to use a conveyor-style car wash where you or an attendant do not remain in the vehicle. Make sure the wiper lever is in the OFF position (see page 33). You should inform the car wash attendant of this procedure.

1. When the engine is running, apply the brake pedal and select Neutral (N).
2. Within 5 seconds, press the ENGINE START/STOP button. The vehicle goes into Accessory mode.

This mode lasts for 15 minutes before the gear changes to Park and the vehicle turns off.

Sequential Mode*

6-cylinder models

Use the paddle shifters to change between 1st and 9th gears without removing your hands from the steering wheel.

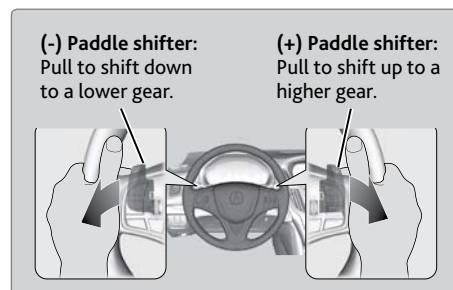

Recommended shift points

| Shift up | Acceleration |
|------------|-------------------|
| 1st to 2nd | 15 mph (24 km/h) |
| 2nd to 3rd | 25 mph (40 km/h) |
| 3rd to 4th | 40 mph (64 km/h) |
| 4th to 5th | 45 mph (72 km/h) |
| 5th to 6th | 50 mph (80 km/h) |
| 6th to 7th | 55 mph (89 km/h) |
| 7th to 8th | 60 mph (97 km/h) |
| 8th to 9th | 65 mph (105 km/h) |

When the gear is in D: The vehicle goes into sequential mode momentarily, and the gear indicator comes on. When you start driving at a constant speed, sequential mode automatically switches off, and the gear indicator goes off.

When the gear is in D (with SPORT+ mode): The vehicle goes into sequential mode, and the M (sequential mode) indicator and gear indicator come on.

To cancel this mode, press the IDS button (see page 84) to select a different mode. When sequential mode is canceled, the M indicator and gear indicator go off.

*if equipped

Braking

Slow down or stop your vehicle, and keep it from moving when parked.

Foot Brake

Press the brake pedal to slow down or stop your vehicle from moving.

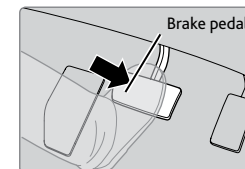

Brake Assist System

During hard or emergency braking, the system increases braking force. The brake pedal may move slightly or make a noise; this is normal. Continue to hold the brake pedal firmly down.

Anti-Lock Brake System (ABS)

During hard or emergency braking, the system rapidly pumps the brakes to prevent wheel lockup and help you maintain steering control. The brake pedal may pulsate slightly during ABS operation; this is normal. Do not pump the brake pedal, and continue to hold it firmly down.

NOTICE

The ABS may not function correctly if you use an incorrect tire type and size.

Electric Parking Brake

Keep your vehicle from moving while parked using a simple switch.

To apply: Pull up the switch. The PARK indicator appears in the instrument panel.



To release: Press the brake pedal and make sure your seat belt is fastened. Press the switch down to release.



You can also lightly press the accelerator pedal if your seat belt is fastened and the vehicle is on and in Drive (D) or Reverse (R).

■ Automatic Brake Hold

Maintains rear brake hold even after the brake pedal is released. Make sure the vehicle is on and your seat belt is fastened when operating this feature.

1. Press BRAKE HOLD. The BRAKE HOLD indicator appears in the instrument panel.
2. With Drive (D) selected, press the brake pedal and come to a complete stop. The HOLD indicator appears, and brake hold is applied. Release the brake pedal.

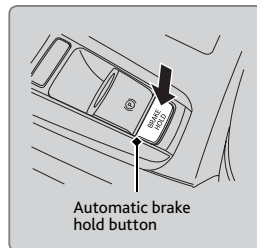

Press the accelerator pedal to cancel brake hold and start moving.

To turn off brake hold: Press the brake pedal and press BRAKE HOLD again.

Automatic brake hold cancels when:

- Braking is applied for more than 10 minutes.
- The driver's seat belt is unfastened.
- The engine is turned off.

⚠ WARNING

Using the automatic brake hold system on steep hills or slippery roads may still allow the vehicle to move if you remove your foot from the brake pedal.

If a vehicle unexpectedly moves, it may cause a crash resulting in serious injury or death.

Never use the automatic brake hold system or rely on it to keep a vehicle from moving when stopped on a steep hill or slippery roads.

⚠ WARNING

Using the automatic brake hold system to park the vehicle may result in the vehicle unexpectedly moving.

If a vehicle moves unexpectedly, it may cause a crash, resulting in serious injury or death.

Never leave the vehicle when braking is temporarily kept by automatic brake hold and always park the vehicle by putting the transmission in Park (P) and applying the parking brake.

Auto Idle Stop*

Automatically stops and restarts the engine to help maximize fuel economy, depending on environmental and vehicle conditions.

■ Activating Auto Idle Stop

When the vehicle stops with the gear position in Drive (D) and the brake pedal is pressed, the engine turns off and the auto idle stop indicator appears.

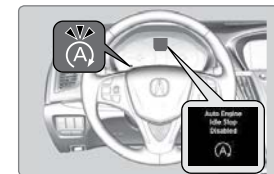

When you release the brake pedal, the engine restarts and the vehicle begins to move.

Auto idle stop does not activate (or the engine may automatically restart) when the driver's seat belt is unfastened, the vehicle is stopped on a steep hill, the windshield defroster is on, and other conditions. See the Owner's Manual on the Owner information CD or at owners.acura.com (U.S.) or myacura.ca (Canada) for a full list of conditions.

■ Turning the System On or Off

Press the Auto Idle Stop Off button to turn the system off. Press the button again to turn it on.



■ Climate Control Operation

When auto idle stop is activated, the air conditioning system is turned off.

The engine may restart automatically under the following conditions:

- You select MAX HEAT or MAX COOL on the climate control system.
- You turn on the windshield defroster.
- The interior humidity is high.
- There is a significant difference between the climate control set temperature and the actual interior temperature.

*if equipped

Integrated Dynamics System (IDS)

Choose a driving mode for your preference based on road conditions, vehicle speed, and handling.

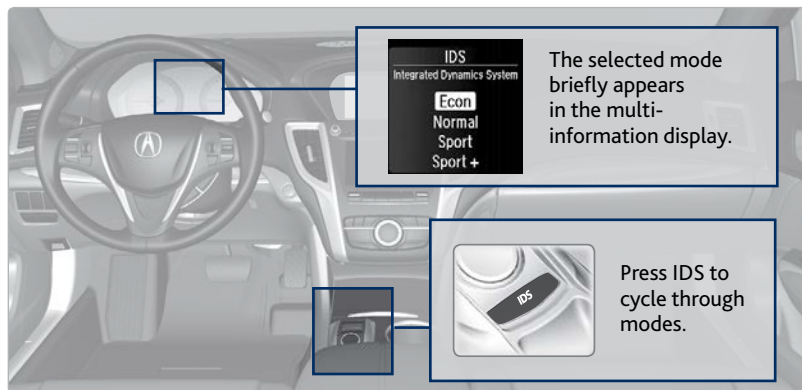

Econ: Maximizes fuel economy.

Normal: Balances fuel economy and sportiness for everyday driving.

Sport: Enhances vehicle response and feel through decreased steering assist and increased throttle response and SH-AWD* and Precision All-Wheel Steer™ (P-AWS®)* control.

Sport+: Adds to Sport mode and allows increased performance when using paddle shifters (see page 78 or 80).

Vehicle Stability Assist (VSA®), aka Electronic Stability Control (ESC) System

Helps to stabilize the vehicle during cornering if the vehicle turns more or less than what was intended. It assists in maintaining traction on slippery surfaces by regulating engine output and selectively applying the brakes.

Turning VSA On or Off

VSA is turned on every time you turn on the vehicle. If you turn VSA off, your vehicle has normal braking and cornering ability, but VSA traction and stability enhancement become less effective.

Press and hold the VSA OFF button until you hear a beep to turn VSA on or off. The VSA OFF indicator appears when the system is off.

Traction control stops functioning, which allows the wheels to spin more freely at low speed. This can be helpful when trying to free your vehicle if it is stuck in mud or snow.

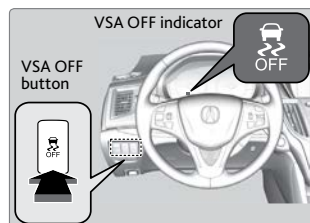

*if equipped

Cruise Control

Maintain a constant vehicle speed without having to keep your foot on the accelerator pedal. Use cruise control on freeways or open roads where you can travel at a constant speed with little acceleration or deceleration.

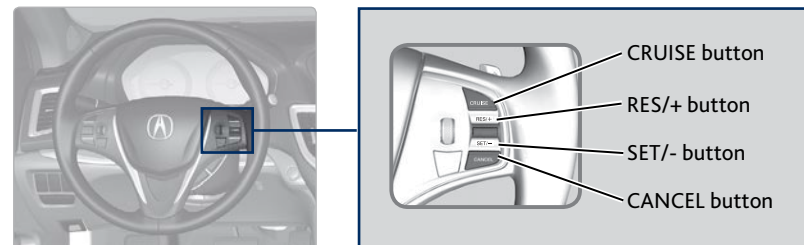

Setting the Vehicle Speed

1. Press CRUISE. The CRUISE MAIN indicator appears.
2. Accelerate to the desired speed (above 25 mph/40 km/h). Press SET/- and take your foot off the pedal to set the speed. The CRUISE CONTROL indicator appears.



Adjusting the Vehicle Speed

Press RES/+ to increase or SET/- to decrease speed.

Each time you press the button, the vehicle speed is increased or decreased by about 1 mph (1.6 km/h). If you keep the button pressed, the vehicle speed increases or decreases until you release it.



Canceling Cruise Control

Press CANCEL, CRUISE, or the brake pedal. The CRUISE CONTROL indicator goes off.

After cruise control has been canceled, you can still resume the prior set speed by pressing RES/+ while driving at a speed of at least 25 mph (40 km/h).

Press CRUISE to turn the system off.



WARNING

Improper use of the cruise control can lead to a crash.

Use cruise control only when traveling on open highways in good weather.

TABLE OF CONTENTS

VISUAL INDEX

SAFETY INFORMATION

INSTRUMENT PANEL

VEHICLE CONTROLS

AUDIO AND CONNECTIVITY

BLUETOOTH® HANDSFREELINK®

ACURALINK®

NAVIGATION

DRIVING

HANDLING THE UNEXPECTED

MAINTENANCE

SPECIFICATIONS

CLIENT INFORMATION

VOICE COMMAND INDEX

INDEX

Adaptive Cruise Control (ACC) with Low Speed Follow (LSF)*

Helps maintain a constant vehicle speed and a set following distance behind a vehicle detected ahead of yours. When the vehicle ahead changes speed, ACC senses the change and accelerates or decelerates to maintain a set interval.

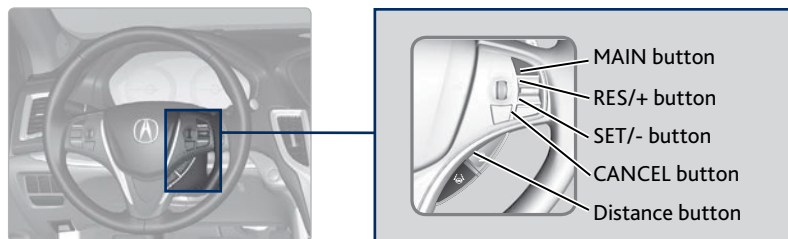

■ Activating and Setting the Vehicle Speed

1. Press MAIN. The ACC indicator appears.
2. Accelerate to the desired speed.
Above 25 mph (40 km/h): Press RES+/SET/- and take your foot off the pedal to set the speed
Below 25 mph (40 km/h) (Low Speed Follow): Press SET/- to set the speed at 25 mph (40 km/h) or below.



■ Adjusting the Vehicle Speed

Press RES/+ to increase or SET/- to decrease. Each time you press the switch up or down, the vehicle speed is increased or decreased by about 1 mph (1 km/h). If you keep the switch pressed up or down, the vehicle speed increases or decreases by 10 mph (16 km/h) until you release it.



■ Adjusting the Vehicle Distance

Press the Distance button to change the following distance. Each time you press the button, the following distance setting cycles through short, middle, long, and extra long following distances.



■ Switching to Standard Cruise Control

Press and hold the Distance button.

*if equipped

■ When in Operation

If a vehicle detected ahead of you slows down abruptly, or if another vehicle cuts in front of you, a beep sounds and BRAKE appears on the multi-information display to alert you.

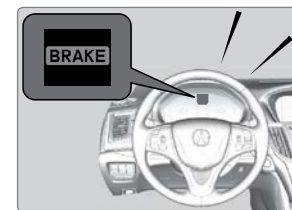

When a vehicle detected ahead is within ACC with low speed follow range and stops, your vehicle also stops. The Stopped message appears on the multi-information display.

When the vehicle ahead of you starts again, the vehicle icon on the multi-information display blinks. Press RES+/SET/- up or down, or press the accelerator pedal to resume the prior set speed.

⚠ WARNING

Exiting a vehicle that has been stopped while the ACC with LSF system is operating can result in the vehicle moving without operator control. Always make sure Park (P) is selected before exiting the vehicle.

A vehicle that moves without operator control can cause a crash, resulting in serious injury or death.

Never exit a vehicle when the vehicle is stopped by ACC with LSF.

⚠ WARNING

ACC with LSF has limited braking capability and may not stop your vehicle in time to avoid a collision with a vehicle that quickly stops in front of you.

Always be prepared to apply the brake pedal if the conditions require.

■ Canceling ACC

You can press CANCEL or MAIN, or press the brake pedal. The ACC indicator goes off.

Certain conditions may cause ACC to cancel automatically. When this happens, a beep sounds and a message appears on the multi-information display.



After cruise control has been canceled, you can still resume the prior set speed by pressing RES/ACCEL.

⚠ WARNING

Improper use of ACC with LSF can lead to a crash.

Use ACC with LSF only when driving on expressways or freeways and in good weather conditions.

Forward Collision Warning (FCW) with Pedestrian Detection*

Warns you if the system determines there is likelihood of a frontal collision when a vehicle is detected in front of you when your vehicle speed is 10 mph (16 km/h) or higher, or a pedestrian is detected in front of you when your vehicle speed is between 10–62 mph (16–100 km/h).

If you do not brake in time or take preventive action, a visual warning flashes*, BRAKE flashes in the MID, and a beep sounds continuously.

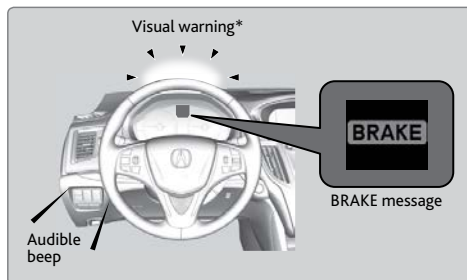

■ Changing Settings

Determine the warning timing, or turn the system off. Use the interface dial to make selections.

1. Press SETTINGS.
2. Select Vehicle Settings. The vehicle must be in Park (P).
3. Select Forward Collision Warning Distance.
4. Select Long, Normal (default), Short, or Off.
5. Press BACK to exit the menu.



Important Safety Reminder

FCW cannot detect all pedestrians and vehicles ahead; accuracy of the system will vary based on weather, speed, extreme interior heat, and other factors. FCW does not include a braking function. It is always your responsibility to safely operate the vehicle and avoid collisions.

Lane Departure Warning (LDW)*

A camera mounted between the windshield and the rearview mirror determines if your vehicle begins to move away from the center of a detected lane while driving between 45–90 mph (72–145 km/h).

If you cross a detected lane line without using the turn signal, a message appears in the MID and a beep sounds continuously.



■ Turning LDW On or Off

Press LDW to turn the system on or off. A green indicator light appears on the button when the system is on.

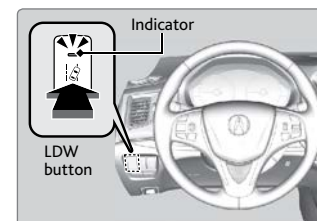

Important Safety Reminder

Like all assistance systems, LDW has limitations. Over-reliance on LDW may result in a collision. It is always your responsibility to keep the vehicle within your lane. LDW only alerts you when lane drift is detected without a turn signal in use. LDW may not detect all lane markings or lane departures; accuracy will vary based on weather, speed, and lane marker condition. It is always your responsibility to safely operate the vehicle and avoid collisions.

*if equipped

*if equipped

Lane Keeping Assist System (LKAS)*

A camera mounted between the windshield and the rearview mirror determines if your vehicle begins to move away from the center of a detected lane while driving between 45–90 mph (72–145 km/h).

If you cross a detected lane line without using your turn signal, a message appears on the MID and a beep sounds.

Light steering torque is applied to keep your vehicle in the middle of the lane.



Turning LKAS On or Off

1. Press MAIN. LKAS appears in the MID.



2. Press the LKAS button. Lane outlines appear in the MID. Dotted lane lines turn solid when the system operates.



3. Press MAIN or the LKAS button to turn the system off.



Important Safety Reminder

The LKAS is for your convenience only. It is not a substitute for your vehicle control. The system does not work if you take your hands off the steering wheel or fail to steer the vehicle.

Do not place an object on the top of the instrument panel. It may reflect onto the windshield and prevent the system from detecting lane lines properly.

*if equipped

Collision Mitigation Braking System™ (CMBS™)*

Can alert you when a potential frontal collision with a vehicle or pedestrian is determined and reduce your vehicle speed when a collision is deemed unavoidable to help minimize collision severity.

The system provides visual and audible alerts if you do not take appropriate action to avoid a collision.

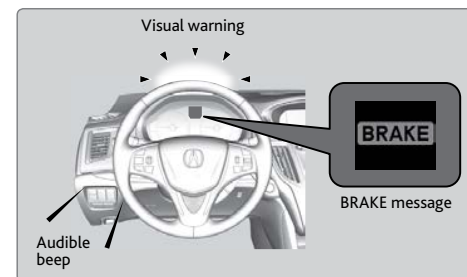

Alert Stages

The system has three alert stages for a possible collision. Depending on the circumstances or CMBS settings, CMBS may not go through all of the stages before initiating the last stage.

Stage 1: Visual warnings and audible warning

Stage 2: Visual warnings, audible warning, light seat belt retraction, and light brake application

Stage 3: Visual warnings, audible warning, strong seat belt retraction, and strong brake application

Turning CMBS On or Off

Press and hold the CMBS OFF button. A beep sounds and a message appears in the MID. The CMBS indicator appears when the system is off.

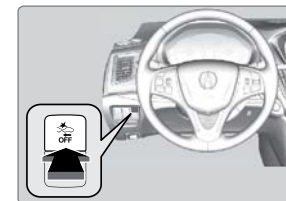

Changing Settings

See page 88 for how to change CMBS settings. Options include Long, Normal (default), and Short. Use the CMBS OFF button to turn the system off.

Important Safety Reminder

CMBS is designed to help avoid collisions by automatically stopping the vehicle when possible, and to reduce the severity of an unavoidable collision. It is still your responsibility to operate the brake pedal and steering wheel appropriately according to the driving conditions.

*if equipped

Road Departure Mitigation (RDM) System*

A camera mounted between the windshield and the rearview mirror determines if your vehicle begins to cross over detected lane markings while driving between 45–90 mph (72–145 km/h).

If you get too close to a detected lane line without using your turn signal, a message appears in the MID.

Steering wheel torque and vibrations are applied to help your vehicle stay in the lane. Braking may also be applied if the lane lines are solid and continuous.

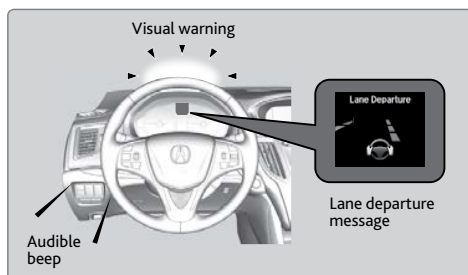

Turning the System On or Off

Press the RDM button to turn the system on or off. A green indicator appears on the button when the system is on.

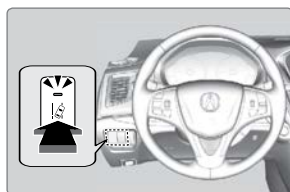

Changing Settings

Determine the warning timing, or turn the system off. Use the interface dial to make selections.

1. Press SETTINGS.
2. Select Vehicle Settings. The vehicle must be in Park (P).
3. Select Road Departure Mitigation System.
4. Select from the options.
 - Normal (default):* Steering control starts from inside the lane edge.
 - Wide:* Steering control starts from outside the lane edge.
 - Warning Only:* The system only provides a BRAKE message, but does not apply steering or braking.
5. Press BACK to exit the menu.



Important Safety Reminder

The system has limitations. Overreliance on it may result in a collision. It is always your responsibility to keep your vehicle within the driving lane.

*if equipped

Blind Spot Information (BSI) System*

Alerts you to a detected vehicle in your left or right blind spot.

When a vehicle is detected in your blind spot, the blind spot indicator turns on and stays lit until the area is clear.

When your turn signal is on and a vehicle is detected, the blind spot indicator blinks and a beep sounds until the area is clear or the turn signal is off.

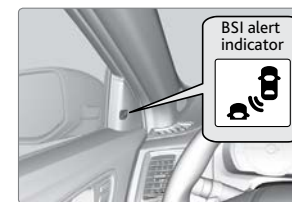

Changing BSI Settings

Change the alert type, or turn the system on or off. Use the interface dial to make selections.

1. Press SETTINGS.
2. Select Vehicle Settings. The vehicle must be in Park (P).
3. Select Blind Spot Info.
4. Select an alert type, or Off.
5. Press BACK to exit the menu.



WARNING

Failure to visually confirm that it is safe to change lanes before doing so may result in a crash and serious injury or death. Do not rely only on the blind spot information system when changing lanes.

Always look in your mirrors, to either side of your vehicle, and behind you for other vehicles before changing lanes.

Important Safety Reminder

Like all assistance systems, BSI has limitations. Over-reliance on BSI may result in a collision. The system is for your convenience only.

*if equipped

Parking Sensor System*

When the system senses an object when you are parking or backing up, an indicator appears on the upper display and a series of beeps will sound. As you get closer to the object, the beep rate increases.



Turning the System On or Off

Press the parking sensor button. A green indicator light appears on the button when the system is on.

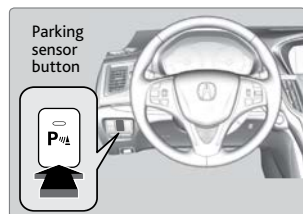

Super Handling-All Wheel Drive (SH-AWD)*

Controls and transfers varying amounts of engine torque to each wheel depending on driving conditions.

SH-AWD helps enhance stability in driving situations involving slippery surfaces, such as on wet, icy, or snowy roads. The system does not help enhance braking. It is still your responsibility to drive safely when you steer, accelerate, and apply brakes. Leave sufficient distance in front of you when braking on slippery surfaces.

NOTICE

Avoid continuously driving on slippery surfaces where a wheel is likely to spin out, and do not drive if the SH-AWD indicator starts blinking. Driving continuously under such conditions can damage the system's torque distribution unit.

*if equipped

Multi-View Rear Camera

When you shift into Reverse (R), a real-time image of the area behind your vehicle is shown in the display, along with helpful parking guidelines.

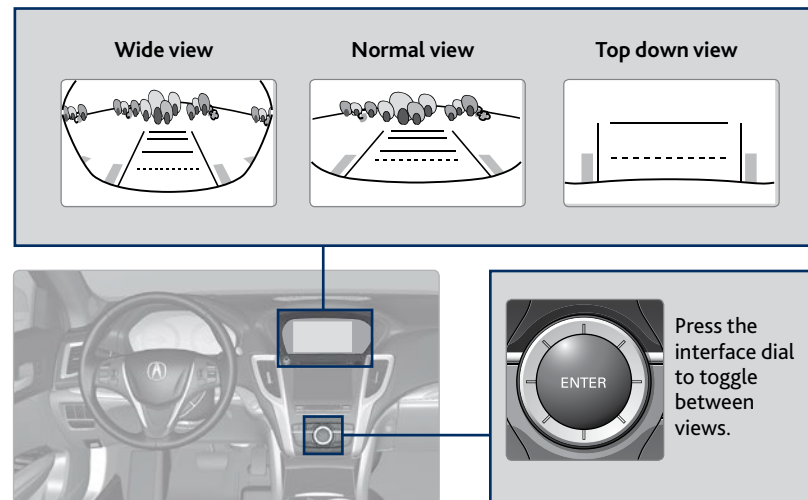

Changing Guidelines

1. Press SETTINGS.
2. Select Camera Settings.
3. Select Rear Camera.
4. Select one of the options.

Fixed Guideline: Guidelines appear when you shift into Reverse. Select On or Off.

Dynamic Guideline: Guidelines move as you turn the steering wheel. Select On or Off.

5. Press BACK to exit the menu.



The rear camera view is restricted. You cannot see the corner ends of the bumper or what is underneath the bumper. Its unique lens also makes objects appear closer or farther than they actually are.

Visually confirm that it is safe to drive before backing up. Certain conditions (such as weather, lighting, and high temperatures) may also restrict the rear view. Do not rely on the rearview display, which does not give you all information about conditions at the rear of your vehicle.

Rear Cross Traffic Monitor*

Alerts you if a detected vehicle is approaching from a rear corner when your vehicle is in Reverse (R) at speeds of 3 mph (5 km/h) or lower, which can be helpful when backing out of parking spaces.

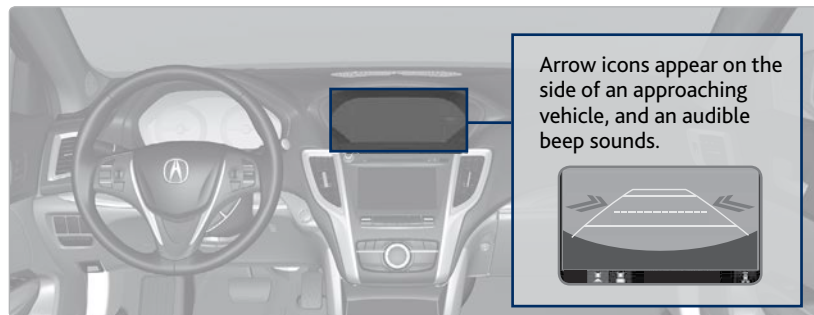

The system does not detect pedestrians, bicycles, or stationary objects.

Turning the System On or Off

1. Press SETTINGS.
2. Select Camera Settings.
3. Select Cross Traffic Monitor.
4. Select On or Off.
5. Press BACK to exit the menu.



CAUTION

This system is for your convenience only. The system cannot detect all approaching vehicles or avoid all possible collisions.

Failure to visually confirm that it is safe to reverse the vehicle before doing so may result in a collision. Do not rely only on the system's audible and visual alerts when reversing.

Always look in your mirrors, to either side of your vehicle, and behind you for other vehicles before reversing your vehicle.

*if equipped

Refueling

Use the proper fuel and refueling procedure to ensure the best performance and safety of your vehicle.

Fuel Information

Use of unleaded premium gasoline of 91 octane or higher is recommended.

- Acura recommends TOP TIER Detergent Gasoline where available.
- Do NOT use gasoline containing more than 15% ethanol.
- Do NOT use gasoline containing methanol.
- Do NOT use gasoline containing MMT.

NOTICE

We recommend quality gasoline containing detergent additives that help prevent fuel system and engine deposits. In addition, in order to maintain good performance, fuel economy, and emissions control, we strongly recommend the use of gasoline that does NOT contain harmful manganese-based fuel additives such as MMT, if such gasoline is available.

How to Refuel

Your fuel tank is not equipped with a fuel fill cap. You can insert the filler nozzle directly into the filler pipe. The tank seals itself again when you pull out the filler nozzle.

1. The fuel fill door is located at the left rear of the vehicle. Park next to the service pump that is most accessible, and turn off the engine.
2. Press the fuel fill door release button. The fuel fill door opens.
3. Place the end of the filler nozzle on the lower part of the filler opening, then insert it slowly and fully. Make sure that the end of the filler nozzle goes down along with the filler pipe.
4. After filling, wait about 5 seconds before removing the filler nozzle. Close the fuel fill door by hand.

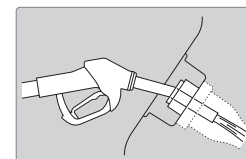
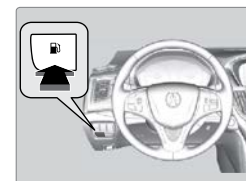

WARNING

Gasoline is highly flammable and explosive. You can be burned or seriously injured when handling fuel.

- Stop the engine, and keep heat, sparks, and flame away.
- Handle fuel only outdoors.
- Wipe up spills immediately.

HANDLING THE UNEXPECTED

Learn about what to do in critical or emergency situations.

Keyless Access Remote Battery Strength

If the battery life in your keyless access remote is weak, a message appears in the MID with information on how to start the engine.

1. Touch the back of the keyless access remote to the ENGINE START/STOP button while the indicator is flashing.
2. With the brake pedal pressed, press the ENGINE START/STOP button within 10 seconds.

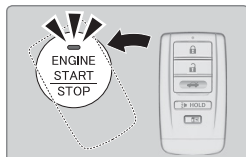

Shift Lever Does Not Move*

Follow the procedure below if you cannot move the shift lever out of Park (P).

1. Apply the parking brake.
2. Remove the built-in key from the remote transmitter.
3. Pull up the shift lock release cover to remove it.
4. Insert the key into the shift lock release slot.
5. While pushing the key into the slot, press the shift lever release button and shift into Neutral (N). The lock is now released. Have the shift lever checked by a dealer as soon as possible.

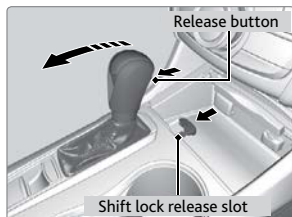
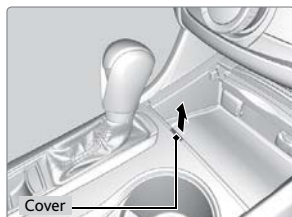

Jump Starting

Turn off the power to electric devices, such as audio and lights. Turn off the engine, then open the hood (see page 115).

1. **6-cylinder models:** Pull up on the engine cover, and remove it from the pins. Open the battery terminal cover.

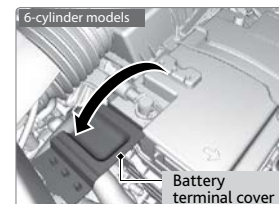
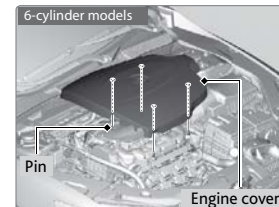

2. **All models:** Connect the first jumper cable to your vehicle's battery (+) terminal.

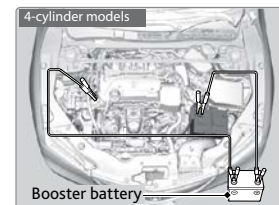

3. Connect the other end of the first jumper cable to the booster battery (+) terminal. Use a 12-volt booster battery only (i.e., an assisting vehicle or a rechargeable 12-volt battery pack).

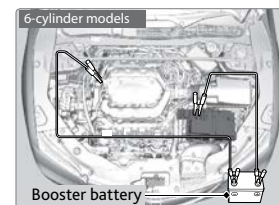

4. Connect the second jumper cable to the booster battery (-) terminal.

5. Connect the other end of the second jumper cable to the mounting bolt or engine hanger as shown. Do not connect this jumper cable to any other part.

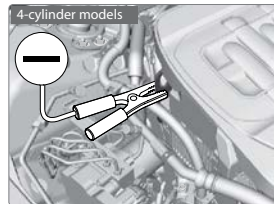

6. If your vehicle is connected to another vehicle, start the assisting vehicle's engine and increase its rpm slightly.

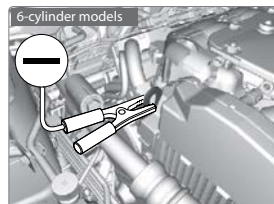

7. Attempt to start your vehicle's engine. If it turns over slowly, make sure the jumper cables have good metal-to-metal contact.

WARNING: Battery posts, terminals, and related accessories contain lead and lead compounds. **Wash your hands after handling.**

⚠️ WARNING

A battery can explode if you do not follow the correct procedure, seriously injuring anyone nearby.

Keep all sparks, open flames, and smoking materials away from the battery.

■ After the Engine Starts

Once your vehicle's engine has started, remove the jumper cables in the following order:

1. Disconnect the jumper cable from your vehicle's ground.
2. Disconnect the other end of the jumper cable from the booster battery (-) terminal.
3. Disconnect the jumper cable from your vehicle's battery (+) terminal.
4. Disconnect the other end of the jumper cable from the booster battery (+) terminal.

Have your vehicle inspected by a nearby service station or a dealer.

Overheating

If the temperature gauge needle is at the H mark, the engine suddenly loses power, or steam or spray comes out from under the hood, your engine is overheating.

1. Immediately park the vehicle in a safe place. Turn off all accessories and turn on the hazard warning lights.

2. **If no steam or spray is present:** Keep the engine running and open the hood (see page 115).

If steam or spray is present: Turn off the engine and wait until it subsides. Then, open the hood (see page 115).

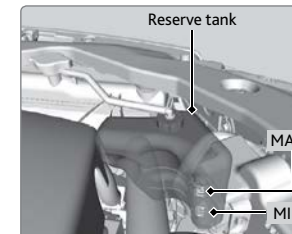

3. Check that the cooling fan is operating and stop the engine once the temperature gauge needle goes down. If the cooling fan is not operating, immediately stop the engine.

4. Once the engine has cooled down, inspect the coolant level and check the cooling system components for leaks. If the coolant level in the reserve tank is low, add coolant until it reaches the MAX mark. If there is no coolant in the reserve tank, make sure the radiator is cool, then cover the radiator cap with a heavy cloth and open the cap. If necessary, add coolant up to the base of the filler neck, and put the cap back on.

Once the engine has cooled sufficiently, restart it and check the temperature gauge. If the temperature needle has gone down, resume driving. If it has not gone down, contact a dealer for repairs.

⚠️ WARNING

Steam and spray from an overheated engine can seriously scald you.

Do not open the hood if steam is coming out.

⚠️ WARNING

Removing the radiator cap while the engine is hot can cause the coolant to spray out, seriously scalding you.

Always let the engine and radiator cool down before removing the radiator cap.

NOTICE

Continuing to drive with the temperature gauge needle at the H mark may damage the engine.

Emergency Engine Stop

The ENGINE START/STOP button may be used to stop the engine due to an emergency situation even while driving. If you must stop the engine, choose one of the following operations:

- Press and hold the ENGINE START/STOP button for two seconds, or
- Firmly press the ENGINE START/STOP button two times.

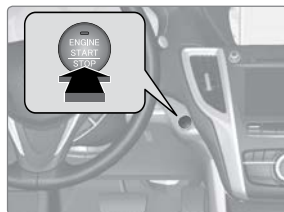

The steering wheel will not lock. The power mode changes to ACCESSORY, unless the shift lever is in Park, in which case the power mode changes to VEHICLE OFF.

Because turning off the engine also disables the power assist the engine provides to the steering and braking systems, it will require significantly more physical effort and time to steer and slow the vehicle. Downshift gears and use both feet on the brake pedal, if necessary, to slow the vehicle and stop immediately in a safe place.

NOTICE

Do not press the button while driving unless it is absolutely necessary for the engine to be switched off.

Emergency Towing

Call a professional towing service if you need to tow your vehicle.

All models

Flat bed equipment: The operator loads your vehicle on the back of a truck. **This is the best way to transport your vehicle.**

2WD models

Wheel lift equipment: The tow truck uses two pivoting arms that go under the front tires and lift them off the ground. The rear tires remain on the ground. **This is an acceptable way to tow your vehicle.**

NOTICE

Trying to lift or tow your vehicle by the bumpers will cause serious damage. The bumpers are not designed to support the vehicle's weight.

Improper towing such as towing behind a motorhome or other motor vehicle can damage the transmission.

Tire Pressure Monitoring System (TPMS)

Monitors the tire pressure while you are driving.

If your vehicle's tire pressure becomes significantly low, the low tire pressure indicator appears with a message in the multi-information display.

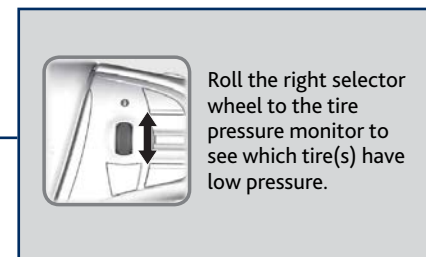
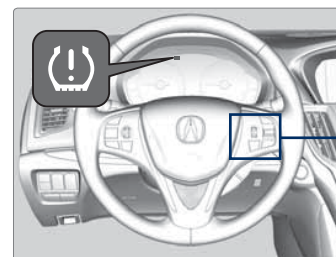

Roll the right selector wheel to the tire pressure monitor to see which tire(s) have low pressure.

■ Tire Fill Assist

Your vehicle gives you visual and audible alerts to help you adjust the tire pressure to its appropriate level. For your reference, the proper tire pressure levels are located on a label on the driver's doorjamb.

1. Stop your vehicle with the tire that needs to be filled nearest to a tire air fill hose. Shift into Park (P). Turn the vehicle off.
2. Turn the vehicle on. The assist system is activated for 5 minutes.
3. Attach the air hose to the valve stem, and begin to fill the tire.

While inflating: The system beeps and the hazard lights flash once every 5 seconds as tire pressure changes while below the correct pressure.

When the correct pressure is reached: The system beeps and the hazard lights flash continuously for 5 seconds. Stop filling the tire.

If you overinflate: The system beeps and the hazard lights flash twice every 5 seconds.

NOTICE

Driving on an extremely underinflated tire can cause it to overheat. An overheated tire can fail. Always inflate your tires to the specified pressure.

Tire Repair Kit*

If a tire has a small puncture, you can use the tire repair kit to temporarily repair it. The puncture must be smaller than 3/16-inch (4 mm) and not in the tire sidewall. Go to a dealer to have the full-size tire permanently repaired or replaced.

■ Before Repairing the Tire

1. Park the vehicle on firm, level, non-slippery surface.
2. Make sure the vehicle is in Park (P), and apply the electric parking brake.
3. Turn on the hazard warning lights, and turn the vehicle off.

■ Getting Ready to Repair the Tire

1. Open the trunk. Pull up the strap on the trunk floor lid, and open the lid.

If equipped, turn the knob on the tool case lid counterclockwise, and remove the cover.

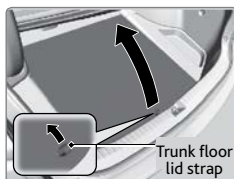

2. Remove the kit.

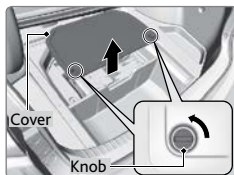

3. Place the kit face up on flat ground near the punctured tire and away from traffic. Do not place the kit on its side.



4. Follow the instructions in the kit to repair the tire.

NOTICE

Do not use a puncture-repairing agent other than the one provided in the kit that came with your vehicle. If a different agent is used, you may permanently damage the tire pressure sensor.

*if equipped

Changing a Flat Tire

If a tire goes flat while driving, grasp the steering wheel firmly, and brake gradually to reduce speed. Stop in a safe place. Replace the flat tire with the compact spare tire*. Go to a dealer as soon as possible to have the full-size tire repaired or replaced.

■ Before Changing the Tire

1. Park the vehicle on a firm, level, non-slippery surface.
2. Put the vehicle in Park (P), and apply the parking brake.
3. Turn on the hazard warning lights and turn the vehicle off.

■ Getting Ready to Change the Tire

1. Open the trunk. Open the trunk floor lid.

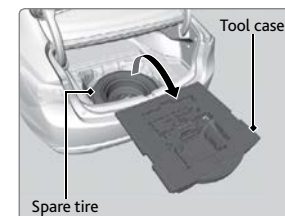

2. Take the tool case out of the trunk. Take the jack and wheel nut wrench out of the tool case.

3. Unscrew the wing bolt, and remove the spacer cone. Then, remove the spare tire.



4. Place the compact spare tire wheel side up under the vehicle body, near the tire that needs to be replaced.



5. Loosen each wheel nut about one turn using the wheel nut wrench.

*if equipped

■ Setting Up the Jack

1. Place the jack under the jacking point closest to the tire to be changed.

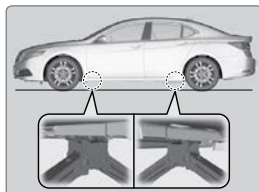

2. Turn the end bracket clockwise (as shown in the image) until the top of the jack contacts the jacking point. Make sure that the jacking point tab is resting in the jack notch. Do not overextend the jack.

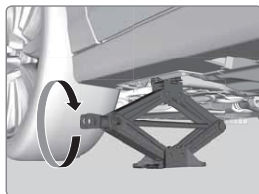

3. Raise the vehicle, using the jack handle bar and the jack handle, until the tire is off the ground.

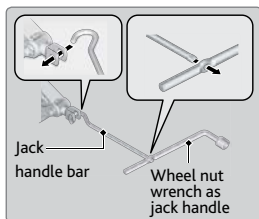

⚠ WARNING

The vehicle can easily roll off the jack, seriously injuring anyone underneath. Follow the directions for changing a tire exactly, and never get under the vehicle when it is supported only by the jack.

The following instructions must be followed to use the jack safely:

- Do not use the jack with people or luggage in the vehicle.
- Use the jack provided in your vehicle. Other jacks may not support the weight ("load") or fit the jacking point.
- Do not use while the engine is running.
- Use only where the ground is firm and level.
- Use only at the jacking points.
- Do not get in the vehicle while using the jack.
- Do not put anything on top of or underneath the jack.

NOTICE

Do not use the jack if it doesn't work properly. Call your dealer or a professional towing service.

■ Replacing the Flat Tire

1. Remove the wheel nuts and flat tire.
2. Mount the compact spare tire. Replace the wheel nuts, and lightly tighten them.
3. Lower the vehicle and remove the jack. Tighten the wheel nuts in the order indicated in the image. Go around, tightening the nuts, two to three times in this order. Do not over tighten the wheel nuts.

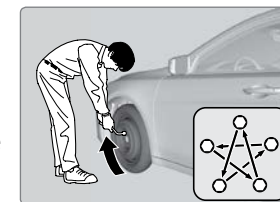
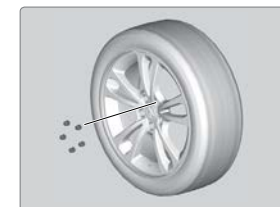

■ Storing the Flat Tire

1. Remove the center cap, and place the flat tire face down in the spare tire well.
2. Remove the spacer cone from the wing bolt, flip it over, and insert it back on to the bolt. Secure the flat tire with the wing bolt.
3. Return the jack and wheel nut wrench to the tool case. Store the case in the trunk, and close the trunk.

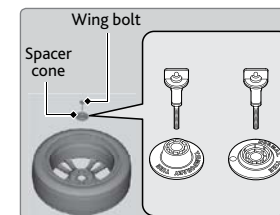

⚠ WARNING

Loose items can fly around the interior in a crash and can seriously injure the occupants.

Store the wheel, jack, and tools securely before driving.

Fuse Locations

If any electrical devices are not working, turn off the vehicle and check to see if any applicable fuse is blown. Fuse locations are shown on the fuse box cover. Locate the fuse by the fuse number and box cover number.

■ Engine Compartment Fuse Boxes

Located near the brake fluid reservoir. Push the tabs to open the box.

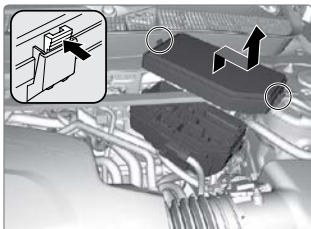

| | Circuit Protected | Amps |
|--------------|----------------------------|-------|
| 1 | EPS | 70 A |
| | Sub Fuse Box ^{*3} | 60 A |
| | ABS/VSA Motor | 40 A |
| | ABS/VSA FSR | 20 A |
| | Main Fan ^{*2, *3} | 30 A |
| | Main Fuse | 125 A |
| | IG Main | 30 A |
| 2 | F/B Main | 60 A |
| | F/B Main 2 | 60 A |
| | Headlight Main | 30 A |
| | IG Main 2 | 30 A |
| | Starter Cut 1 | 40 A |
| | Injector ^{*2, *3} | 20 A |
| | Sub Fan ^{*1} | 20 A |
| | Rear Defroster | 40 A |
| | Main Fan ^{*1} | 30 A |
| | Sub Fan ^{*2, *3} | 30 A |
| Wiper | 30 A | |
| Heater Motor | 40 A | |

| | Circuit Protected | Amps |
|----|------------------------------------|---------|
| 3 | Headlight Washer ^{*2, *3} | (30 A) |
| | Left Electric Parking Brake | 30 A |
| | Right Electric Parking Brake | 30 A |
| | SH-AWD ^{*3} | - |
| 4 | - | - |
| 5 | - | - |
| 6 | - | - |
| 7 | - | - |
| 8 | STRLD ^{*1, *2} | 7.5 A |
| 9 | Interior Lights ^{*1, *2} | 5 A |
| 10 | Headlight Low/High Main | 20 A |
| 11 | Oil Level | 7.5 A |
| 12 | Front Fog [*] | (7.5 A) |
| 13 | Passenger's Power Seat Reclining | 20 A |
| 14 | Hazard | 15 A |
| 15 | IGP2 | 15 A |
| 16 | IG Coil | 15 A |
| 17 | Stop ^{*1, *2} | 10 A |

*1: 4-cylinder models
 *2: 6-cylinder models with 2WD
 *3: 6-cylinder models with AWD

Located near the washer fluid cap. Push the tabs to open the box.

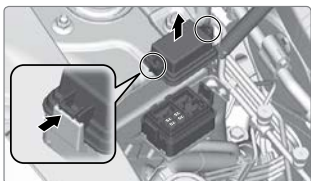

| | Circuit Protected | Amps |
|---|----------------------|-------|
| 1 | Headlight Low Left | 7.5 A |
| 2 | Headlight Low Right | 7.5 A |
| 3 | Headlight High Right | 7.5 A |
| 4 | Headlight High Left | 7.5 A |

**if equipped*

■ Driver's Side Interior Fuse Boxes

Located under the dashboard.

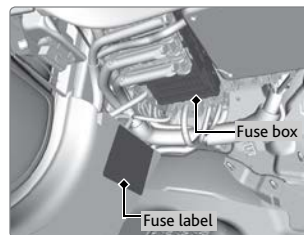

| | Circuit Protected | Amps |
|----|--|---------|
| 1 | A/C | 7.5 A |
| 2 | DRL | 7.5 A |
| 3 | ST Motor [*] | (7.5 A) |
| 4 | - | - |
| 5 | Meter ^{*1} Auto Dimming Mirror ^{*2} | 7.5 A |
| 6 | SRS | (7.5 A) |
| 7 | Option | 7.5 A |
| 8 | MISS SOL | (15 A) |
| 9 | Fuel Pump | 20 A |
| 10 | ABS/VSA ^{*1} Smart ^{*2} | (7.5 A) |
| 11 | Spare Fuse | 30 A |
| 12 | Wiper | 7.5 A |
| 13 | ACG | 15 A |
| 14 | Accessory Power Socket (Console Compartment) | 20 A |
| 15 | Driver's Power Seat Reclining | 20 A |
| 16 | Moonroof | 20 A |
| 17 | AVS/Seat Heaters | 20 A |
| 18 | - | - |
| 19 | Passenger's Side Door Unlock | 10 A |
| 20 | Driver's Side Rear Door Unlock | 10 A |
| 21 | Driver's Side Door Lock | (10 A) |
| 22 | Passenger's Side Door Lock | 10 A |
| 23 | Driver's Side Door Unlock | (10 A) |
| 24 | SRS | 10 A |
| 25 | Instrument Panel Lights | 7.5 A |
| 26 | ACC Key Lock | 7.5 A |

| | Circuit Protected | Amps |
|----|--|--------|
| 27 | Parking Lights | 7.5 A |
| 28 | Lumbar Support | 10 A |
| 29 | Right DRL | 7.5 A |
| 30 | Washer | 20 A |
| 31 | SMART | 10 A |
| 32 | Driver's Side Power Window | 20 A |
| 33 | Passenger's Side Power Window | 20 A |
| 34 | Rear Driver's Side Power Window | 20 A |
| 35 | Rear Passenger's Side Power Window | 20 A |
| 36 | Driver's Power Seat Sliding | 20 A |
| 37 | ACCESSORY | 7.5 A |
| 38 | - | - |
| 39 | Left DRL | 7.5 A |
| 40 | Accessory Power Socket (Center Pocket) | 20 A |
| 41 | Rear Driver's Side Door Lock | 10 A |
| 42 | Door Lock | 20 A |
| | Rear Seat Heater [*] | (15 A) |
| | Heated Steering Wheel [*] | (10 A) |

*1: 2WD models
 *2: AWD models

| | Circuit Protected | Amps |
|---|-------------------------------------|--------|
| A | - | - |
| B | - | - |
| C | Meter ^{*2} | 7.5 A |
| D | Back Up ^{*2} | 10 A |
| E | Stop ^{*2} | 7.5 A |
| F | Parking Lights ^{*2} | 15 A |
| G | Audio ACC ^{*2} | 7.5 A |
| | Rear Seat Heater ^{*2} | (15 A) |
| A | ABS/VSA ^{*2} | 7.5 A |
| B | MICU ^{*2} | 7.5 A |
| C | - | - |
| D | - | - |
| E | STRLD ^{*2} | 7.5 A |
| F | Audio ^{*2} | 20 A |
| G | ACM ^{*2} | 7.5 A |
| | Heated Steering Wheel ^{*2} | (10 A) |

*2: AWD models

Located inside the driver's side outer panel. Grasp the bottom edge of the panel and pull to remove it.

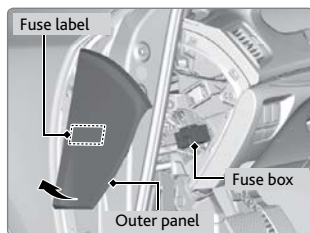

| | Circuit Protected | Amps |
|---|-------------------------|--------|
| 1 | P-AWS L | (40 A) |
| 2 | e-pretensioner Right* | (20 A) |
| 3 | e-pretensioner Left* | (20 A) |
| 4 | ACC Radar* | (10 A) |
| 5 | Idle Stop* ¹ | (30 A) |
| 6 | P-AWS R | (40 A) |
| 7 | FR DE-ICE* | (15 A) |
| 8 | Idle Stop* ¹ | (30 A) |

*1: AWD models

■ Inspecting and Changing Fuses

1. Turn off the vehicle, including the headlights and all accessories.
2. Remove the fuse box cover.
3. Check the large fuse in the engine compartment. If the fuse is blown, use a Phillips-head screwdriver to remove the screw and replace the fuse with a new one.
4. Inspect the small fuses in the engine compartment and the vehicle interior. If there is a burned out fuse, remove it with the fuse puller and replace it with a new one.

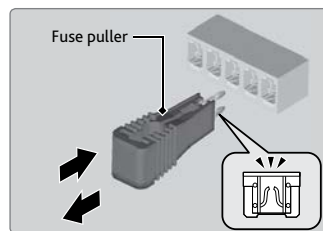
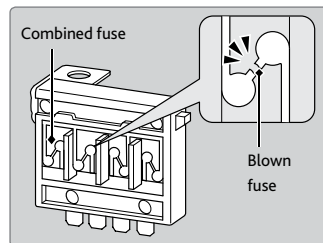

NOTICE

Replacing a fuse with one that has a higher rating greatly increases the chances of damaging the electrical system.

*if equipped

MAINTENANCE

Learn about basic maintenance that you can perform on the vehicle yourself, as well as information about how to best maintain the vehicle.

Safety Precautions

Some of the most important safety precautions are listed below; however, we cannot warn you of every conceivable hazard that can arise in performing maintenance. Only you can decide whether or not you should perform a given task.

■ Maintenance Safety

- To reduce the possibility of fire or explosion, keep cigarettes, sparks, and flames away from the battery and all fuel-related parts.
- Never leave rags, towels, or other flammable objects under the hood.
- To clean parts, use a commercially available degreaser or parts cleaner, not gasoline.
- Wear eye protection and protective clothing when working with the battery or compressed air.
- Do not run the engine in confined spaces where carbon monoxide gas can accumulate.

■ Vehicle Safety

- The vehicle must be in a stationary condition, and parked on level ground with the parking brake set and the engine off.
- Be aware that hot parts can burn you.
- Be aware that moving parts can injure you.
- Do not open the hood during auto idle stop operation* (see page 83).

⚠ WARNING

Improperly maintaining this vehicle or failing to correct a problem before driving can cause a crash in which you can be seriously hurt or killed.

Always follow the inspection and maintenance recommendations according to the schedules in this guide.

⚠ WARNING

Failure to properly follow maintenance instructions and precautions can cause you to be seriously hurt or killed.

Always follow the procedures and precautions in this guide.

*if equipped

Maintenance Minder™

Reminds you when indicated maintenance service is due.

When maintenance is due, the system message indicator comes on and the Maintenance Minder appears on the multi-information display every time you turn the vehicle on.

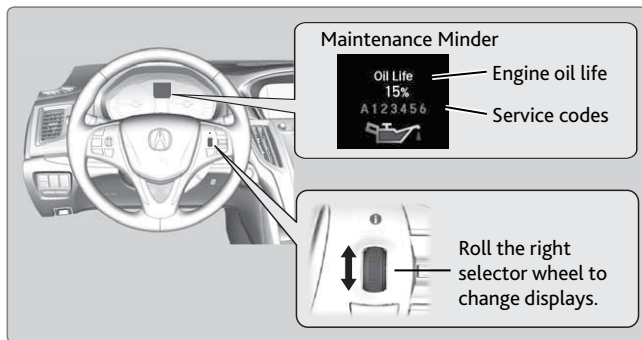

- Independent of the Maintenance Minder information, replace the brake fluid every 3 years.
- Inspect idle speed every 160,000 miles (256,000 km).
- Adjust the valves during services A, B, 1, 2, or 3 if they are noisy.

Maintenance Minder Service Codes

These codes indicate what services are due on your vehicle.

| CODE | Maintenance Main Items |
|------|---|
| A | <ul style="list-style-type: none"> • Replace engine oil*1 |
| B | <ul style="list-style-type: none"> • Replace engine oil*1 and oil filter • Inspect front and rear brakes • Inspect tie rod ends, steering gearbox, and boots • Inspect suspension components • Inspect driveshaft boots • Inspect brake hoses and lines (Including ABS/VSA) • Inspect all fluid levels and condition of fluids • Inspect exhaust system# • Inspect fuel lines and connections # <p>Check expiration information for Temporary Tire Repair Kit bottle</p> |

| CODE | Maintenance Sub Items |
|------|--|
| 1 | <ul style="list-style-type: none"> • Rotate tires |
| 2 | <ul style="list-style-type: none"> • Replace air cleaner element*2 • Replace dust and pollen filter*3 • Inspect drive belt |
| 3 | <ul style="list-style-type: none"> • Replace transmission fluid*4 |
| 4 | <ul style="list-style-type: none"> • Replace spark plugs • Replace timing belt and inspect water pump*5, *6 • Inspect valve clearance |
| 5 | <ul style="list-style-type: none"> • Replace engine coolant |
| 6 | <ul style="list-style-type: none"> • Replace rear differential fluid*, *7 |

*1: If a message Maintenance Due Now/SERVICE DUE NOW does not appear more than 12 months after the display is reset, change the engine oil every year.
 #: See information on maintenance and emissions warranty.
 *2: If you drive in dusty conditions, replace the air cleaner element every 15,000 miles (24,000 km).
 *3: If you drive primarily in urban areas that have high concentrations of soot in the air from industry and from diesel-powered vehicles, replace the dust and pollen filter every 15,000 miles (24,000 km).
 *4: Driving in mountainous areas at very low vehicle speeds results in higher transmission temperature. This requires transmission fluid changes more frequently than recommended by the Maintenance Minder. If you regularly drive your vehicle under these conditions, have the transmission fluid changed at 40,000 miles (64,000 km), then every 30,000 miles (48,000 km).
 *5: If you drive regularly in very high temperatures (over 110°F, 43°C), in very low temperatures (under -20°F, -29°C), replace every 60,000 miles/100,000 km.
 *6: 6-cylinder models
 *7: Driving in mountainous areas at very low vehicle speeds results in higher level of mechanical (shear) stress to fluid. This requires differential fluid changes more frequently than recommended by the Maintenance Minder. If you regularly drive your vehicle under these conditions, have the differential fluid changed at 7,500 miles (12,000 km), then every 15,000 miles (24,000 km).

U.S. Models

Maintenance, replacement, or repair of emissions control devices and systems may be done by any automotive repair establishment or individuals using parts that are certified to EPA standards.

According to state and federal regulations, failure to perform maintenance on the maintenance main items marked with # will not void your emissions warranties. However, all maintenance services should be performed in accordance with the intervals indicated by the multi-information display.

TABLE OF CONTENTS

VISUAL INDEX

SAFETY INFORMATION

INSTRUMENT PANEL

VEHICLE CONTROLS

AUDIO AND CONNECTIVITY

BLUETOOTH® HANDSFREELINK®

ACURALINK®

NAVIGATION

DRIVING

HANDLING THE UNEXPECTED

MAINTENANCE

SPECIFICATIONS

CLIENT INFORMATION

VOICE COMMAND INDEX

INDEX

Under the Hood

4-cylinder models

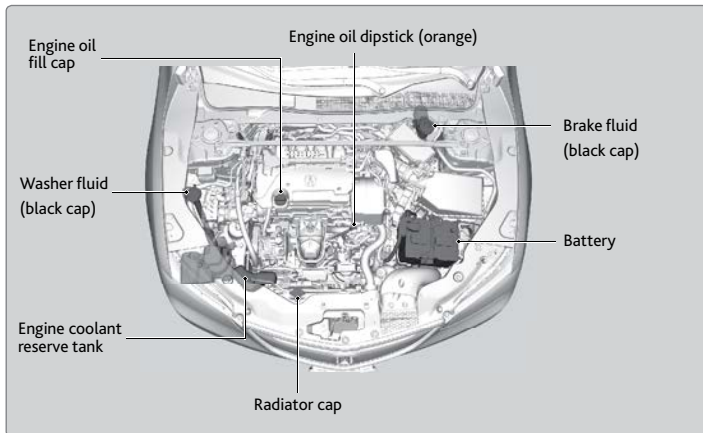

6-cylinder models

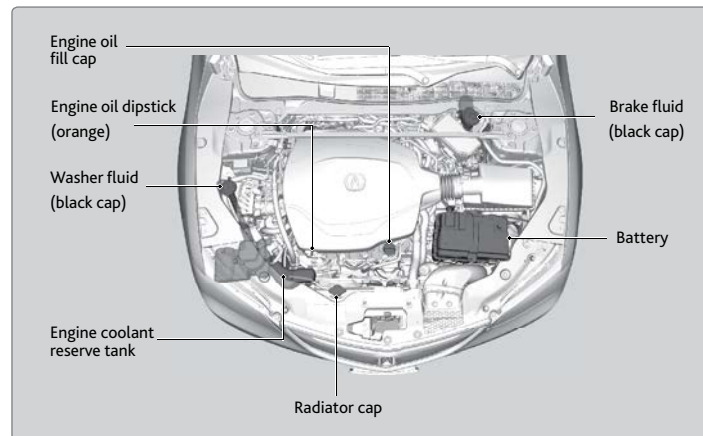

Opening the Hood

1. Park the vehicle on a level surface, and apply the electric parking brake.
2. Pull the hood release handle under the lower left corner of the dashboard.
3. Slide the hood latch lever in the center of the hood to release the lock mechanism. Open the hood.
4. Lift the hood up most of the way. The hydraulic supports lift it up the rest of the way and hold it up.

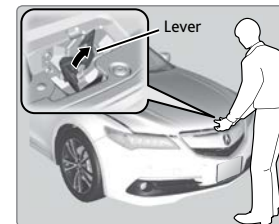
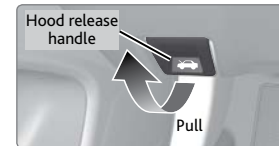

When closing the hood, lower it to approximately 12 inches (30 cm), then press firmly down with your hands.

NOTICE

Do not open the hood when the wiper arms are raised. The hood will strike the wipers, and may damage either the hood or the wipers.

Do not open the hood during auto idle stop operation* (see page 83).

*if equipped

Engine Oil

Park the vehicle on level ground, and wait approximately three minutes after turning the engine off before you check the oil.

■ Checking the Oil

1. Open the hood (see page 115). Remove the dipstick (orange loop).
2. Wipe the dipstick with a clean cloth or paper towel.
3. Insert the dipstick all the way back into its hole.
4. Remove the dipstick again, and check the level. It should be between the upper and lower marks. Add oil if necessary.

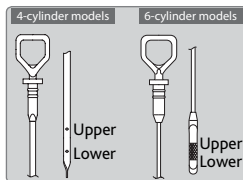
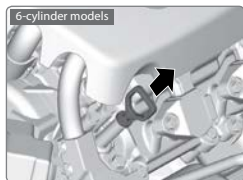
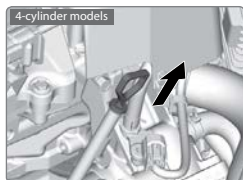

■ Recommended Engine Oil

- Genuine Acura Motor Oil
- Premium-grade 0W-20 detergent oil with an API Certification Seal on the container

This seal indicates the oil is energy conserving and that it meets the American Petroleum Institute's latest requirements.



Use Genuine Acura Motor Oil or another commercial engine oil of suitable viscosity for the ambient temperature as shown.

You may also use synthetic motor oil if it is labeled with the API Certification Seal and is of the specified viscosity grade.

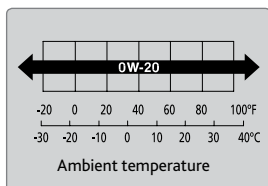

■ Adding Oil

1. Unscrew and remove the engine oil fill cap.
2. Add oil slowly.
3. Reinstall the engine oil fill cap, and tighten it securely.
4. Wait for three minutes and recheck the engine oil dipstick.

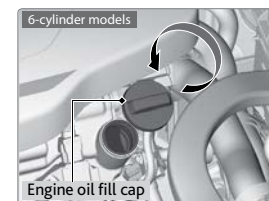
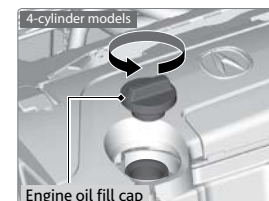

NOTICE

Do not fill the engine oil above the upper mark. Overfilling the engine oil can result in leaks and engine damage.

■ Resetting the Engine Oil Life

If you change or replace the vehicle's engine oil yourself, you must reset the engine oil life. Use the right selector wheel on the steering wheel to make selections in the MID.

1. Scroll to Maintenance Info and select it to display the oil life reset mode.
2. Select Reset. The service code disappears and the oil life returns to 100%.



NOTICE

Failure to reset the engine oil life after a maintenance service results in the system showing incorrect maintenance intervals, which can lead to serious mechanical problems.

Engine Coolant

Park the vehicle on level ground. Check the reserve tank and the coolant level in the radiator. **We recommend Acura Long Life Antifreeze/Coolant Type 2.**

■ Checking the Reserve Tank

1. Open the hood (see page 115). Check the amount of coolant in the reserve tank.
2. If the coolant level is below the MIN mark, add the specified coolant until it reaches the MAX mark.
3. Inspect the cooling system for leaks.

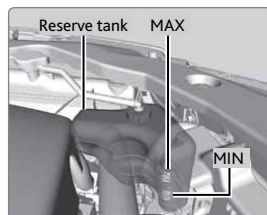

NOTICE

If temperatures consistently below -22°F (-30°C) are expected, the coolant mixture should be changed to a higher concentration. Consult a dealer for more information.

■ Adding Coolant

1. Make sure the engine and radiator are cool.
2. Turn the radiator cap counterclockwise and relieve any pressure in the coolant system. Do not push the cap down when turning.
3. Push down and turn the radiator cap counterclockwise to remove it.
4. The coolant level should be up to the base of the filler neck. Add coolant if it is low.
5. Put the radiator cap back on, and tighten it fully.
6. Pour coolant into the reserve tank until it reaches the MAX mark. Put the cap back on the reserve tank.

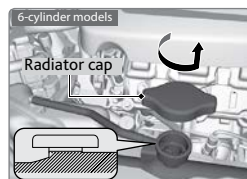
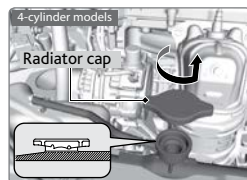

⚠ WARNING

Removing the radiator cap while the engine is hot can cause the coolant to spray out, seriously scalding you.
Always let the engine and radiator cool down before removing the radiator cap.

NOTICE

Pour the fluid slowly and carefully so you do not spill any. Clean up any spills immediately; they can damage components in the engine compartment.

Window Washer Fluid

Check the amount of window washer fluid by looking at the reservoir. Fill if it is low. Pour the washer fluid carefully. Do not overflow the reservoir

Canadian models

If the washer fluid is low, a message appears on the multi-information display.

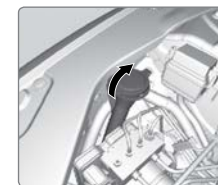

NOTICE

Do not use engine antifreeze or a vinegar/water solution in the windshield washer reservoir. Antifreeze can damage your vehicle's paint. A vinegar/water solution can damage the windshield washer pump.

Checking the Battery

The battery condition is monitored by the sensor on the negative terminal. If there is a problem with the sensor, a message appears on multi-information display. Have your vehicle checked by a dealer.

For jump starting the battery, see page 99.

⚠ WARNING

The battery gives off explosive hydrogen gas during normal operation. A spark or flame can cause the battery to explode with enough force to kill or seriously hurt you.
When conducting any battery maintenance, wear protective clothing and a face shield, or have a skilled technician do it.

WARNING: Battery posts, terminals, and related accessories contain lead and lead compounds. **Wash your hands after handling.**

Changing Wiper Blades

If the wiper blades leave streaks across the windshield, try cleaning them first with a paper towel or soft cloth and wiper fluid. If the wiper blade rubber has deteriorated, you should change the wiper blades.

1. Lift the driver side wiper arm first, then the passenger side.
2. Press and hold the tab, then slide the blade out from the wiper arm.
3. Pull the end of the wiper blade to the direction of the arrow (shown in the image) until it unfastens from the holder's end cap.
4. Pull the wiper blade to the opposite direction to slide it out from its holder.
5. Insert the flat side of the new wiper blade onto the bottom part of the holder. Insert the blade all the way.
6. Install the end of the wiper blade into the end cap.
7. Slide the wiper blade onto the wiper arm until it locks.
8. Lower the passenger side wiper arm first, then the driver side.

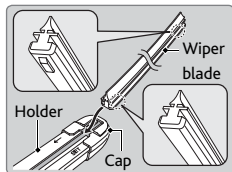
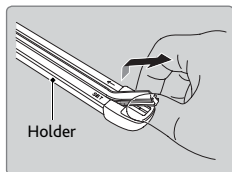
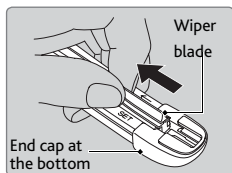
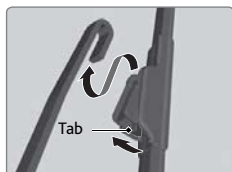
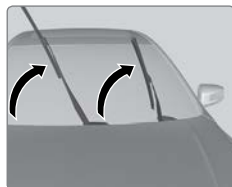

NOTICE

Avoid dropping the wiper arm, as it may damage the windshield.

Tire Information

To safely operate your vehicle, your tires must be of the proper type and size, in good condition with adequate tread, and properly inflated.

■ Inflation Guidelines

- Properly inflated tires provide the best combination of handling, tread life, and comfort. Refer to the driver's doorjamb label or the specifications (see page 129) for the specified pressure.
- Underinflated tires wear unevenly, adversely affect handling and fuel economy, and are more likely to fail from overheating.
- Overinflated tires make your vehicle ride harshly, are more prone to road hazards, and wear unevenly.
- Every day before you drive, look at each of the tires. If one looks lower than the others, check the pressure with a tire gauge.
- Measure the air pressure when tires are cold. This means the vehicle has been parked for at least 3 hours, or driven less than 1 mile (1.6 km). If necessary, add or release air until the specified pressure is reached. If checked when hot, tire pressure can be as much as 4-6 psi (30-40 kPa, 0.3-0.5 kgf/cm²) higher than checked when cold.
- At least once a month or before long trips, use a gauge to measure the pressure in all tires, including the spare. Even tires in good condition can lose 1-2 psi (10-20 kPa, 0.1-0.2 kgf/cm²) per month.

■ Inspection Guidelines

Every time you inflate the tires, check for the following:

- Any damage to tires, including bumps, bulges, cuts, splits, or cracks in the side or tread. Remove any foreign objects and inspect for air leaks. Replace tires if you see fabric or cord.
- Uneven or excessive tread wear. Have a dealer check the wheel alignment.
- Cracks or other damage around the valve stems.

■ Wear Indicators

The groove where the wear indicator is located is 1/16 inch (1.6 mm) shallower than elsewhere on the tire. If the tread has worn so low that the indicator is exposed, replace the tire. **Worn out tires have poor traction on wet roads.**

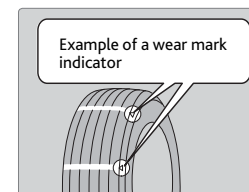

TABLE OF CONTENTS

VISUAL INDEX

SAFETY INFORMATION

INSTRUMENT PANEL

VEHICLE CONTROLS

AUDIO AND CONNECTIVITY

BLUETOOTH® HANDSFREELINK®

ACURALINK®

NAVIGATION

DRIVING

HANDLING THE UNEXPECTED

MAINTENANCE

SPECIFICATIONS

CLIENT INFORMATION

VOICE COMMAND INDEX

INDEX

⚠️WARNING

Using tires that are excessively worn or improperly inflated can cause a crash in which you can be seriously hurt or killed.

Follow all instructions in this owner's manual regarding tire inflation and maintenance.

■ Tire and Loading Information Label

The label attached to the driver's doorjamb provides necessary tire and loading information.

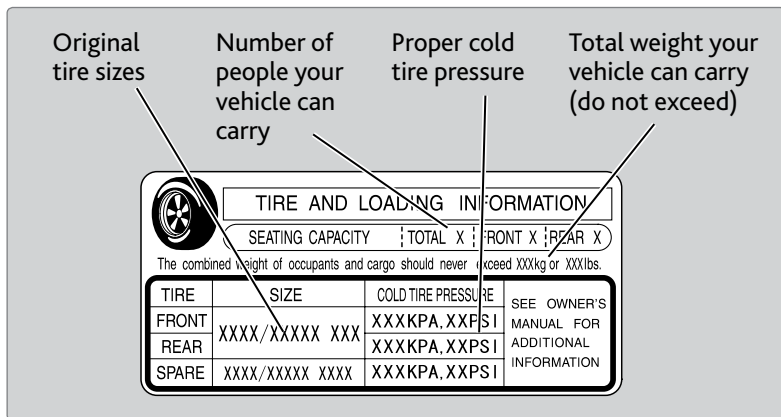

■ Tire and Wheel Replacement

Replace your tires with radials of the same size, load range, speed rating, and maximum cold tire pressure rating (as shown on the tire's sidewall). Using tires of a different size or construction can cause certain vehicle systems to work incorrectly. It is best to replace all four tires at the same time. If that isn't possible, replace the front or rear tires in pairs.

If you change or replace a wheel, make sure that the wheel's specifications match those of the original wheels. Only use TPMS-specified wheels approved for your vehicle.

⚠️WARNING

Installing improper tires on your vehicle can affect handling and stability. This can cause a crash in which you can be seriously hurt or killed.

Always use the size and type of tires recommended in the Owner's Manual.

■ Tire Service Life

The life of your tires is dependent on many factors, including driving habits, road conditions, vehicle loading, inflation pressure, maintenance history, speed, and environmental conditions (even when the tires are not in use).

In addition to regular inspections and inflation pressure maintenance, it is recommended that you have annual inspections performed once the tires reach five years old. All tires, including the spare, should be removed from service after 10 years from the date of manufacture, regardless of their condition or state of wear.

■ Winter Tires

If driving on snowy or frozen roads, mount all season tires marked "M+S", snow tires, or tire chains; reduce speed; and maintain sufficient distance between vehicles when driving. For winter tires, select the size and load ranges that are the same as the original tires, and mount them to all four wheels.

■ Tire Chains

Install tire chains on the front tires only. Because your vehicle has limited tire clearance, we strongly recommend using the following chains: **Cable type: QCC Premium Cobra 1042P with tensioner.** Mount chains as tightly as you can, and make sure that they do not touch the brake lines or suspension.

NOTICE

Traction devices that are the wrong size or improperly installed can damage your vehicle's brake lines, suspension, body, and wheels. Stop driving if they are hitting any part of the vehicle.

⚠️WARNING

Using the wrong chains, or not properly installing chains, can damage the brake lines and cause a crash in which you can be seriously injured or killed.

Follow all instructions in this guide regarding the selection and use of tire chains.

TABLE OF CONTENTS

VISUAL INDEX

SAFETY INFORMATION

INSTRUMENT PANEL

VEHICLE CONTROLS

AUDIO AND CONNECTIVITY

BLUETOOTH® HANDSFREELINK®

ACURALINK®

NAVIGATION

DRIVING

HANDLING THE UNEXPECTED

MAINTENANCE

SPECIFICATIONS

CLIENT INFORMATION

VOICE COMMAND INDEX

INDEX

Tire Labeling

The tires that came on your vehicle have a number of markings. Those you should be aware of are described below.

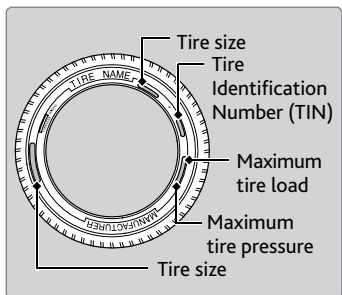

Here is an example of what each marking means:

215/70R16 100S

- 215: tire width in millimeters
- 70: aspect ratio (tire section height as a percentage of its width)
- R: tire construction code (radial)
- 16: rim diameter in inches
- 100: load index (code indicating maximum load tire can carry)
- S: speed symbol (code indicating maximum speed rating)

■ Tire Identification Number (TIN)

The tire identification number (TIN) is a group of numbers and letters that look like the example below. TIN is located on the sidewall of the tire.

DOT B97R FW6X 2209
 DOT: This indicates that the tire meets all requirements of the U.S. Department of Transportation.
 B97R: Manufacturer's identification mark.
 FW6X: Tire type code.
 22 09: Date of manufacture.

— Year
 — Week

■ Glossary of Tire Terminology

Cold Tire Pressure – The tire air pressure when the vehicle has been parked for at least three hours or driven less than 1 mile (1.6 km).

Load Rating – The maximum load that a tire is rated to carry for a given inflation pressure.

Maximum Inflation Pressure – The maximum tire air pressure that the tire can hold.

Maximum Load Rating – The load rating for a tire at the maximum permissible inflation pressure for that tire.

Recommended Inflation Pressure – The cold tire inflation pressure recommended by the manufacturer.

Treadwear Indicators (TWI) – The projections within the principal grooves designed to give a visual indication of the degrees of wear of the tread.

DOT Tire Quality Grading

The tires on your vehicle meet all U.S. Federal Safety Requirements. All tires are also graded for treadwear, traction, and temperature performance according to Department of Transportation (DOT) standards. The following explains these gradings.

■ Uniform Tire Quality Grading

Quality grades can be found where applicable on the tire sidewall between tread shoulder and maximum section width.

For example:

Treadwear 200
Traction AA
Temperature A

All passenger car tires must conform to Federal Safety Requirements in addition to these grades.

■ Treadwear

The treadwear grade is a comparative rating based on the wear rate of the tire when tested under controlled conditions on a specified government test course. For example, a tire graded 150 would wear one and one-half (1 1/2) times as well on the government course as a tire graded 100. The relative performance of tires depends upon the actual conditions of their use, however, and may depart significantly from the norm due to variations in driving habits, service practices, and differences in road characteristics and climate.

■ Traction

The traction grades, from highest to lowest, are AA, A, B, and C. Those grades represent the tire's ability to stop on wet pavement as measured under controlled conditions on specified government test surfaces of asphalt and concrete. A tire marked C may have poor traction performance.

WARNING: The traction grade assigned to this tire is based on straight-ahead braking traction tests, and does not include acceleration, cornering, hydroplaning, or peak traction characteristics.

■ Temperature

The temperature grades are A (the highest), B, and C, representing the tire's resistance to the generation of heat and its ability to dissipate heat when tested under controlled conditions on a specified indoor laboratory test wheel. Sustained high temperature can cause the material of the tire to degenerate and reduce tire life, and excessive temperature can lead to sudden tire failure. The grade C corresponds to a level of performance which all passenger car tires must meet under the Federal Motor Vehicle Safety Standard No. 109. Grades B and A represent higher levels of performance on the laboratory test wheel than the minimum required by law.

WARNING: The temperature grade for this tire is established for a tire that is properly inflated and not overloaded. Excessive speed, underinflation, or excessive loading, either separately or in combination, can cause heat buildup and possible tire failure.

Tire Pressure Monitoring System (TPMS) - Required Federal Explanation

Each tire, including the spare (if provided), should be checked monthly when cold and inflated to the inflation pressure recommended by the vehicle manufacturer on the vehicle placard or tire inflation pressure label. (If your vehicle has tires of a different size than the size indicated on the vehicle placard or tire inflation pressure label, you should determine the proper tire inflation pressure for those tires.)

As an added safety feature, your vehicle has been equipped with a tire pressure monitoring system (TPMS) that illuminates a low tire pressure telltale when one or more of your tires is significantly under-inflated.



Accordingly, when the low tire pressure telltale illuminates, you should stop and check your tires as soon as possible, and inflate them to the proper pressure.

Driving on a significantly under-inflated tire causes the tire to overheat and can lead to tire failure. Under-inflation also reduces fuel efficiency and tire tread life, and may affect the vehicle's handling and stopping ability.

Please note that the TPMS is not a substitute for proper tire maintenance, and it is the driver's responsibility to maintain correct tire pressure, even if under-inflation has not reached the level to trigger illumination of the TPMS low tire pressure telltale.

Your vehicle has also been equipped with a TPMS malfunction indicator to indicate when the system is not operating properly. The TPMS malfunction indicator is combined with the low tire pressure telltale. When the system detects a malfunction, the telltale will flash for approximately one minute and then remain continuously illuminated. This sequence will continue upon subsequent vehicle start-ups as long as the malfunction exists.

When the malfunction indicator is illuminated, the system may not be able to detect or signal low tire pressure as intended.

TPMS malfunctions may occur for a variety of reasons, including the installation of replacement or alternate tires or wheels on the vehicle that prevent the TPMS from functioning properly.

Always check the TPMS malfunction telltale after replacing one or more tires or wheels on your vehicle to ensure that the replacement or alternate tires and wheels allow the TPMS to continue to function properly.

TABLE OF CONTENTS

VISUAL INDEX

SAFETY INFORMATION

INSTRUMENT PANEL

VEHICLE CONTROLS

AUDIO AND CONNECTIVITY

BLUETOOTH® HANDSFREELINK®

ACURALINK®

NAVIGATION

DRIVING

HANDLING THE UNEXPECTED

MAINTENANCE

SPECIFICATIONS

CLIENT INFORMATION

VOICE COMMAND INDEX

INDEX

Testing of Readiness Codes

Your vehicle has “Readiness Codes” as part of the onboard self-diagnostic system. Some states refer to these codes as a test to see if your vehicle’s emissions components are working properly. The codes may not be read if you go through the testing just after the battery has gone dead or been disconnected.

To check if they are set, set the power mode to ON without starting the engine. The malfunction indicator lamp will come on for several seconds. If it goes off, the readiness codes are set. If it blinks five times, the readiness codes are not set.

If you are required to have your vehicle tested before the readiness codes are set, prepare the vehicle for retesting by doing the following:

1. Fill the gas tank to approximately 3/4 full.
2. Park the vehicle and leave the engine off for 6 hours or more.
3. Make sure the ambient temperature is between 40°F and 95°F (4°C and 35°C).
4. Start the engine without touching the accelerator pedal, and let it idle for 20 seconds.
5. Keep the vehicle in Park. Increase the engine speed to 2,000 rpm, and hold it there for about 3 minutes.
6. Let the engine idle with your foot off the accelerator for 20 seconds.
7. Select a nearby, lightly traveled major highway where you can maintain a speed of 50 to 60 mph (80 to 97 km/h) for at least 20 minutes. Drive on the highway with the vehicle in Drive. Do not use cruise control. When traffic allows, drive for 90 seconds without using the accelerator pedal. (Vehicle speed may vary slightly; this is OK.) If you cannot do this for a continuous 90 seconds because of traffic conditions, drive for at least 30 seconds, then repeat two more times (for a total of 90 seconds).
8. Drive in city/suburban traffic for at least 10 minutes. When traffic conditions allow, let the vehicle coast for several seconds without using the accelerator pedal or the brake pedal.
9. Park the vehicle and leave the engine off for 30 minutes.

The readiness codes are erased when the battery is disconnected, and set again only after several days of driving under a variety of conditions.

If a testing facility determines that the readiness codes are not set, you may be requested to return at a later date to complete the test, or see your dealer.

SPECIFICATIONS

4-cylinder models

Vehicle

| | | |
|----------------------------------|------------------------------|------------------|
| Model | Acura TLX | |
| No. of Passengers: | | |
| Front | 2 | |
| Rear | 3 | |
| Total | 5 | |
| Weights: | | |
| Gross Vehicle Weight Rating | U.S.: 4,442 lbs (2,015 kg) | Canada: 2,055 kg |
| Gross Axle Weight Rating (Front) | U.S.: 2,370 lbs (1,075 kg) | Canada: 1,105 kg |
| Gross Axle Weight Rating (Rear) | U.S.: 2,094 lbs (950 kg) | Canada: 965 kg |
| Air Conditioning: | | |
| Refrigerant Type | HFC-134a (R-134a) | |
| Charge Quantity | 16.7 – 18.5 oz (475 – 525 g) | |
| Lubricant Type | ND-OIL 8 | |

Engine and Fuel

| | | |
|--------------------|---|------------------------------|
| Engine | | |
| Displacement | 144 cu-in (2,356 cm ³) | |
| Spark Plugs | NGK | DILKAR7H11GS DILKAR7G11GS |
| | DENSO | DXE22HQR-D11S |
| Fuel | | |
| Type | Unleaded premium gasoline, Pump octane number of 91 or higher | |
| Fuel Tank Capacity | 17.2 US gal (65 ℓ) | |

Tires

| | | |
|----------------------------|----------------------------------|-----------------|
| | Size | 225/55R17 97H |
| Regular | Pressure | 32 (220 [2.2]) |
| | psi (kPa [kgf/cm ²]) | |
| Compact Spare ¹ | Size | T135/80D17 103M |
| | Pressure | 60 (420 [4.2]) |
| Wheel Size | Regular | 17 x 7 1/2J |
| | Compact Spare ¹ | 17 x 4T |

*1: Vehicles with optional spare tire kit

Light Bulbs

| | |
|---|---------------------------------|
| Headlights (High/Low Beam) | LED |
| Front Side Marker/Parking Lights | LED |
| Front Turn Signal Lights | 24 W (PWY 24 W Amber/Silver) |
| Side Turn Signal Lights (on Door Mirrors) | LED |
| Brake/Taillights/Rear Side Marker Lights | LED |
| Brake/Taillights | LED |
| Back-Up Lights | 21 W |
| Rear Turn Signal Lights | 21 W |
| High-Mount Brake Light | LED |
| Rear License Plate Lights | LED |
| Interior Lights | |
| Front and Rear Map Lights | LED |
| Front and Rear Ambient Lights | LED |
| Vanity Mirror Lights | 1.4 W |
| Center Pocket Light | LED |
| Door Courtesy Lights | 3.4 W |
| Console Compartment Light | 1.4 W |
| Glove Box Light | 1.4 W |
| Door Inner Handle Lights | LED |
| Trunk Lights | 5 W |

Fluids

| | | |
|-------------|---------------------------------------|-------------------|
| Engine Oil | | |
| Recommended | Genuine Acura Motor Oil 0W-20 | |
| | API Premium-grade 0W-20 detergent oil | |
| Capacity | Change | 4.2 US qt (4.0 ℓ) |
| | Change including filter | 4.4 US qt (4.2 ℓ) |

| | | |
|----------------|--|--|
| Engine Coolant | | |
| Specified | Acura Long Life Antifreeze/Coolant Type2 | |
| Ratio | 50/50 with distilled water | |
| Capacity | 1.61 US gal (6.1 ℓ) | |
| | (change including the remaining 0.225 US gal (0.85 ℓ) in the reserve tank) | |

| | | |
|-------------|------------------------------------|--|
| Brake Fluid | | |
| Specified | Acura Heavy Duty Brake Fluid DOT 3 | |

| | | |
|--------------------------------|---|-------------------|
| Dual Clutch Transmission Fluid | | |
| Specified | Acura Automatic Transmission Fluid ATF TYPE 2.0 | |
| Capacity | Change | 3.3 US qt (3.1 ℓ) |

| | | |
|---------------|--|--|
| Washer Fluid | | |
| Tank Capacity | U.S.: 2.6 US qt (2.5 ℓ) Canada: 5.7 US qt (5.4 ℓ) | |

6-cylinder models

Vehicle

| | |
|----------------------------------|--|
| Model | Acura TLX |
| No. of Passengers: | |
| Front | 2 |
| Rear | 3 |
| Total | 5 |
| Weights: | |
| Gross Vehicle Weight Rating | U.S.: 4,586 lbs (2,080 kg) ^{*1} U.S.: 4,751 lbs (2,155 kg) ^{*2} Canada: 2,095 kg ^{*1} Canada: 2,170 kg ^{*2} |
| Gross Axle Weight Rating (Front) | U.S.: 2,535 lbs (1,150 kg) ^{*1} U.S.: 2,579 lbs (1,170 kg) ^{*2} Canada: 1,165 kg ^{*1} Canada: 1,180 kg ^{*2} |
| Gross Axle Weight Rating (Rear) | U.S.: 2,072 lbs (940 kg) ^{*1} U.S.: 2,194 lbs (995 kg) ^{*2} Canada: 945 kg ^{*1} Canada: 1,005 kg ^{*2} |
| Air Conditioning: | |
| Refrigerant Type | HFC-134a (R-134a) |
| Charge Quantity | 16.7 – 18.5 oz (475 – 525 g) |
| Lubricant Type | ND-OIL 8 |

*1: 2WD models
*2: AWD models

Fluids

| | | |
|-------------|--|-------------------|
| Recommended | Genuine Acura Motor Oil 0W-20 API Premium-grade 0W-20 detergent oil | |
| | Change | 4.2 US qt (4.0 ℓ) |
| Capacity | Change including filter | |
| | including filter | 4.5 US qt (4.3 ℓ) |

Engine Coolant

| | |
|-----------------|---|
| Specified Ratio | Acura Long Life Antifreeze/Coolant Type2 50/50 with distilled water |
| Capacity | 2.2 US gal (8.4 ℓ) (change including the remaining 0.19 US gal (0.72 ℓ) in the reserve tank) |

Brake Fluid

| | |
|-----------|------------------------------------|
| Specified | Acura Heavy Duty Brake Fluid DOT 3 |
|-----------|------------------------------------|

Automatic Transmission Fluid

| | |
|-----------|---|
| Specified | Acura Automatic Transmission Fluid ATF-TYPE 3.0 |
| Capacity | Change 3.5 US qt (3.3 ℓ) |

Washer Fluid

| | |
|---------------|--|
| Tank Capacity | U.S.: 2.6 US qt (2.5 ℓ) Canada: 5.7 US qt (5.4 ℓ) |
|---------------|--|

Rear Differential Fluid*

| | |
|-----------|----------------------------|
| Specified | Acura DPSF-II |
| Capacity | Change 1.97 US qt (1.86 ℓ) |

Transfer Assembly Fluid*

| | |
|-----------|--|
| Specified | Acura Hypoid Gear Oil HGO-1 Hypoid gear oil SAE 75W-85 or SAE 90 (API grade GL4 or GL5) |
| Capacity | Change 0.45 US qt (0.43 ℓ) |

*if equipped

Light Bulbs

| | |
|---|---------------------------------|
| Headlights (High/Low Beam) | LED |
| Fog Lights* | LED |
| Front Turn Signal Lights | 24 W (PWY 24 W Amber/Silver) |
| Front Side Marker/Parking Lights | LED |
| Side Turn Signal Lights (on Door Mirrors) | LED |
| Brake/Taillights/Rear Side Marker Lights | LED |
| Brake/Taillights | LED |
| Back-Up Lights | 21 W |
| Rear Turn Signal Lights | 21 W |
| High-Mount Brake Light | LED |
| Rear License Plate Lights | LED |
| Puddle Lights* | LED |
| Interior Lights | |
| Front and Rear Map Lights | LED |
| Front and Rear Ambient Lights | LED |
| Vanity Mirror Lights | 1.4 W |
| Center Pocket Light | LED |
| Door Courtesy Lights | 3.4 W |
| Console Compartment Light | 1.4 W |
| Glove Box Light | 1.4 W |
| Door Inner Handle Lights | LED |
| Trunk Lights | 5 W |

Engine and Fuel

| | | |
|--------------------|---|-------------|
| Engine | | |
| Displacement | 212 cu-in (3,471 cm ³) | |
| Spark Plugs | NGK | DILZKR7B11G |
| Fuel | | |
| Type | Unleaded premium gasoline, Pump octane number of 91 or higher | |
| Fuel Tank Capacity | 17.2 US gal (65 ℓ) | |

Tires

| | | |
|-----------------------------|---|-----------------|
| Regular | Size | 225/50R18 95H |
| | Pressure psi (kPa [kgf/cm ²]) | 32 (220 [2.2]) |
| Compact Spare ^{*1} | Size | T135/80D17 103M |
| | Pressure psi (kPa [kgf/cm ²]) | 60 (420 [4.2]) |
| Wheel Size | Regular | 18 x 7 1/2J |
| | Compact Spare ^{*1} | 17 x 4T |

*1: Vehicles with optional spare tire kit

CLIENT INFORMATION

Learn about information specific to you as an Acura client and how to get help.

Frequently Asked Questions/Troubleshooting

Below are some frequently asked questions and troubleshooting items that you may have about the vehicle.

Q: How do I set the vehicle clock?

A: For vehicles without navigation, see page 40. For vehicles with navigation, the time is automatically set using GPS signals.

Q: Why doesn't the vehicle start when I press the ENGINE START/STOP button?

A: The brake pedal must be pressed to start the engine.

Q: What is the AUTO setting on my headlight lever?

A: When in the AUTO position, the vehicle's exterior lights will automatically turn on or off depending on the ambient lighting.

Q: Why won't the driver's door unlock when I grab the door handle, even though the keyless access remote is within range?

A: If you pull the handle too quickly, the system may not have time to confirm the door is unlocked. Wait to hear a beep to confirm the door is unlocked. If you are wearing gloves, the system may be slow to respond.

Q: After my battery was disconnected or went dead, the audio system is asking for a code. Where do I find this?

A: In most cases, you do not need to enter a code. Turn on the vehicle and the audio system, and press and hold the power button until the system reactivates.

Q: Why can't I select an item using the interface dial?*

A: To prevent driver distraction, certain items are limited are inoperable while the vehicle is moving. Use voice commands or pull over to select the items.

Q: Where can I find the vehicle identification number (VIN)?

A: Check the label on the driver's doorjamb.

Q: Why can't I operate Pandora through the audio system?

A: Audio may be streaming through Bluetooth® Audio. Make sure Pandora mode is selected and the phone cable is properly connected to the USB adapter. Some phones may prompt you to "Allow" a connection.

*if equipped

Q: *Is my phone compatible with Bluetooth features?*

A: Visit www.acura.com/handsfreelink (U.S.) or www.handsfreelink.ca (Canada) to check phone compatibility for *Bluetooth*® Audio, *Bluetooth*® HandsFreeLink®, and SMS text messaging.

Q: *Every time I press the Talk button, the system gives me voice prompts. Can I turn these off?**

A: Press SETTINGS. Use the interface dial to select System Settings then Voice Prompt. Select Off.

**if equipped*

Contact Us

Acura dealer personnel are trained professionals. They should be able to answer all your questions. If you encounter a problem that your dealership does not solve to your satisfaction, please discuss it with the dealership's service manager or general manager. If you are dissatisfied with the decision made by the dealership's management, contact Acura Client Relations/Services.

U.S. Owners:

American Honda Motor Co., Inc.
Acura Client Relations
1919 Torrance Blvd.
Mail Stop 500-2N-7E
Torrance, CA 90501-2746
Tel: (800) 382-2238

In Puerto Rico and the U.S. Virgin Islands:

Bella International
P.O. Box 190816
San Juan, PR 00919-0816
Tel: (787) 620-7546

Canadian Owners:

Honda Canada, Inc.
Acura Client Services
180 Honda Blvd.
Markham, ON
L6C 0H9
Tel: (888) 922-8729
Fax: (877) 939-0909
E-Mail: acura_cr@ch.honda.com

When you call or write, please give us the following information:

- Vehicle Identification Number
- Date of purchase
- Odometer reading of your vehicle
- Your name, address, and telephone number
- A detailed description of the problem
- Name of the dealer who sold the vehicle to you

Acura Total Luxury Care Roadside Assistance

Your Acura TLC Roadside Assistance representative is here to help you 24 hours a day, 7 days a week by calling (800) 594-8500 (U.S.) or (800) 565-7587 (Canada). Under your 4-year/50,000-mile (80,000 km) warranty, the following benefits are available:

- Towing services — full cost of towing to the closest Acura dealer
- Roadside assistance — jump starting, fuel delivery, lockout, and flat tire
- Trip planning — detailed trip routing, emergency services, and more

Warranty Coverages

Below is a brief summary of the warranties covering your new vehicle.

New Vehicle Limited Warranty: Covers your new vehicle, except for the emissions control system and accessories, against defects in materials and workmanship.

Emissions Control Systems Defects Warranty and Emissions Performance Warranty: Covers your vehicle's emissions control systems. Time, mileage, and coverage are conditional.

Seat Belt Limited Warranty: Covers seat belts that fail to function properly.

Rust Perforation Limited Warranty: Covers all exterior body panels that rust through from the inside.

Accessory Limited Warranty: Covers Acura accessories.

Replacement Parts Limited Warranty: Covers all Acura replacement parts against defects in materials and workmanship.

Replacement Battery Limited Warranty: Provides prorated coverage for a replacement battery purchased from an Acura dealer.

Replacement Muffler Lifetime Limited Warranty: Covers a replacement muffler for the duration of the ownership.

Restrictions and exclusions apply to all these warranties. See the Owner Information CD or visit owners.acura.com (U.S.) or www.myacura.ca (Canada) for complete descriptions of each warranty, including time, mileage, and other conditional limitations.

Your vehicle's original tires are covered by their manufacturer. Tire warranty information can be found on the Owner Information CD or owners.acura.com (U.S.) or www.myacura.ca (Canada).

VOICE COMMAND INDEX

Learn about all available voice commands to help you operate the vehicle. Press the Talk button each time you want to say a command.

To view a list of available commands in the vehicle, press INFO and use the interface dial to select Voice Info. Select a category to hear the commands read aloud.

■ General Commands

The system accepts these commands on any screen.

- Display voice portal
- Voice help
- Display map
- Display menu
- Display settings
- Display destination
- Display information
- Display audio
- Display phone
- Back
- Cancel
- Messages
- What is today's date?
- What time is it?
- Go home

■ Navigation Commands

The system accepts these commands on the map/guidance screen.

Map Display Commands

- Display current location
- Display north up/heading up/3D map
- Display zoom in/zoom out
- Display/Hide (specify icon type):
 - ATM
 - gas station
 - restaurant
 - post office
 - grocery store
 - lodging (hotel, motel)
 - parking garage
 - parking lot
 - school
 - hospital
 - freeway exit information
 - traffic
 - traffic speeds
 - traffic icons
 - traffic incidents

Route Commands

The system accepts these commands when a route is set.

- How long to the destination?
- How far to the destination?
- Display destination map
- Display entire route
- Cancel route
- Repeat guidance
- Go home

■ Navigation Commands (continued)

Find Place Commands

Find nearest (specify place):

- Fuel and auto
- Acura dealer
- Gas station
- Auto parts & electronics
- Auto repair & maintenance
- Car wash & detailing
- Motorcycle dealers
- Other car dealers
- Roadside assistance
- ATM and bank
- ATM
- Bank
- Check cashing
- Currency exchange
- Community
- Business
- City hall
- Civic center
- Convention center
- Court house
- Higher education
- Library
- Post office
- School
- Emergency room
- Hospital
- Police station
- Veterinarian
- Lodging
- Bed & breakfast
- Hotel
- Resort
- Recreation
- Amusement park
- Golf course
- Historical monument
- Marina
- Movie theater
- Museum
- Park
- Performing arts
- Sports complex
- Tourist attraction
- Restaurant
- American restaurant
- Californian restaurant
- Chinese restaurant
- Coffee shop
- Continental restaurant
- Fast food
- French restaurant
- German restaurant
- Greek restaurant
- Indian restaurant
- Italian restaurant
- Japanese restaurant
- Korean restaurant
- Mexican restaurant
- Pizza
- Seafood restaurant
- Thai restaurant
- Vegetarian restaurant
- Vietnamese restaurant
- Other restaurant
- Shopping
- Shopping area
- Accessory store
- Book store
- Clothing store
- Grocery store
- Home improvement store
- Mall
- Office supply store
- Pharmacy
- Pet food store
- Sewing store
- Shoe store
- Sporting goods store
- Toy store
- Travel center
- Airport
- Automobile club

Find nearest (specify place):

- | | |
|-----------------------|---------------------|
| Bus station | Rest area |
| Camping | Ski area |
| Commuter rail station | Tourist information |
| Ferry terminal | Train station |
| Named place | Travel agency |
| Park & ride | Truck stop |
| Parking garage | |
| Parking lot | |
| Rental car agency | |

■ Climate Control Commands

The system accepts these commands on most screens.

- | | |
|---|---|
| <ul style="list-style-type: none"> • Climate control automatic* • Climate control off* • Air conditioner on* • Air conditioner off* • Climate control defrost on* • Climate control defrost off* • Rear defrost on* • Rear defrost off* • Climate control fresh air • Climate control recirculate • Climate control vent • Climate control bi-level • Climate control floor • Climate control floor and defrost • Climate control mode automatic • Fan speed up • Fan speed down • Fan speed # (#: 1 to 7) • Fan automatic • Temperature # (#: 57 to 87°F, 15 to 29°C) degrees • Driver temperature # degrees (#: 57 to 87°F, 15 to 29°C) • Passenger temperature # degrees (#: 57 to 87°F, 15 to 29°C) • Temperature up • Temperature down • Driver temperature up • Driver temperature down • Passenger temperature up | <ul style="list-style-type: none"> • Passenger temperature down • Temperature max heat • Temperature max cool • Driver temperature max heat • Driver temperature max cool • Passenger temperature max heat • Passenger temperature max cool • Climate control sync on* • Climate control sync off* • Driver heated seat off • Passenger heated seat off • Driver heated seat high • Driver heated seat medium • Driver heated seat low • Passenger heated seat high • Passenger heated seat medium • Passenger heated seat low • Driver ventilated seat automatic** • Driver ventilated seat high** • Driver ventilated seat low** • Driver ventilated seat off** • Passenger ventilated seat automatic** • Passenger ventilated seat high** • Passenger ventilated seat low** • Passenger ventilated seat off** |
|---|---|

* These commands toggle the function on and off, so the command may not match your intended action.

**if equipped

■ Audio Commands

The system accepts these commands on most screens. Audio volume levels cannot be controlled using voice commands.

FM/AM Radio Commands

- | | |
|--|---|
| <ul style="list-style-type: none"> • Audio on* • Audio off* • Radio on* • Radio off* • Radio select FM • Radio select AM • Radio tune to # FM (#: frequency, e.g., 95.5) • Radio tune to # AM (#: frequency, e.g., 1020) | <ul style="list-style-type: none"> • Radio seek up • Radio seek down • Radio next station • Radio preset # (#: 1 to 12) • Radio FM preset # (#: 1 to 12) • Radio AM preset # (#: 1 to 6) • Radio scan* |
|--|---|

SiriusXM® Radio Commands

- | | |
|---|---|
| <ul style="list-style-type: none"> • Radio select XM • XM channel # (#: 0 to 255) • XM channel up • XM channel down • XM category up | <ul style="list-style-type: none"> • XM category down • XM preset # (#: 1 to 12) • XM scan* • XM category mode • XM channel mode |
|---|---|

Disc Commands

- | | |
|--|---|
| <ul style="list-style-type: none"> • Disc play • Disc play track # (#: 1 to 30) • Disc skip forward • Disc skip back • Disc track random* • Disc track repeat* • Disc track scan* • Disc folder up | <ul style="list-style-type: none"> • Disc folder down • Disc folder random* • Disc folder repeat* • Disc folder scan* • Disc normal play |
|--|---|

Hard Disc Drive (HDD) Commands

- | | |
|---|---|
| <ul style="list-style-type: none"> • Hard disc drive play • Hard disc drive play track # (#: 1-30) • Hard disc drive skip forward • Hard disc drive skip back • Hard disc drive album up* • Hard disc drive album down* • Hard disc drive track up • Hard disc drive track down • Hard disc drive playlist up* | <ul style="list-style-type: none"> • Hard disc drive playlist down* • Hard disc drive track repeat* • Hard disc drive track scan* • Hard disc drive track random* • Hard disc drive normal play • What/Who am I listening to? • Who is this? • What's playing? • Who's playing? • What album is this? |
|---|---|

* These commands toggle the function on and off, so the command may not match your intended action.

USB Commands

- USB play
- USB play track # (#: 1 to 30)
- USB skip forward
- USB skip back
- USB track random*
- USB track repeat*
- USB track scan*
- USB folder up
- USB folder down
- USB folder random*
- USB folder repeat*
- USB folder scan*
- USB normal play

iPod® Commands

- iPod play
- iPod play track # (#: 1-30)
- iPod skip forward
- iPod skip back
- iPod track shuffle*
- iPod album shuffle*
- iPod track repeat*
- iPod normal play
- What/Who am I listening to?
- Who is this?
- What's playing?
- Who's playing?
- What album is this?

Pandora® Commands

- Pandora play
- Pandora skip forward
- Pandora station up
- Pandora station down
- Pandora pause
- Pandora resume
- Pandora thumbs up
- Pandora thumbs down

Aha Radio™ Commands

- Aha radio play
- Aha radio skip forward
- Aha radio skip back
- Aha radio station up
- Aha radio station down
- Aha radio pause
- Aha radio resume
- Aha radio like
- Aha radio dislike

Bluetooth® Audio Commands

Commands may not work on some phones or devices.

- *Bluetooth* audio play
- *Bluetooth* audio skip forward
- *Bluetooth* audio skip back
- *Bluetooth* audio pause
- *Bluetooth* audio resume
- *Bluetooth* audio group up
- *Bluetooth* audio group down
- *Bluetooth* audio track random
- *Bluetooth* audio track repeat

AUX Commands

- Auxiliary play

Song By Voice™ Commands

Available for tracks stored on the HDD or iPod®.

- Music search
- What/Who am I listening to?
- Who is this?
- What's playing?
- Who's playing?
- What album is this?

■ Phone Commands

The system accepts these commands on the Voice Portal screen.

- Dial by number
- Dial by voice tag
- Dial (number)
- Dial (contact name)

■ On-screen Commands

The system accepts these commands on any screen where applicable. All available on-screen voice commands are highlighted in yellow when you press the Talk button.

- Next (or Down)
- Previous (or Up)
- OK
- Delete

■ Info Commands

The system accepts these commands on the Info screen.

- AcuraLink messages
- Trip computer
- Traffic information
- Display clock/wallpaper

* These commands toggle the function on and off, so the command may not match your intended action.

INDEX

ABS (Anti-lock Brake System) indicator.....23
 ACC indicator23, 25
 AcuraLink®62
 ASSIST button63
 Emergency Assistance.....63
 LINK button64
 Messages62
 Operator Assistance.....64
 Security Features64
 Subscription Features.....63
 AcuraLink featuring Aha™54
 AcuraLink Real-Time Traffic71
 Adaptive Cruise Control (ACC) with Low Speed Follow (LSF)86
 Advanced Airbags8
 Aha Radio™54
 Aha Radio™ Commands138
 Airbags8
 About Your Airbags.....10
 Advanced Airbags.....8
 Airbag Care.....13
 Airbag System Components.....12
 Airbag System Indicators10
 Driver's Knee Airbag.....8
 Front Airbags (SRS).....8
 Passenger Airbag Off indicator.....11
 Side Airbags9
 Side Curtain Airbags.....9
 SRS indicator10
 Anti-Lock Brake System (ABS)23, 81
 ASSIST button63
 Audio Commands137
 Audio Operation44
 Aha Radio™54
 Auxiliary Input Jack.....44
 Bluetooth® Audio.....51
 Compact Disc (CD).....49
 FM/AM Radio.....47
 Hard Disc Drive (HDD) Audio.....52
 iPod®50
 On-Demand Multi-Use Display (ODMD).....46
 Pandora®53
 SiriusXM® Radio.....48
 Sound45
 Steering Wheel Controls45
 USB Adapter Cable44
 USB Flash Drive50
 Automatic Brake Hold25, 82
 Automatic Dimming Rearview Mirror.....39
 Automatic Rain-Sensing Wipers33
 Auto Idle Stop83
 Auto idle stop indicator.....24, 25

Auto Park Mode79
 AUX Commands.....139
 Auxiliary Input Jack.....44
 Battery119
 Blind Spot Information (BSI) System...23, 93
 Bluetooth® Audio51
 Bluetooth® Audio Commands.....138
 Bluetooth® HandsFreeLink®.....55
 Call History60
 Dialing a Number.....58
 Displays and Controls55
 E-Mail.....61
 Making a Call58
 On-Demand Multi-Use Display (ODMD).....56
 Pairing a Phone.....57
 Phonebook.....59
 SMS Text Messaging.....61
 Speed Dial.....59, 60
 Voice Command Tips.....56
 Brake Assist System.....81
 Brake Hold25, 82
 Brake system indicator22, 23
 Braking81
 Brightness Control.....32
 BSI indicator23, 25
 Call History60
 Carbon Monoxide Gas4
 Car Wash Mode80
 Change a Setting.....40
 Changing a Flat Tire.....105
 Changing Fuses110
 Charging system indicator22
 Childproof Door Locks.....29
 Child Safety14
 Childproof Door Locks.....29
 Protecting Child Passengers14
 Protecting Infants.....15
 Protecting Larger Children19
 Protecting Smaller Children.....16
 Child Seat16
 Adding Security with a Tether19
 Installing a Child Seat18
 LATCH-Compatible Child Seat.....17
 Selecting a Child Seat16
 Client Information.....131
 Climate Control Commands.....136
 Climate Control System42
 Clock40
 CMBS indicator23, 25
 Collision Mitigation Braking System™ (CMBS™).....91
 Compact Disc (CD)49
 Compact Disc (CD) Commands137

Condition Indicators.....24
 Contact Us132
 Cross Traffic Monitor.....96
 Cruise Control25, 85
 Customized Features.....40
 Dashboard and Ceiling Controls2
 Detour71
 Dialing a Number.....58
 Door Mirrors39
 Doors28
 Childproof Door Locks29
 Front Door Inner Handle29
 Lock Tab29
 Master Door Lock Switch.....29
 DOT Tire Quality Grading125
 Driver's Knee Airbag8
 Driving72
 Driving Position Memory System37
 ECON mode indicator25
 Electric Parking Brake.....23, 24, 81
 Electric Power Steering (EPS) indicator.....23
 Electronic Gear Selector79
 Electronic Stability Control (ESC) System...84
 E-Mail61
 Emergency Assistance.....63
 Emergency Engine Stop.....102
 Emergency Towing.....102
 Engine and Fuel129, 130
 Engine Coolant118
 Engine Oil116
 Engine Oil Life.....117
 Engine Start/Stop Button.....76
 EPS indicator23
 Exterior Lights25, 32
 Fastening a Seat Belt.....7
 FCW indicator.....23, 25
 Find Nearest Place.....69
 Find Place Commands.....135
 Flat Tire105
 Floor Mats37
 Fluids129, 130
 FM/AM Radio.....47
 FM/AM Radio Commands137
 Fog lights indicator.....25
 Foot Brake81
 Forward Collision Warning (FCW) with Pedestrian Detection.....23, 88
 Frequently Asked Questions131
 Front Airbags (SRS).....8
 Front Door Inner Handle29
 Front Seats35
 Fuel Information97
 Fuse Locations.....108
 Changing Fuses110
 Driver's Side Interior Fuse Boxes.....109

Engine Compartment Fuse Boxes.....108
 Garage Opener.....41
 Gear Selector.....79
 Hard Disc Drive (HDD) Audio.....52
 Hard Disc Drive (HDD) Commands.....137
 Headlight Washers34
 Headlight-Wiper Integration.....33
 Head Restraints.....36
 Heated Steering Wheel38
 Heated Windshield Button34
 High beams indicator.....25
 Home Address68
 HomeLink®41
 Hood114
 IDS button.....84
 Immobilizer indicator.....24
 Info Commands.....139
 Installing a Child Seat18
 Instrument Panel22
 Condition Indicators.....24
 Malfunction Indicators22
 On/Off Indicators.....25
 Integrated Dynamics System (IDS).....84
 Interface Dial Feedback67
 Interior Lights32
 Intermittent Wipers33
 iPod®50
 iPod® Commands138
 Jump Starting99
 Keyless Access System.....23, 28
 Lane Departure Warning (LDW)23, 89
 Lane Keeping Assist System (LKAS).....90
 Lap/Shoulder Seat Belts.....5
 LATCH-Compatible Child Seat.....17
 LDW indicator23
 Light Bulbs.....129, 130
 Lights25, 32
 Brightness Control.....32
 Exterior Lights32
 Interior Lights32
 LINK button64
 LKAS indicator23, 25
 Locking the Doors.....28
 Lock Tab29
 Low fuel indicator24
 Low oil pressure indicator22
 Low Speed Follow (LSF).....86
 Low tire pressure indicator.....24
 Maintenance.....111
 Opening the Hood.....115
 Safety Precautions.....111
 Service Codes.....112
 Under the Hood.....114
 Maintenance Minder™112
 Making a Call58

TABLE OF CONTENTS
 VISUAL INDEX
 SAFETY INFORMATION
 INSTRUMENT PANEL
 VEHICLE CONTROLS
 AUDIO AND CONNECTIVITY
 BLUETOOTH® HANDSFREELINK®
 ACURALINK®

NAVIGATION
 DRIVING
 HANDLING THE UNEXPECTED
 MAINTENANCE
 SPECIFICATIONS
 CLIENT INFORMATION
 VOICE COMMAND INDEX
 INDEX

Malfunction indicator lamp22

Malfunction Indicators22

Map Display Commands 134

Map Legend..... 66, 70

Master Door Lock Switch29

Maximum Load Limit73

Mirrors 39

Moonroof31

Multi-Information Display26

Multi-View Rear Camera95

Navigation65

 AcuraLink Real-Time Traffic™ 71

 Detour71

 Display and Controls 66

 Entering a Destination 68

 Find Nearest Place69

 Home Address 68

 Interface Dial Feedback67

 Map Legend..... 66, 70

 Place Category 69

 Routing70

 Steering Wheel Controls65

 Street Address 68

 System Guidance Volume67

 Traffic71

 Voice Command Tips.....65

 Voice Prompt.....67

Navigation Commands..... 134

Neutral (Car Wash Mode)80

On-Demand Multi-Use Display (ODMD) ...46

One-Touch Turn Signal 33

On/Off Indicators.....25

Opening the Hood115

Opening the Trunk28

Operator Assistance 64

Overheating101

Pairing a Phone.....57

Pandora®53

Pandora® Commands 138

Parking Brake81

Parking Sensor System..... 94

Passenger Airbag Off Indicator11

Phone57

Phonebook59

Phone Commands139

Place Category 69

Power Door Mirrors.....39

Power Mode76

Power Moonroof31

Power Windows 30

Precision All-Wheel Steer™ (P-AWS®).....22

Protecting Child Passengers14

Protecting Infants15

Protecting Larger Children19

Protecting Smaller Children16

Radio47

Rain-Sensing Wipers 33

RDM indicator23

Readiness Codes.....128

Rear Camera95

Rearview Mirror39

Refueling97

Remote Battery Strength98

Remote Engine Start75

Remote Transmitter27

Reporting Safety Defects21

Reserve Tank118

Reverse Tilt Door Mirrors 39

Road Departure Mitigation (RDM) System...23, 92

Roadside Assistance133

Route Commands 134

Routing70

Safety Information3

 Carbon Monoxide Gas4

 Child Safety.....14

 Important Safety Information.....3

 Important Safety Precautions3

 Reporting Safety Defects21

 Safety Label Locations20

 Safety Messages.....3

Seat Belts5

 Adjusting the Shoulder Anchor7

 Fastening a Seat Belt7

 Lap/Shoulder Seat Belts5

 Seat Belt Inspection6

 Seat belt reminder indicator24

Seat Heaters43

Seat Ventilation43

Seats35

Sequential Mode.....80

Sequential Shift Mode78

Service Codes112

Settings40

Setting the Clock40

SH-AWD indicator.....24

Shifting77

 Electronic Gear Selector79

 Sequential Mode.....80

 Sequential Shift Mode78

 Shift Lever77

 Shift Lever Does Not Move.....98

Shoulder Anchor7

Side Airbags9

Side Curtain Airbags.....9

SiriusXM® Radio48

SiriusXM® Radio Commands137

SMS Text Messaging.....61

Song By Voice™ Commands.....139

Sound45

Specifications129

Speed Dial59, 60

SPORT mode indicator25

Supplemental Restraint System indicator ...10, 23

START/STOP button76

Steering Wheel38

Steering Wheel and Nearby Controls 1

Steering Wheel Controls 45, 55, 65

Street Address 68

Super Handling-All Wheel Drive (AWD) ... 94

System Guidance Volume67

System message indicator24

Text Messaging.....61

Tire Chains123

Tire Information121

 Inflation Guidelines 121

 Inspection Guidelines121

 Tire and Loading Information Label122

 Tire and Wheel Replacement.....122

 Tire Grading125

 Tire Labeling.....124

 Tire Identification Number (TIN).....124

 Tire Service Life123

 Tire Terminology124

 Wear Indicators121

 Winter Tires.....123

Tire Pressure Monitoring System (TPMS)..... 23, 103, 127

Tire Repair Kit 104

Tires129, 130

TPMS indicator23

Traffic71

Troubleshooting131

Trunk28

Trunk Release Button.....30

Turn-by-turn directions70

Turn Signal33

Turn signal indicator25

Under the Hood114

Unlocking the Doors28

USB Adapter Cable44

USB Commands138

USB Flash Drive.....50

Vehicle Controls.....27

Vehicle Stability Assist (VSA®).....23, 84

Visual Index1

Voice Command Index..... 134

Voice Command Tips.....56, 65

Voice Prompt67

VSA indicator.....23

VSA off indicator.....25

Warranty Coverages133

Wear Indicators121

Windows30

Window Washer Fluid119

Winter Tires.....123

Wipers33

Wiper Blades.....102

XM® Radio48

XM® Radio Commands.....137

TABLE OF CONTENTS
VISUAL INDEX
SAFETY INFORMATION
INSTRUMENT PANEL
VEHICLE CONTROLS
AUDIO AND CONNECTIVITY
BLUETOOTH® HANDSFREELINK®
ACURALINK®

NAVIGATION
DRIVING
HANDLING THE UNEXPECTED
MAINTENANCE
SPECIFICATIONS
CLIENT INFORMATION
VOICE COMMAND INDEX
INDEX