

## Adding Engine Oil, Changing the Oil and Filter

---

Honda Motor Oil is the preferred 5W-20 lubricant for your vehicle. It is highly recommended that you use Honda Motor Oil in your vehicle for optimum engine protection. Make sure the API Certification Seal says "For Gasoline Engines."

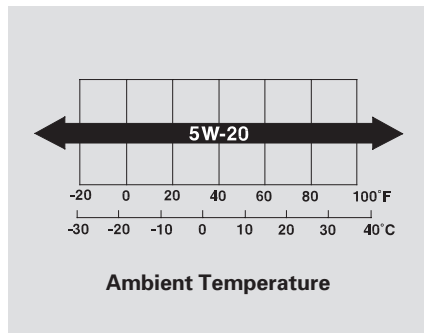

The oil viscosity or weight is provided on the container's label. 5W-20 oil is formulated for year-round protection of your vehicle to improve cold weather starting and fuel economy.

### Synthetic Oil

You may use a synthetic motor oil if it meets the same requirements given for a conventional motor oil: it displays the API Certification Seal, and it is the proper weight. You must follow the oil and filter change intervals given on the maintenance schedule.

### Engine Oil Additives

Your vehicle does not require any oil additives. Additives may adversely affect your engine's or transmission's performance and durability.

### Changing the Oil and Filter

Always change the oil and filter according to the recommendations in the maintenance schedule. The oil and filter collect contaminants that can damage your engine if they are not removed regularly.

Changing the oil and filter requires special tools and access from underneath the vehicle. The vehicle should be raised on a service station-type hydraulic lift for this service. Unless you have the knowledge and proper equipment, you should have this maintenance done by a skilled mechanic.

1. Run the engine until it reaches normal operating temperature, then shut it off.

## Changing the Oil and Filter

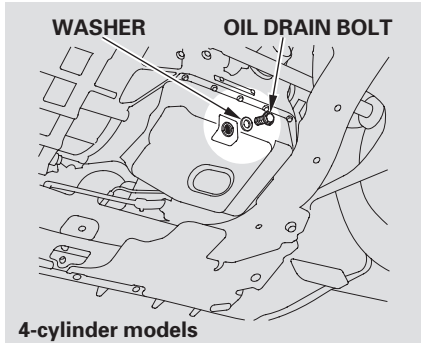

2. Open the hood, and remove the engine oil fill cap. Remove the oil drain bolt and washer from the bottom of the engine. Drain the oil into an appropriate container.

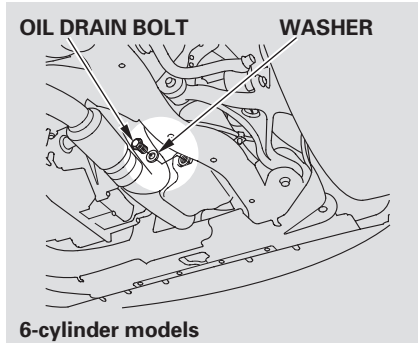

3. Remove the oil filter, and let the remaining oil drain. A special wrench (available from your dealer) is required.

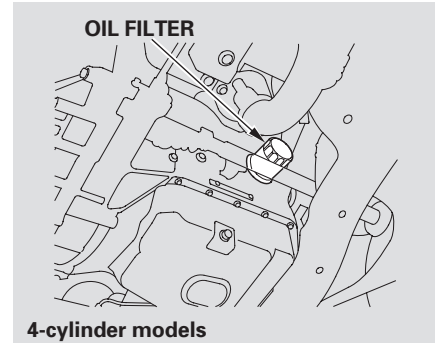

4. Install a new oil filter according to the instructions that come with it.

Make sure to clean off any dirt and dust on the connecting surface of a new oil filter.

CONTINUED

## Changing the Oil and Filter

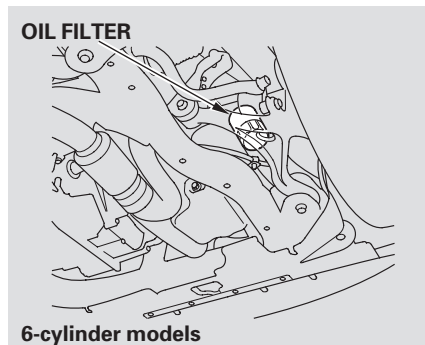

5. Put a new washer on the drain bolt, then reinstall the drain bolt. Tighten the drain bolt to :

(4-cylinder models)  
33 lbf-ft (44 N·m , 4.5 kgf-m)

(6-cylinder models)  
29 lbf-ft (39 N·m , 4.0 kgf-m)

6. Refill the engine with the recommended oil.

Engine oil change capacity  
(including filter):

(4-cylinder models)  
4.4 US qt (4.2 l)

(6-cylinder models)  
4.5 US qt (4.3 l)

7. Replace the engine oil fill cap. Start the engine. The oil pressure indicator should go out within 5 seconds. If it does not, turn off the engine, and check your work.
8. Let the engine run for several minutes, then check the drain bolt and oil filter for leaks.

9. Turn off the engine and let it sit for several minutes, then check the oil level on the dipstick. If necessary, add more oil.

### NOTICE

*Improper disposal of engine oil can be harmful to the environment. If you change your own oil, please dispose of the used oil properly. Put it in a sealed container and take it to a recycling center. Do not discard it in a trash bin or dump it on the ground.*