

2005 Insight Online Reference Owner's Manual

Use these links (and links throughout this manual) to navigate through this reference.
For a printed owner's manual, click on authorized manuals or go to www.helminc.com.

Contents

Owner's Identification Form

Introduction	i
A Few Words About Safety	ii
Your Vehicle at a Glance	4
Driver and Passenger Safety	7
Seat belts, SRS, and child protection	
Instruments and Controls	41
Indicators, gauges, dashboard, and steering column	
Comfort and Convenience Features	73
Climate, audio, steering wheel, security, cruise control, and HomeLink	
Before Driving	93
Fuel, vehicle break-in, and cargo loading	
Driving	107
Engine and transmission operation	
Maintenance	125
Schedules, fluid checking, minor services, and vehicle storage	
Taking Care of the Unexpected	165
Flat tire, dead battery, overheating, fuses	
Technical Information	191
Vehicle specifications, tires, fuels, and emissions controls	
Warranty and Customer Relations (U.S. and Canada Only)	203
Warranty and contact information	
Authorized Manuals (U.S. only)	207
How to order	
Index	I
Service Information Summary	
Fluid capacities and tire pressures	

Owner's Identification

OWNER _____

ADDRESS _____

STREET

_____ CITY

STATE/PROVINCE

ZIP CODE/
POSTAL CODE

V. I. N. _____

DELIVERY DATE _____

(Date sold to original retail purchaser)

DEALER NAME _____ DEALER NO. _____

ADDRESS _____

STREET

_____ CITY

STATE/PROVINCE

ZIP CODE/
POSTAL CODE

OWNER'S SIGNATURE _____

DEALER'S SIGNATURE _____

This Owner's Manual should be considered a permanent part of the vehicle and should remain with the vehicle when it is sold.

This Owner's Manual covers all models of the Insight. You may find descriptions of equipment and features that are not on your particular model.

The information and specifications included in this publication were in effect at the time of approval for printing. Honda Motor Co., Ltd. reserves the right, however, to discontinue or change specifications or design at any time without notice and without incurring any obligation whatsoever.

Congratulations! Your selection of a 2005 Honda Insight was a wise investment. It will give you years of driving pleasure.

One of the best ways to enhance the enjoyment of your new Honda is to read this manual. In it, you will learn how to operate its driving controls and convenience items. Afterwards, keep this owner's manual in your vehicle so you can refer to it at any time.

Several warranties protect your new Honda. Read the warranty booklet thoroughly so you understand the coverages and are aware of your rights and responsibilities.

Maintaining your vehicle according to the schedules given in this manual helps to keep your driving trouble-free while it preserves your investment. When your vehicle needs maintenance, keep in mind that your Honda dealer's staff is specially trained in servicing the many systems unique to your Honda. Your Honda dealer is dedicated to your satisfaction and will be pleased to answer any questions and concerns.

As you read this manual, you will find information that is preceded by a **NOTICE** symbol. This information is intended to help you avoid damage to your vehicle, other property, or the environment.

California Proposition 65 Warning

WARNING: This product contains or emits chemicals known to the State of California to cause cancer and birth defects or other reproductive harm.

Event Data Recorders

This vehicle is equipped with one or more recording devices commonly referred to as event data recorders or sensing and diagnostic modules.

A Few Words About Safety

Your safety, and the safety of others, is very important. And operating this vehicle safely is an important responsibility.

To help you make informed decisions about safety, we have provided operating procedures and other information on labels and in this manual. This information alerts you to potential hazards that could hurt you or others.

Of course, it is not practical or possible to warn you about all the hazards associated with operating or maintaining your vehicle. You must use your own good judgement.

You will find this important safety information in a variety of forms, including:

- **Safety Labels** — on the vehicle.
- **Safety Messages** — preceded by a safety alert symbol  and one of three signal words: **DANGER**, **WARNING**, or **CAUTION**. These signal words mean:

 **DANGER**

You **WILL** be **KILLED** or **SERIOUSLY HURT** if you don't follow instructions.

 **WARNING**

You **CAN** be **KILLED** or **SERIOUSLY HURT** if you don't follow instructions.

 **CAUTION**

You **CAN** be **HURT** if you don't follow instructions.

- **Safety Headings** — such as Important Safety Reminders or Important Safety Precautions.
- **Safety Section** — such as Driver and Passenger Safety.
- **Instructions** — how to use this vehicle correctly and safely.

This entire book is filled with important safety information — please read it carefully.

Your Vehicle at a Glance

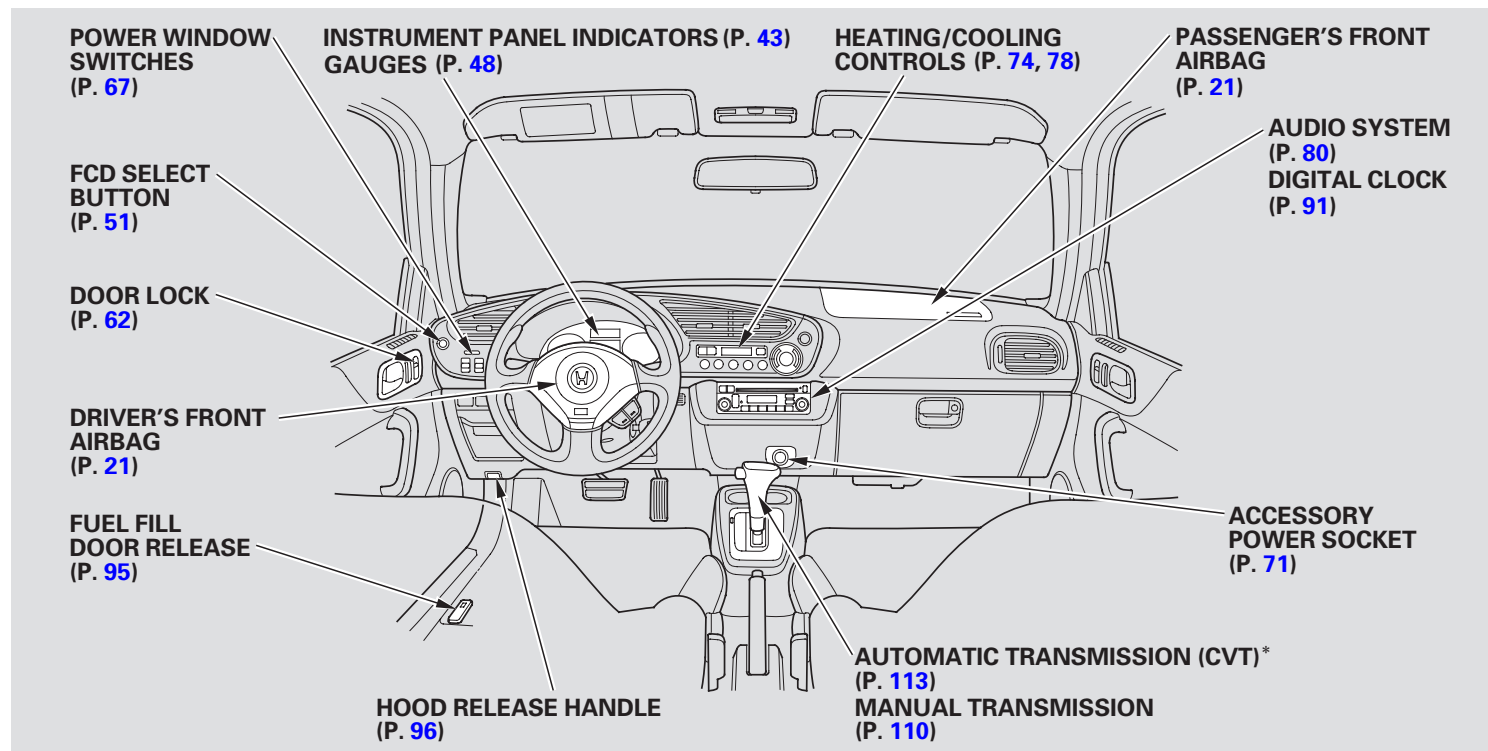

* U.S. model

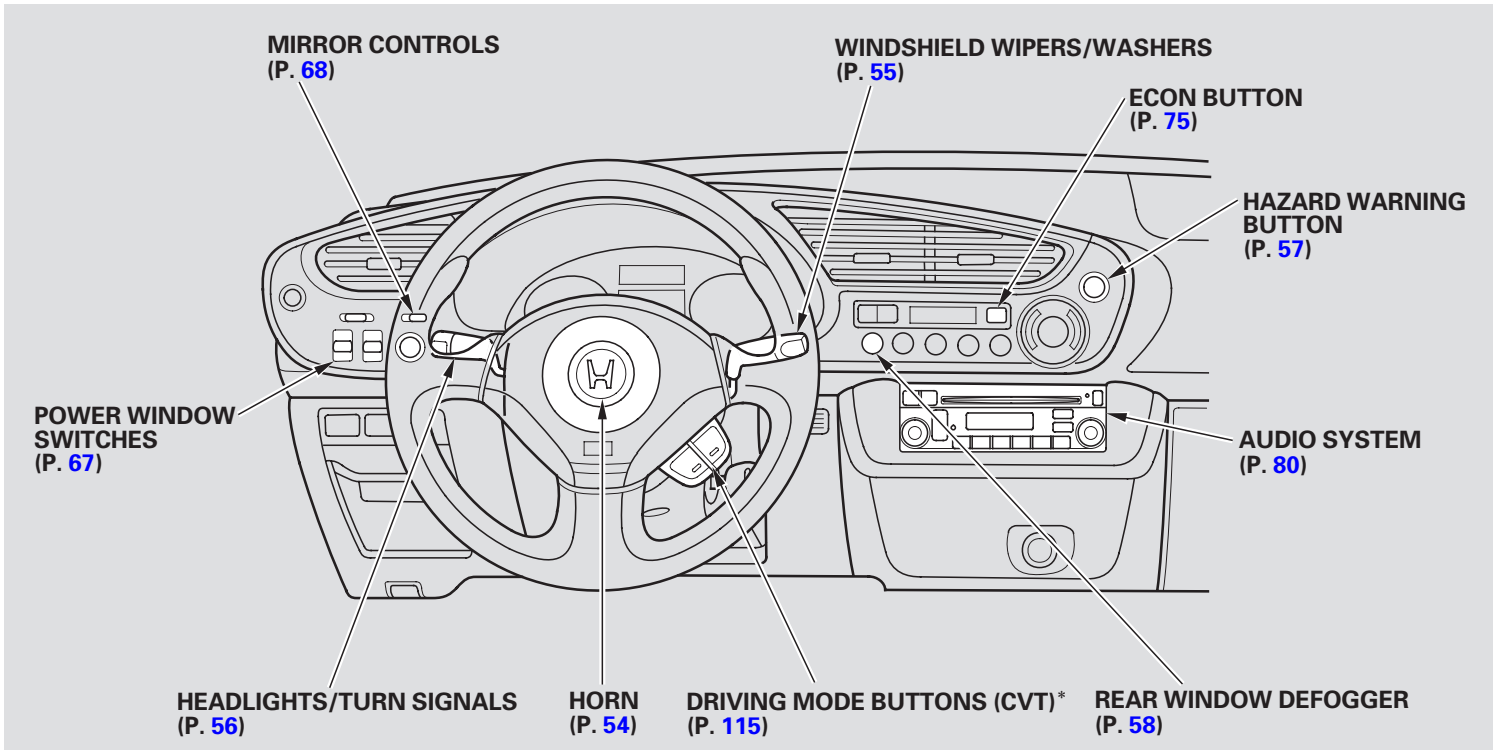

* U.S. model

This section gives you important information about how to protect yourself and your passenger. It shows you how to use seat belts. It explains how your airbags work. And it tells you how to properly restrain children in your vehicle.

Important Safety Precautions	8	How the SRS Indicator Works...	23
Your Vehicle's Safety Features.....	9	Airbag Service	23
Seat Belts	10	Additional Safety Precautions....	24
Airbags.....	11	Protecting Children –	
Protecting Adults and Teens.....	12	General Guidelines.....	25
1. Close and Lock the Doors	12	All Children Must Be	
2. Adjust the Seats	12	Restrained	25
3. Adjust the Seat-Backs	13	Your Vehicle is Not	
4. Fasten and Position the		Recommended for Child	
Seat Belts.....	14	Passengers	26
5. Maintain a Proper Sitting		The Passenger's Front Airbag	
Position	15	Poses Serious Risks.....	26
Advice for Pregnant Women.....	16	Additional Safety Precautions....	28
Additional Safety Precautions....	17	Protecting Small Children	29
Additional Information About Your		Selecting a Child Seat.....	30
Seat Belts.....	18	Installing a Child Seat	30
Seat Belt System Components...	18	Protecting Larger Children	34
Lap/Shoulder Belt	18	Checking Seat Belt Fit	34
Automatic Seat Belt		Using a Booster Seat.....	35
Tensioners.....	19	When Can a Larger Child	
Seat Belt Maintenance	19	Ride in This Vehicle	36
Additional Information About		Additional Safety Precautions....	37
Your Airbags.....	21	Carbon Monoxide Hazard	38
Airbag System Components.....	21	Safety Labels	39
How Your Front Airbags			
Work.....	21		

Important Safety Precautions

You'll find many safety recommendations throughout this section, and throughout this manual. The recommendations on this page are the ones we consider to be the most important.

Always Wear Your Seat Belt

A seat belt is your best protection in all types of collisions. Airbags are designed to supplement seat belts, not replace them. So even though your vehicle is equipped with airbags, make sure you and your passenger always wear your seat belts, and wear them properly (see page [14](#)).

Your Vehicle is Not Recommended for Child Passengers

Since all children are safest in the back seat of a vehicle, and your vehicle does not have a back seat, we recommend that you do not carry a child passenger.

Due to the passenger's airbag hazard, you should never carry an infant in a rear-facing child seat in this vehicle.

If an older child must ride in this vehicle, follow all child safety instructions and warnings in this manual (see pages [25](#) – [37](#)).

Be Aware of Airbag Hazards

While airbags can save lives, they can cause serious or fatal injuries to occupants who sit too close to them, or are not properly restrained. Infants, young children, and short adults are at the greatest risk. Be sure to follow all instructions and warnings in this manual.

Don't Drink and Drive

Alcohol and driving don't mix. Even one drink can reduce your ability to respond to changing conditions, and your reaction time gets worse with every additional drink. So don't drink and drive, and don't let your friends drink and drive, either.

Control Your Speed

Excessive speed is a major factor in crash injuries and deaths. Generally, the higher the speed, the greater the risk, but serious injuries can also occur at lower speeds. Never drive faster than is safe for current conditions, regardless of the maximum speed posted.

Keep Your Vehicle in Safe Condition

Having a tire blowout or a mechanical failure can be extremely hazardous. To reduce the possibility of such problems, check your tire pressures and condition frequently, and perform all regularly scheduled maintenance (see page [127](#)).

Your Vehicle's Safety Features

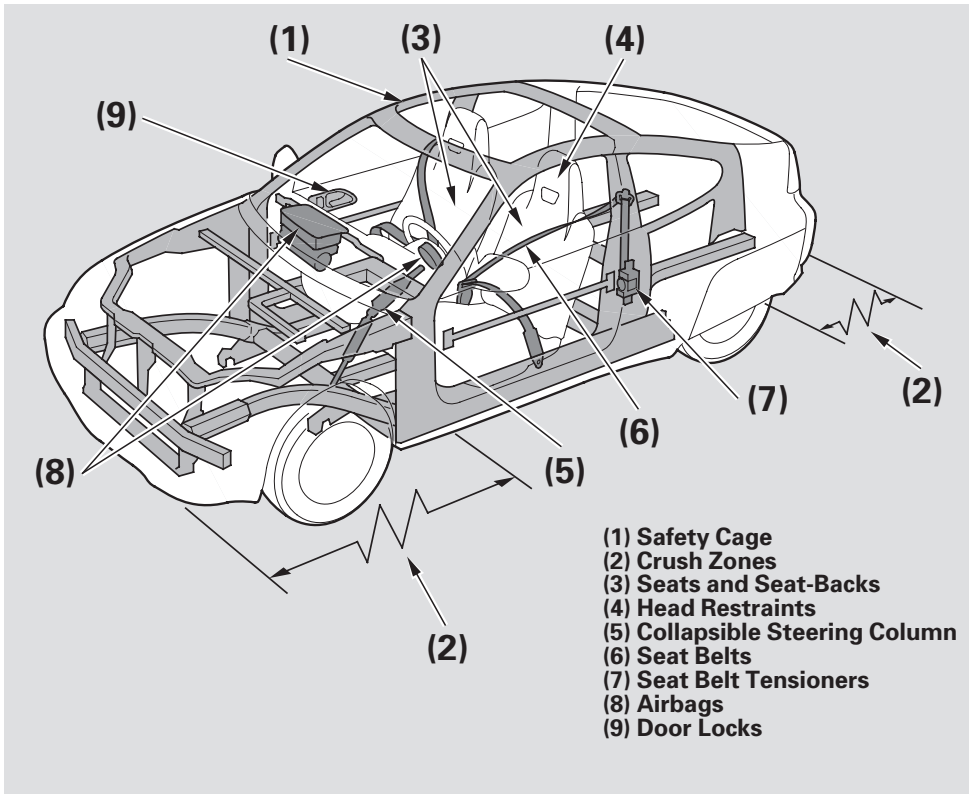

Your vehicle is equipped with many features that work together to protect you and your passenger during a crash.

Some features do not require any action on your part. These include a strong aluminum framework that forms a safety cage around the passenger compartment; front and rear crush zones, a collapsible steering column; and tensioners that tighten the seat belts in a crash.

However, you and your passenger can't take full advantage of these features unless you remain sitting in a proper position and ***always wear your seat belts***. In fact, some safety features can contribute to injuries if they are not used properly.

The following pages explain how you can take an active role in protecting yourself and your passenger.

Your Vehicle's Safety Features

Seat Belts

Your vehicle is equipped with seat belts in both seating positions.

Your seat belt system also includes an indicator on the instrument panel to remind you and your passenger to fasten your seat belts.

Why Wear Seat Belts

Seat belts have proven to be the single most effective safety device for adults and larger children.

Not wearing a seat belt properly increases the chance of serious injury or death in a crash, even though your vehicle has airbags.

In addition, most states and all Canadian provinces require you to wear seat belts.

WARNING

Not wearing a seat belt properly increases the chance of serious injury or death in a crash, even though your vehicle has airbags.

Be sure you and your passenger always wear seat belts and wear them properly.

When properly worn, seat belts:

- Keep you connected to the vehicle so you can take advantage of the vehicle's built-in safety features.
- Help protect you in almost every type of crash, including frontal, side, and rear impacts and rollovers.

- Help keep you from being thrown against the inside of the vehicle and against the other occupant.
- Keep you from being thrown out of the vehicle.
- Help keep you in a good position should the airbags ever deploy. A good position reduces the risk of injury from an inflating airbag and allows you to get the best advantage from the airbag.

Of course, seat belts cannot completely protect you in every crash. But in most cases, seat belts can reduce your risk of serious injury.

What you should do: Always wear your seat belt, and make sure you wear it properly.

Airbags

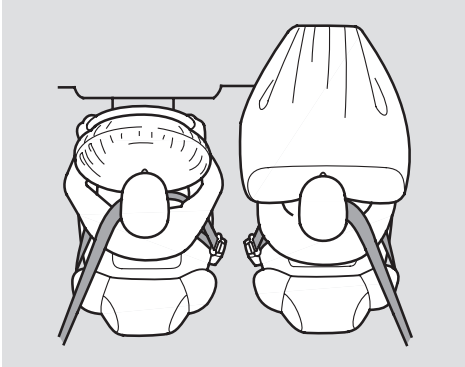

Your vehicle has a Supplemental Restraint System (SRS) with front airbags to help protect the heads and chests of the driver and a passenger during a moderate to severe frontal collision (see page 21 for more information on how your airbags work).

The most important things you need to know about your airbags are:

- ***Airbags do not replace seat belts.*** They are designed to supplement the seat belts.
- ***Front airbags offer no protection in side impacts, rear impacts, rollovers, or minor collisions.***
- ***Airbags can pose serious hazards.*** To do their job, airbags must inflate with tremendous force. So while airbags help save lives, they can cause minor injuries or more serious or even fatal injuries if occupants are not properly restrained or sitting properly.

What you should do: Always wear your seat belt properly, and sit upright and as far back from the steering wheel as possible while allowing full control of the vehicle. A passenger should move the seat as far back from the dashboard as possible.

The rest of this section gives more detailed information about how you can maximize your safety.

Remember, however, that no safety system can prevent all injuries or deaths that can occur in a severe crash, even when seat belts are properly worn and the airbags deploy.

Protecting Adults and Teens

Introduction

The following pages provide instructions on how to properly protect the driver, an adult passenger or teenage child large enough and mature enough to drive or ride in your vehicle. See pages [25](#) – [37](#) for important guidelines on how to properly protect a small or larger child.

1. Close and Lock the Doors

After everyone has entered the vehicle, be sure the doors are closed and locked.



Your vehicle has a door monitor indicator on the instrument panel to indicate when either door or the hatch is not tightly closed.

Locking the doors reduces the chance of someone being thrown out of the vehicle during a crash, and it helps prevent a passenger from accidentally opening a door and falling out.

Locking the doors also helps prevent an outsider from unexpectedly opening a door when you come to a stop.

See page [62](#) for how to lock the doors, and page [46](#) for how the monitor indicator works.

2. Adjust the Seats

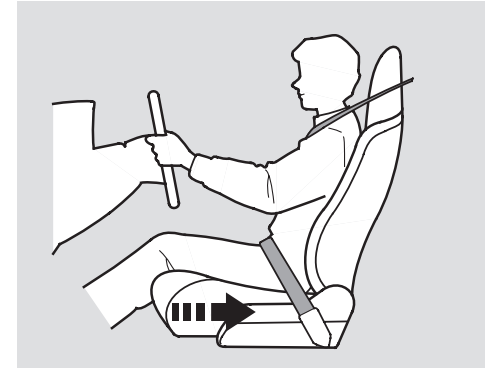

Adjust the driver's seat as far to the rear as possible while allowing you to maintain full control of the vehicle. Have a passenger adjust his or her seat as far to the rear as possible.

If you sit too close to the steering wheel or dashboard, you can be seriously injured by an inflating airbag, or by striking the steering wheel or dashboard.

The National Highway Traffic Safety Administration and Transport Canada recommend that drivers allow at least 10 inches (25 cm) between the center of the steering wheel and the chest.

If you cannot get far enough away from the steering wheel and still reach the controls, we recommend that you investigate whether some type of adaptive equipment may help.

Once your seat is adjusted correctly, rock it back and forth to make sure the seat is locked in position.

See page [66](#) for how to adjust the seats.

⚠ WARNING

Sitting too close to a front airbag can result in serious injury or death if the front airbags inflate.

Always sit as far back from the front airbags as possible.

3. Adjust the Seat-Backs

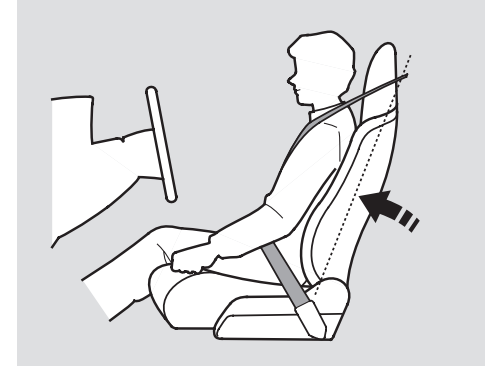

Adjust the driver's seat-back to a comfortable, upright position, leaving ample space between your chest and the airbag cover in the center of the steering wheel.

A passenger should also adjust their seat-back to a comfortable, upright position.

CONTINUED

Protecting Adults and Teens

Reclining a seat-back so that the shoulder part of the belt no longer rests against the occupant's chest reduces the protective capability of the belt. It also increases the chance of sliding under the belt in a crash and being seriously injured. The farther a seat-back is reclined, the greater the risk of injury.

See page 66 for how to adjust the seat-backs.

⚠ WARNING

Reclining the seat-back too far can result in serious injury or death in a crash.

Adjust the seat-back to an upright position, and sit well back in the seat.

4. Fasten and Position the Seat Belts

Insert the latch plate into the buckle, then tug on the belt to make sure the belt is securely latched. Check that the belt is not twisted, because a twisted belt can cause serious injuries in a crash.



Position the lap part of the belt as low as possible across your hips, then pull up on the shoulder part of the belt so the lap part fits snugly. This lets your strong pelvic bones take the force of a crash and reduces the chance of internal injuries.

If necessary, pull up on the belt again to remove any slack, then check that the belt rests across the center of your chest and over your shoulder. This spreads the forces of a crash over the strongest bones in your upper body.

Never place the shoulder portion of a lap/shoulder belt under your arm or behind your back. This could cause very serious injuries in a crash.

WARNING

Improperly positioning the seat belts can cause serious injury or death in a crash.

Make sure all seat belts are properly positioned before driving.

If a seat belt does not seem to work properly, it may not protect the occupant in a crash.

No one should sit in a seat with an inoperative seat belt. Using a seat belt that is not working properly can result in serious injury or death. Have your dealer check the belt as soon as possible.

See page 18 for additional information about your seat belts and how to take care of them.

5. Maintain a Proper Sitting Position

After occupants have adjusted their seats and put on seat belts, it is very important that they continue to sit upright, well back in their seats, with their feet on the floor, until the vehicle is parked and the engine is off.

Sitting improperly can increase the chance of injury during a crash. For example, if an occupant slouches, lies down, turns sideways, sits forward, leans forward or sideways, or puts one or both feet up, the chance of injury during a crash is greatly increased.

CONTINUED

Protecting Adults and Teens

In addition, an occupant who is out of position can be seriously or fatally injured in a crash by striking interior parts of the vehicle or being struck by an inflating front airbag.

⚠️ WARNING

Sitting improperly or out of position can result in serious injury or death.

Always sit upright, well back in the seat, with your feet on the floor.

Advice for Pregnant Women



If you are pregnant, the best way to protect yourself and your unborn child when driving or riding in a vehicle is to always wear a seat belt, and keep the lap part of the belt as low as possible across the hips.

When driving, remember to sit upright and adjust the seat as far back as possible while allowing full control of the vehicle. When riding as a passenger, adjust the seat as far back as possible.

This will reduce the risk of injuries to both you and your unborn child that can be caused by a crash or an inflating front airbag.

Each time you have a checkup, ask your doctor if it's okay for you to drive.

Additional Safety Precautions

- ***Two people should never use the same seat belt.*** If they do, they could be very seriously injured in a crash.
- ***Do not put any accessories on seat belts.*** Devices intended to improve occupant comfort or reposition the shoulder part of a seat belt can reduce the protective capability of the belt and increase the chance of serious injury in a crash.
- ***Do not place hard or sharp objects between yourself and a front airbag.*** Carrying hard or sharp objects on your lap, or driving with a pipe or other sharp object in your mouth, can result in injuries if your front airbag inflates.
- ***Do not attach or place objects on the front airbag covers.*** Objects on the covers marked “SRS AIRBAG” could interfere with the proper operation of the airbags or be propelled inside the vehicle and hurt someone if the airbags inflate.
- ***Keep your hands and arms away from the airbag covers.*** If your hands or arms are close to an airbag cover, they could be injured if the airbag inflates.

Additional Information About Your Seat Belts

Seat Belt System Components

Your seat belt system includes lap/shoulder belts in both seating positions. These belts are equipped with automatic seat belt tensioners.



The seat belt system includes an indicator on the instrument panel and a beeper to remind you to fasten your seat belt.

If you turn the ignition switch to ON (II) before fastening your seat belt, the beeper will sound, and the indicator will flash. If you do not fasten your seat belt before the beeper stops, the indicator will stop flashing but remain on.

If you continue driving without fastening your seat belt, the beeper will sound and the indicator will flash again at regular intervals.

Lap/Shoulder Belt

The lap and shoulder belt goes over your shoulder, across your chest, and across your hips.

To fasten the belt, insert the latch plate into the buckle, then tug on the belt to make sure the buckle is latched (see page 14 for how to properly position the belt).

To unlock the belt, push the red PRESS button on the buckle. Guide the belt across your body so that it retracts completely. After exiting the vehicle, be sure the belt is out of the way and will not get closed in the door.

Both seat belts have an emergency retractor. In normal driving, the retractor lets you move freely in your seat while it keeps some tension on the belt. During a collision or sudden stop, the retractor automatically locks the belt to help restrain your body.

The passenger's seat belt has an additional locking mechanism that must be activated to secure a forward-facing child seat (see page 31).

If the shoulder part of the belt is pulled all the way out, the locking mechanism will activate. The belt will retract, but it will not allow the passenger to move freely.

To deactivate the locking mechanism, unlatch the buckle and let the seat belt fully retract. To refasten the seat belt, pull it out only as far as needed.

Additional Information About Your Seat Belts

Automatic Seat Belt Tensioners



For added protection, the seat belts are equipped with automatic seat belt tensioners. When activated, the tensioners immediately tighten the belts to help hold the driver and a passenger in place.

The tensioners are designed to activate primarily in frontal collisions, and they should activate in any collision severe enough to cause airbag inflation.

However, the tensioners can be activated during a collision in which the front airbags do not deploy. In this case, the airbags would not be needed, but the additional restraint could be helpful.

When the tensioners are activated, the seat belts will remain tight until they are unbuckled in the normal manner.

Seat Belt Maintenance

For safety, you should check the condition of your seat belts regularly.

Pull each belt out fully and look for frays, cuts, burns, and wear. Check that the latches work smoothly and the belts retract easily. Any belt that is not in good condition or not working properly will not provide good protection and should be replaced as soon as possible.

Honda provides a lifetime warranty on seat belts for U.S. models. See your *Honda Warranty Information* booklet for details.

If a seat belt is worn during a crash, it must be replaced by your dealer. A belt that has been worn during a crash may not provide the same level of protection in a subsequent crash.

CONTINUED

Additional Information About Your Seat Belts

The dealer should also inspect the anchors for damage and replace them if needed. If the automatic seat belt tensioners activate during a crash, they must be replaced.

For information on how to clean your seat belts, see page [151](#) .

WARNING

Not checking or maintaining seat belts can result in serious injury or death if the seat belts do not work properly when needed.

Check your seat belts regularly and have any problem corrected as soon as possible.

Additional Information About Your Airbags

Airbag System Components

Your airbag system includes:

- Two SRS (Supplemental Restraint System) front airbags. The driver's airbag is stored in the center of the steering wheel; the passenger's airbag is stored in the dashboard. Both are marked "SRS AIRBAG."
- Automatic seat belt tensioners (see page 19).
- Sensors that can detect a moderate to severe frontal collision.
- A sophisticated electronic system that continually monitors and records information about the sensors, the control unit, and the airbag activators when the ignition switch is in the ON (II) position.

- An indicator on the instrument panel that alerts you to a possible problem with your airbags, sensors, or seat belt tensioners (see page 23).
- Emergency backup power in case your vehicle's electrical system is disconnected in a crash.

How Your Front Airbags Work

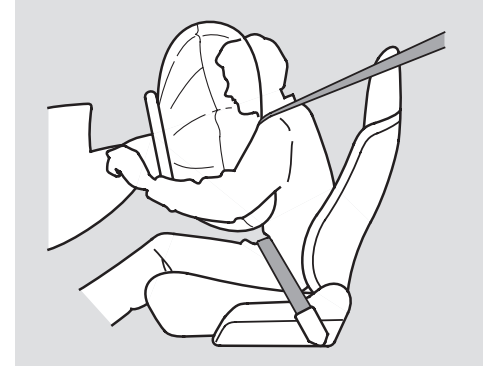

If you ever have a moderate to severe frontal collision, sensors will detect the vehicle's rapid deceleration.

If the rate of deceleration is high enough, the control unit will instantly inflate the driver's and passenger's front airbags.

CONTINUED

Additional Information About Your Airbags

During a frontal crash, your seat belt restrains your lower body and torso, and the airbag helps protect your head and chest.

Although both airbags normally inflate within a split second of each other, it is possible for only one airbag to deploy.

This can happen if the severity of a collision is at the margin, or threshold, that determines whether or not the airbags will deploy. In such cases, the seat belt will provide sufficient protection, and the supplemental protection offered by the airbag would be minimal.

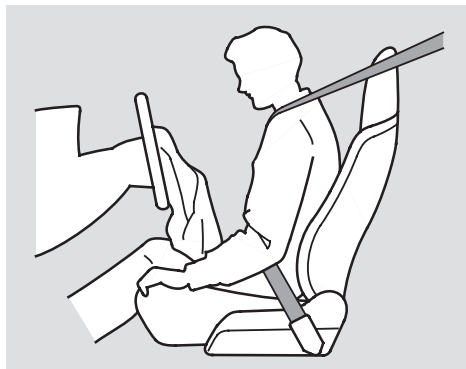

After inflating, the front airbags will immediately deflate, so they won't interfere with the driver's visibility, or the ability to steer or operate other controls.

The total time for inflation and deflation is one-tenth of a second, so fast that most occupants are not aware that the airbags deployed until they see them lying in their laps.

After a crash, you may see what looks like smoke. This is actually powder from the airbag's surface. Although the powder is not harmful, people with respiratory problems may experience some temporary discomfort. If this occurs, get out of the vehicle as soon as it is safe to do so.

How the SRS Indicator Works



The SRS indicator alerts you to a potential problem with your airbags or seat belt tensioners (see page 19).

When you turn the ignition switch to ON (II), this indicator will come on briefly then go out. This tells you the system is working properly.

If the indicator comes on at any other time, or does not come on at all, you should have the system checked by your dealer. For example:

- If the SRS indicator does not come on after you turn the ignition switch to ON (II).
- If the indicator stays on after the engine starts.
- If the indicator comes on or flashes on and off while you drive.

If you see any of these indications, the airbags and seat belt tensioners may not work properly when you need them.

⚠ WARNING

Ignoring the SRS indicator can result in serious injury or death if the airbag systems or tensioners do not work properly.

Have your vehicle checked by a dealer as soon as possible if the SRS indicator alerts you to a possible problem.

Airbag Service

Your airbag system is virtually maintenance-free, and there are no parts you can safely service. However, you must have your vehicle serviced if:

- ***An airbag ever inflates.*** Any airbag that has deployed must be replaced, along with the control unit and seat belt tensioner. Do not try to remove or replace any airbag by yourself. This must be done by your dealer or a knowledgeable body shop.
- ***The SRS indicator alerts you to a problem.*** Take your vehicle to an authorized dealer as soon as possible. If you ignore this indication, your airbags may not operate properly.

Additional Information About Your Airbags

Additional Safety Precautions

- ***Do not attempt to deactivate your airbags.*** Together, airbags and seat belts provide the best protection.
- ***Do not tamper with airbag components or wiring for any reason.*** Tampering could cause the airbags to deploy, possibly causing very serious injury.

Children depend on adults to protect them. However, despite their best intentions, many adults do not know how to *properly* protect child passengers.

If you ever need to drive with a child in your vehicle, be sure to read this section. It begins with important general guidelines, then presents special information for infants, small children and larger children.

All Children Must Be Restrained
Each year, many children are injured or killed in vehicle crashes because they are either unrestrained or not properly restrained. In fact, vehicle accidents are the number one cause of the death of children ages 12 and under.

To reduce the number of child deaths and injuries, every state and Canadian province requires that infants and children be properly restrained when they ride in a vehicle.

Any child who is too small to wear a seat belt must be restrained in an approved child seat that is properly secured to the vehicle (see pages 30 – 32).

A larger child must be restrained with a lap/shoulder belt and ride on a booster seat until the seat belt fits him or her properly (see pages 34 – 37).

WARNING

Children who are unrestrained or improperly restrained can be seriously injured or killed in a crash.

Any child too small for a seat belt should be properly restrained in a child seat. A larger child should be properly restrained with a seat belt and use a booster seat if necessary.

Protecting Children – General Guidelines

Your Vehicle is Not Recommended for Child Passengers

The National Highway Traffic Safety Administration and Transport Canada recommend that all children age 12 and under be properly restrained in a back seat.

Since this vehicle does not have a back seat, we strongly recommend that you do not carry any child who is not large enough or mature enough to ride in front (see page [36](#)).

The Passenger's Front Airbag Poses Serious Risks

Front airbags have been designed to help protect adults in a moderate to severe frontal collision. To do this, the passenger's airbag is quite large, and it can inflate with enough force to cause very serious injuries.

Infants

Never put a rear-facing child seat in this vehicle. If the airbag inflates, it can hit the back of the child seat with enough force to kill or very seriously injure an infant.

Small Children

Placing a forward-facing child seat in the passenger's seat can be hazardous. If the vehicle seat is too far forward, or the child's head is thrown forward during a collision, an inflating front airbag can strike the child with enough force to kill or very seriously injure a small child.

Larger Children

Children who have outgrown child seats are also at risk of being injured or killed by an inflating passenger's front airbag. If a larger child must ride in this vehicle, see page [36](#) for important guidelines on how to decide when a child is ready to ride in front and how to properly protect the child.

Protecting Children – General Guidelines

To remind you of the passenger's airbag hazards, your vehicle has warning labels on the dashboard (U.S. models) and on the driver's and passenger's visors. Please read and follow the instructions on these labels.

U.S. Models Sun Visor

 WARNING	
	<p>DEATH or SERIOUS INJURY can occur</p> <ul style="list-style-type: none">• Children 12 and under can be killed by the air bag• NEVER put a rear-facing child seat in the front• Sit as far back as possible from the air bag• ALWAYS use SEAT BELTS and CHILD RESTRAINTS

Canadian Models Sun Visor

<p>CAUTION TO AVOID SERIOUS INJURY:</p> <ul style="list-style-type: none">• FOR MAXIMUM SAFETY PROTECTION IN ALL TYPES OF CRASHES, YOU MUST ALWAYS WEAR YOUR SAFETY BELT.• DO NOT INSTALL REARWARD-FACING CHILD SEATS IN ANY FRONT PASSENGER SEAT POSITION.• DO NOT SIT OR LEAN UNNECESSARILY CLOSE TO THE AIR BAG.• DO NOT PLACE ANY OBJECTS OVER THE AIR BAG OR BETWEEN THE AIR BAG AND YOURSELF.• SEE THE OWNER'S MANUAL FOR FURTHER INFORMATION AND EXPLANATIONS.	<p>PRÉCAUTIONS:</p> <p>POUR ÉVITER DES BLESSURES GRAVES:</p> <ul style="list-style-type: none">• POUR PROFITER D'UNE PROTECTION MAXIMALE LORS D'UNE COLLISION, BOUCLEZ TOUJOURS VOTRE CEINTURE DE SÉCURITÉ.• N'INSTALLEZ JAMAIS UN SIÈGE POUR ENFANTS FAISANT FACE À L'ARRIÈRE SUR LE SIÈGE DU PASSAGER AVANT.• NE VOUS APPUYEZ PAS ET NE VOUS ASSOYEZ PAS PRÈS DU COUSSIN GONFLABLE.• NE DÉPOSEZ AUCUN OBJET SUR LE COUSSIN GONFLABLE OU ENTRE LE COUSSIN GONFLABLE ET VOUS.• LISEZ LE GUIDE UTILISATEUR POUR DE PLUS AMPLES RENSEIGNEMENTS.
---	---

Dashboard

 WARNING	
Children Can Be KILLED or INJURED by Passenger Air Bag	
• Make sure all children use seat belts or child seats.	
To be removed by owner only.	

Protecting Children – General Guidelines

Additional Safety Precautions

- **Never hold a small child on your lap.** If you are not wearing a seat belt in crash, you could be thrown forward and crush the child against the dashboard. If you are wearing a seat belt, the child can be torn from your arms and be seriously hurt or killed.
- **Never put a seat belt over yourself and a child.** During a crash, the belt could press deep into the child and cause serious or fatal injuries.
- **Never let two children use the same seat belt.** If they do, they could be very seriously injured in a crash.

- **Do not leave children alone in a vehicle.** Leaving children without adult supervision is illegal in most states and Canadian provinces, and can be very hazardous.

For example, a small child left in a vehicle on a hot day can die from heatstroke. A child left alone with the key in the ignition switch can accidentally set the vehicle in motion, possibly injuring themselves or others.

- **Lock both doors and the hatch when your vehicle is not in use.** Children who play in vehicles can accidentally get trapped inside. Teach your children not to play in or around vehicles.

- **Keep vehicle keys and remote transmitters out of the reach of children.** Even very young children learn how to unlock vehicle doors, turn on the ignition switch, and open the trunk, which can lead to accidental injury or death.

Because an inflating airbag can seriously injure or kill small children, we recommend that you do not carry a small child as a passenger in this vehicle.

If you decide to transport a small child in this vehicle, be sure to move the passenger seat as far to the rear as possible, and follow the instructions and guidelines in the following pages.



A child who is at least one year old and who fits within the child seat maker's weight and height limits, should be restrained in a forward-facing, upright child seat.

Of the different seats available, we recommend those that have a five-point harness system as shown.

We also recommend that a small child use the child seat as long as possible, until the child reaches the weight or height limit for the seat.

▲ WARNING

Placing a forward-facing child seat in the passenger's seat can result in serious injury or death if the airbag inflates.

If you must place a forward-facing child seat in the passenger's seat, move the vehicle seat as far back as possible and properly restrain the child.

Selecting a Child Seat, Installing a Child Seat

Selecting a Child Seat

To provide proper protection, a child seat should meet three requirements:

- 1. The child seat should meet U.S. or Canadian Motor Vehicle Safety Standard 213.** Look for FMVSS 213 or CMVSS 213 on the box.
- 2. The child seat should be of the proper type and size to fit the child.**
- 3. The child seat should fit the passenger's seat.**

Before purchasing a child seat, or using a previously purchased one, we recommend that you test the seat to make sure it fits properly in the passenger's seat.

Installing a Child Seat

After selecting a proper child seat, there are three main steps in installing a child seat:

- 1. Properly secure the child seat to the vehicle.** All child seats must be secured to the vehicle with the lap part of a lap/shoulder belt. A child whose seat is not properly secured to the vehicle can be endangered in a crash.
- 2. Make sure the child seat is firmly secured.** After installing a child seat, push and pull the seat forward and from side to side to verify that it is secure.

A child seat secured with a seat belt should be installed as firmly as possible. However, it does not need to be “rock solid.” Some side-to-side movement can be expected and should not reduce the child seat's effectiveness.

If the child seat is not secure, use a different style of child seat that can be firmly secured.

- 3. Secure the child in the child seat.** Make sure the child is properly strapped in the child seat according to the child seat maker's instructions. A child who is not properly secured in a child seat can be seriously injured in a crash.

The following pages provide guidelines on how to properly install a forward-facing child seat.

Installing a Child Seat

In this vehicle, a child seat must be secured to the vehicle with the lap part of the lap/shoulder belt. In addition, the passenger's lap/shoulder belt has a locking mechanism that must be activated to secure a child seat.

1. Move the vehicle seat to the rear-most position. Moving the seat as far back as possible reduces the chance of a child being injured or killed if the passenger's airbag inflates.



2. With the child seat in position, route the belt through the child seat according to the seat maker's instructions, then insert the latch plate into the buckle.
3. To activate the lockable retractor, slowly pull the shoulder part of the belt all the way out until it stops, then let the belt feed back into the retractor.



4. After the belt has retracted, tug on it. If the belt is locked, you will not be able to pull it out. If you can pull the belt out, it is not locked and you will need to repeat these steps.

CONTINUED

Installing a Child Seat



5. After confirming that the belt is locked, grab the shoulder part of the belt near the buckle and pull up to remove any slack from the lap part of the belt. Remember, if the lap part of the belt is not tight, the child seat will not be secure.

To remove slack, it may help to put weight on the child seat, or push on the back of the seat while pulling up on the belt.



6. Push and pull the child seat forward and from side to side to verify that it is secure enough to stay upright during normal driving maneuvers. If the child seat is not secure, unlatch the belt, allow it to retract fully, then repeat these steps.

To deactivate the locking mechanism and remove a child seat, unlatch the buckle, unrout the seat belt, and let the belt fully retract.

Installing a Child Seat with a Tether

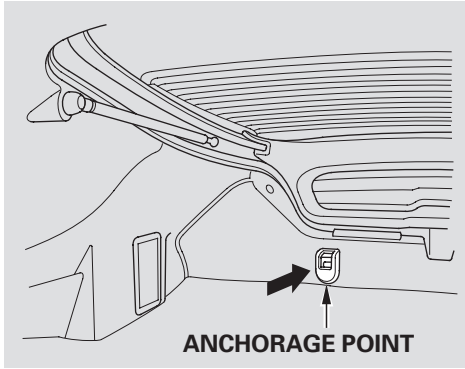

A child seat with a tether can be installed in the passenger's seat, using the anchorage point shown above.

Since a tether can provide additional security to the lap/shoulder belt installation, we recommend using a tether whenever one is required or available.

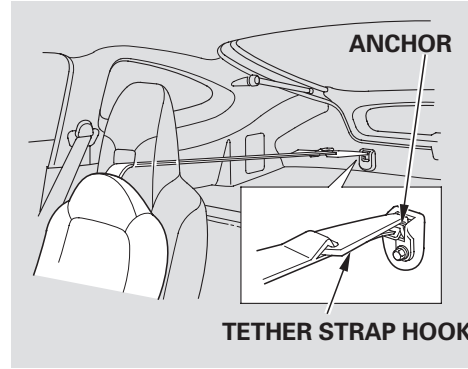

1. After properly securing the child seat with the lap/shoulder belt (see page 31), route the tether strap through the hole of the seat-back.
2. Attach the tether strap hook to the anchor, making sure the strap is not twisted, then tighten the strap according to the seat maker's instructions.

Protecting Larger Children

When a child reaches the recommended weight or height limit for a forward-facing child seat, the child should sit in a back seat on a booster seat and wear a lap/shoulder belt.

Since this vehicle does not have a back seat, we recommend that you do not carry a larger child, age 12 or under, as a passenger.

However, the following pages provide guidelines to help you decide when a given child may ride in this vehicle, and how to properly protect the child.

⚠ WARNING

Allowing a larger child age 12 or under to ride in the vehicle can result in injury or death if the passenger's front airbag inflates.

If a larger child must ride in the vehicle, move the vehicle seat as far back as possible, use a booster seat if needed, have the child sit up properly and wear the seat belt properly.

Checking Seat Belt Fit

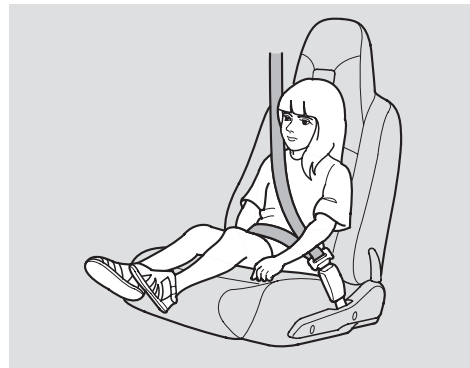

To determine if a lap/shoulder belt properly fits a child, have the child put on the seat belt, then ask yourself:

1. Does the child sit all the way back against the seat?
2. Do the child's knees bend comfortably over the edge of the seat?

3. Does the shoulder belt cross between the child's neck and arm?
4. Is the lap part of the belt as low as possible, touching the child's thighs?
5. Will the child be able to stay seated like this for the whole trip?

If you answer yes to all these questions, the child is ready to wear the lap/shoulder belt correctly. If you answer no to any question, the child needs to ride on a booster seat.

Using a Booster Seat



A child who has outgrown a forward-facing child seat should use a booster seat until the lap/shoulder belt fits them properly without the booster.

Some states and Canadian provinces also require children to use a booster seat until they reach a given age or weight (e.g., 6 years or 60 lbs). Be sure to check current laws in the states or provinces where you intend

to drive.

Booster seats can be high-back or low-back. Whichever style you select, make sure the booster meets federal safety standards and that you follow the booster seat maker's instructions.

If a child who uses a booster seat rides in this vehicle, move the vehicle seat as far to the rear as possible, and be sure the child is wearing the seat belt properly.

A child may continue using a booster seat until the tops of their ears are even with the top of the vehicle's or booster's seat-back. A child of this height should be tall enough to use the lap/shoulder belt without a booster seat.

Protecting Larger Children

When Can a Larger Child Ride in This Vehicle

As noted earlier, the National Highway Traffic Safety Administration and Transport Canada recommend that all children age 12 and under ride properly restrained in a back seat.

If the passenger's front airbag inflates in a moderate to severe frontal collision, the airbag can cause serious injuries to a child who is unrestrained, improperly restrained, sitting too close to the airbag, or out of position.

Of course, children vary widely. And while age may be one indicator of when a child can safely ride in front, there are other important factors you should consider.

Physical Size

Physically, a child must be large enough for the lap/shoulder belt to properly fit (see page 34). If the seat belt does not fit properly, with or without the child sitting on a booster, the child should not sit in this vehicle.

Maturity

To safely ride in this vehicle, a child must be able to follow the rules, including sitting properly, and wearing the seat belt properly throughout ride.

If you decide that a child can safely ride in this vehicle, be sure to:

- Carefully read the owner's manual, and make sure you understand all seat belt instructions and all safety information.
- Move the vehicle seat to the rear-most position.
- Have the child sit up straight, back against the seat, and feet on or near the floor.
- Check that the child's seat belt is properly and securely positioned.
- Supervise the child. Even mature children sometimes need to be reminded to fasten the seat belts or sit properly.

Additional Safety Precautions

Do not let a child wear a seat belt across the neck. This could result in serious neck injuries during a crash.

Do not let a child put the shoulder part of a seat belt behind the back or under the arm. This could cause very serious injuries during a crash. It also increases the chance that the child will slide under the belt in a crash and be injured.

Two children should never use the same seat belt. If they do, they could be very seriously injured in a crash.

Do not put any accessories on a seat belt. Devices intended to improve a child's comfort or reposition the shoulder part of a seat belt can make the belt less effective and increase the chance of serious injury in a crash.

Carbon Monoxide Hazard

Your vehicle's exhaust contains carbon monoxide gas. You should have no problem with carbon monoxide entering the vehicle in normal driving if you maintain your vehicle properly.

Have the exhaust system inspected for leaks whenever:

- The vehicle is raised for an oil change.
- You notice a change in the sound of the exhaust.
- The vehicle was in an accident that may have damaged the underside.

WARNING

Carbon monoxide gas is toxic. Breathing it can cause unconsciousness and even kill you.

Avoid any enclosed areas or activities that expose you to carbon monoxide.

High levels of carbon monoxide can collect rapidly in enclosed areas, such as a garage. Do not run the engine with the garage door closed. Even with the door open, run the engine only long enough to move the vehicle out of the garage.

With the hatch open, airflow can pull exhaust gas into your vehicle's interior and create a hazardous condition. If you must drive with the hatch open, open all the windows, and set the heating/climate control system as shown below.

If you must sit in your parked vehicle, even in an unconfined area, with the engine running, adjust the heating/climate control system as follows:

1. Select the fresh air mode.
2. Select the  mode.
3. Turn the fan on high speed.
4. Set the temperature control to a comfortable setting.

This section gives information about the controls and displays that contribute to the daily operation of your vehicle. All the essential controls are within easy reach.

Control Locations	42	Immobilizer System.....	60
Instrument Panel	43	Ignition Switch	61
Instrument Panel Indicators.....	44	Door Locks.....	62
Gauges	48	Hatch.....	63
Fuel Gauge	49	Remote Transmitter.....	64
Temperature Gauge	49	Seats	66
Odometer.....	49	Power Windows	67
Display Change Button.....	49	Mirrors.....	68
Current Fuel Mileage.....	50	Parking Brake	69
Trip Meters	50	Interior Convenience Items.....	70
Trip Mileage.....	50	Storage Box.....	71
Segment Distance and Fuel		Beverage Holder.....	71
Mileage	51	Glove Box	71
Lifetime Fuel Mileage.....	51	Accessory Power Socket	71
Turning Off the Mileage		Interior Lights.....	72
Displays.....	52		
Battery Level Gauge	53		
Charge/Assist Gauge	53		
Controls Near the Steering			
Wheel.....	54		
Windshield Wipers and Washers ..	55		
Turn Signal and Headlights.....	56		
Instrument Panel Brightness	57		
Hazard Warning Button.....	57		
Rear Window Defogger	58		
Keys and Locks.....	59		

Control Locations

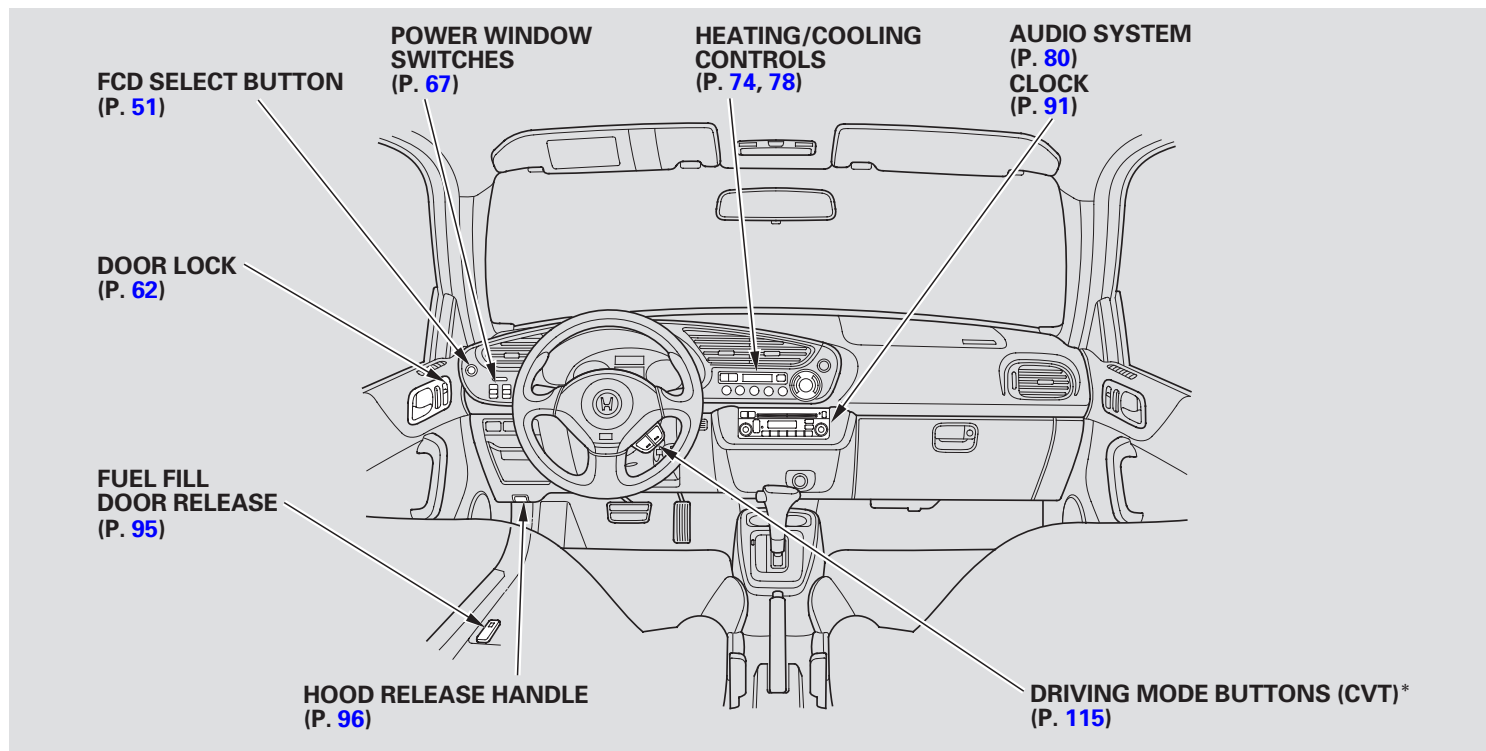

* U.S. model

Manual Transmission shown

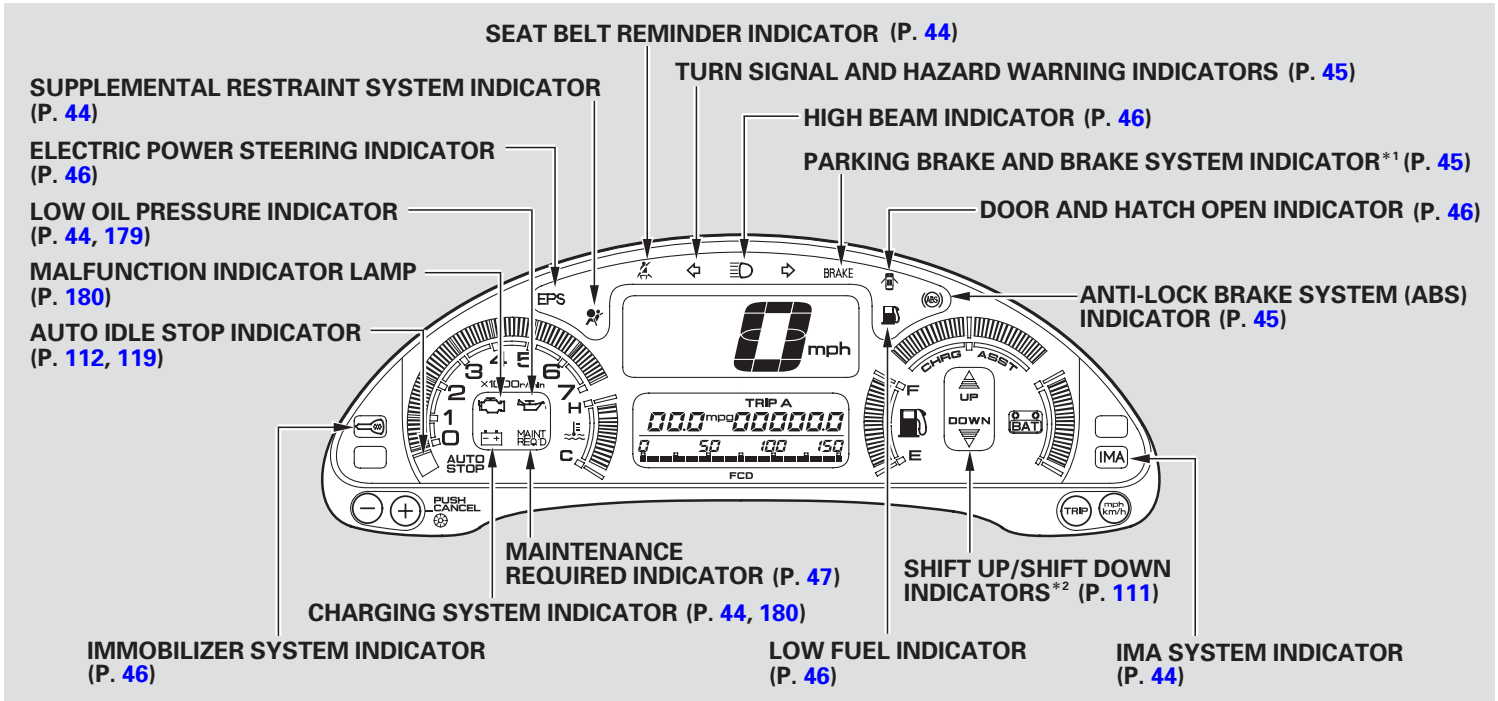

* 1 : The U.S. instrument panel is shown. Differences for the Canadian models are noted in the text.

* 2 : Shift Lever Position Indicators on CVT model (P. 113)

Instrument Panel Indicators

The instrument panel has many indicators to give you important information about your vehicle.



Seat Belt Reminder Indicator

This indicator comes on when you turn the ignition switch to ON (II). It reminds you and your passenger to fasten your seat belts. A beeper also sounds if you have not fastened your seat belt.

If you turn the ignition switch to ON (II) before fastening your seat belt, the beeper sounds and the indicator flashes. If you do not fasten your seat belt before the beeper stops, the indicator stops flashing but remains on.

If you continue driving without fastening your seat belt, the beeper sounds and the indicator flashes again at regular intervals.



Low Oil Pressure Indicator

The engine can be severely damaged if this indicator flashes or stays on when the engine is running. For more information, see page [179](#).



Charging System Indicator

If this indicator comes on when the engine is running, the battery is not being charged. For more information, see page [180](#).



Supplemental Restraint System Indicator

This indicator comes on when you turn the ignition switch to ON (II). If it comes on at any other time, it indicates a potential problem with your front airbags or automatic seat belt tensioners. For more information, see page [23](#).



IMA System Indicator

This indicator normally comes on for a few seconds when you turn the ignition switch to ON (II). If it comes on at any other time, it indicates a problem in the Integrated Motor Assist (IMA) system. Have the vehicle checked by the dealer as soon as possible.

Shift Up/Shift Down Indicators (Manual Transmission)

See page [111](#).

Shift Lever Position Indicators (Automatic Transmission)

See page [113](#).

Auto Idle Stop Indicator

See pages [112](#) and [119](#).

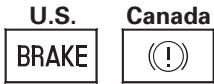

Parking Brake and Brake System Indicator

This indicator has two functions:

1. It comes on when you turn the ignition switch to ON (II). It is a reminder to check the parking brake. Driving with the parking brake not fully released can damage the brakes and tires.
2. If it remains lit after you fully release the parking brake while the engine is running, or if it comes on while driving, there could be a problem with the brake system. For more information, see page [182](#).



Malfunction Indicator Lamp

See page [180](#).



Turn Signal and Hazard Warning Indicators

The left or right turn signal indicator blinks when you signal a lane change or turn. If the indicator does not blink or blinks rapidly, it usually means one of the turn signal bulbs is burned out (see page [148](#)). Replace the bulb as soon as possible, since other drivers cannot see that you are signaling.

When you press the hazard warning button, both turn signal indicators blink. All turn signals on the outside of the vehicle should flash.



Anti-lock Brake System (ABS) Indicator

This indicator normally comes on for a few seconds when you turn the ignition switch to ON (II), and when the ignition switch is turned to START (III). If it comes on at any other time, there is a problem with the ABS. If this happens, have your vehicle checked at a dealer. With this indicator on, your vehicle still has normal braking ability but no anti-lock function. For more information, see page [122](#).

Instrument Panel Indicators



High Beam Indicator

This indicator comes on with the high beam headlights. For more information, see page 56 .

On Canadian models, this indicator comes on with reduced brightness when the Daytime Running Lights (DRL) are on (see page 56).



“Daytime Running Lights” Indicator

Canadian models only

This indicator comes on when you turn the ignition switch to ON (II) with the headlight switch off and the parking brake set. It should go off if you turn on the headlights or release the parking brake. If it comes on at any other time, it means there is a problem with the DRL. There may also be a problem with the high beam headlights.



Immobilizer System Indicator

This indicator comes on for a few seconds when you turn the ignition switch to ON (II). It will then go off if you have inserted a properly-coded ignition key. If it is not a properly-coded key, the indicator will blink, and the engine will not start (see page 60).

This indicator also blinks several times when you turn the ignition switch from ON (II) to ACCESSORY (I) or LOCK (0).



Door and Hatch Open Indicator

This indicator comes on if either door or the hatch is not closed tightly.



Low Fuel Indicator

This indicator comes on as a reminder that you must refuel soon.



Electric Power Steering (EPS) Indicator

This indicator normally comes on when you turn the ignition switch to ON (II) and goes off after the engine starts. If it comes on at any other time, there is a problem in the electric power steering system. If this happens, stop the vehicle in a safe place, and turn off the engine. Reset the system by restarting the engine, and watch the EPS indicator. If it does not go off, or comes back on again while driving, take the vehicle to your dealer to have it checked. With the indicator on, the EPS is turned off, making the vehicle harder to steer.

**MAINT
REQ'D**

Maintenance Required Indicator

This indicator reminds you that it is time to take your vehicle in for scheduled maintenance.

Refer to the maintenance schedule for normal and severe driving conditions on pages [129](#) and [130](#).

When the distance driven since the last scheduled maintenance reaches 6,000 miles (9,600 km), the indicator starts blinking. If you exceed 7,500 miles (12,000 km), the indicator stays on.

Your dealer will reset this indicator after completing the scheduled maintenance. If this maintenance is done by someone other than your dealer, reset the indicator as follows.

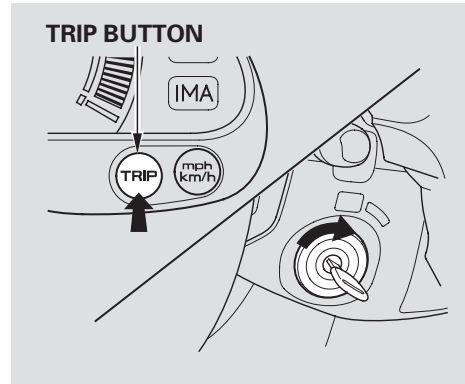

1. Turn off the engine.
2. Press and hold the TRIP button in the instrument panel, then turn the ignition switch to ON (II).
3. Hold the button for about 10 seconds until the indicator goes off.

Gauges

Manual Transmission shown

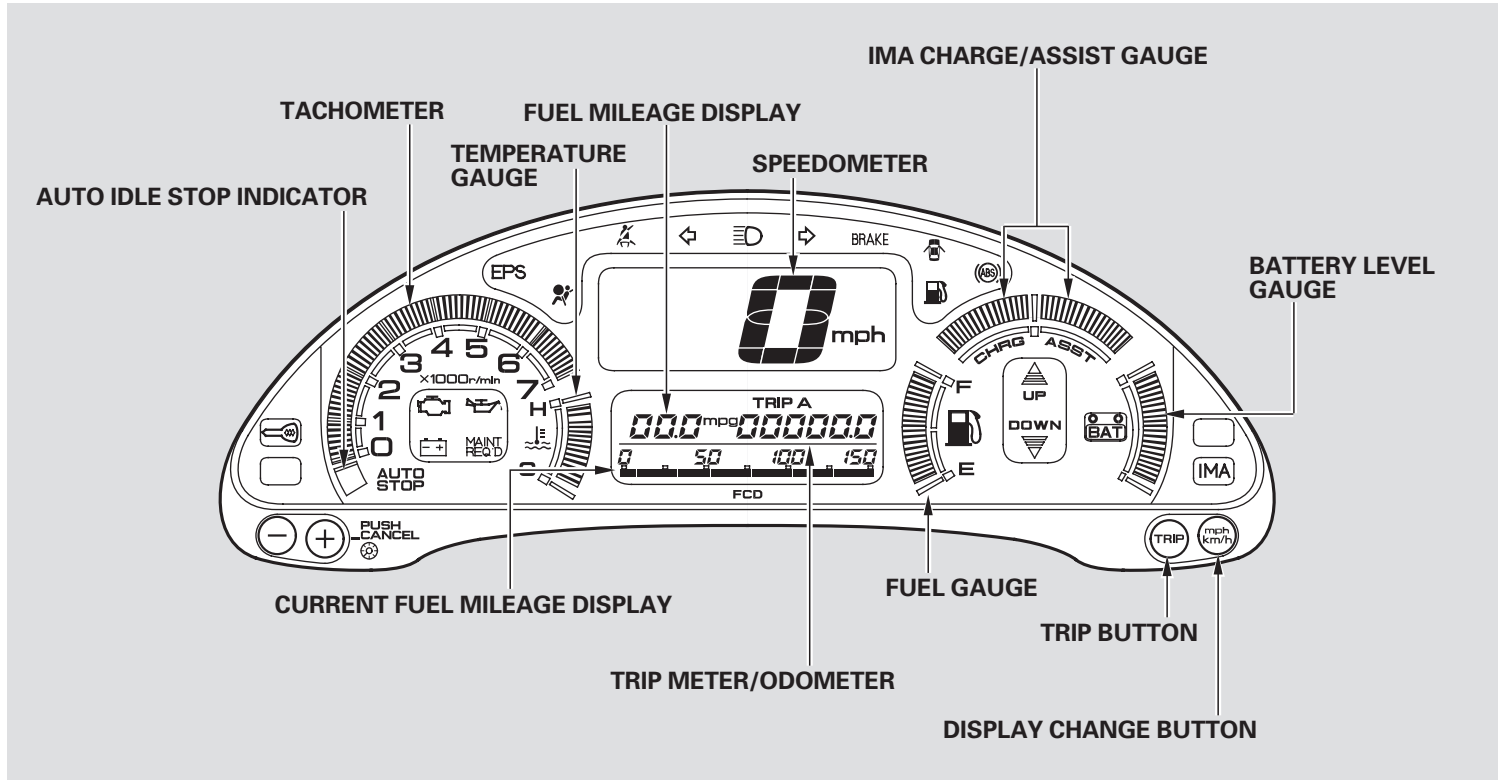

Fuel Gauge

This shows how much fuel you have. It may show slightly more or less than the actual amount.

NOTICE

Avoid driving with an extremely low fuel level. Running out of fuel could cause the engine to misfire, damaging the catalytic converter.

Temperature Gauge

This shows the temperature of the engine's coolant. During normal operation, the reading should be in the middle of the gauge. In severe driving conditions, the reading may reach near the red mark. If it reaches the red mark, pull safely to the side of the road. Turn to page [177](#) for instructions and precautions on checking the engine's cooling system.

Odometer

The odometer shows the total distance your vehicle has been driven. It measures miles in U.S. models and kilometers in Canadian models. It is illegal under U.S. federal law and Canadian provincial regulations to disconnect, reset, or alter the odometer with the intent to change the number of miles or kilometers indicated.

Display Change Button

Push the Display Change button to switch the speedometer, trip meter, and odometer reading between miles per hour and kilometers per hour.

Gauges

Current Fuel Mileage

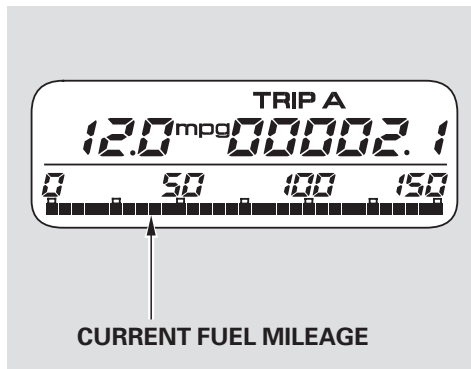

This display shows the current, or instantaneous fuel mileage you are getting. (U.S.: miles per hour and mpg, Canada: kilometer per hour and l/100 km)

You can turn off this display at any time. See page [52](#) .

Trip Meters

The trip meters show the number of miles or kilometers driven since you last reset them.

There are two trip meters: Trip A and Trip B. Each trip meter works independently, so you can keep track of two different distances. To change the display to show Trip A, Trip B, or the odometer, press the Trip button repeatedly.

To reset a trip meter, display it, then press and hold the Trip button until the numbers reset to 0.0.

Trip Mileage

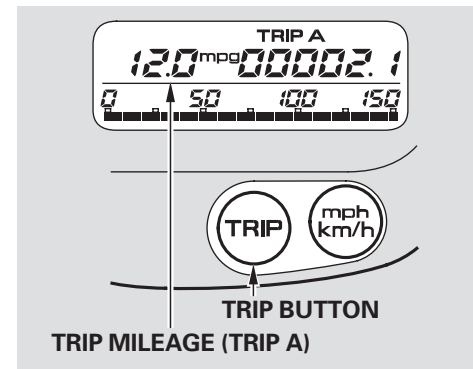

When a trip meter is displayed, the average fuel mileage you have been getting during that trip is shown in the Fuel Mileage display. This number is updated once per minute.

When you reset a trip meter, the average fuel mileage for that trip meter also resets.

This display can be turned off at any time. See page [52](#) .

Segment Distance and Fuel Mileage

Press the FCD select button to display the distance and average fuel mileage for a segment of a trip. The Segment Display indicator will come on to remind you that this is the segment distance and fuel mileage display.

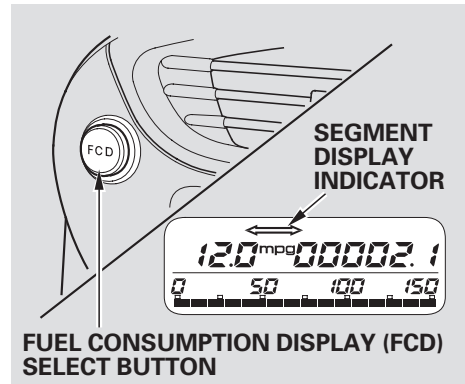

To reset the display, press and hold the FCD Select button until the display resets to zero and dashes. The system then begins displaying the distance and average fuel mileage from that point. The display is updated once per minute.

To switch between the segment display and the Trip Meter/Odometer display, press and release the FCD Select button.

Lifetime Fuel Mileage

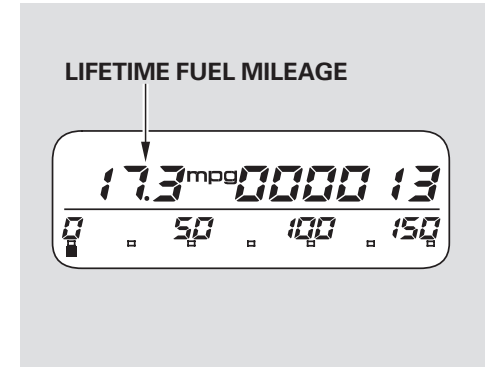

When the odometer is displayed, the Fuel Mileage display shows the lifetime fuel mileage. This is the average fuel mileage your vehicle has gotten since the last time the display was reset.

CONTINUED

Gauges

To reset this display, turn the ignition switch to ON (II), the transmission is in neutral or Park (CVT), and the parking brake is set. Use the Trip button to display the odometer. Then press and hold the Trip button until the Lifetime Fuel Mileage Display begins to blink (approximately five seconds). Release the Trip button, then press it again while the display is blinking and hold it until the display clears to dashes.

Turning Off the Mileage Displays

You can temporarily turn off the Current Fuel Mileage and Fuel Mileage displays.

To turn them off:

1. Turn the ignition switch to ON (II), the transmission is in neutral or Park (CVT), and the parking brake is set.
2. Use the Trip button to select Trip A, Trip B, or the odometer.
3. Press and hold the FCD Select button for approximately three seconds. The Current Fuel Mileage display will turn off.
4. Press and hold the FCD Select button again. The Fuel Mileage display for the meter you are displaying (Trip A, Trip B, or odometer) will turn off.

5. Use the Trip button to select another mileage display.

6. To turn off the other trip meters, select the meter with the Trip button, and hold the FCD select button.

Although the displays are turned off, the average fuel mileages continue to be calculated. The displays will turn back on when you press and hold the FCD Select button again.

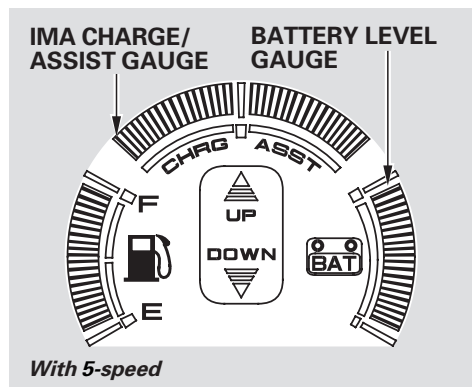

Battery Level Gauge

This gauge shows you the state of charge of the battery for the Integrated Motor Assist (IMA). This battery is recharged by the engine, and discharged by the IMA when it is assisting the engine with powering the vehicle.

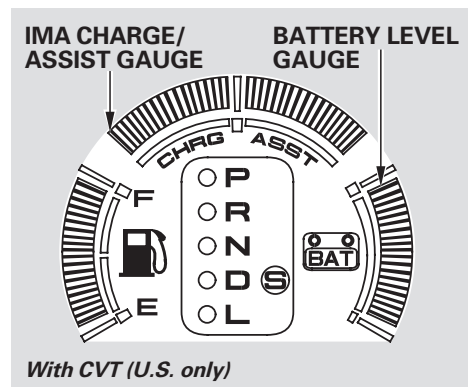

The gauge reading may drop near the bottom under driving conditions that require assist for a long time, such as prolonged acceleration or climbing a long hill. The engine will recharge the battery as you continue driving.

If the battery is mostly discharged, the Auto Idle Stop function is disabled (see pages [111](#) and [118](#)).

Charge/Assist Gauge

This gauge shows the status of the Integrated Motor Assist (IMA). If the indicator is on the left side of the gauge, the IMA battery is being charged. If the indicator is on the right side of the gauge, the IMA is assisting the engine.

Controls Near the Steering Wheel

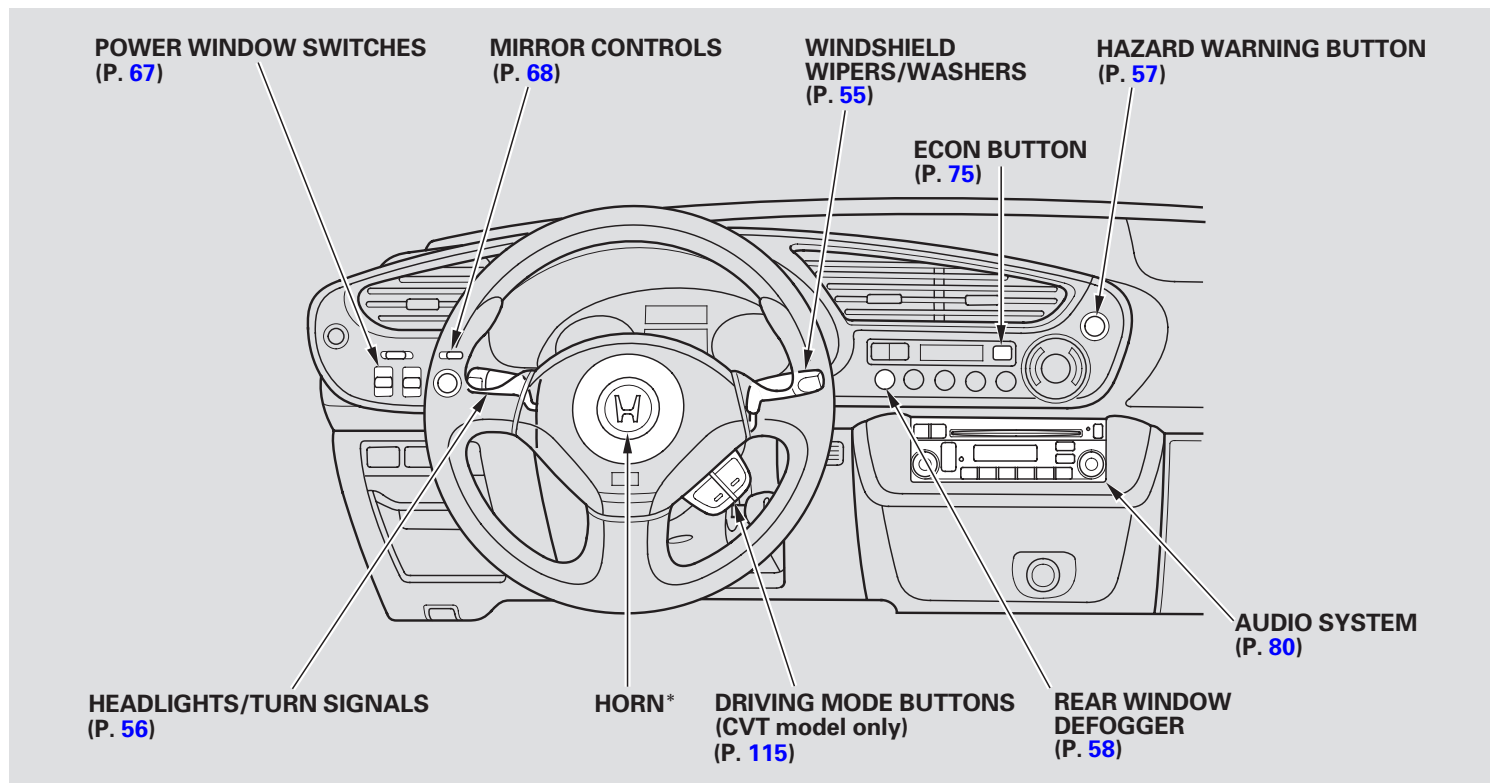

* : To use the horn, press the pad around the “H” logo.

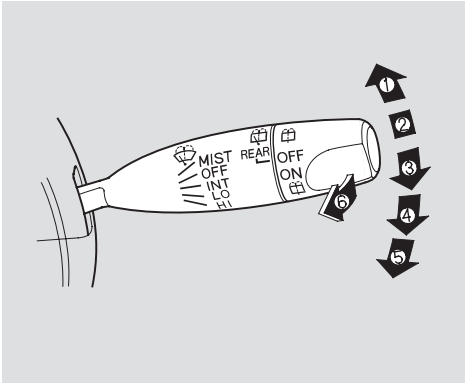

1. MIST
2. OFF
3. INT – Intermittent
4. LO – Low speed
5. HI – High speed
6. Windshield Washers

Push the right lever up or down to select a position.

MIST – The wipers run at high speed until you release the lever.

OFF – The wipers are not activated.

INT – The wipers operate every few seconds. In low speed and high speed, the wipers run continuously.

LO – The wipers run at low speed.

HI – The wipers run at high speed.

Windshield Washer – Pull the wiper control lever toward you and hold it. The washers spray until you release the lever. The wipers run at low speed, then complete one more sweep after you release the lever.

Rear Window Wiper and Washer

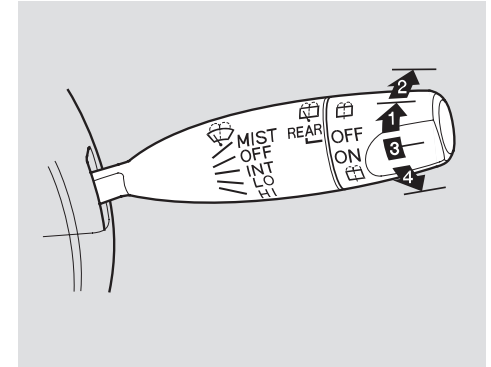

1. Rotate the switch clockwise to turn the rear window wiper ON.
2. Hold past ON to turn the window wiper on and the window washer to spray.
3. OFF
4. Rotate the switch counterclockwise to spray the window washer without activating the wiper.

Turn Signal and Headlights

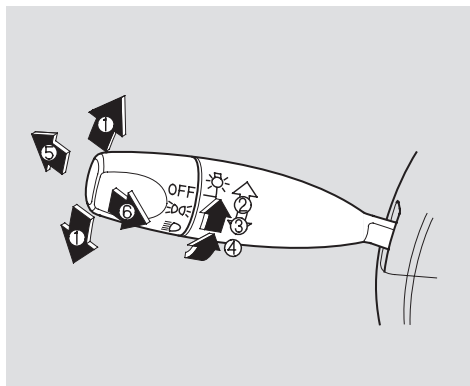

1. Turn Signal
2. OFF
3. Parking and interior lights
4. Headlights on
5. High Beams
6. Flash high beams

Turn Signal — Push down on the left lever to signal a left turn and up to signal a right turn. To signal a lane change, push lightly on the lever and hold it. The lever will return to center when you release it or complete a turn.

Headlights On — Turning the switch to the  position turns on the parking lights, taillights, instrument panel lights, side-marker lights, and rear license plate lights. Turning the switch to the  position turns on the headlights. If you leave the lights on with the key removed from the ignition switch, you will hear a reminder tone when you open the driver's door.

High Beams — Push the lever forward until you hear a click to turn on the high beams. The blue high beam indicator will come on (see page 46). Pull the lever back to return to the low beams.

To flash the high beams, pull the lever back lightly, then release it. The high beams will stay on as long as you hold the lever back.

Daytime Running Lights (Canadian Models)

With the headlight switch off, the high beam headlights come on with reduced brightness when you turn the ignition switch to ON (II) and release the parking brake. They remain on until you turn the ignition switch off, even if you set the parking brake.

The headlights revert to normal operation when you turn them on with the switch.

Instrument Panel Brightness, Hazard Warning Button

Instrument Panel Brightness

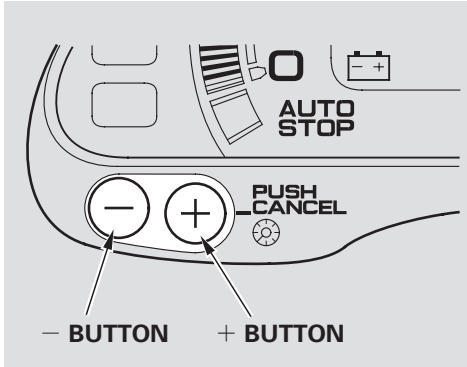

The buttons in the lower left corner of the instrument panel adjust the brightness of the display in six steps. Push the + or - button five times to see the full range.

The display dims when the parking lights or headlights are turned on. Adjust the brightness to the desired level with the headlight switch off, and also with the headlight switch on. Both settings will remain at those levels until you change them.

With the headlight switch on, you can switch the display to full daytime brightness by pushing and holding the + button. Push the - button to return the display to the original brightness.

Hazard Warning Button

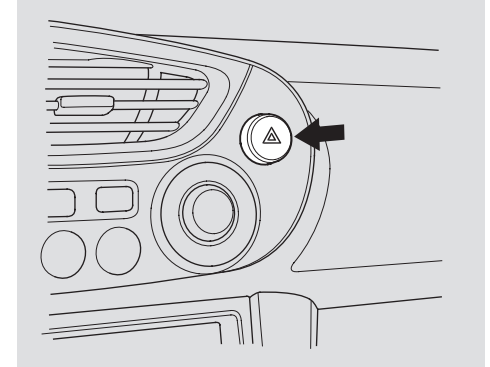

Push the button to the right of the center vents to turn on the hazard warning lights (four-way flashers). This causes all four outside turn signals and both indicators in the instrument panel to flash. Use the hazard warning lights if you need to park in a dangerous area near heavy traffic, or if your vehicle is disabled.

Rear Window Defogger

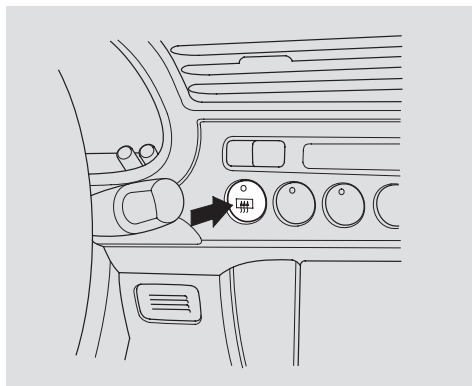

Manual Operation

The rear window defogger will clear fog, frost, and thin ice from the window. Push the defogger button to turn it on and off. The indicator in the button comes on to show the defogger is on. If you do not turn it off, the defogger will shut itself off after about 25 minutes. It also shuts off when you turn off the ignition switch. You have to turn it on again when you restart the vehicle.

Automatic Operation

The rear window defogger turns on automatically when you turn the ignition switch to ON (II) if the outside temperature is below 32°F (0°C), or if the engine is at ambient temperature. The indicator in the button does not light.

It will also turn off automatically after 25 minutes.

Make sure the rear window is clear and you have good visibility before starting to drive.

The defogger wires on the inside of the rear window can be accidentally damaged. When cleaning the glass, always wipe side to side.

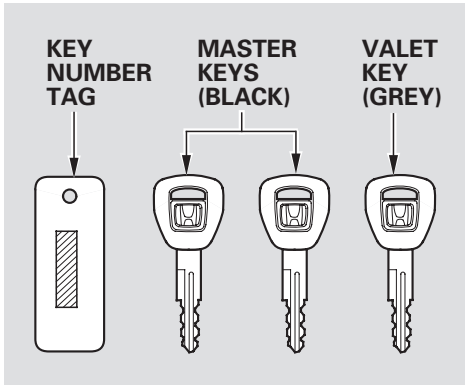

The master key fits all the locks on your vehicle.

The valet key works only in the ignition and the door locks. You can keep the glove box and the hatch locked when you leave your vehicle and the valet key at a parking facility.

You should have received a key number tag with your keys. You will need this key number if you ever have to get a lost key replaced. Use only Honda-approved key blanks.

These keys contain electronic circuits that are activated by the immobilizer system. They will not work to start the engine if the circuits are damaged.

- Protect the keys from direct sunlight, high temperature, and high humidity.

- Do not drop the keys or set heavy objects on them.
- Keep the keys away from liquids. If they get wet, dry them immediately with a soft cloth.

The keys do not contain batteries. Do not try to take them apart.

Immobilizer System

The immobilizer system protects your vehicle from theft. If an improperly-coded key (or other device) is used, the engine's fuel system is disabled.

When you turn the ignition switch to ON (II), the immobilizer system indicator should come on for a few seconds, then go out. If the indicator starts to blink, it means the system does not recognize the coding of the key. Turn the ignition switch to LOCK (0), remove the key, reinsert it, and turn the switch to ON (II) again.

The system may not recognize your key's coding if another immobilizer key or other metal object (i.e. key fob) is near the ignition switch when you insert the key.

If the system repeatedly does not recognize the coding of your key, contact your dealer.

Do not attempt to alter this system or add other devices to it. Electrical problems could result that may make your vehicle undriveable.

If you have lost your key and cannot start the engine, contact your dealer.

As required by the FCC:

This device complies with Part 15 of the FCC rules. Operation is subject to the following two conditions: (1) This device may not cause harmful interference, and (2) this device must accept any interference received, including interference that may cause undesired operation.

Changes or modifications not expressly approved by the party responsible for compliance could void the user's authority to operate the equipment.

This device complies with Industry Canada Standard RSS-210.

Operation is subject to the following two conditions: (1) this device may not cause interference, and (2) this device must accept any interference that may cause undesired operation of the device.

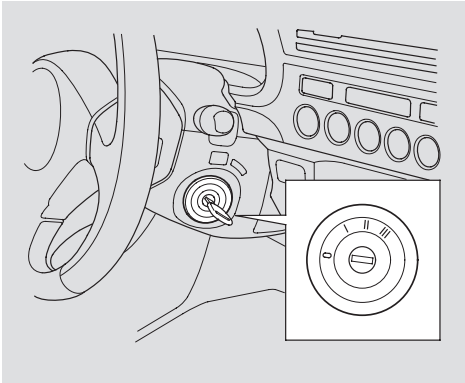

The ignition switch has four positions: LOCK (0), ACCESSORY (I), ON (II), and START (III).

LOCK (0) — You can insert or remove the key only in this position. To turn the key, push it in slightly. If your vehicle has an automatic transmission, the shift lever must also be in park.

If the front wheels are turned, the anti-theft lock may make it difficult to turn the key. Firmly turn the steering wheel to the left or right as you turn the key.

ACCESSORY (I) — You can operate the audio system and the accessory power socket in this position.

ON (II) — This is the normal key position when driving. Several of the indicators on the instrument panel come on as a test when you turn the ignition switch from ACCESSORY (I) to ON (II).

START (III) — Use this position only to start the engine. The switch returns to ON (II) when you let go of the key.

⚠ WARNING

Removing the key from the ignition switch while driving locks the steering. This can cause you to lose control of the vehicle.

Remove the key from the ignition switch only when parked.

You will hear a reminder beeper if you leave the key in the ignition switch in the LOCK (0) or ACCESSORY (I) position and open the driver's door. Remove the key to turn off the beeper.

If your vehicle has an automatic transmission, the shift lever must be in Park before you can remove the key from the ignition switch.

Door Locks

Power Door Locks

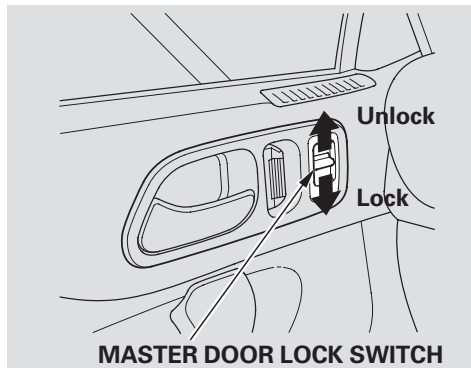

The master door lock switch allows control of all door and hatch locks from the driver's door. Push the switch down to lock both doors and the hatch, and up to unlock them.

Door Locks

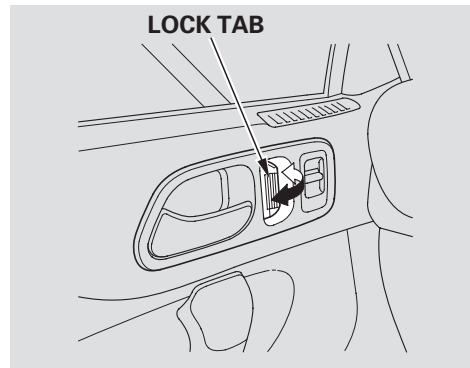

Each door has a lock tab next to the inside door handle. Push the tab in to lock the door, and pull it out to unlock.

To lock the passenger's door when getting out of the vehicle, push the lock tab in and close the door. To lock the driver's door, pull the door handle and push the lock tab in. Release the handle, then close the door.

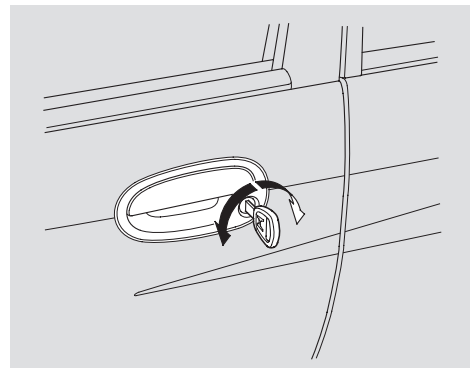

The doors can also be locked and unlocked from the outside with the key.

Hatch

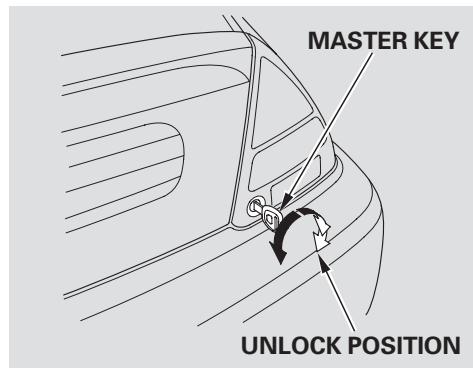

Use the master key to lock and unlock the hatch. The valet key does not work in this lock. To lock the hatch, turn the key counterclockwise. To unlock the hatch, turn it clockwise.

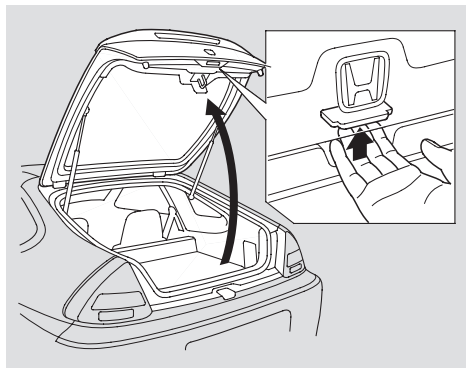

To open the hatch, push the lever behind the hatch's back edge. To close the hatch, push down on the back edge.

Keep the hatch closed at all times while driving to avoid damaging it and to prevent exhaust gas from getting into the interior. See **Carbon Monoxide Hazard** on page 38.

If an unlocked hatch does not open, turn the key clockwise past the unlock position. Open the hatch as you hold the key in that position.

If you need to use this procedure to open the hatch, your vehicle may be developing a problem. Have the vehicle checked by your dealer.

Remote Transmitter

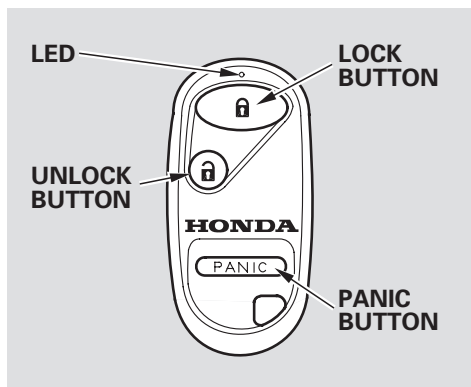

LOCK — Press this button once to lock both doors and the rear hatch. Some exterior lights will flash. When you push LOCK twice within 5 seconds, you will hear a horn to verify that the doors and the rear hatch are locked. You cannot lock them if either door is not fully closed or the key is in the ignition switch.

UNLOCK — Press this button once to unlock the driver's door. Some exterior lights will flash twice. Push it twice to unlock the passenger's door, and rear hatch. If you do not open either door or the rear hatch within 30 seconds, they will automatically relock.

The interior light (if the interior light switch is in the center position) will come on when you press the UNLOCK button. If you do not open either door or the rear hatch, the light will go out in about 30 seconds, and the doors and the rear hatch will automatically relock. If you relock the doors and the rear hatch with the remote transmitter before 30 seconds have elapsed, the light will go off immediately.

PANIC — Press this button for about 1 second to attract attention; the horn will sound and the exterior lights will flash for about 30 seconds. To cancel panic mode, press any other button on the remote transmitter, or turn the ignition switch to ON (II).

Remote Transmitter Care

- Avoid dropping or throwing the transmitter.
- Protect the transmitter from extreme temperature.
- Do not immerse the transmitter in any liquid.
- If you lose a transmitter, the replacement needs to be reprogrammed by your dealer.

Replacing the Transmitter Battery

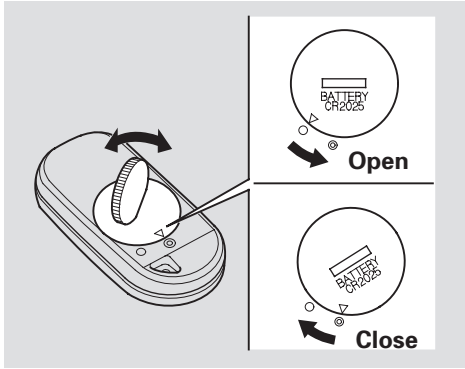

If it takes several pushes on the button to lock or unlock the doors and the rear hatch, replace the battery as soon as possible.
Battery type: CR2025

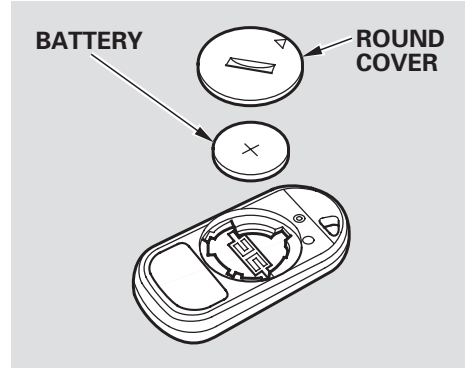

To replace the battery, remove the round cover on the back of the transmitter by turning it counterclockwise with a coin. Insert a new battery with the + side facing up. Align the ∇ mark on the cover with the © mark on the transmitter. Set the cover in place, and turn it clockwise.

As required by the FCC:

This device complies with Part 15 of the FCC rules. Operation is subject to the following two conditions: (1) This device may not cause harmful interference, and (2) this device must accept any interference received, including interference that may cause undesired operation.

Changes or modifications not expressly approved by the party responsible for compliance could void the user's authority to operate the equipment.

This device complies with Industry Canada Standard RSS-210.

Operation is subject to the following two conditions: (1) this device may not cause interference, and (2) this device must accept any interference that may cause undesired operation of the device.

Seats

See pages 12 – 14 for important safety information and warnings about how to properly position the seats and seat-backs.

Make all seat adjustments before you start driving.

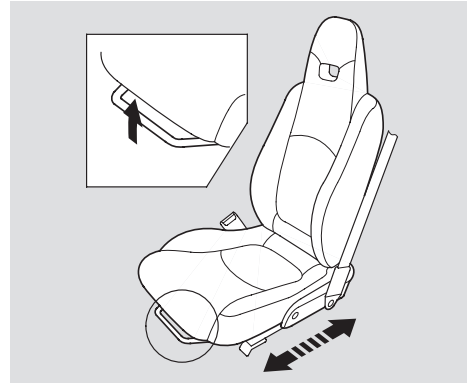

To adjust the seat forward and backward, pull up on the lever under the seat cushion's front edge. Move the seat to the desired position and release the lever. Try to move the seat to make sure it is locked in position.

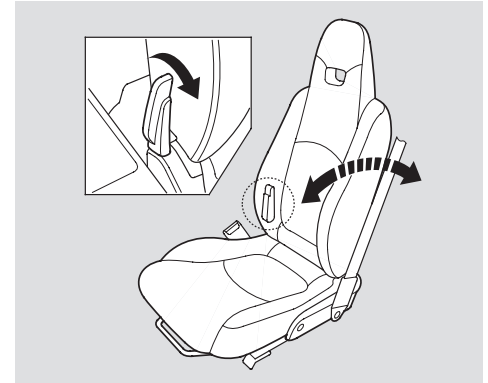

To change the seat-back angle, push forward the lever next to the seat bolster, on the side of the seat-back.

Your vehicle's windows are electrically-powered. Turn the ignition switch to ON (II) to raise or lower either window.

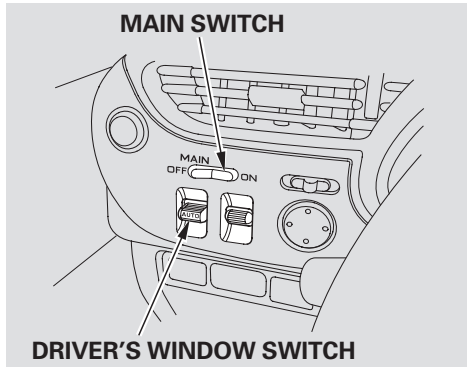

There is a master power window control panel on the dashboard. To open the passenger's window, push down on the switch and hold it down until the window reaches the desired position. To close the window, push up on the window switch. Release the switch when the window gets to the position you want.

⚠ WARNING

Closing a power window on someone's hands or fingers can cause serious injury.

Make sure your passenger is away from the window before closing it.

AUTO – To open the driver's window fully, push the window switch firmly down and release it. The window automatically goes all the way down. To stop the window from going all the way down, push up on the window switch briefly. To open the driver's window only partially, push the window switch down lightly and hold it. The window will stop as soon as you release the switch.

The AUTO function only works to lower the driver's window. To raise the window, you must push the window switch up and hold it until the window reaches the desired position.

The MAIN switch controls power to the passenger's window. With this switch off, the passenger's window cannot be raised or lowered. The MAIN switch does not affect the driver's window. Keep the MAIN switch off when you have a child in the vehicle so the child does not get injured by operating the window unintentionally.

Mirrors

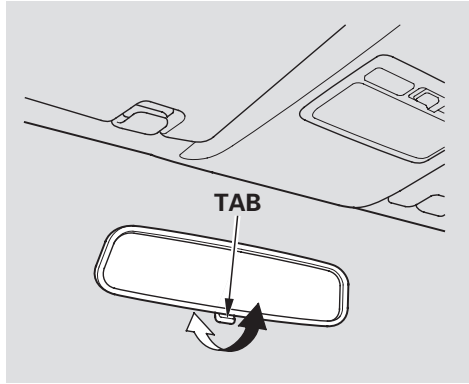

Keep the inside and outside mirrors clean and adjusted for best visibility. Be sure to adjust the mirrors before you start driving.

The inside mirror has day and night positions. The night position reduces glare from headlights behind you. Flip the tab on the bottom edge of the mirror to select the day or night position.

Adjusting the Power Mirrors

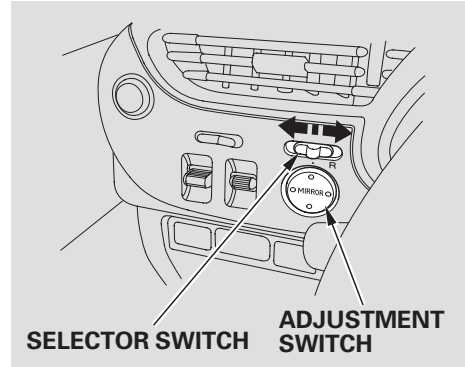

1. Turn the ignition switch to ON (II).
2. Move the selector switch to L (driver's side) or R (passenger's side).

3. Push the appropriate edge of the adjustment switch to move the mirror right, left, up, or down.
4. When you finish, move the selector switch to the center (off) position. This turns the adjustment switch off to keep your settings.

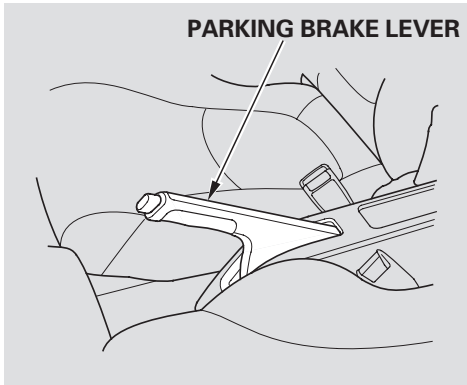

NOTICE

Driving the vehicle with the parking brake applied can damage the rear brakes and axles.

To apply the parking brake, pull the lever up fully. To release it, pull up slightly, push the button, and lower the lever. The parking brake indicator on the instrument panel should go out when the parking brake is fully released (see page [45](#)).

Interior Convenience Items

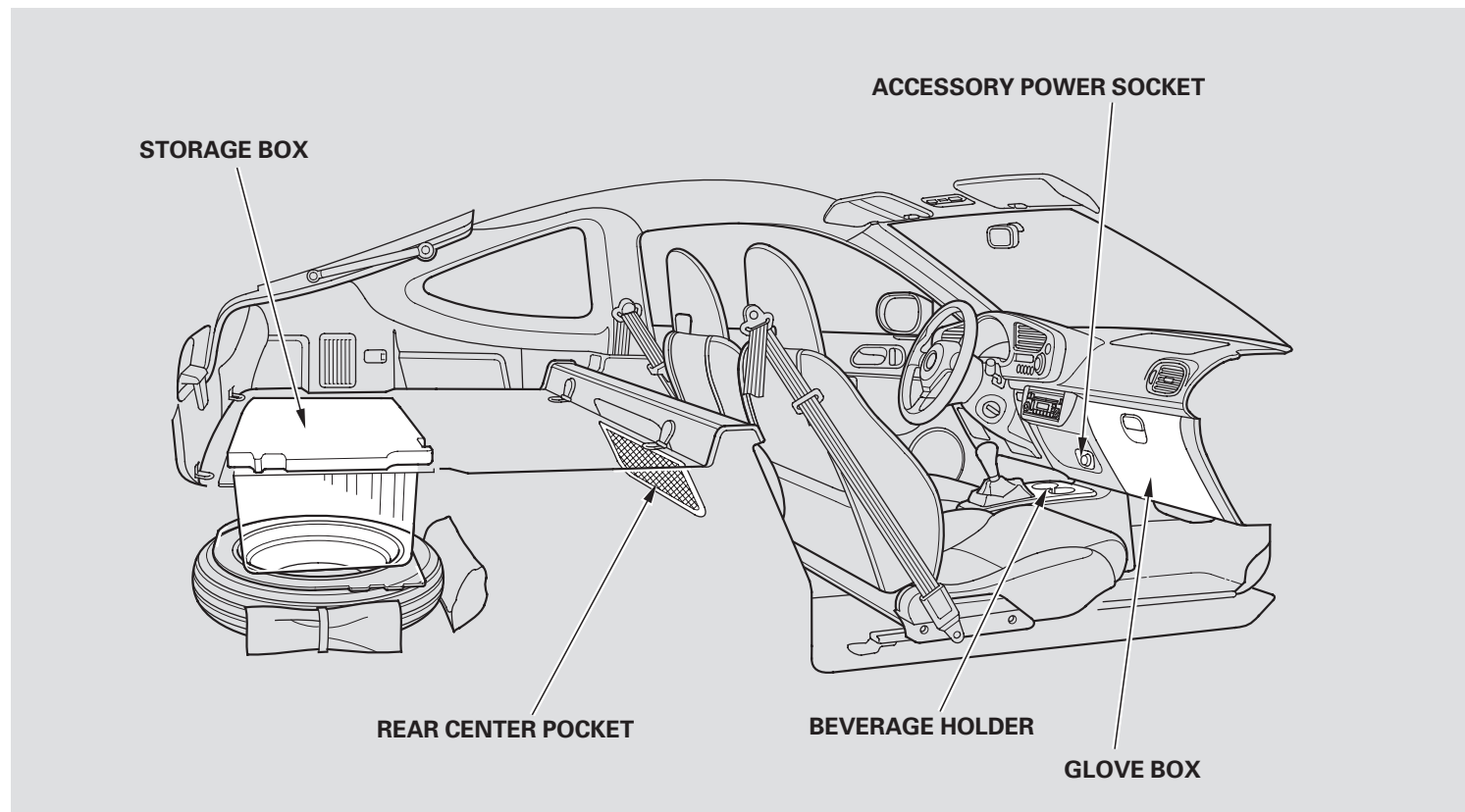

Storage Box

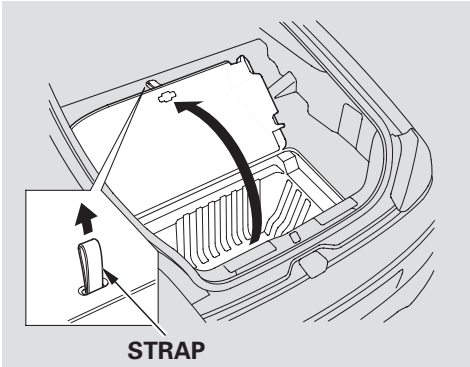

To open the storage box, pull the strap.

Beverage Holder

Be careful when you are using the beverage holders. A spilled liquid that is very hot can scald you or your passenger. Spilled liquids can also damage the upholstery, carpeting, and electrical components in the interior.

Glove Box

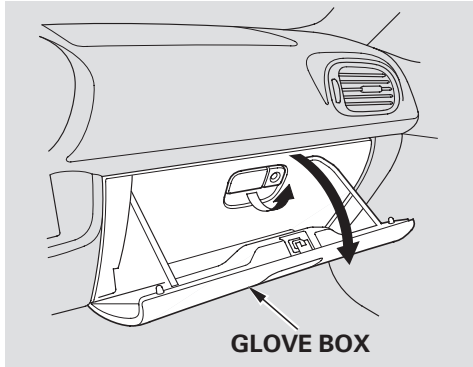

Open the glove box by pulling the bottom of the handle. Close it with a firm push. Lock or unlock the glove box with the master key.

⚠️ WARNING

An open glove box can cause serious injury to your passenger in a crash, even if the passenger is wearing the seat belt.

Always keep the glove box closed while driving.

Accessory Power Socket

To use the accessory power socket, pull up the cover. The ignition switch must be in ACCESSORY (I) or ON (II).

This socket is intended to supply power for 12 volt DC accessories that are rated 120 watts or less (10 amps).

They will not power an automotive type cigarette lighter element.

Interior Lights

Ceiling Light

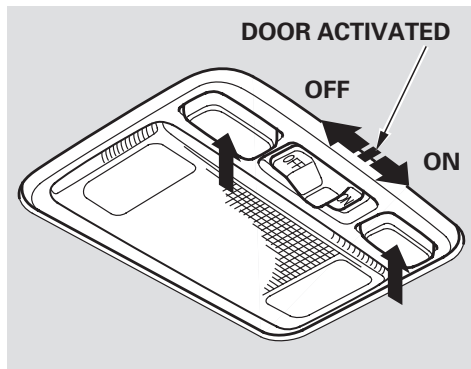

The ceiling light has a three-position switch; ON, Door Activated, and OFF. In the Door Activated (center) position, the light comes on when you:

- Open either door or the rear hatch.
- Unlock the doors and the rear hatch with the remote transmitter.

The ceiling light also contains two spotlights. Push the button next to the light to turn it on and off. You can use the spotlights at all times.

Cargo Area Light

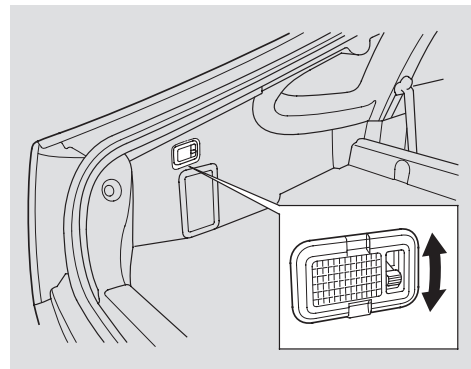

The cargo area light has a two-position switch. In the OFF (down) position, the light does not come on. In the ON (up) position, the light comes on when you open the hatch.

The heating and air conditioning* systems in your vehicle provide a comfortable driving environment in all weather conditions.

The standard audio system has many features. This section describes those features and how to use them.

Your vehicle has an anti-theft audio system that requires a code number to enable it.

*Air conditioning is standard on vehicles with automatic transmission (CVT) and standard on most manual transmissions.

Vents, Heating, and A/C	74
ECON Button	75
To Cool or Heat Automatically ..	78
Playing the Radio	80
Radio Reception	83
Playing a CD	85
CD Changer	87
Protecting Your CDs	87
CD Player Error Messages	88
CD Changer Error Messages	89
Radio Theft Protection	90
Setting the Clock	91

Vents, Heating, and A/C

On vehicles without climate control

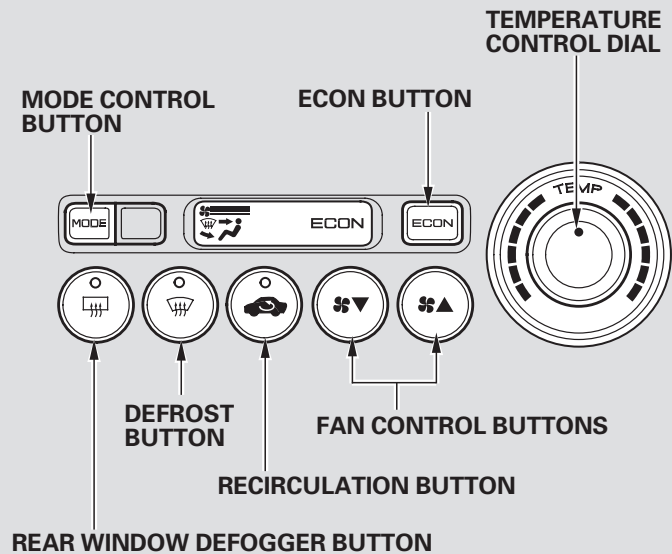

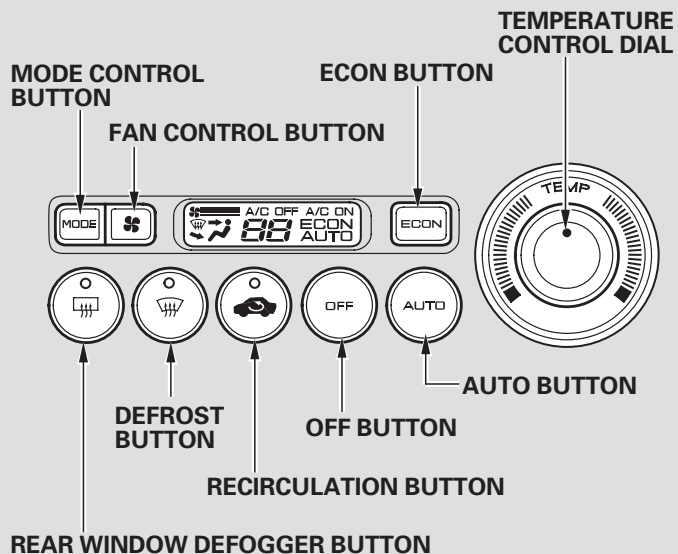

On vehicles with climate control



On vehicles with automatic transmission (CVT), see page 78 for Automatic Climate Control and Manual Operations information.

Fan Control

You can manually select the fan speed by pressing the fan control button ( / ▲ or ▼). The fan speed is shown by bars in the display.

Temperature Control Dial

Turning this dial clockwise increases the temperature of the airflow.

ECON Button

If the A/C is on when this button is pressed, the auto idle stop works only if the outside temperature is above 41°F (5°C).

If the cooling provided in ECON mode is not adequate, press the Auto button (see page 78).

Recirculation Button

When the recirculation indicator is on, air from the vehicle's interior is sent throughout the system again. When the indicator is off, air is brought in from the outside of the vehicle (fresh air mode).

The outside air intakes for the heating and cooling system are at the base of the windshield. Keep this area clear of leaves and other debris.

The system should be left in Fresh Air mode under almost all conditions. Keeping the system in Recirculation mode, can cause the windows to fog up.

Switch to recirculation mode when driving through dusty or smoky conditions, then return to fresh air mode.

Rear Window Defogger Button

This button turns the rear window defogger off and on (see page 58).

Mode Control Button

Press the mode control button to select the vents the air flows from. Some air will flow from the dashboard corner vents in all modes.

 Air flows from the center and corner vents in the dashboard.

CONTINUED

Vents, Heating, and A/C

 Airflow is divided between the vents in the dashboard and the floor vents.

 Air flows from the floor vents.

 Airflow is divided between the floor vents and the defroster vents at the base of the windshield.

 Air flows from the defroster vents at the base of the windshield.

When you select  or  , the system automatically switches to Fresh Air mode and turns on the A/C (on climate control model only).

When  mode is selected, the auto idle stop function will not activate.

Ventilation

The flow-through ventilation system draws in outside air, circulates it through the interior, then exhausts it through vents near the rear window.

1. Set the temperature to the lower limit.
2. Select  and Fresh Air mode.
3. Set the fan to the desired speed.

On vehicles with automatic transmission (CVT), make sure the display shows A/C OFF.

Using the Heater

The heater uses engine coolant to warm the air. If the engine is cold, it will be several minutes before you feel warm air coming through the system.

1. Select  and Fresh Air mode.
2. Set the fan to the desired speed.
3. Adjust the warmth of the air with the temperature control dial.

Using the A/C in ECON Mode

On vehicles with automatic transmission (CVT)

Air conditioning places an extra load on the engine. Watch the engine coolant temperature gauge (see page 49). If it moves near the red zone, turn off the A/C until the gauge reads normally.

1. Turn on the ECON mode by pressing the ECON button. The display shows A/C ON. Press the ECON button again to turn the ECON mode off.
2. Make sure the temperature is set to maximum cool.
3. Select  .
4. If the outside air is humid, select Recirculation mode. If the outside air is dry, select Fresh Air mode.
5. Set the fan to the desired speed.
If the interior is very warm, you can cool it down more rapidly by partially opening the windows, turning on the AUTO, and setting the fan to maximum speed in Fresh Air mode.

To Dehumidify the Interior

On vehicles with climate control

Air conditioning, as it cools, removes moisture from the air. When used in combination with the heater, it makes the interior warm and dry.

1. Turn the fan on.
2. Turn on the air conditioning.
3. Select  and Fresh Air mode.
4. Adjust the temperature control dial to your preference.

This setting is suitable for all driving conditions whenever the outside temperature is above 32°F (0°C).

To Defog and Defrost

To remove fog from the inside of the windows:

1. Set the fan to the desired speed.
2. Select , the system automatically switches to Fresh Air mode. On vehicles with climate control, the system also turns on the A/C. The A/C

indicator will not come on, if it was off to start with.



3. Adjust the temperature control dial so the airflow feels warm.
4. Select  to help clear the rear window.

When  mode is selected, the auto idle stop function will not activate.

When you switch to another mode from , the A/C stays on. Press the ECON button to turn it off.

When you turn off  by pressing the button again, the system returns to its former settings.

To Remove Exterior Frost or Ice From the Windows

1. Select . The system automatically switches to Fresh Air mode. On vehicles with climate control, the system also turns on the A/C. The A/C indicator will not come on, if it was off to start with.
2. Select .
3. Set the fan and temperature controls to the maximum level.

To clear the windows faster, you can close the dashboard corner vents by rotating the wheel next to them. This will send more warm air to the windshield defroster vents. Once the windshield is clear, select the Fresh Air mode to avoid fogging the windows.

For your safety, make sure you have a clear view through all the windows before driving.

Vents, Heating, and A/C

To Cool or Heat Automatically

On vehicles with automatic transmission (CVT)

The Automatic Climate Control system can adjust the fan speed and airflow levels to maintain the interior temperature you select.

Using Automatic Climate Control

On vehicles with automatic transmission (CVT)

1. Press the Auto button.
2. Set the desired temperature by turning the Temperature Control dial. You will see AUTO in the system's display.

When the system is in fully automatic mode, the auto idle stop function will not be activated.

The system automatically selects the proper mix of conditioned and/or heated air to raise or lower the interior temperature to the temperature you selected.

If you set the temperature to its lower limit or its highest limit, the system runs at full cooling or heating only. It does not regulate the interior temperature.

In cold weather, the fan will not come on automatically until the heater starts to develop warm air.

Manual Operation

On vehicles with automatic transmission (CVT)

You can manually select various functions of the automatic climate control system when it is in AUTO. All other features remain automatically controlled.

Making any manual selection causes the word AUTO in the display to go out.

To Turn Everything Off

On vehicles with manual transmission

To shut off the system completely, turn off the fan and turn the temperature control dial all the way to the left.

On vehicles with automatic transmission (CVT)

If you press OFF, the Climate Control system shuts off completely.

- Keep the system completely off for short periods only.
- To keep stale air and mustiness from collecting, you should have the fan running at all times.

Sunlight and Temperature Sensors

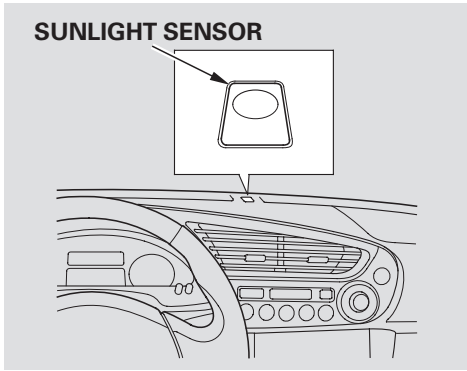

The climate control system has two sensors. A sunlight sensor is in the top of the dashboard, and a temperature sensor is next to the steering column. Do not cover the sensors or spill any liquid on them.

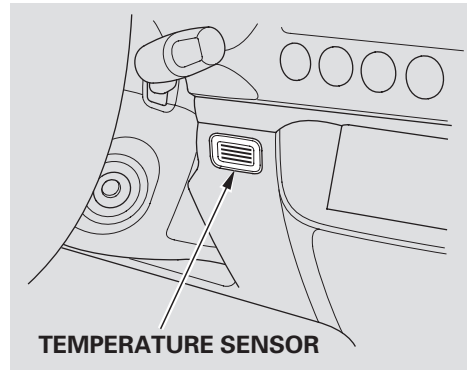

Playing the Radio

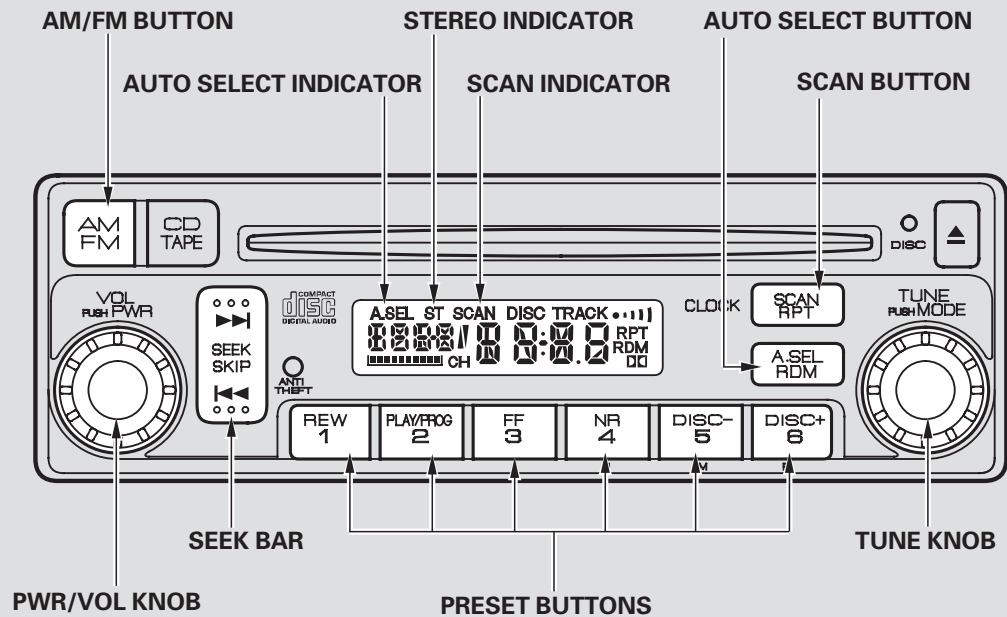

To Play the Radio

The ignition switch must be in the ACCESSORY (I) or ON (II) position. Turn the system on by pushing the PWR/VOL knob or the AM/FM button. Adjust the volume by turning the PWR/VOL knob.

The band and frequency that the radio was last tuned to is displayed. To change bands, press the AM/FM button. On the FM band, ST will be displayed if the station is broadcasting in stereo. Stereo reproduction on AM is not available.

To Select a Station

You can use these five methods to find radio stations on a selected band: **TUNE**, **SEEK**, **SCAN**, the preset buttons, and **AUTO SELECT**.

TUNE — Use the TUNE knob to tune the radio to a desired frequency. Turn the knob right to tune to a higher frequency, or left to tune to a

lower frequency.

SEEK — The SEEK function searches up and down from the current frequency to find a station with a strong signal. To activate it, press the ◀◀ or ▶▶ side of the bar, then release it.

SCAN — The SCAN function samples all stations with strong signals on the selected band. To activate it, press the SCAN button, then release it. You will see SCAN in the display. The system will scan for a station with a strong signal. When it finds one, it will stop and play that station for about 5 seconds.

If you do nothing, the system will scan for the next strong station and play it for 5 seconds. When it plays a station you want to listen to, press the SCAN button again.

Preset — Each preset button can store one frequency on AM, and two frequencies on FM.

1. Select the desired band, AM or FM. FM1 and FM2 let you store two frequencies with each preset button.
2. Use the TUNE, SEEK, or SCAN function to tune the radio to a desired station.
3. Pick a preset button, and hold it until you hear a beep.
4. Repeat steps 1 through 3 to store a total of six stations on AM and twelve stations on FM.

The preset frequencies will be lost if your vehicle's battery goes dead, is disconnected, or the radio fuse is removed.

CONTINUED

Playing the Radio

AUTO SELECT — If you are traveling far from home and can no longer receive your preset stations, you can use the auto select feature to find stations in the local area.

Press the A. SEL button. “A.SEL” flashes in the display, and the system goes into scan mode for several seconds. It stores the frequencies of six AM, and twelve FM stations in the preset buttons.

You will see a “0” displayed after pressing a preset button if Auto Select cannot find a strong station for every preset button.

If you do not like the stations Auto Select has stored, you can store other frequencies on the preset buttons as previously described.

To turn off auto select, press the A. SEL button. This restores the presets you originally set.

Adjusting the Sound

BAL — Adjust the Balance, or side-to-side strength of the sound.

FAD — Adjust the Fader, or the front-to-back strength of the sound.

TRE — Adjust the Treble in the sound.

BAS — Adjust the Bass in the sound.

Press the MODE (TUNE) knob repeatedly to display the Bass (BAS), Treble (TRE), Fader (FAD), and Balance (BAL) settings.

Turn the knob to adjust the setting. When the level reaches the center, you will see a “C” in the display. The system will return to the audio display in about 5 seconds.

Audio System Lighting

You can use the instrument panel brightness control buttons to adjust the illumination of the audio system (see page 57). The audio system illuminates when the parking lights are on, even if the radio is off.

Radio Frequencies

The radio can receive the complete AM and FM bands.

Those bands cover these frequencies:

AM band: 530 to 1,710 kilohertz

FM band: 87.7 to 107.9 megahertz

Radio stations on the AM band are assigned frequencies at least ten kilohertz apart (530, 540, 550).

Stations on the FM band are assigned frequencies at least 0.2 megahertz apart (87.9, 88.1, 88.3).

Stations must use these exact frequencies. It is fairly common for stations to round-off the frequency in their advertising, so your radio could display a frequency of 100.9 even though the announcer may identify the station as “FM101.”

Radio Reception

How well the radio receives stations is dependent on many factors, such as the distance from the station’s transmitter, nearby large objects, and atmospheric conditions.

A radio station’s signal gets weaker as you get farther away from its transmitter. If you are listening to an AM station, you will notice the sound volume becoming weaker and the station drifting in and out. If you are listening to an FM station, you will see the stereo indicator flickering off and on as the signal weakens. Eventually, the stereo indicator will go off and the sound will fade completely as you get out of range of the station’s signal.

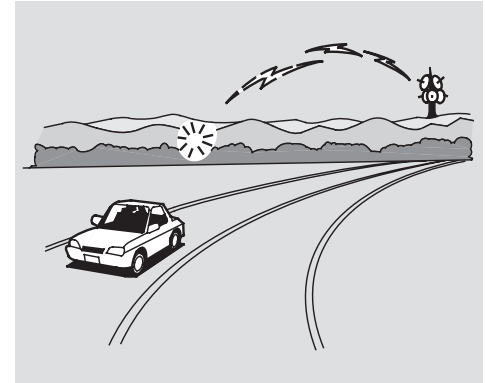

Driving very near the transmitter of a station that is broadcasting on a frequency close to the frequency of the station you are listening to can also affect your radio’s reception. You may temporarily hear both stations, or hear only the station you are close to.

CONTINUED

Radio Reception

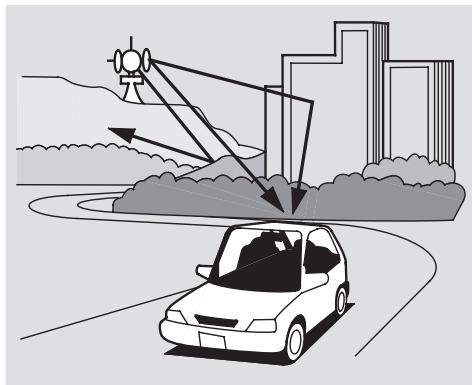

Radio signals, especially on the FM band, are deflected by large objects such as buildings and hills. Your radio then receives both the direct signal from the station's transmitter, and the deflected signal. This causes the sound to distort or flutter. This is a main cause of poor radio reception in city driving.



Radio reception can be affected by atmospheric conditions such as thunderstorms, high humidity, and even sunspots. You may be able to receive a distant radio station one day and not receive it the next day because of a change in conditions.

Electrical interference from passing vehicles and stationary sources can cause temporary reception problems.

*As required by the FCC:
Changes or modifications not expressly
approved by the party responsible for
compliance could void the user's
authority to operate the equipment.*

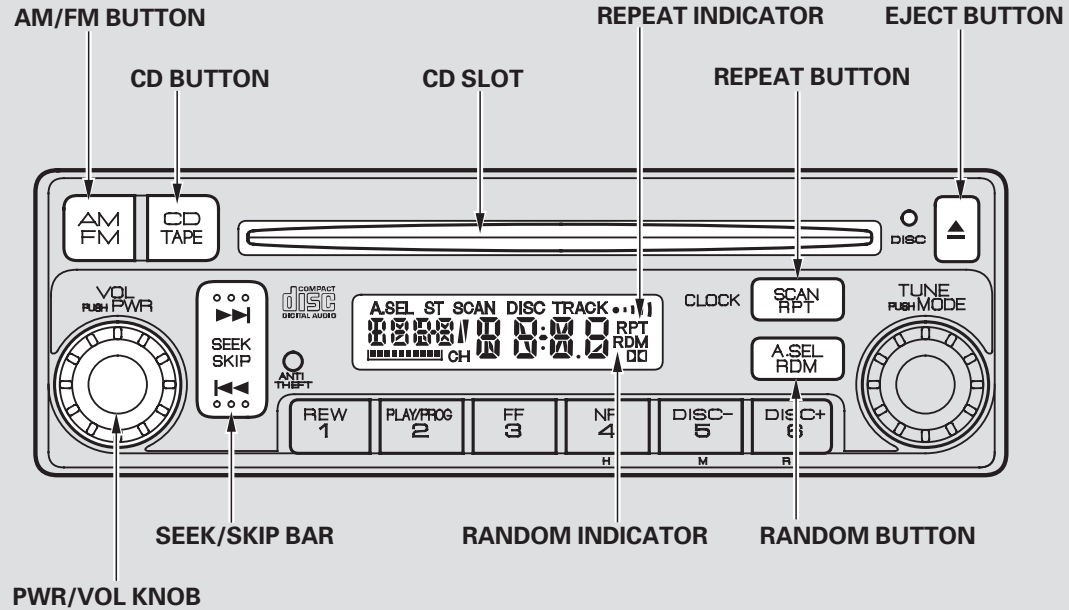

Playing a CD

To Play a CD

With the ignition switch in the ACCESSORY (I) or ON (II) position, insert a CD into the CD slot. The drive will pull the CD in the rest of the way and begin to play it. The number of the track playing is shown in the display. The system will continuously play a CD until you change modes.

NOTICE

Do not use discs with adhesive labels. The label can curl up and cause the disc to jam in the unit.

SKIP — Each time you press and release the ►► side of the skip bar, the player skips forward to the beginning of the next track. Press and release the ◄◄ side of the bar to skip backward to the beginning of the current track. Press it again to skip to the beginning of the previous track.

To move rapidly within a track, press and hold the ►► or ◄◄ side. You will see CUE or REW in the display.

REPEAT — To continuously replay a track, press and release the RPT button. You will see RPT in the display. Press it again to turn it off.

RANDOM — This feature plays the tracks in random order. To activate Random Play, press and release the RDM button. You will see RDM in the display. Press it again to return to normal play.

To Stop Playing a CD

Press the eject button (▲) to remove the CD. If you eject the CD, but do not remove it from the slot, the system will automatically reload the CD after 15 seconds and put it in pause mode. To begin playing, press the CD button.

Press the AM/FM button to switch to the radio while a CD is playing. Press the CD button to play the CD.

If you turn the system off while a CD is playing, either with the PWR/VOL knob or by turning off the ignition switch, the CD will stay in the drive. When you turn the system back on, the CD will begin playing where it left off.

Operating the Optional CD Changer

An optional six disc CD changer is available for your vehicle. This CD changer uses the same controls used for the in-dash CD player.

Load the desired CDs in the magazine, and load the magazine in the changer according to the instructions that came with the unit.

To select the CD changer, press the CD button. The CD and track numbers will be displayed. To select a different CD, use the preset 5 (DISC -) or preset 6 (DISC +) button. If you select an empty slot in the magazine, the changer will, after finding that slot empty, try to load the CD in the next slot.

Protecting Your CDs

General Information

- When using CD-R discs, use only high quality CDs labeled for audio use.
- When recording a CD-R, the recording must be closed for it to be used by the system.
- CD-RW discs will not work in this unit.
- Play only standard round CDs. Odd-shaped CDs may jam in the drive or cause other problems.
- Handle your CDs properly to prevent damage and skipping.

Protecting CDs

When a CD is not being played, store it in its case to protect it from dust and other contamination. To prevent warpage, keep CDs out of direct sunlight and extreme heat.

To clean a CD, use a clean soft cloth. Wipe across the CD from the center to the outside edge.

A new CD may be rough on the inner and outer edges. The small plastic pieces causing this roughness can flake off and fall on the recording surface of the CD, causing skipping or other problems. Remove these pieces by rubbing the inner and outer edges with the side of a pencil or pen.

Never try to insert foreign objects in the CD player or the magazine.

CONTINUED

Protecting Your CDs, CD Player Error Messages

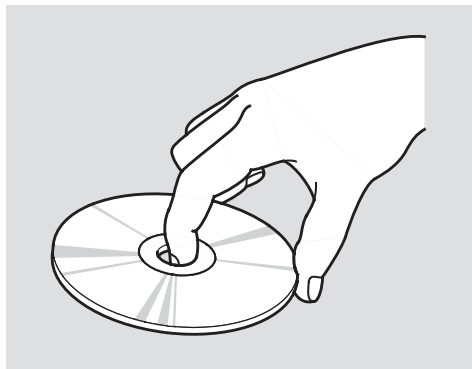

Handle a CD by its edges; never touch either surface. Do not place stabilizer rings or labels on the CD. These, along with contamination from fingerprints, liquids, and felt-tip pens, can cause the CD to not play properly, or possibly jam in the drive.

CD Player Error Messages

If you see an error message in the display while playing a CD, find the cause in the following chart. If you cannot clear the error message, take the vehicle to your dealer.

Error Message	Cause	Solution
<i>CD DISC</i>	FOCUS Error	Press the EJECT button and pull out the CD. Check if it is inserted correctly in the CD player. Make sure the CD is not scratched or damaged.
<i>CD ERR</i>	Mechanical Error	Press the EJECT button and pull out the CD. Check the CD for damage or deformation. If the CD cannot be pulled out, or the error message does not disappear after the CD is ejected, see your dealer.
<i>CD Hot</i>	High temperature	Will disappear when the temperature returns to normal.

CD Changer Error Messages

If you see an error message in the display while operating the CD changer, find the cause in the chart to the right. If you cannot clear the error message, take the vehicle to your dealer.

Error Message	Cause	Solution
<i>CD DISC</i>	FOCUS Error	Press the magazine eject button and pull out the magazine, check for error message. Insert the magazine again. If the message does not disappear or the magazine cannot be pulled out, see your dealer.
	No CD in the CD magazine	Insert CD.
<i>CD ERR</i>	Mechanical Error	Press the magazine eject button and pull it out. Check for error message, and insert the magazine again. If the error message does not disappear or the magazine cannot be pulled out, see your dealer.
<i>CD Hot</i>	High temperature	Will disappear when the temperature returns to normal.
<i>CD EJECT</i>	No CD magazine in the CD changer	Insert CD magazine.

Radio Theft Protection

Your vehicle's audio system will disable itself if it is disconnected from electrical power for any reason. To make it work again, you must enter a specific five-digit code in the preset buttons. Because there are hundreds of number combinations possible from five-digits, making the system work without knowing the exact code is nearly impossible.

You should have received a card that lists your audio system's code and serial numbers. It is best to store this card in a safe place at home. In addition, you should write the audio system's serial number in this Owner's Manual.

If you lose the card, you must obtain the code number from a dealer. To do this, you will need the system's serial number.

If your vehicle's battery is disconnected or goes dead, or the radio fuse is removed, the audio system will disable itself. If this happens, you will see "CODE" in the frequency display the next time you turn on the system. Use the preset buttons to enter the five-digit code. The code is located on the radio code card included in your Owner's Manual kit. When it is entered correctly, the radio will start playing.

If you make a mistake entering the code, do not start over; complete the five-digit sequence, then enter the correct code. You have ten tries to enter the correct code. If you are unsuccessful in ten attempts, you must then leave the system on for 1 hour before trying again.

You will have to store your favorite stations in the preset buttons after the system begins working. Your original settings were lost when the power was disconnected.

Setting the Clock

If your vehicle's battery is disconnected or goes dead, you will need to set the clock.

Press and hold the **CLOCK** button, and change the hours by pressing the **H** (Preset 4) button until the numbers advance to the desired time. To change the minutes, press and hold the **CLOCK** button, and press the **M** (Preset 5) button until the numbers advance to the desired time.

You can quickly set the time to the nearest hour. If the displayed time is before the half hour, press and hold the **CLOCK** button, and press the **R** (Preset 6) button to set the clock back to the previous hour. If the displayed time is after the half hour, the clock sets forward to the beginning of the next hour.

For example: 1:06 will reset to 1:00
1:52 will reset to 2:00

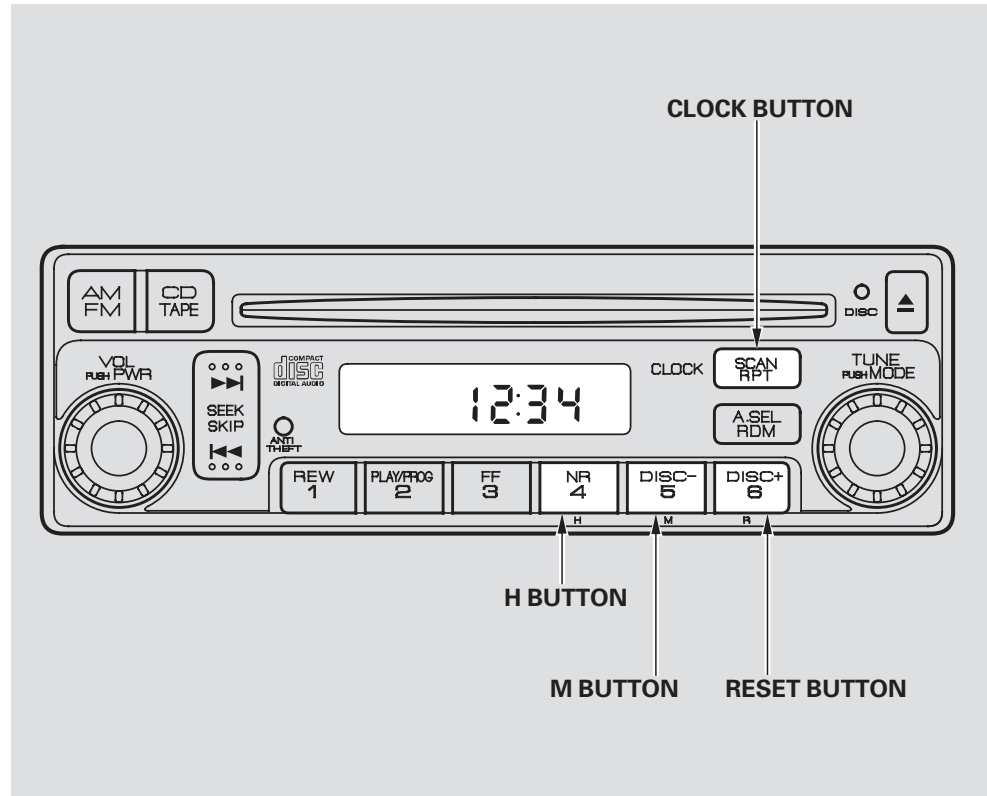

Before you begin driving your vehicle, you should know what gasoline to use and how to check the levels of important fluids. You also need to know how to properly store luggage or packages. The information in this section will help you. If you plan to add any accessories to your vehicle, please read the information in this section first.

Break-in Period	94
Fuel Recommendation	94
Service Station Procedures	95
Refueling.....	95
Opening and Closing the Hood	96
Oil Check.....	97
Engine Coolant Check	98
Fuel Economy	99
Improving Fuel Economy	99
Accessories and Modifications	101
Accessories.....	101
Modifying Your Vehicle.....	102
Carrying Cargo	103
Air Intake.....	106

Break-in Period, Fuel Recommendation

Break-in Period

Help assure your vehicle's future reliability and performance by paying extra attention to how you drive during the first 600 miles (1,000 km). During this period:

- Avoid full-throttle starts and rapid acceleration.
- Do not change the oil until the scheduled maintenance time.
- Avoid hard braking for the first 200 miles (300 km).

You should also follow these recommendations with an overhauled or exchanged engine, or when the brakes are replaced.

Fuel Recommendation

Your vehicle is designed to operate on unleaded gasoline with a pump octane number of 86 or higher. Use of a lower octane gasoline can cause occasional metallic knocking noises in the engine and will result in decreased engine performance.

We recommended using a quality gasoline containing detergent additives that help prevent fuel system and engine deposits.

In addition, in order to maintain good performance, fuel economy, and emissions control, we strongly recommend, in areas where it is available, the use of gasoline that does NOT contain manganese-based fuel additives such as MMT.

Use of gasoline with these additives may adversely affect performance, and cause the Malfunction Indicator Lamp on your instrument panel to come on. If this happens, contact your dealer for service.

Some gasoline today is blended with oxygenates such as ethanol or MTBE. Your vehicle is designed to operate on oxygenated gasoline containing up to 10 percent ethanol by volume and up to 15 percent MTBE by volume. Do not use gasoline containing methanol.

If you notice any undesirable operating symptoms, try another service station or switch to another brand of gasoline.

For further important fuel-related information, please refer to your **Quick Start Guide**.

Refueling

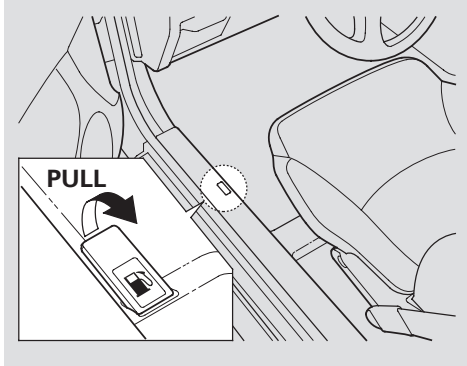

1. Park with the driver's side closest to the service station pump.
2. Open the fuel fill door by pulling on the handle to the left of the driver's seat.

⚠ WARNING

Gasoline is highly flammable and explosive. You can be burned or seriously injured when handling fuel.

- Stop the engine and keep heat, sparks, and flame away.
- Handle fuel only outdoors.
- Wipe up spills immediately.

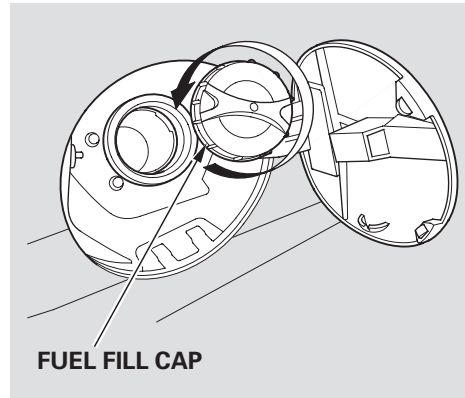

3. Remove the fuel fill cap slowly. You may hear a hissing sound as pressure inside the tank escapes.
4. Stop filling the tank after the fuel nozzle automatically clicks off. Do not try to "top off" the tank. Leave some room for the fuel to expand with temperature changes.

If the fuel nozzle keeps clicking off even though the tank is not full, there may be a problem with your vehicle's fuel vapor recovery system. The system helps keep fuel vapors from going into the atmosphere. Consult your dealer.

CONTINUED

Service Station Procedures

5. Screw the fuel fill cap back on until it clicks at least three times. If you do not properly tighten the cap, the Malfunction Indicator Lamp may come on (see page 180).
6. Push the fuel fill door closed until it latches.

Opening and Closing the Hood

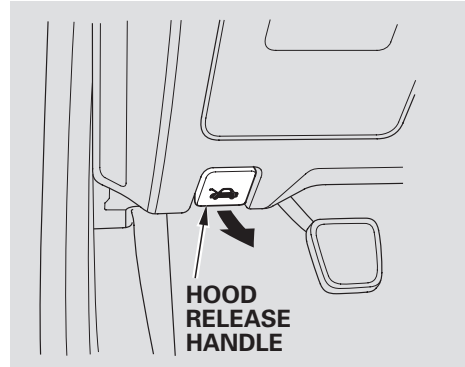

1. Park the vehicle, and set the parking brake. Pull the hood release handle located under the lower left corner of the dashboard. The hood will pop up slightly.

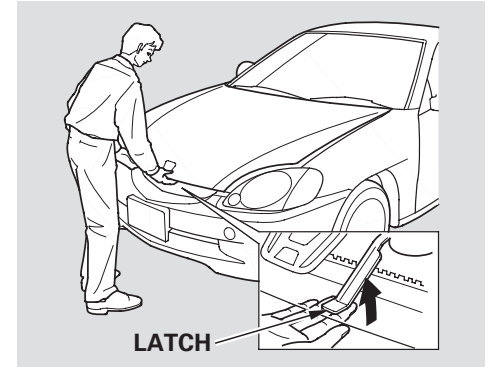

2. Put your fingers under the front edge of the hood near the center. Slide your hand to your left until you feel the hood latch handle. Push this handle up until it releases the hood. Lift up the hood.

If the hood latch handle moves stiffly, or if you can open the hood without lifting the handle, the mechanism should be cleaned and lubricated.

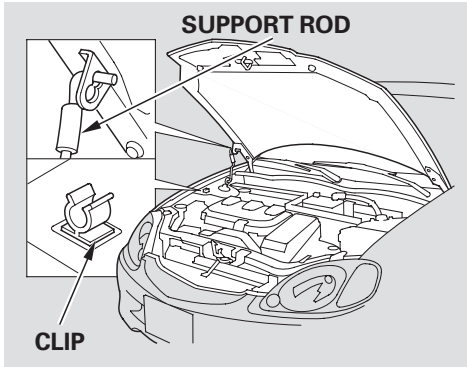

3. Pull the support rod out of its clip, and insert the end into the designated hole in the hood.

To close the hood, lift it up slightly to remove the support rod from the hole. Put the support rod back into its holding clip. Lower the hood to about a foot (30 cm) above the fender, then let it drop. Make sure it is securely latched.

Oil Check

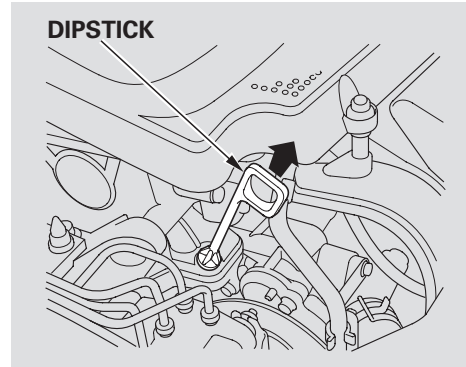

Wait a few minutes after turning the engine off before you check the oil.

1. Remove the dipstick (orange handle).
2. Wipe off the dipstick with a clean cloth or paper towel.
3. Insert it all the way back in its hole.

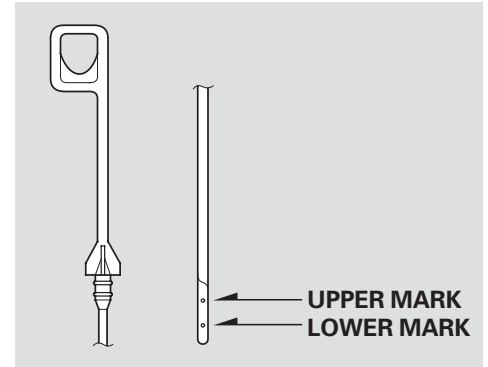

4. Remove the dipstick again, and check the level. It should be between the upper and lower marks.

If it is near or below the lower mark, see **Adding Oil** on page [135](#).

Service Station Procedures

Engine Coolant Check

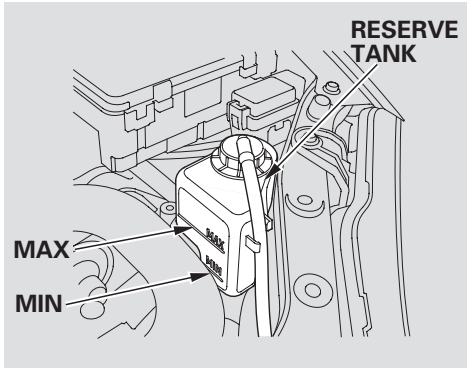

Look at the coolant level in the radiator reserve tank. Make sure it is between the MAX and MIN lines. If it is below the MIN line, see **Adding Engine Coolant** on page [139](#) for information on adding the proper coolant.

Refer to **Owner's Maintenance Checks** on page [128](#) for information about checking other items on your vehicle.

Improving Fuel Economy

- Always maintain your vehicle according to the maintenance schedule. See **Owner's Maintenance Checks** on page [128](#).

For example, an underinflated tire causes more “rolling resistance,” which uses more fuel.

The build-up of snow or mud on your vehicle's underside adds weight and rolling resistance. Frequent cleaning helps your fuel mileage and reduces the chance of corrosion.

- The fuel efficient, low-viscosity 0W-20 oil recommended for your Insight is formulated to help the engine use less fuel. This oil is available at your dealer.

- Drive moderately. Rapid acceleration, abrupt cornering, and hard braking use more fuel.
- Always drive in the highest gear possible.
- Try to maintain a constant speed. Every time you slow down and speed up, your vehicle uses extra fuel.
- Shift Up and Shift Down indicators (5-speed manual transmission only) on the instrument panel show when to shift to a higher or lower gear, so you will keep the engine operating in its most economical range.

- Wind resistance causes vehicles to use more fuel at higher speeds. Driving at moderate speeds on the highway also reduces wind resistance and conserves fuel.
- The current fuel mileage display is available to drive appropriately and save the fuel.
- Driving in ECON mode, the A/C off, and using the Auto Idle Stop function is the most effective way to get the best fuel economy.
- Combine several short trips into one.

CONTINUED

Fuel Economy

- The air conditioning puts an extra load on the engine which makes it use more fuel. Use the fresh-air ventilation when possible.

If air conditioning is needed, you can save some fuel by using the A/C in “ECON” mode. When the outside temperature is above 41°F (5°C), this mode allows the Auto Idle Stop function to shut off the engine when the vehicle is stopped, resulting in fuel savings.

You may notice that using the A/C causes a greater drop in fuel economy. Although the extra fuel used by the A/C load on the engine is no greater than other vehicles, it is more noticeable because of your Insight’s excellent fuel mileage.

Modifying your vehicle, or installing some non-Honda accessories, can make your vehicle unsafe. Before you make any modifications or add any accessories, be sure to read the following information.

Accessories

Your dealer has Honda accessories that allow you to personalize your vehicle. These accessories have been designed and approved for your vehicle, and are covered by warranty.

Although non-Honda accessories may fit on your vehicle, they may not meet factory specifications, and could adversely affect your vehicle's handling and stability.

WARNING

Improper accessories or modifications can affect your vehicle's handling, stability, and performance, and cause a crash in which you can be hurt or killed.

Follow all instructions in this owner's manual regarding accessories and modifications.

When properly installed, cellular phones, alarms, two-way radios, and low-powered audio systems should not interfere with your vehicle's computer controlled systems, such as your airbags and anti-lock brakes.

Before installing any accessory:

- Make sure the accessory does not obscure any lights, or interfere with proper vehicle operation or performance.
- Be sure electronic accessories do not overload electrical circuits (see page 185) or interfere with proper operation.
- Have the installer contact your dealer for assistance before installing any electronic accessory. If possible, have your dealer inspect the final installation.

Accessories and Modifications

Modifying Your Vehicle

Removing parts from your vehicle, or replacing components with non-Honda components could seriously affect your vehicle's handling, stability, and reliability.

Some examples are:

- Lowering your vehicle with a non-Honda suspension kit that significantly reduces ground clearance can allow the undercarriage to hit speed bumps or other raised objects, which could cause the airbags to deploy.
- Raising your vehicle with a non-Honda suspension kit can affect the handling and stability.
- Non-Honda wheels, because they are a universal design, can cause excessive stress on suspension components.

- Larger or smaller wheels and tires can interfere with the operation of your vehicle's anti-lock brakes and other systems.
- Modifying your steering wheel or any other part of your vehicle's safety systems could make the systems ineffective.

If you plan to modify your vehicle, consult your dealer.

Carrying Cargo

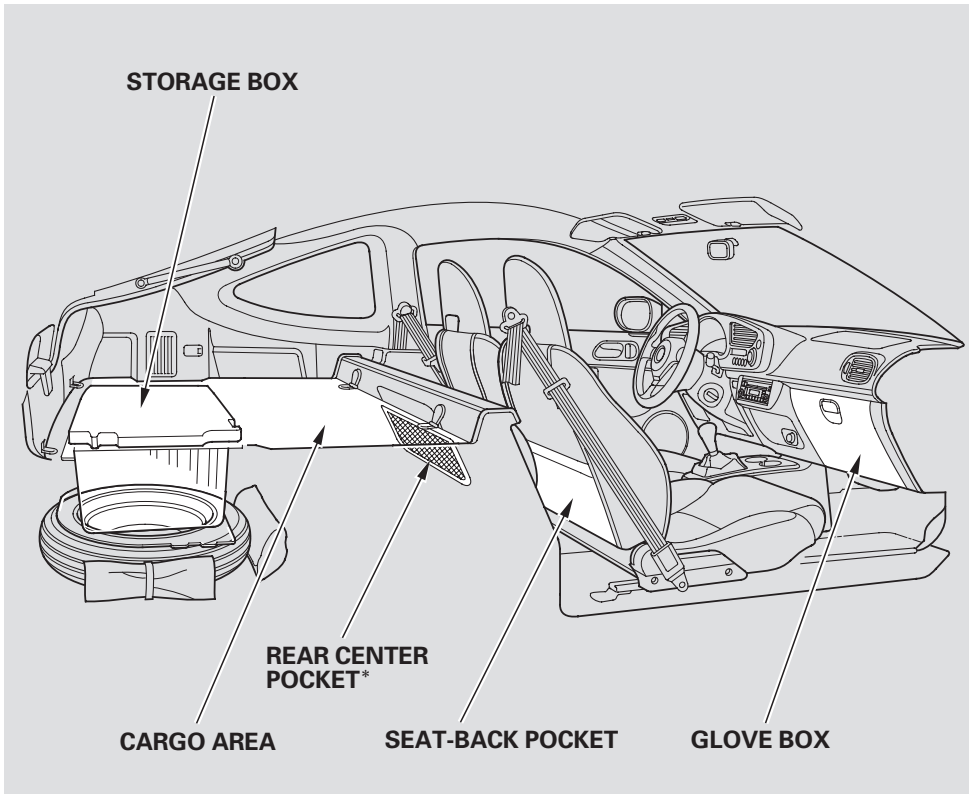

Your vehicle has several convenient storage areas:

- Glove box
- Seat-back pocket
- Storage box
- Cargo area
- Rear center pocket

However, carrying too much cargo, or improperly storing it, can affect your vehicle's handling, stability, stopping distance, and tires, and make it unsafe. Before carrying any type of cargo, be sure to read the following pages.

* Do not store large objects in the rear center pocket. The objects in the pocket will be broken when you adjust the seats backwards.

Carrying Cargo

Load Limits

The maximum load for your vehicle is 400 lbs (185 kg). This figure includes the total weight of all occupants, cargo, and accessories.

WARNING

Overloading or improper loading can affect handling and stability and cause a crash in which you can be hurt or killed.

Follow all load limits and other loading guidelines in this manual.

Steps for determining correct load limit:

1. Locate the statement, “the combined weight of occupants and cargo should never exceed 400 lbs” on your vehicle’s placard. [The placard is on the driver’s doorjamb.]
2. Determine the combined weight of the driver and passenger that will be riding in your vehicle.
3. Subtract the combined weight of the driver and passenger from 400 pounds or 185 kilograms.
4. The resulting figure equals the available amount of cargo and luggage load capacity. For example, if the maximum load is 400 lbs and there will be two 150 lb. passengers in your vehicle, the amount of available cargo and luggage load capacity is 100 lbs. [400 – 300 (2 × 150) = 100 lbs.]
5. Determine the combined weight of luggage and cargo being loaded on the vehicle. That weight may not safely exceed the available cargo and luggage load capacity in step 4.

In addition, the total weight of the vehicle, all passengers, accessories, and cargo must not exceed the Gross Vehicle Weight Rating (GVWR) or the Gross Axle Weight Rating (GAWR). Both are on a label on the driver’s doorjamb.

Carrying Items in the Passenger Compartment

- Store or secure all items that could be thrown around and hurt someone during a crash.
- Be sure items placed on the floor behind the seats cannot roll under the seats and interfere with the pedals or seat operation.
- Keep the glove box closed while driving. If it is open, a passenger could injure their knees during a crash or sudden stop.

Carrying Cargo in the Cargo Area

- Distribute cargo evenly on the floor of the cargo area, placing the heaviest items on the bottom and as far forward as possible.
- Tie down items that could be thrown about the vehicle during a crash or sudden stop.
- Do not stack objects higher than the tops of the seat-backs. They could block your view and be thrown about the vehicle during a crash or sudden stop.

- If you carry large items that prevent you from closing the hatch, exhaust gas can enter the passenger area. To avoid the possibility of **carbon monoxide poisoning**, follow the instructions on page [38](#).
- The floor of the storage box is made of a soft plastic material. It is not strong enough to stand heavy goods on it.

Carrying Cargo

Cargo Hooks

To secure the cargo, you can use the four cargo hooks on the cargo area. The illustration shows the location of each cargo hook.

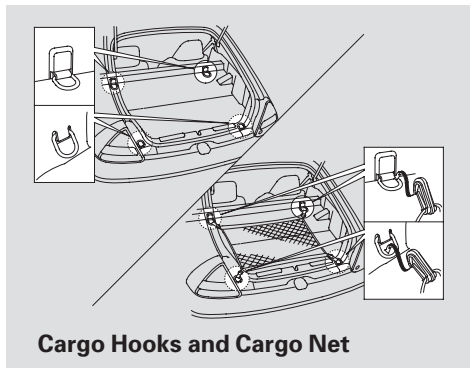

Cargo Hooks and Cargo Net

Cargo Net

The cargo net can be used to help hold down light items in the cargo area. The cargo net may not prevent heavy items from being thrown forward in a crash or a sudden stop. Cargo secured with this net should not exceed 22 lbs (10 kg). Heavy items should be secured to the cargo area floor with tie-downs or cinch straps attached to the cargo hooks.

Air Intake

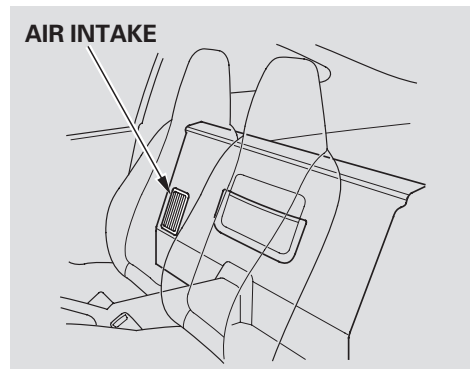

The air intake for the IMA battery is located behind the passenger's seat. Do not block this air intake with any cargo.

Do not spill any liquids over the air intake or put any small foreign objects in it. This may damage the IMA battery and the power control unit.

This section gives you tips on starting the engine under various conditions, and how to operate the manual and automatic transmissions. It also includes important information on parking your vehicle, and the braking system.

Preparing to Drive	108
Starting the Engine.....	109
Manual Transmission.....	110
Shift Up/Shift Down	
Indicators.....	111
Auto Idle Stop.....	111
Automatic Transmission (CVT) ..	113
Continuously Variable	
Transmission (CVT)	113
Shift Lever Position	
Indicators.....	113
Shifting.....	114
Shift Lock Release.....	117
Auto Idle Stop.....	118
Parking.....	120
Braking System.....	121
Brake System Design.....	121
Brake Wear Indicators.....	121
Anti-lock Brakes (ABS)	122
ABS Indicator	122
Towing a Trailer	123

Preparing to Drive

You should do the following checks and adjustments before you drive your vehicle.

1. Make sure all windows, mirrors, and outside lights are clean and unobstructed. Remove frost, snow, or ice.
2. Check that the hood is fully closed.
3. Visually check the tires. If a tire looks low, use a gauge to check its pressure.
4. Check that any items you may be carrying are stored properly or fastened down securely.
5. Check the seat adjustment (see page [66](#)).
6. Check the adjustment of the inside and outside mirrors (see page [68](#)).
7. Make sure the doors and the hatch are securely closed and locked.
8. Fasten your seat belt. Check that your passengers have fastened their seat belts (see page [14](#)).
9. When you start the engine, check the gauges and indicators in the instrument panel (see page [43](#)).

1. Apply the parking brake.
2. In cold weather, turn off all electrical accessories to reduce the drain on the battery.
3. *Manual Transmission:*
Push the clutch pedal down all the way. START (III) does not function unless the clutch pedal is pressed.

Automatic Transmission (CVT):
Make sure the shift lever is in Park. Press on the brake pedal.

4. Without touching the accelerator pedal, turn the ignition key to the START (III) position. Do not hold the key in START for more than 15 seconds at a time. If the engine does not start right away, pause for at least 10 seconds before trying again.

NOTICE

*The immobilizer system protects your vehicle from theft. If an improperly-coded key (or other device) is used, the engine's fuel system is disabled. See **Immobilizer System** on page 60 .*

5. If the engine does not start within 15 seconds, or starts but stalls right away, repeat step 4 with the accelerator pedal pressed halfway down. If the engine starts, release pressure on the accelerator pedal so the engine does not race.
6. If the engine fails to start, press the accelerator pedal all the way down and hold it there while starting to clear flooding. If the engine still does not start, return to step 5.

NOTICE

The engine is harder to start in cold weather. Also, the thinner air found at altitudes above 8,000 feet (2,400 meters) adds to this problem.

Manual Transmission

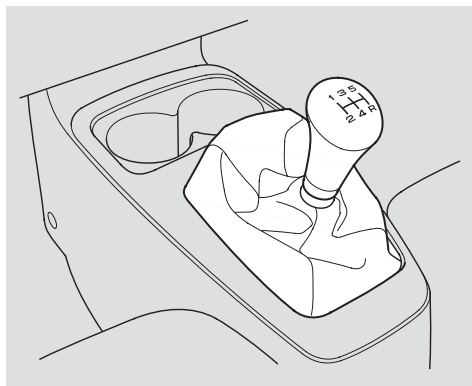

The manual transmission is synchronized in all forward gears for smooth operation. It has a lockout so you cannot shift directly from Fifth to Reverse. When shifting up or down, make sure you push the clutch pedal down all the way, shift to the next gear, and let the pedal up gradually. When you are not shifting, do not rest your foot on the clutch pedal. This can cause your clutch to wear out faster.

Come to a full stop before you shift into Reverse. You can damage the transmission by trying to shift into Reverse with the vehicle moving. Push down the clutch pedal, and pause for a few seconds before shifting into Reverse, or shift into one of the forward gears for a moment. This stops the gears so they won't "grind."

When slowing down, you can get extra braking from the engine by shifting to a lower gear. This extra braking can help you maintain a safe speed and prevent your brakes from overheating while going down a steep hill. Before downshifting, make sure the engine speed will not go into the tachometer's red zone in the lower gear.

WARNING

Rapid slowing or speeding-up can cause loss of control on slippery surfaces. If you crash, you can be injured.

Use extra care when driving on slippery surfaces.

Shift Up/Shift Down Indicators

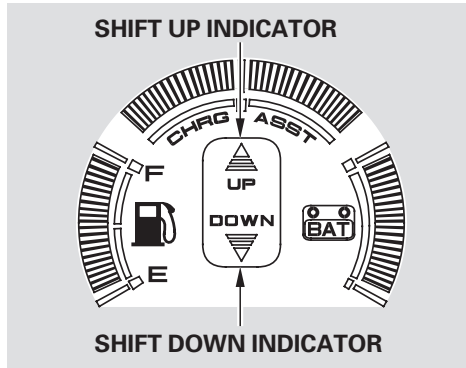

The Shift Up or Shift Down indicator will come on at the best time to shift to a higher or lower gear for the best fuel economy. You can achieve the best fuel economy by accelerating and decelerating slowly, and shifting up when prompted.

The Shift Down indicator prompts you to shift to a lower gear when you are climbing a hill faster than 12 mph (19 km/h), losing speed, and pressing on the accelerator pedal.

Road and traffic conditions may require you to shift at times other than those indicated.

Engine Speed Limiter

If you exceed the maximum speed for the gear you are in, the engine speed will enter into the tachometer's red zone. If this occurs, you may feel the engine cut in and out. This is caused by a limiter in the engine's computer controls. The engine will run normally when you reduce the RPM below the red zone.

Before downshifting, make sure the engine will not go into the tachometer's red zone.

Auto Idle Stop

To maximize fuel economy, under certain conditions, the engine will shut off when you come to a stop. Those conditions are:

- The engine coolant is nearly up to normal operating temperature.
- The vehicle's speed is below 19 mph (30 km/h) and you are pressing on the brake pedal to come to a stop.
- You depress the clutch pedal.
- You are not pressing on the accelerator pedal.
- The IMA battery is sufficiently charged (at least 1/3 on the battery level gauge).
- The A/C is off, or in ECON mode, and the outside temperature is above 41°F (5°C) (see page 75).

CONTINUED

Manual Transmission

- There is adequate vacuum reserve for the power brakes.

The engine will start again automatically when you shift to first gear. There is no need to start the engine with the ignition switch.

It is recommended that you shift to Neutral and release the clutch pedal while stopped. Sitting with the clutch pedal depressed and the shift lever in gear will cause the engine to continue running, defeating the fuel economy benefits of the Auto Idle Stop function.

During Auto Idle Stop, the IMA charge and power brake vacuum reserve is monitored by the system. If either drops below a desired level, and the shift lever is in Neutral, the engine will restart so it can recharge the IMA battery or replenish the vacuum supply.

Auto Idle Stop Indicator

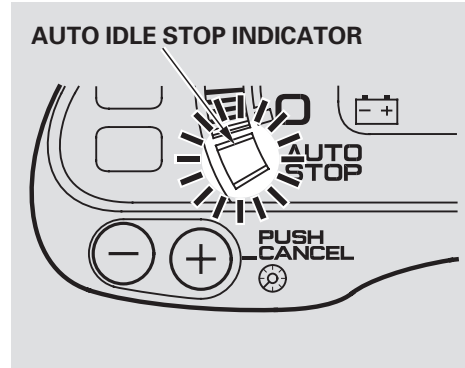

When the indicator is off:

Auto Idle Stop is not active.

When the indicator is on:

Auto Idle Stop is active.

The clutch pedal is depressed.

The transmission is not in gear.

When the indicator is blinking:

Auto Idle Stop is active.

The clutch is not depressed.

You cannot restart the engine.

You will hear a chime if the door is open.

Continuously Variable Transmission (CVT)

U.S. model

Honda's Continuously Variable Transmission's unique design provides a smooth, constant flow of power. It is electronically controlled for more precise operation and better fuel economy.

Shift Lever Position Indicators

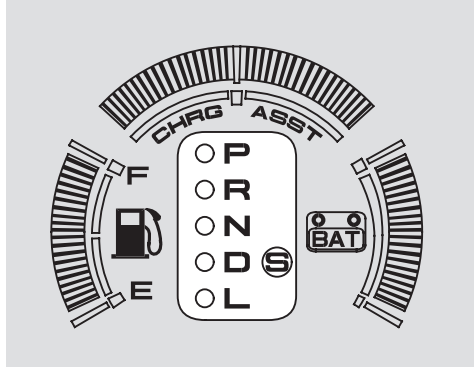

These indicators on the instrument panel show which position the shift lever is in.

The “D” indicator comes on for a few seconds when you turn the ignition switch to ON (II). If it flashes while driving (in any shift position), it indicates a possible problem in the transmission.

If the malfunction indicator lamp comes on along with the “D” indicator, there is a problem in the automatic transmission control system. Avoid rapid acceleration, and have the transmission checked by your dealer as soon as possible.

Automatic Transmission (CVT)

Shifting

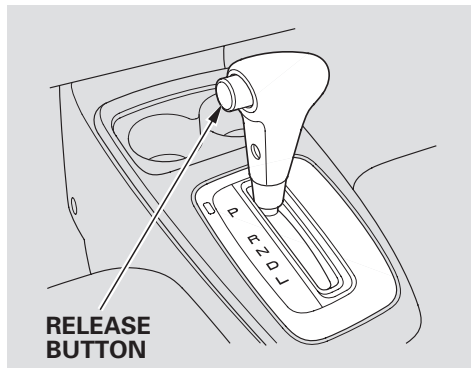

To shift from any position, press firmly on the brake pedal and press the release button on the side of the shift lever. You cannot shift out of Park when the ignition switch is in the LOCK (0) or ACCESSORY (I) position.

To shift from:	Do this:
P to R	Press the brake pedal and press the release button on the lever.
R to P N to R D to L	Press the release button on the lever.
N to D D to N L to D R to N	Move the lever.

Park (P) — This position mechanically locks the transmission. Use Park whenever you are turning off or starting the engine. To shift out of Park, you must press on the brake pedal and have your foot off the accelerator pedal. Press the release button on the side of the shift lever to move it.

If you have done all of the above and still cannot move the lever out of Park, see **Shift Lock Release** on page [117](#).

You must also press the release button to shift into Park. To avoid transmission damage, come to a complete stop before shifting into Park. The shift lever must be in Park before you can remove the key from the ignition switch.

Reverse (R) — Press the brake pedal and press the release button on the side of the shift lever to shift from Park to Reverse. To shift from Reverse to Neutral, come to a complete stop and then shift.

Neutral (N) — Use Neutral if you need to restart a stalled engine or if it is necessary to stop briefly with the engine idling. Always shift to the Park position if you need to leave the vehicle for any reason. Press on the brake pedal when you are moving the shift lever from Neutral to another position.

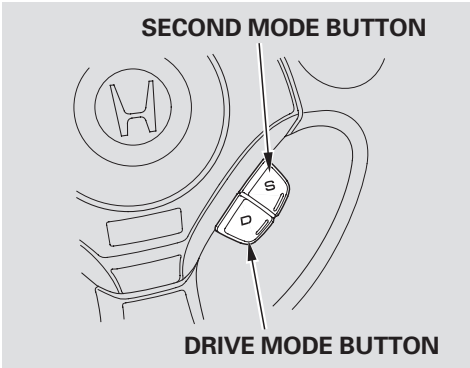

Drive (D) – Use this position for normal driving. The drive position has two modes, Drive (D) and Second (S). You can select the desired mode with the two select buttons on the steering wheel. The “D” indicator remains lit in either mode.

Drive Mode – Use this mode for everyday driving. The transmission automatically adjusts to keep the engine at the best speed for driving conditions. To help the engine warm up faster, the transmission will select ratios that allow the engine to run at higher speeds when it is cold.

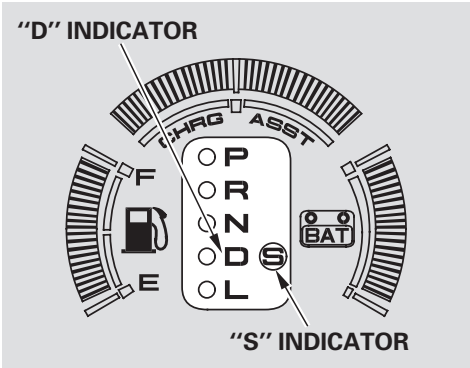

Second (S) Mode – In this mode, the transmission selects a wider range of ratios to give better acceleration. Use this mode for driving up or downhill. Along with the “D” indicator, the “S” indicator comes on as a reminder.

CONTINUED

Automatic Transmission (CVT)

You can switch into and out of Second mode with the ignition switch ON (II) and the shift lever in D position. If you turn the ignition switch to ACCESSORY (I) in Second mode, the mode is switched to Drive.

The “S” indicator also comes on for a few seconds when you turn the ignition switch to ON(II).

Low (L) — To shift to Low, press the release button on the side of the shift lever. Use Low to get more power when climbing, and for maximum engine braking when going down steep hills.

For faster acceleration when in D or L, the transmission will automatically “kick down” to a lower range of ratios when you push the accelerator pedal to the floor.

Engine Speed Limiter

If you exceed the maximum speed for the gear you are in, the engine speed will enter into the tachometer’s red zone. If this occurs, you may feel the engine cut in and out. This is caused by a limiter in the engine’s computer controls. The engine will run normally when you reduce the RPM below the red zone.

Shift Lock Release

This allows you to move the shift lever out of Park if the normal method of pushing on the brake pedal and pressing the release button does not work.

1. Set the parking brake.
2. Make sure the ignition switch is in the LOCK (0) position.
3. Put a cloth on the edge of the Shift Lock Release slot cover. Using a small flat-tipped screwdriver or finger nail file, carefully pry on the edge of the cover to remove it.

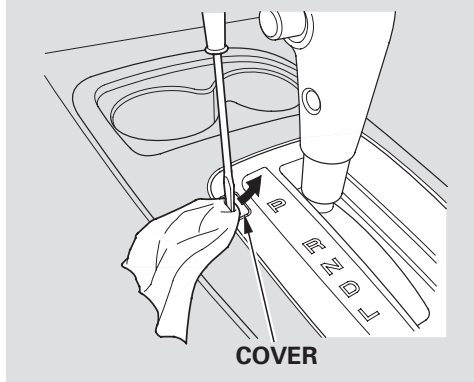

4. Insert the key in the Shift Lock Release slot.
5. Push down on the key while you press the release button on the shift lever and move the shift lever out of Park to Neutral.

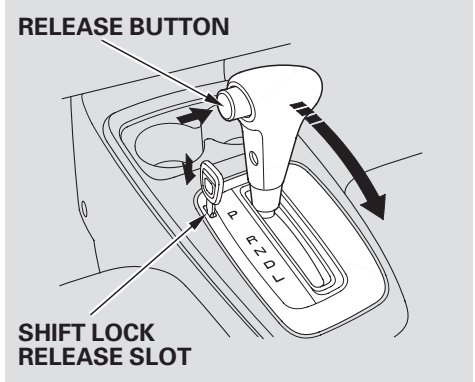

6. Remove the key from the Shift Lock Release slot, then reinstall the cover. Make sure the notch on the cover is on the left side. Press the brake pedal, and restart the engine.

If you need to use the Shift Lock Release, it means your vehicle is developing a problem. Have the vehicle checked by your dealer.

Automatic Transmission (CVT)

Auto Idle Stop

To maximize fuel economy, your Insight has an Auto Idle Stop function. Under certain conditions, the engine will shut off when you come to a stop. Those conditions are:

- The engine coolant is nearly up to normal operating temperature.
- The shift lever is in D or N.
- You are not pressing on the accelerator pedal.
- The IMA battery is sufficiently charged (at least 1/3 on the Battery Level Gauge).
- The A/C is off, or in ECON mode, and the outside temperature is above 41°F (5°C) (see page [75](#)).

- There is adequate vacuum reserve for the power brakes.

When these conditions are met, the engine will shut off as you are braking to a stop and the vehicle speed goes below 5 mph (8 km/h).

The engine will start again when you release the brake pedal. It will also restart, even if you are still pressing the brake pedal, under these conditions:

- You move the shift lever from D or N to R, L, or P.
- You press the accelerator pedal.
- You are on an incline, and the vehicle begins rolling.

During Auto Idle Stop, the IMA charge and power brake vacuum reserve is monitored by the system. If the vacuum reserve drops below an optimal level, the engine will restart to replenish the vacuum supply. If the IMA charge drops below an optimal level and the shift lever is in Neutral or Park (P), the engine will restart to recharge the IMA battery.

Auto Idle Stop Indicator

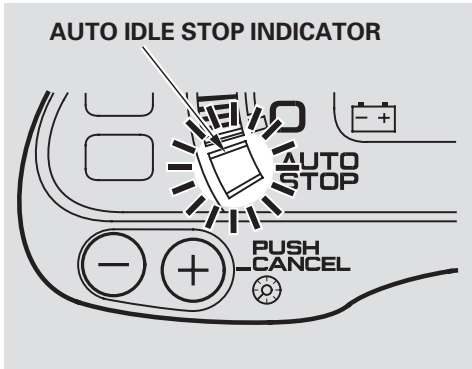

The indicator blinks as a reminder that the engine has stopped because of the Auto Idle Stop function. You cannot restart the engine with the ignition switch when this indicator is blinking.

If you open the driver's door when Auto Stop is active, the indicator will blink and you will hear a chime. The chime will stop when you close the door.

Always turn the ignition switch to LOCK (0) and remove the key if you are getting out of the vehicle.

Parking

Always use the parking brake when you park your vehicle. Make sure the parking brake is set firmly or your vehicle may roll if it is parked on an incline.

If your vehicle has an automatic transmission, set the parking brake before you put the transmission in Park. This keeps the vehicle from moving and putting pressure on the parking mechanism in the transmission.

Parking Tips

- Make sure the windows are closed.
- Turn off the lights.
- Place any packages, valuables, etc. in the storage box or take them with you.
- Lock the doors and the hatch with the key or the remote transmitter.
- Never park over dry leaves, tall grass, or other flammable materials. The hot three way catalytic converter could cause these materials to catch on fire.
- If the vehicle is facing uphill, turn the front wheels away from the curb. If you have a manual transmission, put it in first gear.
- If the vehicle is facing downhill, turn the front wheels toward the curb. If you have a manual transmission, put it in reverse gear.
- Make sure the parking brake is fully released before driving away. Driving with the parking brake partially set can overheat or damage the rear brakes.

Your vehicle is equipped with front disc brakes. The brakes on the rear wheels are drum. A power assist helps reduce the effort needed on the brake pedal. The ABS helps you retain steering control when braking very hard.

Resting your foot on the pedal keeps the brakes applied lightly, builds up heat, and reduces their effectiveness. It also keeps your brake lights on all the time, confusing drivers behind you.

Constant application of the brakes when going down a long hill builds up heat and reduces their effectiveness. Use the engine to assist the brakes by taking your foot off the accelerator and downshifting to a lower gear.

Check the brakes after driving through deep water. Apply the brakes moderately to see if they feel normal. If not, apply them gently and frequently until they do. Be extra cautious in your driving.

Braking System Design

The hydraulic system that operates the brakes has two separate circuits. Each circuit works diagonally across the vehicle (the left-front brake is connected with the right-rear brake, etc.). If one circuit should develop a problem, you will still have braking at two wheels.

Brake Wear Indicators

If the brake pads need replacing, you will hear a distinctive, metallic screeching sound when you apply the brake pedal. If you do not have the brake pads replaced, they will screech all the time. It is normal for the brakes to occasionally squeal or squeak when you apply them.

Anti-lock Brakes (ABS)

The anti-lock brake system (ABS) helps prevent the brakes from locking up, and helps you retain steering control by pumping the brakes rapidly, much faster than a person can do it.

You should never pump the brake pedal; this defeats the purpose of the ABS. Let the ABS work for you by always keeping firm, steady pressure on the brake pedal as you steer away from the hazard. This is sometimes referred to as “stomp and steer.”

You will feel a pulsation in the brake pedal when the ABS activates, and you may hear some noise. This is normal: it is the ABS rapidly pumping the brakes. On dry pavement, you will need to press on the brake pedal very hard before the ABS activates. However, you may feel the ABS activate immediately if you are trying to stop on snow or ice.



ABS Indicator

If the ABS indicator comes on, the anti-lock function of the braking system has shut down. The brakes still work like a conventional system, but without anti-lock. You should have your dealer inspect your vehicle as soon as possible.

Important Safety Reminders

ABS does not reduce the time or distance it takes to stop the vehicle. It only helps with the steering control during braking.

ABS will not prevent a skid that results from changing direction abruptly, such as trying to take a corner too fast or making a sudden lane change.

ABS cannot prevent the loss of stability. Always steer moderately when you are braking hard. Severe or sharp steering wheel movement can still cause your vehicle to veer into oncoming traffic or off the road.

A vehicle with ABS may require a longer distance to stop on loose or uneven surfaces, such as gravel or snow, than a vehicle without anti-lock.

Towing a Trailer

Your vehicle is not designed to tow a trailer, attempting to do so can void your warranties.

This section explains why it is important to keep your vehicle well maintained and how to follow basic maintenance safety precautions.

This section also includes Maintenance Schedules for normal driving and severe driving conditions, a Maintenance Record, and instructions for simple maintenance tasks you may want to take care of yourself.

If you have the skills and tools to perform more complex maintenance tasks on your vehicle, you may want to purchase the Service Manual. See page 207 for information on how to obtain a copy, or see your dealer.

Maintenance Safety	126	Tire Maintenance	158
Maintenance Schedule	127	Tire Rotation	159
Maintenance Record	131	Replacing Tires	159
Fluid Locations.....	134	Wheels and Tires	
Adding Engine Oil	135	Specifications	160
Recommended Engine Oil.....	135	Winter Driving	160
Synthetic Oil.....	136	Snow Tires.....	161
Engine Oil Additives	136	Tire Chains.....	161
Changing the Oil and Filter	136	Checking the Battery	162
Engine Coolant.....	139	Vehicle Storage.....	163
Windshield Washers	141		
Transmission Fluid.....	142		
Automatic Transmission			
(CVT)	142		
Manual Transmission	143		
Brake and Clutch Fluid.....	144		
Lights	146		
Seat Belts	151		
Floor Mats	151		
Dust and Pollen Filter	152		
Roof Antenna	152		
Rear Wheel Skirt	153		
Wiper Blades	153		
Tires	156		
Inflation Guidelines	156		
Tire Inspection.....	158		

Maintenance Safety

All service items not detailed in this section should be performed by a certified technician or other qualified mechanic.

Important Safety Precautions

To eliminate potential hazards, read the instructions before you begin, and make sure you have the tools and skills required.

- Make sure your vehicle is parked on level ground, the parking brake is set, and the engine is off.
- To clean parts, use a commercially available degreaser or parts cleaner, not gasoline.
- To reduce the possibility of fire or explosion, keep cigarettes, sparks, and flames away from the battery and all fuel-related parts.
- Wear eye protection and protective clothing when working with the battery or compressed air.

WARNING

Improperly maintaining this vehicle, or failing to correct a problem before driving can cause a crash in which you can be seriously hurt or killed.

Always follow the inspection and maintenance recommendations and schedules in this owner's manual.

Potential Vehicle Hazards

- **Carbon Monoxide poison from engine exhaust.** Be sure there is adequate ventilation whenever you operate the engine.
- **Burns from hot parts.** Let the engine and exhaust system cool before touching any parts.

- **Injury from moving parts.** Do not run the engine unless instructed to do so.

WARNING

Failure to properly follow maintenance instructions and precautions can cause you to be seriously hurt or killed.

Always follow the procedures and precautions in this owner's manual.

Some of the most important safety precautions are given here. However, we cannot warn you of every conceivable hazard that can arise in performing maintenance. Only you can decide whether or not you should perform a given task.

The maintenance schedule assumes you will use your vehicle as normal transportation for passengers and their possessions. You should also follow these recommendations:

- Avoid exceeding your vehicle's load limit. This puts excess stress on the engine, brakes, and many other vehicle parts. The load limit is shown on the tire information label on the driver's doorjamb.
- Operate your vehicle on reasonable roads within the legal speed limit.
- Drive your vehicle regularly over a distance of several miles (kilometers).
- Always use unleaded gasoline with the proper octane rating (see page 94).

Which Schedule to Follow:

Service your vehicle according to the time and mileage periods on one of the Maintenance Schedules on the following pages.

U.S. Owners — Follow the Maintenance Schedule for Severe Conditions if you drive your vehicle MAINLY under one or more of the following conditions.

- Driving less than 5 miles (8 km) per trip or, in freezing temperatures, driving less than 10 miles (16 km) per trip.
- Driving in extremely hot [over 90°F (32°C)] conditions.
- Extensive idling or long periods of stop and go driving.

- Driving in mountainous conditions.
- Driving on muddy, dusty, or de-iced roads.

NOTE: If you only OCCASIONALLY drive under a “severe” condition, you should follow the Maintenance Schedule for Normal Conditions.

Canadian Owners — Follow the Maintenance Schedule for Severe Conditions.

Maintenance Schedule

Servicing Your Vehicle

Your authorized dealer knows your vehicle best and can provide competent, efficient service. However, service at a dealer is not mandatory to keep your warranties in effect. Maintenance may be done by any qualified service facility or skilled person to keep your warranties in effect. Keep all the receipts as proof of completion, and have the person who does the work fill out the Maintenance Record. Check your warranty booklet for more information.

We recommend the use of Honda parts and fluids whenever you have maintenance done.

U.S. Vehicles: **Maintenance, replacement, or repair of emissions control devices and systems may be done by any automotive repair establishment or individual using parts that are “certified” to EPA standards.**

According to state and federal regulations, failure to perform maintenance on the items marked with # will not void your emissions warranties. However, all maintenance services should be performed at the recommended time or mileage period to ensure long-term reliability.

Owner’s Maintenance Checks

You should check the following items at the specified intervals. If you are unsure of how to perform any check, turn to the appropriate page listed.

- Engine oil level — Check every time you fill the fuel tank. See page [97](#) .
- Engine coolant level — Check the radiator reserve tank every time you fill the fuel tank. See page [98](#) .
- Automatic transmission (CVT) — Check the fluid level monthly. See page [142](#) .
- Brakes — Check the fluid level monthly. See page [145](#) .
- Tires — Check the tire pressure monthly. Examine the tread for wear and foreign objects. See page [156](#) .
- Lights — Check the operation of the headlights, parking lights, taillights, high-mount brake light, turn signals, brake lights, and license plate light monthly. See page [146](#) .

Service the items listed at the indicated distance (or time, if given).											
	miles x 1,000	15	30	45	60	75	90	105	120	135	150
	km x 1,000	24	48	72	96	120	144	168	192	216	240
Check engine oil and coolant	Check oil and coolant at each fuel stop										
Check tires	Check inflation and condition once a month										
Replace engine oil	Every 7,500 miles (12,000 km) or every 1 year, whichever comes first										
Rotate tires (follow pattern on page 159)	Every 7,500 miles (12,000 km)										
Replace engine oil filter Check front and rear brake wear Check parking brake adjustment Inspect the following items: Tie-rod ends, steering gearbox, and boots Suspension components Driveshaft boots Brake hoses and lines (including ABS) All fluid levels and condition of fluids Exhaust system [#] Fuel lines and connections [#]	Every 15,000 miles (24,000 km) or every 1 year, whichever comes first										
Inspect drive belts	Every 30,000 miles (48,000 km) or every 2 years, whichever comes first										
Replace dust and pollen filter											
Replace air cleaner element			●		●		●		●		●
Replace spark plugs								●			
Inspect valve clearance	Inspect every 105,000 miles (168,000 km), otherwise adjust only if noisy										
Replace manual transmission fluid	Every 120,000 miles (192,000 km) or every 6 years, whichever comes first										
Replace automatic transmission (CVT) fluid	Every 30,000 miles (48,000 km) or every 2 years, whichever comes first										
Inspect idle speed								●			
Replace engine coolant	At 120,000 miles (192,000 km) or 10 years, then every 60,000 miles (96,000 km) or 5 years										
Replace brake fluid	Every 3 years (independent of mileage)										

[#]: See information on maintenance and emissions warranty, last column, page 128.

Service the items listed at the indicated distance (or time, if given).											
	miles x 1,000	15	30	45	60	75	90	105	120	135	150
	km x 1,000	24	48	72	96	120	144	168	192	216	240
Check engine oil and coolant	Check oil and coolant at each fuel stop										
Check tires	Check inflation and condition once a month										
Replace engine oil and oil filter	Every 3,750 miles (6,000 km) or every 6 months, whichever comes first										
Rotate tires (follow pattern on page 159)	Every 7,500 miles (12,000 km)										
Check front and rear brake wear Inspect the following items: Tie-rod ends, steering gearbox, and boots Suspension components Driveshaft boots	Every 7,500 miles (12,000 km) or every 6 months, whichever comes first										
Check parking brake adjustment Lubricate all hinges, locks, and latches Inspect the following items: Brake hoses and lines (including ABS) All fluid levels and condition of fluids Exhaust system# Fuel lines and connections# Lights and controls/vehicle underbody	Every 15,000 miles (24,000 km) or every 1 year, whichever comes first										
Inspect drive belts Replace dust and pollen filter*	Every 30,000 miles (48,000 km) or every 2 years, whichever comes first										
Replace air cleaner element	Every 15,000 miles (24,000 km) (Use normal schedule except in dusty conditions)										
Replace spark plugs								●			
Inspect valve clearance	Inspect every 105,000 miles (168,000 km), otherwise adjust only if noisy										
Replace manual transmission fluid	Every 60,000 miles (96,000 km) or every 3 years, whichever comes first										
Replace automatic transmission (CVT) fluid	Every 30,000 miles (48,000 km) or every 2 years, whichever comes first										
Inspect idle speed								●			
Replace engine coolant	At 120,000 miles (192,000 km) or 10 years, then every 60,000 miles (96,000 km) or 5 years										
Replace brake fluid	Every 3 years (independent of mileage)										

: See information on maintenance and emissions warranty, last column, page 128 .

* : See dust and pollen filter on page 150 for replacement information under special driving conditions.

Maintenance Record *(for Normal and Severe Schedules)*

You or the servicing dealer can record all completed maintenance here, whether you follow the schedule for normal conditions (page 129) or severe conditions (page 130). Keep the receipts for all work done on your vehicle.

3,750 mi 6,000 km	Signature or dealer stamp	mi/km
		Date
7,500 mi 12,000 km		mi/km
		Date
11,250 mi 18,000 km		mi/km
		Date
15,000 mi 24,000 km		mi/km
		Date
18,750 mi 30,000 km		mi/km
		Date
22,500 mi 36,000 km		mi/km
		Date
26,250 mi 42,000 km		mi/km
		Date
30,000 mi 48,000 km		mi/km
		Date

33,750 mi 54,000 km	Signature or dealer stamp	mi/km
		Date
37,500 mi 60,000 km		mi/km
		Date
41,250 mi 66,000 km		mi/km
		Date
45,000 mi 72,000 km		mi/km
		Date
48,750 mi 78,000 km		mi/km
		Date
52,500 mi 84,000 km		mi/km
		Date
56,250 mi 90,000 km		mi/km
		Date
60,000 mi 96,000 km		mi/km
		Date

CONTINUED

Maintenance Record *(for Normal and Severe Schedules)*

63,750 mi 102,000 km	Signature or dealer stamp	mi/km
		Date
67,500 mi 108,000 km		mi/km
		Date
71,250 mi 114,000 km		mi/km
		Date
75,000 mi 120,000 km		mi/km
		Date
78,750 mi 126,000 km		mi/km
		Date
82,500 mi 132,000 km		mi/km
		Date
86,250 mi 138,000 km		mi/km
		Date
90,000 mi 144,000 km		mi/km
		Date

93,750 mi 150,000 km	Signature or dealer stamp	mi/km
		Date
97,500 mi 156,000 km		mi/km
		Date
101,250 mi 162,000 km		mi/km
		Date
105,000 mi 168,000 km		mi/km
		Date
108,750 mi 174,000 km		mi/km
		Date
112,500 mi 180,000 km		mi/km
		Date
116,250 mi 186,000 km		mi/km
		Date
120,000 mi 192,000 km		mi/km
		Date

Maintenance Record *(for Normal and Severe Schedules)*

123,750 mi 198,000 km	Signature or dealer stamp	mi/km
		Date
127,500 mi 204,000 km		mi/km
		Date
131,250 mi 210,000 km		mi/km
		Date
135,000 mi 216,000 km		mi/km
		Date
138,750 mi 222,000 km		mi/km
		Date
142,500 mi 228,000 km		mi/km
		Date
146,250 mi 234,000 km		mi/km
		Date
150,000 mi 240,000 km		mi/km
		Date

Fluid Locations

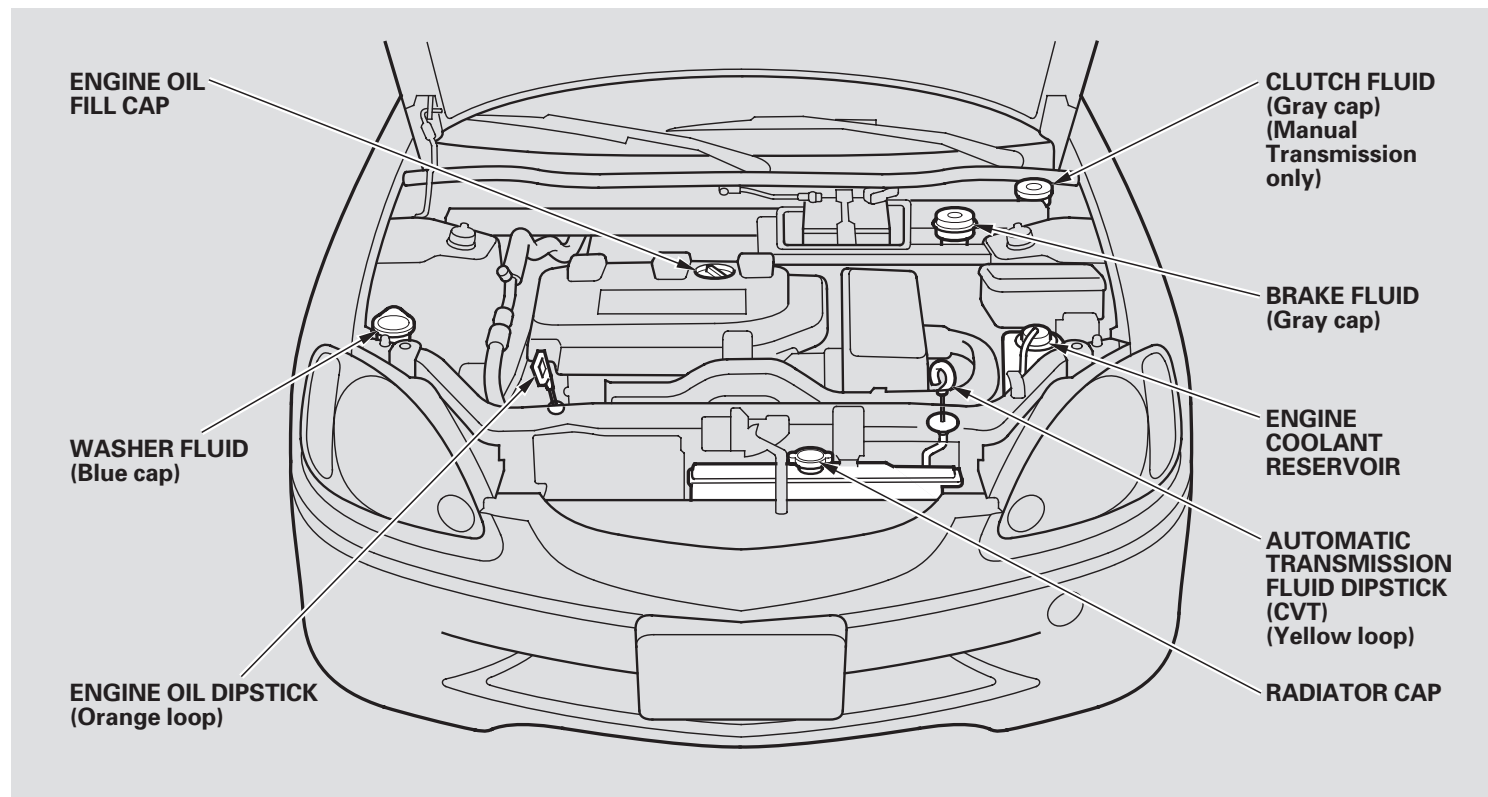

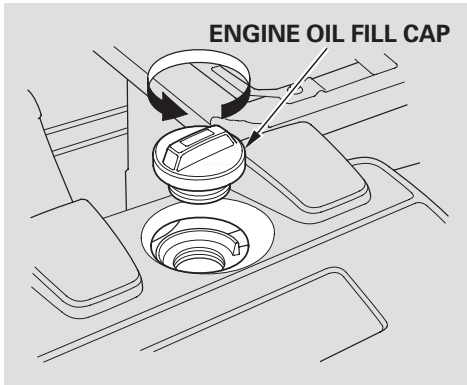

Unscrew and remove the engine oil fill cap on top of the valve cover. Pour in the oil slowly and carefully so you do not spill any. Clean up any spills immediately. Spilled oil could damage components in the engine compartment.

Install the engine oil fill cap, and tighten it securely. Wait a few minutes, and recheck the oil level. Do not fill above the upper mark; you could damage the engine.

Recommended Engine Oil

Oil is a major contributor to your engine's performance and longevity. Always use a premium-grade detergent oil displaying the API Certification Seal. This seal indicates the oil is energy conserving and that it meets the American Petroleum Institute's latest requirements. It is highly recommended that you use Honda Motor Oil in your vehicle for as long as you own it.

Make sure the API Certification Seal says "For Gasoline Engines".



CONTINUED

Adding Engine Oil, Changing the Oil and Filter

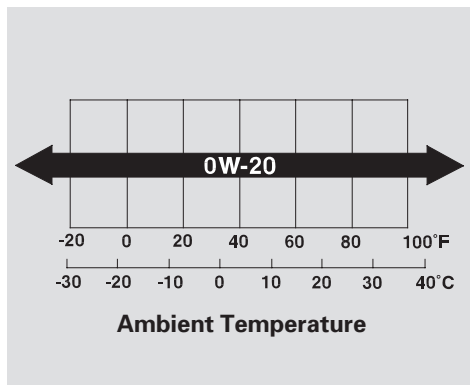

The oil viscosity or weight is provided on the container's label. A very low-viscosity, fuel-efficient 0W-20 oil is the preferred engine lubricant for your Insight. This special oil is formulated to help your engine use less fuel. It is available at your Honda dealer. A 5W-20 oil may be used if 0W-20 is not available.

Synthetic Oil

You may use a synthetic motor oil if it meets the same requirements given for a conventional motor oil: it displays the API Certification Seal, and it is the proper weight. You must follow the oil and filter change intervals given on the maintenance schedule.

Engine Oil Additives

Your vehicle does not require any oil additives. Additives may adversely affect your engine's or transmission's performance and durability.

Changing the Oil and Filter

Always change the oil and filter according to the recommendations in the maintenance schedule. The oil and filter collect contaminants that can damage your engine if they are not removed regularly.

Changing the oil and filter requires special tools and access from underneath the vehicle. The vehicle should be raised on a service station-type hydraulic lift for this service. Unless you have the knowledge and proper equipment, you should have this maintenance done by a skilled mechanic.

1. Run the engine until it reaches normal operating temperature, then shut it off.

Changing the Oil and Filter

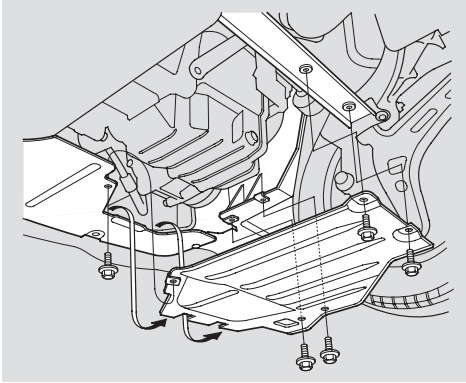

2. Open the hood and remove the engine oil fill cap. Remove the black cover under the engine.

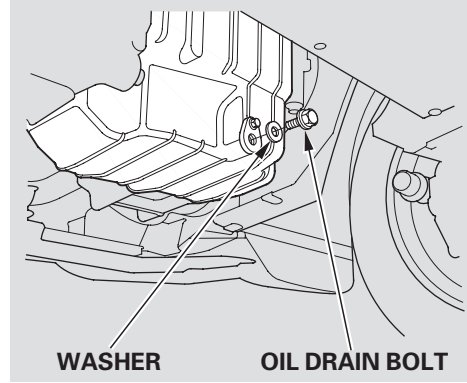

3. Remove the oil drain bolt and washer from the bottom of the engine. Drain the oil into an appropriate container.

Do not loosen the smaller bolt located above the drain bolt.

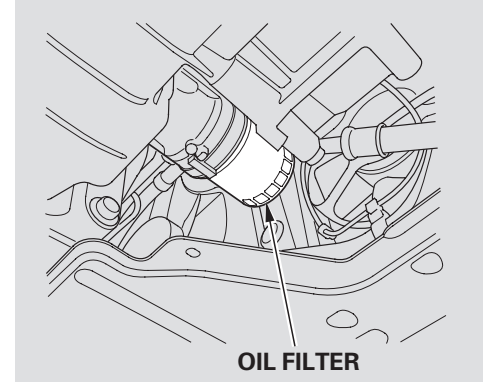

4. Remove the oil filter, and let the remaining oil drain. A special wrench (available from your dealer) is required.
5. Install a new oil filter according to the instructions that come with it. Make sure to clean off any dirt and dust on the connecting surface of a new oil filter.

CONTINUED

Changing the Oil and Filter

6. Put a new washer on the drain bolt, then reinstall the drain bolt. Tighten the drain bolt to:
29 lbf·ft (39 N·m , 4.0 kgf·m)

7. Refill the engine with the recommended oil.

Engine oil change capacity
(including filter):
2.6 US qt (2.5 ℓ)

8. Replace the engine oil fill cap. Start the engine. The oil pressure indicator should go out within 5 seconds. If it does not, turn off the engine, and check your work.

9. Let the engine run for several minutes, then check the drain bolt and oil filter for leaks.

10. Turn off the engine and let it sit for several minutes, then check the oil level on the dipstick. If necessary, add more oil.

11. Install the black cover under the engine.

NOTICE

Improper disposal of engine oil can be harmful to the environment. If you change your own oil, please dispose of the used oil properly. Put it in a sealed container, and take it to a recycling center. Do not discard it in a trash bin or dump it on the ground.

RESERVE TANK

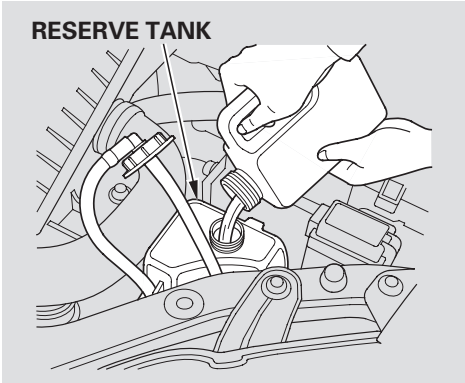

If the coolant level in the reserve tank is at or below the MIN line, add coolant to bring it up to between the MIN and MAX lines. Inspect the cooling system for leaks.

Always use Honda All Season Antifreeze/Coolant Type 2. This coolant is pre-mixed with 50 percent antifreeze and 50 percent water. Never add straight antifreeze or plain water.

If Honda antifreeze/coolant is not available, you may use another major-brand non-silicate coolant as a temporary replacement. Make sure it is a high-quality coolant recommended for aluminum engines. Continued use of any non-Honda coolant can result in corrosion, causing the cooling system to malfunction or fail. Have the cooling system flushed and refilled with Honda antifreeze/coolant as soon as possible.

If the reserve tank is completely empty, you should also check the coolant level in the radiator.

⚠ WARNING

Removing the radiator cap while the engine is hot can cause the coolant to spray out, seriously scalding you.

Always let the engine and radiator cool down before removing the radiator cap.

CONTINUED

Engine Coolant

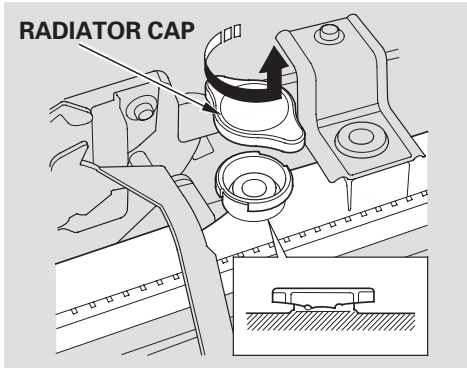

1. When the radiator and engine are cool, relieve any pressure in the cooling system by turning the radiator cap counterclockwise, without pressing down.
2. Remove the radiator cap by pushing down and turning counterclockwise.

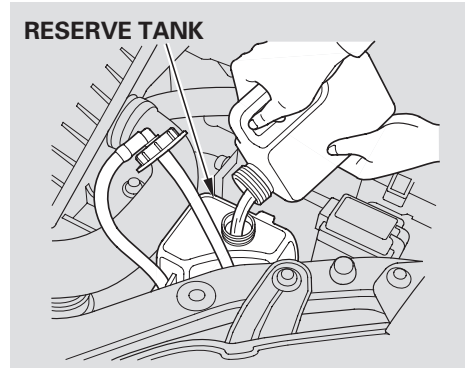

3. The coolant level should be up to the base of the filler neck. Add coolant if it is low.

Pour the coolant slowly and carefully so you do not spill any. Clean up any spills immediately; it could damage components in the engine compartment.

4. Put the radiator cap back on, and tighten it fully.
5. Pour coolant into the reserve tank. Fill it to halfway between the MAX and MIN marks. Put the cap back on the reserve tank.

Do not add any rust inhibitors or other additives to your vehicle's cooling system. They may not be compatible with the coolant or engine components.

Check the fluid level in the windshield washer reservoir at least monthly during normal use. This reservoir supplies the windshield and rear window washers.

Check the reservoir's fluid level by removing the cap and looking at the level gauge attached to the cap.

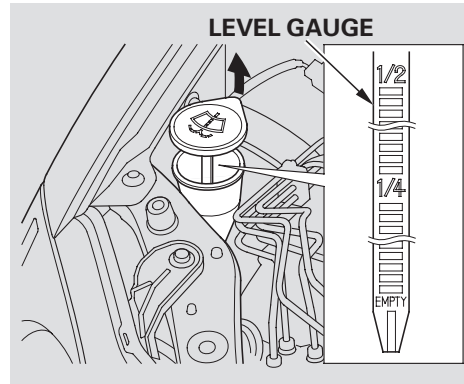

Fill the reservoir with a good-quality windshield washer fluid. This increases the cleaning capability and prevents freezing in cold weather.

When you refill the reservoir, clean the edges of the windshield wiper blades with windshield washer fluid on a clean cloth. This will help to condition them.

NOTICE

Do not use engine antifreeze or a vinegar/water solution in the windshield washer reservoir. Antifreeze can damage your vehicle's paint, while a vinegar/water solution can damage the windshield washer pump. Use only commercially-available windshield washer fluid.

Transmission Fluid

Automatic Transmission (CVT)

U.S. model

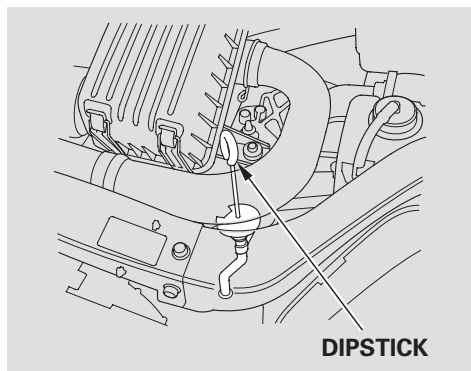

1. Park the vehicle on level ground. With the A/C off, let the engine run until the radiator cooling fan cycles on and off twice. Then turn off the engine.

NOTE: For accurate results, wait at least 60 seconds, and no more than 90 seconds, after turning off the engine to check the fluid level.

2. Remove the dipstick (yellow loop) from the transmission, and wipe it with a clean cloth.

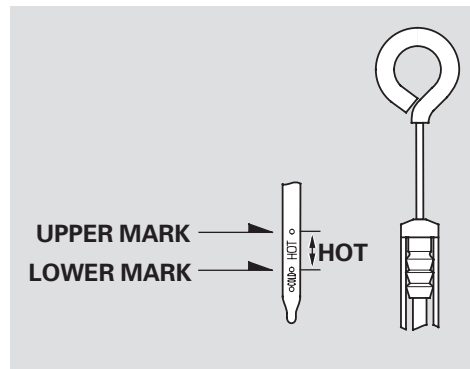

3. Insert the dipstick all the way back into the transmission securely as shown in the illustration.
4. Remove the dipstick and check the fluid level. It should be between the upper and lower marks within the HOT range.

5. If the level is below the lower mark, add fluid into the filler hole to bring it to the upper mark.

Pour the fluid slowly and carefully so you do not spill any. Clean up any spills immediately; it could damage components in the engine compartment.

Always use Honda ATF-Z1 (Automatic Transmission Fluid). If it's not available, you may use a DEXRON® III automatic transmission fluid as a temporary replacement. However, continued use can affect the shift quality. Have the transmission flushed and refilled with Honda ATF-Z1 as soon as it is convenient.

To thoroughly flush the transmission, the technician should drain and refill it with Honda ATF-Z1, then drive the vehicle for a short distance. Do this three times. Then drain and refill the transmission a final time.

6. Insert the dipstick all the way back into the transmission securely as shown in the illustration. If you added fluid, return to step 1 to recheck the fluid level.

The transmission should be drained and refilled with new fluid according to the time and distance recommendations in the maintenance schedule.

If you are not sure how to add fluid, contact your dealer.

Manual Transmission

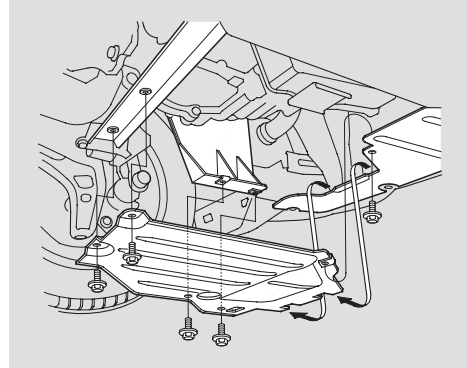

Check the fluid level with the transmission at normal operating temperature and the vehicle sitting on the level ground. Remove the black cover under the engine.

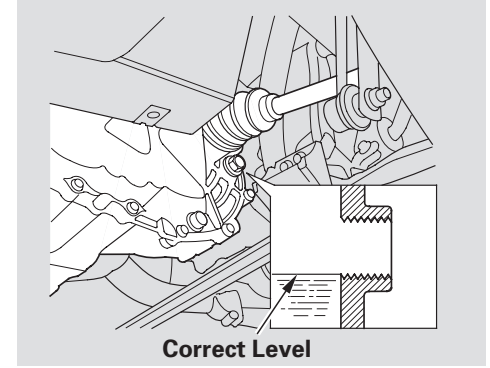

Remove the transmission filler bolt, and carefully feel inside the bolt hole with your finger. The fluid level should be up to the edge of the bolt hole. If it is not, add Honda Manual Transmission Fluid (MTF) until it starts to run out of the hole. Reinstall the filler bolt and tighten it securely.

CONTINUED

Transmission Fluid, Brake and Clutch Fluid

If Honda MTF is not available, you may use an SAE 10W-30 or 10W-40 viscosity motor oil with the API Certification seal that says “FOR GASOLINE ENGINES” as a temporary replacement. However, motor oil does not contain the proper additives, and continued use can cause stiffer shifting. Replace as soon as it is convenient.

The transmission should be drained and refilled with new fluid according to the time and distance recommendations in the maintenance schedule.

If you are not sure how to check and add fluid, contact your dealer.

Brake and Clutch Fluid

Check the fluid level in the reservoirs monthly. There are up to two reservoirs, depending on the model. They are:

- Brake fluid reservoir (all models)
- Clutch fluid reservoir (manual transmission only)

Replace the brake fluid according to the recommendation in the maintenance schedule.

Always use Honda Heavy Duty Brake Fluid DOT 3. If it is not available, you should use only DOT 3 or DOT 4 fluid, from a sealed container, as a temporary replacement.

Using any non-Honda brake fluid can cause corrosion and decrease the life of the system. Have the brake system flushed and refilled with Honda Heavy Duty Brake Fluid DOT 3 as soon as possible.

Brake fluid marked DOT 5 is not compatible with your vehicle's braking system and can cause extensive damage.

Brake System

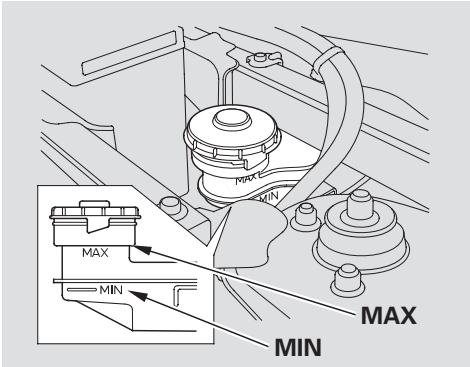

The fluid level should be between the MIN and MAX marks on the side of the reservoir. If the level is at or below the MIN mark, your brake system needs attention. Have the brake system inspected for leaks or worn brake pads.

Clutch System

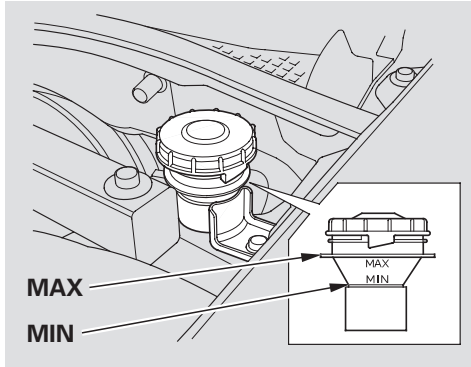

The fluid level should be between the MIN and MAX marks on the side of the reservoir. If it is not, add brake fluid to bring it up to that level. Use the same fluid specified for the brake system.

A low fluid level can indicate a leak in the clutch system. Have this system inspected as soon as possible.

Lights

Headlight Aiming

The headlights were properly aimed when your vehicle was new. If you regularly carry heavy items in the cargo area, readjustment may be required. Adjustments should be performed by your dealer or other qualified mechanic.

NOTICE

Halogen headlight bulbs get very hot when lit. Oil, perspiration, or a scratch on the glass can cause the bulb to overheat and shatter.

Replacing a Headlight Bulb

Your vehicle has halogen headlight bulbs. When replacing a bulb, handle it by its steel base and protect the glass from contact with your skin or hard objects. If you touch the glass, clean it with denatured alcohol and a clean cloth.

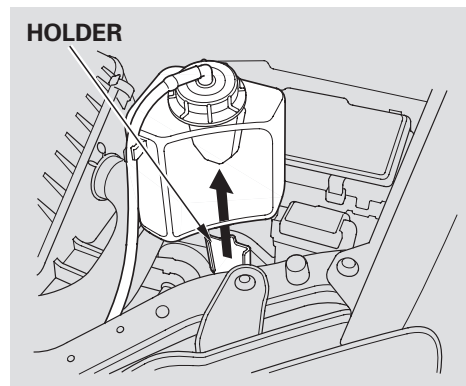

1. Open the hood.

To change the headlight bulb on the driver's side, remove the engine coolant reservoir tank by pulling it out of its holder.

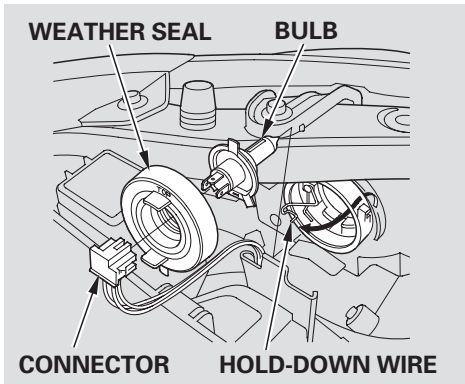

2. Remove the electrical connector from the bulb by squeezing the connector on both sides to unlock the tab. Pull the connector straight off.
3. Remove the rubber weather seal by pulling on the tab.

4. Unclip the end of the hold-down wire from its slot. Pivot it out of the way, and remove the bulb.
5. Insert the new bulb into the hole, making sure the tabs are in their slots. Pivot the hold-down wire back in place, and clip the end into the slot.
6. Install the rubber seal over the back of the headlight assembly. Make sure it is right side up; it is marked "TOP".
7. Push the electrical connector onto the tabs of the new bulb. Make sure it locks in place. Turn on the headlights to test the new bulb.
8. (Driver's side)
Reinstall the engine coolant reserve tank.

Replacing a Front Parking Light Bulb

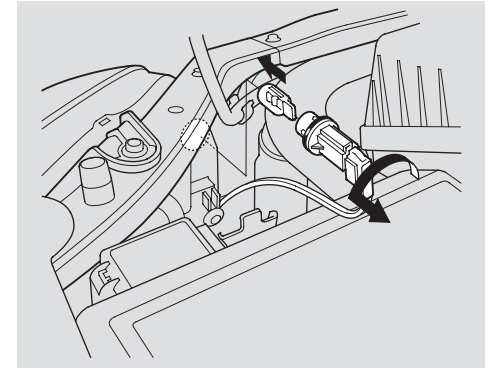

1. Remove the socket from the headlight assembly by turning it one-quarter turn counterclockwise.
2. Pull the bulb straight out of its socket.
3. Install the new bulb into the socket.

CONTINUED

Lights

4. Install the socket back into the headlight assembly. Turn it clockwise to lock it in place.
5. Turn on the lights to make sure the new bulb is working.

Replacing the Front Side Marker/ Turn Signal Light Bulb

1. To change the bulb on the driver's side, start the engine, turn the steering wheel all the way to the right, then turn off the engine. To change the bulb on the passenger's side, turn the steering wheel to the left.

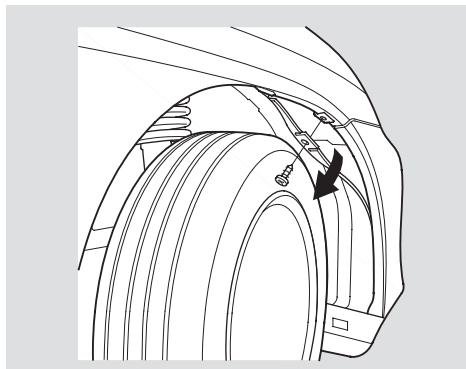

2. Use a Phillips-head screwdriver to remove the screw from the top of the fender.

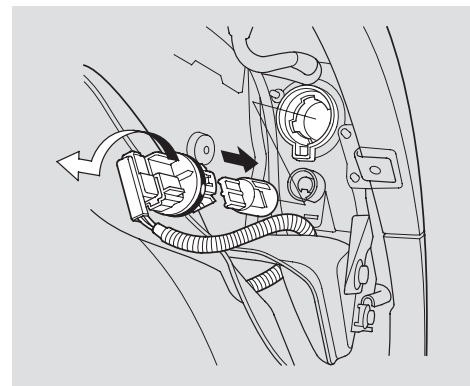

3. Pull the inner fender cover back.
4. Remove the socket from the headlight assembly by turning it one-quarter turn counterclockwise.
5. Pull the bulb straight out of its socket. Push the new bulb straight into the socket until it bottoms.

6. Install the socket back into the headlight assembly. Turn it clockwise to lock it in place.
7. Turn on the lights to make sure the new bulb is working.
8. Put the inner fender cover in place. Tighten the screw securely.

Replacing Rear Bulbs

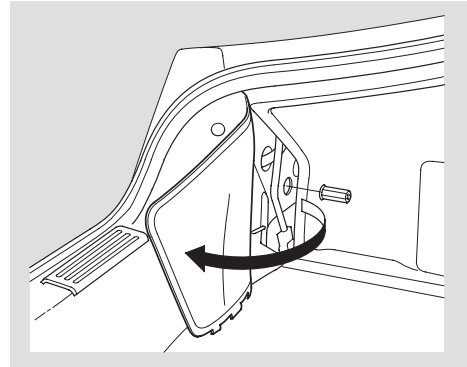

1. Open the hatch.
2. Pull the cover back.
3. Loosen the nut holding the rear light assembly.

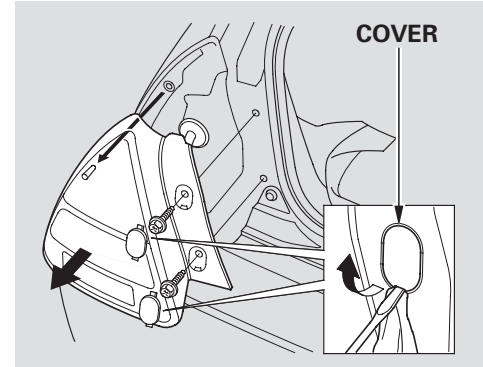

4. Remove the two covers. Remove the two screws holding the rear light assembly. Remove the light assembly.

CONTINUED

Lights

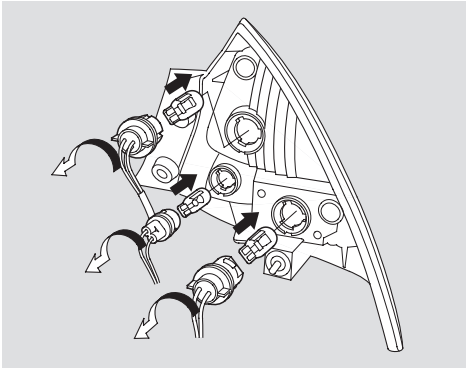

5. Determine which bulb, brake/taillight, back-up light, side marker light or turn signal is burned out. Remove the socket for that bulb by turning counterclockwise.
6. Pull the bulb straight out of its socket. Push the new bulb straight into the socket until it bottoms.

7. Reinstall the socket into the light assembly by turning it clockwise until it locks.
8. Turn on the lights to make sure the new bulb is working.
9. Reinstall the light assembly and tighten the two screws and nut.
10. Reinstall the two covers in the rear light assembly.
11. Put the cover in place in the cargo area.

Seat Belts

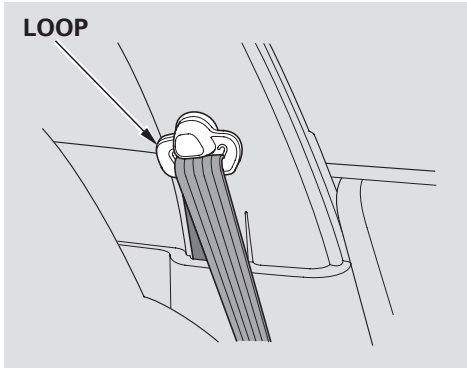

If your seat belts get dirty, use a soft brush with a mixture of mild soap and warm water to clean them. Do not use bleach, dye, or cleaning solvents. Let the belts air-dry before you use the vehicle.

Dirt build-up in the loops of the seat belt anchors can cause the belts to retract slowly. Wipe the insides of the loops with a clean cloth dampened in mild soap and warm water or isopropyl alcohol.

Floor Mats

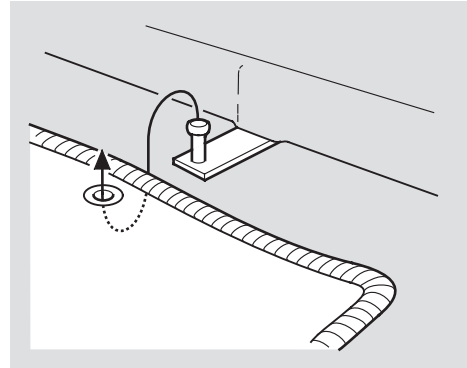

On models equipped

The driver's floor mat that came with your vehicle hooks over the floor mat anchor. This keeps the floor mat from sliding forward and possibly interfering with the pedals.

If you remove these floor mats, make sure to re-anchor them when you put them back in your vehicle.

If you use a non-Honda floor mat, make sure it fits properly and that it can be used with the floor mat anchor. Do not put additional floor mats on top of the anchored mat.

Dust and Pollen Filter, Roof Antenna

Dust and Pollen Filter

The dust and pollen filter removes pollen and dust from the outside air the climate control system brings into the interior. It should be replaced according to the time and distance recommendations in the maintenance schedule.

This filter should be replaced every 30,000 miles (48,000 km) under normal conditions. It should be replaced every 15,000 miles (24,000 km) if you drive primarily in urban areas that have high concentrations of soot in the air from industry and diesel-powered vehicles. Replace it more often if airflow from the climate control system becomes less than usual. Have the dust and pollen filter replaced by your dealer.

Roof Antenna

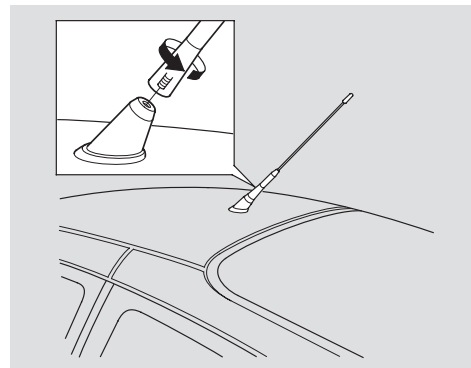

Before using an automatic car wash, remove the radio antenna so it does not get damaged. Remove the antenna by unscrewing it. When you reinstall the antenna, tighten it securely.

Rear Wheel Skirt

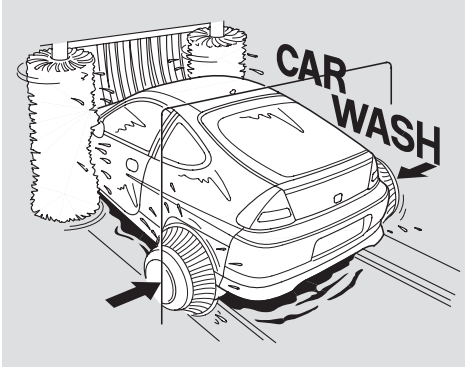

If an automatic car wash has tire cleaning brushes, remove the skirts covering the rear wheels so they will not be damaged. See page [168](#) for how to remove and install the skirts.

NOTICE

Although almost all exterior panels on your Honda are made of hardened aluminum, they may dent more easily than steel under some conditions. Exercise care when leaning on or over any part of the body.

Wiper Blades

Check the condition of the wiper blades at least every six months. Replace them if you find signs of cracking in the rubber, and areas that are getting hard, or if they leave streaks and unwiped areas when used.

CONTINUED

Wiper Blades

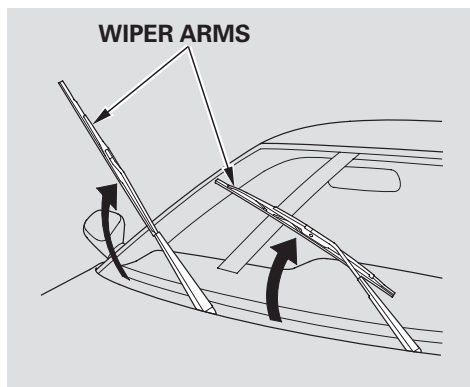

To replace a front wiper blade:

1. Raise the wiper arm off the windshield.

NOTICE

Do not open the hood when the wiper arms are raised, or you will damage the hood and the wiper arms.

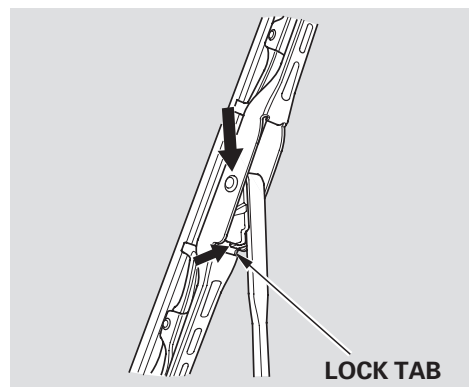

2. Disconnect the blade assembly from the wiper arm by pushing in the lock tab. Hold the lock tab in while you push the blade assembly toward the base of the arm.

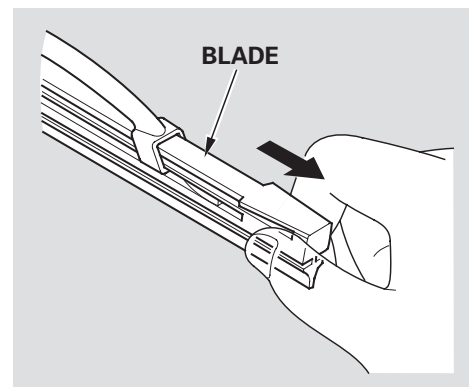

3. Remove the blade from its holder by grasping the tabbed end of the blade. Pull firmly until the tabs come out of the holder.

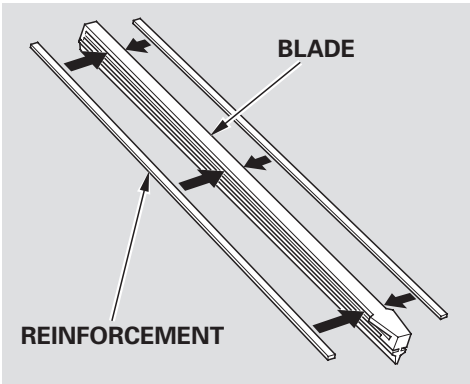

4. Examine the new wiper blades. If they have no plastic or metal reinforcement along the back edge, remove the metal reinforcement strips from the old wiper blade, and install them in the slots along the edge of the new blade.

5. Slide the new wiper blade into the holder until the tabs lock.
6. Slide the wiper blade assembly onto the wiper arm. Make sure it locks in place.
7. Lower the wiper arm down against the windshield.

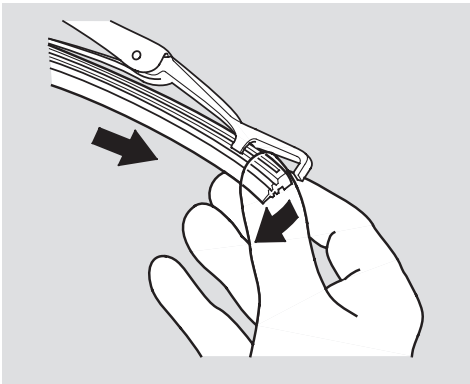

- To replace a rear wiper blade:
1. Raise the wiper arm off the windshield.
 2. Pull one end of the blade out from the holder.
 3. Slide the blade out of the holder.
 4. Slide the new blade into the holder. Make sure it is engaged in the slot along its full length.

CONTINUED

Wiper Blades, Tires

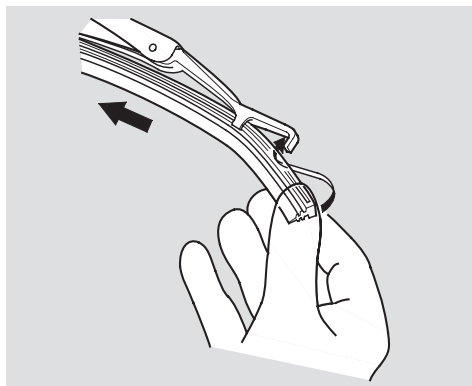

5. Insert both ends of the blade into the holder. Make sure they are secure.
6. Slide the wiper blade assembly onto the wiper arm. Make sure it locks in place.
7. Lower the wiper arm.

Tires

To safely operate your vehicle, your tires must be the proper type and size, in good condition with adequate tread, and correctly inflated.

The following pages give more detailed information on how to take care of your tires and what to do when they need to be replaced.

⚠ WARNING

Using tires that are excessively worn or improperly inflated can cause a crash in which you can be seriously hurt or killed.

Follow all instructions in this owner's manual regarding tire inflation and maintenance.

Inflation Guidelines

Keeping the tires properly inflated provides the best combination of handling, tread life, and riding comfort.

- Underinflated tires wear unevenly, adversely affect handling and fuel economy, and are more likely to fail from being overheated.
- Overinflated tires can make your vehicle ride more harshly, are more prone to damage from road hazards, and wear unevenly.

We recommend that you visually check your tires every day. If you think a tire might be low, check it immediately with a tire gauge.

Use a gauge to measure the air pressure at least once a month. Even tires that are in good condition may lose one to two psi (10 to 20 kPa, 0.1 to 0.2 kgf/cm²) per month. Remember to check the spare tire at the same time.

Check the pressure in the tires when they are cold. This means the vehicle has been parked for at least three hours, or driven less than 1 mile (1.6 km).

Add or release air, if needed, to match the recommended cold tire pressures on this page.

If you check the pressure when the tires are hot [driven for several miles (kilometers)], you will see readings 4 to 6 psi (30 to 40 kPa, 0.3 to 0.4 kgf/cm²) higher than the cold reading. This is normal; do not release air to match the cold pressure.

You should use your own tire pressure gauge whenever you check your tire pressures. This will make it easier for you to tell if a pressure loss is due to a tire problem and not due to a variation between gauges.

While tubeless tires have some ability to self-seal if they are punctured, you should look closely for punctures if a tire starts losing pressure.

Recommended Tire Pressures

The following chart shows the recommended cold tire pressures for most normal driving conditions.

Tire Size	Cold Tire Pressure for Normal Driving
P165/65R14 78S	Front: 38 psi (260 kPa , 2.6 kgf/cm ²) Rear: 35 psi (240 kPa , 2.4 kgf/cm ²)

The compact spare tire pressure is: 60 psi (420 kPa , 4.2 kgf/cm²)

For convenience, the recommended tire sizes and cold air pressures are on a label on the driver's doorjamb.

For additional technical information, see page [196](#).

Tires

Tire Inspection

Every time you check inflation, you should also examine the tires for damage, foreign objects, and wear.

You should look for:

- Bumps or bulges in the tread or side of the tire. Replace the tire if you find either of these conditions.
- Cuts, splits, or cracks in the side of the tire. Replace the tire if you can see fabric or cord.
- Excessive tread wear.

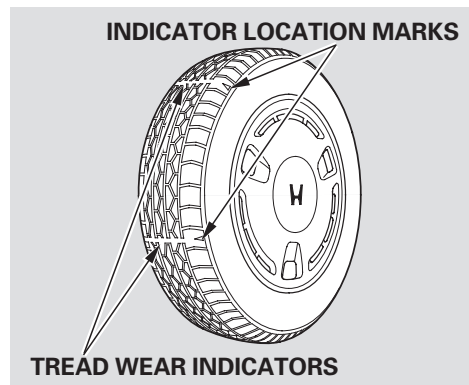

Your tires have wear indicators molded into the tread. When the tread wears down to that point, you will see a 1/2 inch (12.7 mm) wide band running across the tread. This shows there is less than 1/16 inch (1.6 mm) of tread left on the tire. A tire this worn gives very little traction on wet roads. You should replace the tire if you can see the tread wear indicator in three or more places around the tire.

Tire Maintenance

In addition to proper inflation, correct wheel alignment helps to decrease tire wear. If you find a tire is worn unevenly, have your dealer check the wheel alignment.

Have your dealer check the tires if you feel a consistent vibration while driving. A tire should always be rebalanced if it is removed from the wheel. When you have new tires installed, make sure they are balanced. This increases riding comfort and tire life. For best results, have the installer perform a dynamic balance.

NOTICE

Improper wheel weights can damage your vehicle's aluminum wheels. Use only Honda wheel weights for balancing.

Tire Rotation

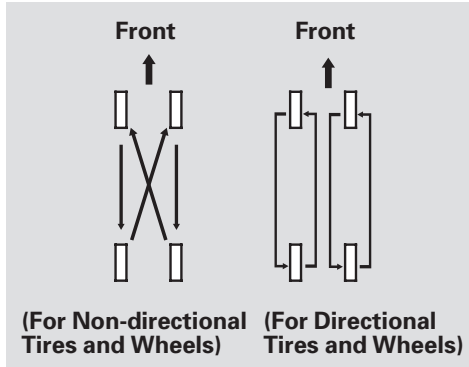

To help increase tire life and distribute wear more evenly, rotate the tires every 7,500 miles (12,000 km). Move the tires to the positions shown in the chart each time they are rotated. If you purchase directional tires, rotate only front-to-back.

Replacing Tires

Replace your tires with radial tires of the same size, load range, speed rating, and maximum cold tire pressure rating (as shown on the tire's sidewall). Mixing radial and bias-ply tires on your vehicle can reduce braking ability, traction, and steering accuracy. Using tires of a different size or construction can cause the ABS to work inconsistently.

The ABS works by comparing the speed of the wheels. When replacing tires, use the same size originally supplied with the vehicle. Tire size and construction can affect wheel speed and may cause the system to work inconsistently.

It is best to replace all four tires at the same time. If that is not possible or necessary, replace the two front tires or two rear tires as a pair. Replacing just one tire can seriously affect your vehicle's handling.

If you ever replace a wheel, make sure that the wheel's specifications match those of the original wheels. Replacement wheels are available at your dealer.

CONTINUED

Tires

WARNING

Installing improper tires on your vehicle can affect handling and stability. This can cause a crash in which you can be seriously hurt or killed.

Always use the size and type of tires recommended in this owner's manual.

Wheels and Tires Specifications

Wheels:
14 x 5 1/2 JJ

Tires:
P165/65R14 78S

See page [196](#) for DOT tire quality grading information, and page [198](#) for tire size information.

Winter Driving

Tires marked “M + S” or “All Season” on the sidewall have an all-weather tread design suitable for most winter driving conditions.

For the best performance in snowy or icy conditions, you should install snow tires or tire chains. They may be required by local laws under certain conditions.

Snow Tires

If you mount snow tires on your vehicle, make sure they are radial tires of the same size and load range as original tires. Mount snow tires on all four wheels. The traction provided by snow tires on dry roads may be lower than your original tires. Check with the tire dealer for maximum speed recommendations.

Tire Chains

Because your vehicle has limited tire clearance, mount only SAE Class “S” cable-type traction devices, with rubber chain tensioners on the front tires. Use traction devices only when required by driving conditions or local laws. Make sure they are the correct size for your tires. Metal link-type “chains” should not be used.

When installing cables, follow the manufacturer’s instructions, and mount them as tight as you can. Make sure they are not contacting the brake lines or suspension. Drive slowly with them installed. If you hear them coming into contact with the body or chassis, stop and investigate. Remove them as soon as you begin driving on cleared roads.

NOTICE

Traction devices that are the wrong size or improperly installed can damage your vehicle’s brake lines, suspension, body, and wheels. Stop driving if they are hitting any part of the vehicle.

Checking the Battery

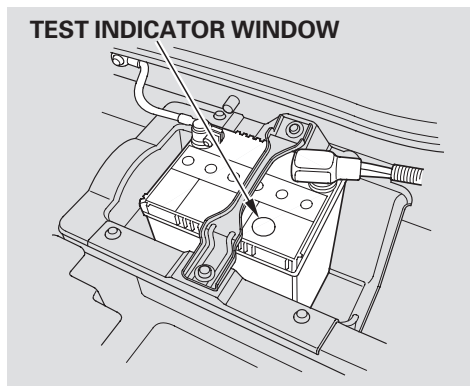

Check the condition of the battery monthly by looking at the test indicator window. The label on the battery explains the test indicator's colors.

Check the terminals for corrosion (a white or yellowish powder). To remove it, cover the terminals with a solution of baking soda and water. It will bubble up and turn brown. When this stops, wash it off with plain water. Dry off the battery with a cloth or paper towel. Coat the terminals with grease to help prevent future corrosion.

If additional battery maintenance is needed, see your dealer or a qualified technician.

WARNING: Battery posts, terminals, and related accessories contain lead and lead compounds. **Wash your hands after handling.**

If you need to connect the battery to a charger, disconnect both cables to prevent damaging your vehicle's electrical system. Always disconnect the negative (–) cable first, and reconnect it last.

WARNING

The battery gives off explosive hydrogen gas during normal operation.

A spark or flame can cause the battery to explode with enough force to kill or seriously hurt you.

Wear protective clothing and a face shield, or have a skilled mechanic do the battery maintenance.

If you need to park your vehicle for an extended period (more than one month), there are several things you should do to prepare it for storage. Proper preparation helps prevent deterioration and makes it easier to get your vehicle back on the road. If possible, store your vehicle indoors.

- Fill the fuel tank.
- Change the engine oil and filter.
- Wash and dry the exterior completely.
- Clean the interior. Make sure the carpeting, floor mats, etc., are completely dry.
- Leave the parking brake off. Put the transmission in Reverse (manual) or Park (CVT).
- Block the rear wheels.

- If the vehicle is to be stored for a longer period, it should be supported on jackstands so the tires are off the ground.
- Leave one window open slightly (if the vehicle is being stored indoors).
- Disconnect the 12 volt battery.
- Support the front and rear wiper blade arms with a folded towel or rag so they do not touch the windshield.
- To minimize sticking, apply a silicone spray lubricant to all door and hatch seals. Also, apply a vehicle body wax to the painted surfaces that mate with the door and hatch seals.

- Cover the vehicle with a “breathable” cover, one made from a porous material such as cotton. Non-porous materials, such as plastic sheeting, trap moisture, which can damage the paint.
- Reconnect the 12 volt battery and drive your vehicle every month for about 30 minutes. This will keep the IMA battery charged and in good condition.

If you store your vehicle for 1 year or longer, have your dealer perform the inspections called for in the 2 years/30,000 miles (48,000 km) maintenance schedule (Normal Conditions) as soon as you take it out of storage (see page 129). The replacements called for in the maintenance schedule are not needed unless the vehicle has actually reached that time or mileage.

This section covers the more common problems that motorists experience with their vehicles. It gives you information about how to safely evaluate the problem and what to do to correct it. If the problem has stranded you on the side of the road, you may be able to get going again. If not, you will also find instructions on getting your vehicle towed.

Compact Spare Tire.....	166
Changing a Flat Tire	167
If the Engine Won't Start.....	173
Nothing Happens or the Starter Motor Operates Very Slowly.....	173
Jump Starting	175
If the Engine Overheats	177
Low Oil Pressure Indicator	179
Charging System Indicator.....	180
Malfunction Indicator Lamp	180
Brake System Indicator	182
Emergency Towing	183
If Your Vehicle Gets Stuck.....	184
Fuses	185
Checking and Replacing Fuses	185
Fuse Locations	188

Compact Spare Tire

Use the compact spare tire as a temporary replacement only. Get your regular tire repaired or replaced, and put it back on your vehicle as soon as you can.

Check the compact spare tire inflation pressure every time you check the other tires. It should be inflated to:
60 psi (420 kPa , 4.2 kgf/cm²)

Follow these precautions:

- Never exceed 50 mph (80 km/h).
- This tire gives a harsher ride and less traction on some road surfaces. Use greater caution while driving.
- Do not mount snow chains on it.
- Do not use your compact spare tire on another vehicle unless it is the same make and model.

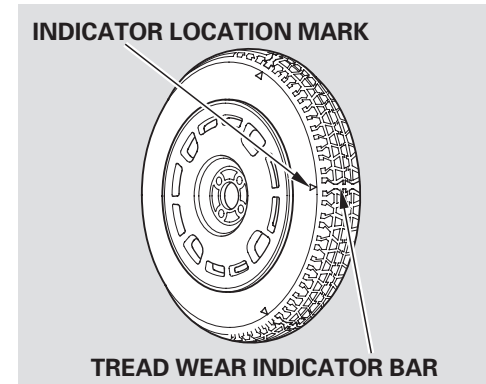

Replace the tire when you can see the tread wear indicator bars. The replacement should be the same size and design tire, mounted on the same wheel. The spare tire is not designed to be mounted on a regular wheel, and the spare wheel is not designed for mounting a regular tire.

Changing a Flat Tire

If you have a flat tire while driving, stop in a safe place to change it. Drive slowly along the shoulder until you get to an exit or an area that is far away from the traffic lanes.

⚠ WARNING

The vehicle can easily roll off the jack, seriously injuring anyone underneath.

Follow the directions for changing a tire exactly, and never get under the vehicle when it is supported only by the jack.

1. Park the vehicle on firm, level and non-slippery ground. Put the transmission in Reverse (5-speed manual) or Park (CVT). Apply the parking brake.
2. Turn on the hazard warning indicators, and turn the ignition switch to LOCK (0). Have your passenger get out of the vehicle while you change the tire.
3. Open the hatch. Raise the cargo area floor by lifting up on the back edge.

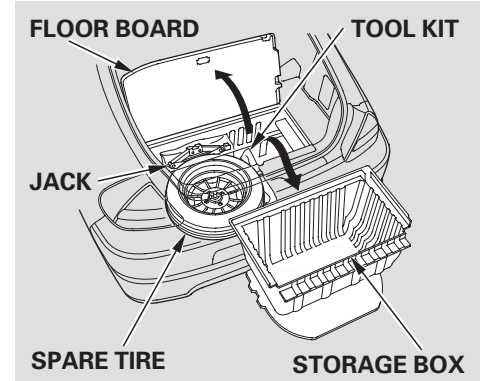

4. Remove the storage box from the cargo area well.
5. Take the tool kit from the spare tire well. Remove the jack (in the jack cover) from the inside of the spare tire.
6. Unscrew the wing bolt, and take the spare tire out of its well.

CONTINUED

Changing a Flat Tire

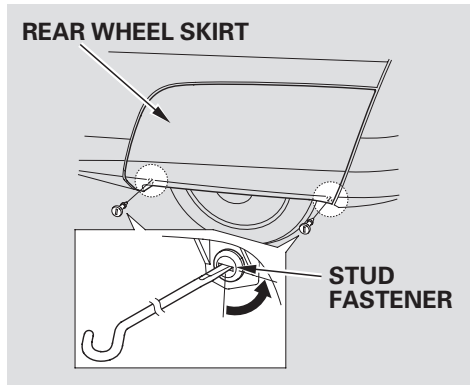

1. Rear tire only:
Use the end of the extension or a flat-tipped screwdriver to loosen the two stud fasteners holding the rear wheel skirt.

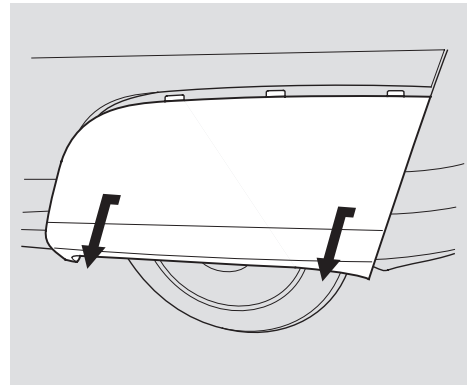

2. Pull the rear wheel skirt downward.

Do not catch your clothes or hands on the hooks on the rear fender when you replace the wheel.

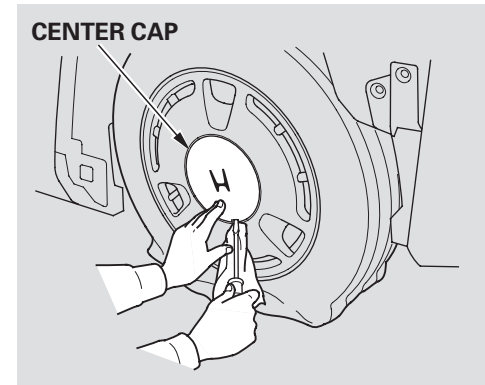

3. Remove the center cap from the wheel with the end of the extension or a flat-tipped screwdriver.
4. Loosen each wheel nut 1/2 turn with the wheel nut wrench.

Changing a Flat Tire

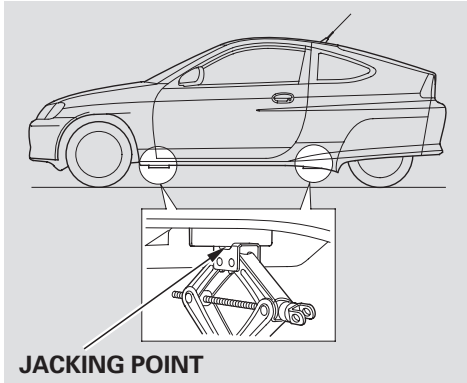

5. Place the jack under the jacking point nearest the tire you need to change. It is pointed to by an arrow molded into the underside of the body. Turn the end bracket clockwise until the top of the jack contacts the jacking point. Make sure the jacking point tab is resting in the jack notch.

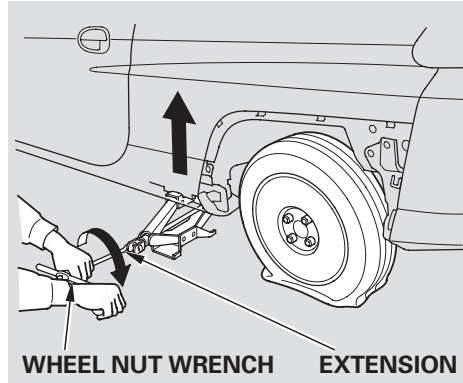

6. Use the extension and wheel wrench as shown to raise the vehicle until the flat tire is off the ground.

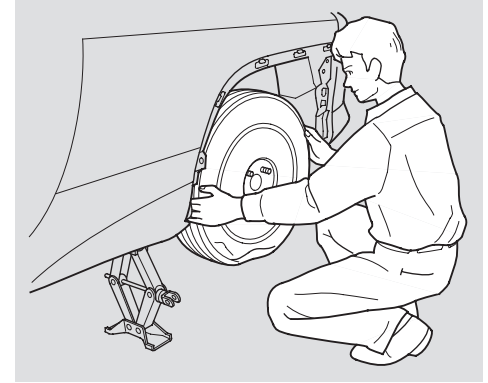

7. Remove the wheel nuts, then remove the flat tire. Handle the wheel nuts carefully; they may be hot from driving. Place the flat tire on the ground with the outside surface facing up.

CONTINUED

Changing a Flat Tire

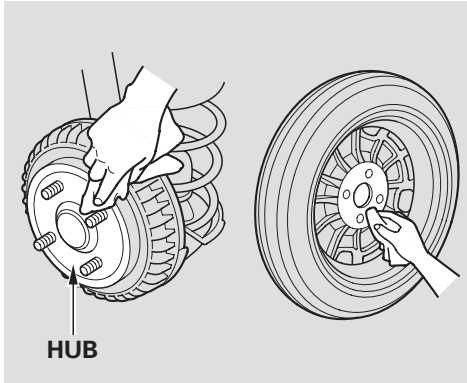

8. Before mounting the spare tire, wipe any dirt off the mounting surface of the wheel and hub with a clean cloth. Wipe the hub carefully; it may be hot from driving.

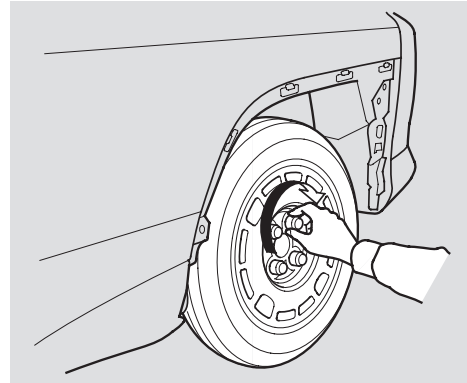

9. Put on the spare tire. Put the wheel nuts back on finger-tight, then tighten them in a crisscross pattern with the wheel nut wrench until the wheel is firmly against the hub. Do not try to tighten them fully.

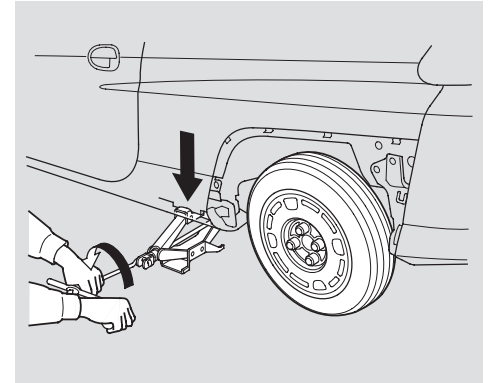

10. Lower the vehicle to the ground and remove the jack.

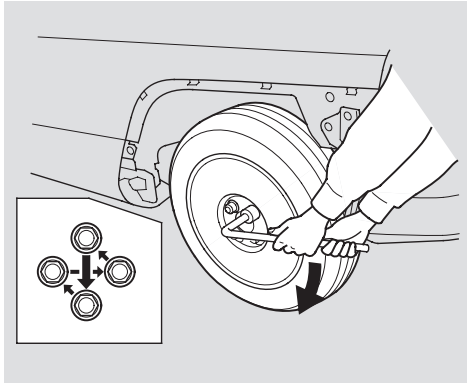

11. Tighten the wheel nuts securely in the same crisscross pattern. Have the wheel nut torque checked at the nearest automotive service facility.

Tighten the wheel nuts to:
80 lbf-ft (108 N·m , 11 kgf-m)

Do not catch your clothes or hands on the hooks on the rear fender when you replace the wheel.

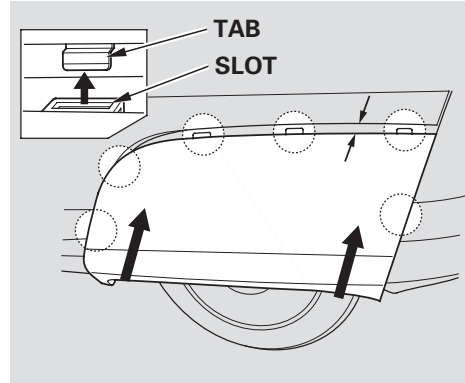

12. To install the rear wheel skirt, place the skirt against the body. Line up the slots on the skirt with the tabs in the body, then push the skirt upward.

Make sure the wheel skirt is installed correctly.

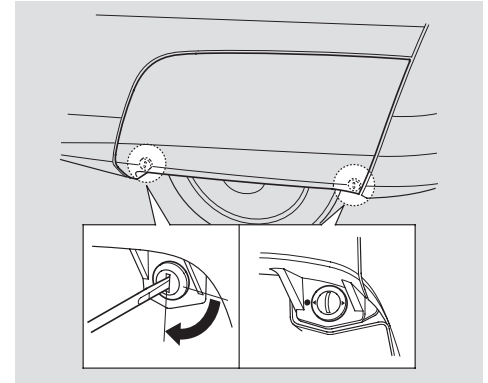

13. Tighten the two stud fasteners. Align the ▼ marks on the stud fastener with the ● marks on the wheel skirt.

It is not recommended to drive your vehicle without the wheel skirts. It will affect the fuel consumption.

CONTINUED

Changing a Flat Tire

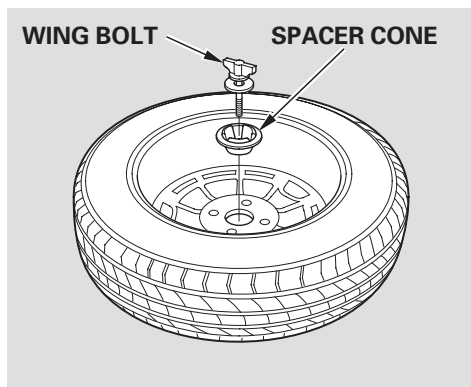

14. Place the flat tire face down in the spare tire well.
15. Remove the spacer cone from the wing bolt, turn it over, and put it back on the bolt.
16. Secure the flat tire by screwing the wing bolt back into its hole.

17. Store the jack and tool kit back in the spare tire well.

⚠ WARNING

Loose items can fly around the interior in a crash and could seriously injure the occupants.

Store the wheel, jack, and tools securely before driving.

18. Store the center cap in the spare tire well. Make sure it does not get scratched or damaged.
19. Install the storage box in the cargo area well.
20. Lower the cargo area floor, then close the hatch.

Diagnosing why the engine won't start falls into two areas, depending on what you hear when you turn the key to START (III):

- You hear nothing, or almost nothing. The engine's starter motor does not operate at all, or operates very slowly.
- You can hear the starter motor operating normally, or the starter motor sounds like it is spinning faster than normal, but the engine does not start up and run.

Nothing Happens or the Starter Motor Operates Very Slowly

When you turn the ignition switch to START (III), you do not hear the normal noise of the engine trying to start. You may hear a clicking sound or series of clicks, or nothing at all. Check these things:

- Check the transmission interlock. If you have a manual transmission, the clutch pedal must be pushed all the way to the floor or the starter will not operate. With an automatic transmission, it must be in Park or Neutral.
- Are you using a properly coded key? An improperly coded key will cause the immobilizer system indicator in the instrument panel to blink rapidly (see page 60).

- Turn the ignition switch to ON (II). Turn on the headlights, and check their brightness. If the headlights are very dim or do not come on at all, the battery is discharged. See **Jump Starting** on page 175 .
- Turn the ignition switch to START (III). If the headlights do not dim, check the condition of the fuses. If the fuses are OK, there is probably something wrong with the electrical circuit for the ignition switch or starter motor. You will need a qualified technician to determine the problem (see **Emergency Towing** on page 183).

CONTINUED

If the Engine Won't Start

If the headlights dim noticeably or go out when you try to start the engine, either the battery is discharged or the connections are corroded. Check the condition of the battery and terminal connections (see page [162](#)). You can then try jump starting the vehicle from a booster battery (see page [175](#)).

The Starter Operates Normally

In this case, the starter motor's speed sounds normal, or even faster than normal, when you turn the ignition switch to START (III), but the engine does not run.

- Are you using the proper starting procedure? Refer to **Starting the Engine** on page [109](#) .
- Do you have fuel? Check the fuel gauge; the low fuel indicator may not be working.
- There may be an electrical problem, such as no power to the fuel pump. Check all the fuses (see page [185](#)).

If you find nothing wrong, you will need a qualified technician to find the problem. See **Emergency Towing** on page [183](#) .

Although this seems like a simple procedure, you should take several precautions.

⚠ WARNING

A battery can explode if you do not follow the correct procedure, seriously injuring anyone nearby.

Keep all sparks, open flames, and smoking materials away from the battery.

You cannot start your vehicle with an automatic transmission (CVT) by pushing or pulling it.

To jump start your vehicle:

1. Open the hood, and check the physical condition of the battery. In very cold weather, check the condition of the electrolyte. If it seems slushy or frozen, do not try jump starting until it thaws.

NOTICE

If a battery sits in extreme cold, the electrolyte inside can freeze. Attempting to jump start with a frozen battery can cause it to rupture.

2. Turn off all the electrical accessories: heater, A/C, climate control, stereo system, lights, etc. Put the transmission in Neutral or Park, and set the parking brake.
3. Connect one jumper cable to the positive (+) terminal on your battery. Connect the other end to the positive (+) terminal on the booster battery.

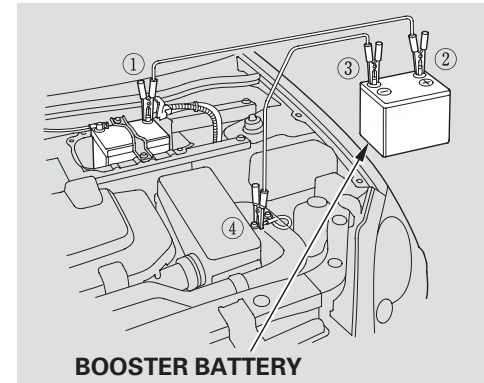

The numbers in the illustration show you the order to connect the jumper cables.

CONTINUED

Jump Starting

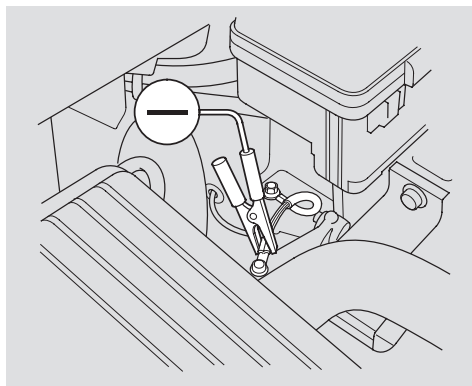

4. Connect the second jumper cable to the negative (-) terminal on the booster battery. Connect the other end to the grounding strap as shown. Do not connect this jumper cable to any other part of the engine.
5. If the booster battery is in another vehicle, have an assistant start that vehicle and run it at a fast idle.

6. Start the vehicle. If the starter motor still operates slowly, check that the jumper cables have good metal-to-metal contact.
7. Once the vehicle is running, disconnect the negative cable from your vehicle, then from the booster battery. Disconnect the positive cable from the vehicle, and then from the booster battery.

Keep the ends of the jumper cables away from each other and any metal on the vehicle until everything is disconnected. Otherwise, you may cause an electrical short.

The reading on your vehicle's temperature gauge should stay in the midrange. If it climbs to the red mark, you should determine the reason (hot day, driving up a steep hill, etc.).

If your vehicle overheats, you should take immediate action. The only indication may be the temperature gauge reading reaching the red mark. Or you may see steam or spray coming from under the hood.

NOTICE

Driving with the temperature gauge reading at the red mark can cause serious damage to your engine.

WARNING

Steam and spray from an overheated engine can seriously scald you.

Do not open the hood if steam is coming out.

1. Safely pull to the side of the road. Put the transmission in Neutral or Park, and set the parking brake. Turn off all accessories, and turn on the hazard warning lights.
2. If you see steam and/or spray coming from under the hood, turn off the engine. Wait until you see no more signs of steam or spray, then open the hood.
3. If you do not see steam or spray, leave the engine running and watch the temperature gauge. If the high heat is due to overloading, the engine should start to cool down almost immediately. If it does, wait until the temperature gauge reading comes down to the midpoint, then continue driving.
4. If the temperature gauge stays at the red mark, turn off the engine.
5. Look for any obvious coolant leaks, such as a split radiator hose. Everything is still extremely hot, so use caution. If you find a leak, it must be repaired before you continue driving (see **Emergency Towing** on page 183).

CONTINUED

If the Engine Overheats

6. If you do not find an obvious leak, check the coolant level in the radiator reserve tank. Add coolant if the level is below the MIN mark.
7. If there was no coolant in the reserve tank, you may need to add coolant to the radiator. Let the engine cool down until the reading reaches the middle of the temperature gauge, or lower, before checking the radiator.

WARNING

Removing the radiator cap while the engine is hot can cause the coolant to spray out, seriously scalding you.

Always let the engine and radiator cool down before removing the radiator cap.

8. Using gloves or a large heavy cloth, turn the radiator cap counterclockwise, without pushing down, to the first stop. After the pressure releases, push down on the cap, and turn it until it comes off.
9. Start the engine, and set the temperature control dial to maximum. Add coolant to the radiator up to the base of the filler neck. If you do not have the proper coolant mixture available, you can add plain water. Remember to have the cooling system drained and refilled with the proper mixture as soon as you can.
10. Put the radiator cap back on tightly. Run the engine, and watch the temperature gauge. If it goes back to the red mark, the engine needs repair (see **Emergency Towing** on page [183](#)).
11. If the temperature stays normal, check the coolant level in the radiator reserve tank. If it has gone down, add coolant to the MAX mark. Put the cap back on tightly.



This indicator should never come on when the engine is running. If it starts flashing or stays on, the oil pressure has dropped very low or lost pressure. Serious engine damage is possible and you should take immediate action.

NOTICE

Running the engine with low oil pressure can cause serious mechanical damage almost immediately. Turn off the engine as soon as you can safely get the vehicle stopped.

1. Safely pull off the road, and shut off the engine. Turn on the hazard warning indicators.
2. Let the vehicle sit for a minute. Open the hood, and check the oil level (see page [97](#)). An engine very low on oil can lose pressure during cornering and other driving maneuvers.
3. If necessary, add oil to bring the level back to the full mark on the dipstick (see page [135](#)).
4. Start the engine, and watch the oil pressure indicator. If it does not go out within 10 seconds, turn off the engine. There is a mechanical problem that needs to be repaired before you can continue driving (see **Emergency Towing** on page [183](#)).

The engine running generates the oil pressure. When the auto idle stop is activated, the engine is stopped, but the low oil pressure indicator does not come on.

Charging System Indicator, Malfunction Indicator Lamp

Charging System Indicator



If the charging system indicator comes on brightly when the engine is running, the battery is not being charged.

Immediately turn off all electrical accessories. Try not to use other electrically operated controls such as the power windows. Keep the engine running; starting the engine will discharge the battery rapidly.

Go to a service station or garage where you can get technical assistance.

Malfunction Indicator Lamp



If the indicator comes on while driving, it means one of the engine's emissions control systems may have a problem. Even though you may feel no difference in your vehicle's performance, it can reduce your fuel economy and cause increased emissions. Continued operation may cause serious damage.

If you have recently refueled your vehicle, the indicator could come on because of a loose or missing fuel fill cap. Tighten the cap until it clicks at least three times. Tightening the cap will not turn the indicator off immediately; it takes at least three days of normal driving.

If the indicator remains on, or the fuel cap was not loose or missing, have your vehicle checked by the dealer as soon as possible.

NOTICE

If you keep driving with the Malfunction Indicator Lamp on, you can damage your vehicle's emissions controls and the engine. Those repairs may not be covered by your vehicle's warranties.

This indicator may also come on along with the "D" indicator.

Readiness Codes

Your vehicle has certain “readiness codes” that are part of the on-board diagnostics for the emissions systems. In some states, part of the emissions testing is to make sure these codes are set. If they are not set, the test cannot be completed.

If your 12 volt vehicle’s battery has been disconnected or gone dead, these codes are erased. It takes at least three days of driving under various conditions to set the codes again.

To check if they are set, turn the ignition to ON (II), without starting the engine. The malfunction indicator lamp will come on for 20 seconds. If it then goes off, the readiness codes are set. If it blinks five times, the readiness codes are not set. If possible, do not take your vehicle for a state emissions test until the readiness codes are set. Refer to **State Emissions Testing** for more information (see page [202](#)).

Brake System Indicator

U.S.

BRAKE

Canada



The brake system indicator normally comes on when you turn the ignition switch to ON (II) and as a reminder to check the parking brake. It will stay lit if you do not fully release the parking brake.

If the brake system indicator comes on while driving, the brake fluid level is probably low. Press lightly on the brake pedal to see if it feels normal. If it does, check the brake fluid level the next time you stop at a service station (see page [145](#)).

If the fluid level is low, take your vehicle to a dealer, and have the brake system inspected for leaks or worn brake pads.

However, if the brake pedal does not feel normal, you should take immediate action. A problem in one part of the system's dual circuit design will still give you braking at two wheels. You will feel the brake pedal go down much farther before the vehicle begins to slow down, and you will have to press harder on the pedal.

Slow down by shifting to a lower gear, and pull to the side of the road when it is safe. Because of the long distance needed to stop, it is hazardous to drive the vehicle. You should have it towed and repaired as soon as possible (see **Emergency Towing** on page [183](#)).

If you must drive the vehicle a short distance in this condition, drive slowly and carefully.

If your vehicle needs to be towed, call a professional towing service or organization. Never tow your vehicle with just a rope or chain. It is very dangerous.

There are three popular types of professional towing equipment.

Flat-bed Equipment — The operator loads your vehicle on the back of a truck. **This is the best way to transport your vehicle.**

Wheel-lift Equipment — The tow truck uses two pivoting arms that go under the tires (front or rear) and lift them off the ground. The other two tires remain on the ground. **This is an acceptable way to tow your vehicle.**

Sling-type Equipment — The tow truck uses metal cables with hooks on the ends. These hooks go around parts of the frame or suspension and

the cables lift that end of the vehicle off the ground. Your vehicle's suspension and body can be seriously damaged. **This method of towing is unacceptable.**

If your vehicle cannot be transported by flat-bed, it should be towed by wheel-lift equipment with the front wheels off the ground. If, due to damage, your vehicle must be towed with the front wheels on the ground, do the following:

5-speed Manual Transmission:

- Release the parking brake.
- Shift the transmission to Neutral.

Automatic Transmission (CVT):

- Release the parking brake.
- Start the engine.
- Shift to D, then to N.
- Turn off the engine.

NOTICE

Improper towing preparation will damage the transmission. Follow the above procedure exactly. If you cannot shift the transmission or start the engine (CVT), your vehicle must be transported with the front wheels off the ground.

With the front wheels on the ground, it is best to tow the vehicle no farther than 50 miles (80 km), and keep the speed below 35 mph (55 km/h).

If your vehicle is equipped with a front spoiler, remove it before towing so it is not damaged.

NOTICE

Trying to lift or tow your vehicle by the bumpers will cause serious damage. The bumpers are not designed to support the vehicle's weight.

Emergency Towing

If Your Vehicle Gets Stuck

If your vehicle gets stuck in sand, mud, or snow, call a towing service to pull it out (see page 183).

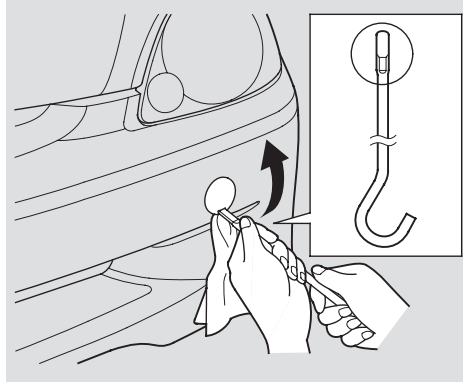

For very short distances, such as freeing the vehicle, you can use the detachable towing hook that mounts on the anchor in the front bumper.

To use the towing hook:

1. Remove the towing hook and wheel wrench from the tool box.

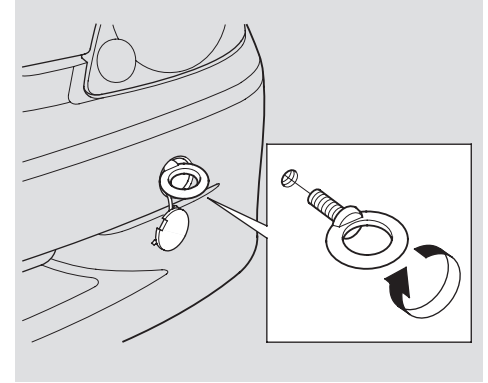

2. Remove the cover from the bumper with the end of the extension.
3. Screw the towing hook into the hole and tighten it securely by hand.

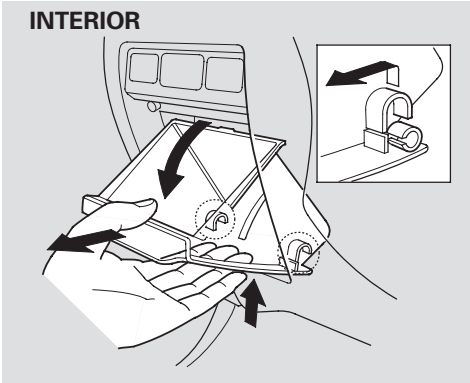

The interior fuse is underneath the dashboard on the driver's side. Remove the storage pocket by swinging the lid down, pushing up, and pulling it straight out of its hinges.

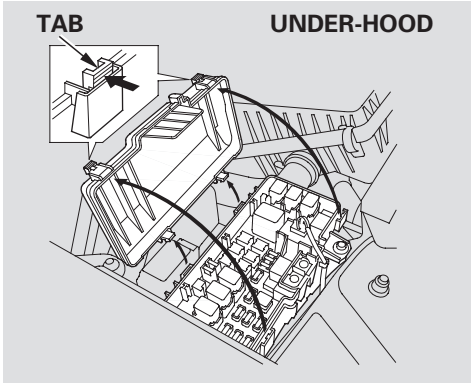

The under-hood fuse box is in the engine compartment. To open it, push the tabs as shown.

Checking and Replacing Fuses

If something electrical in your vehicle stops working, the first thing you should check for is a blown fuse. Determine from the chart on pages [188](#) and [189](#), or the diagram on the fuse box lid, which fuse or fuses control that device. Check those fuses first, but check all the fuses before deciding that a blown fuse is the cause. Replace any blown fuses, and check if the device works.

1. Turn the ignition switch to LOCK (0). Make sure the headlights and all other accessories are off.
2. Remove the cover from the fuse box.

CONTINUED

Fuses

FUSE

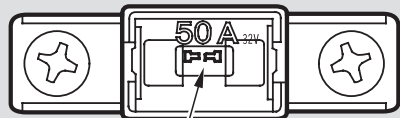

BLOWN

3. Check each of the large fuses in the under-hood fuse box by looking through the top at the wire inside. Removing these screws requires a Phillips-head screwdriver.

FUSE PULLER

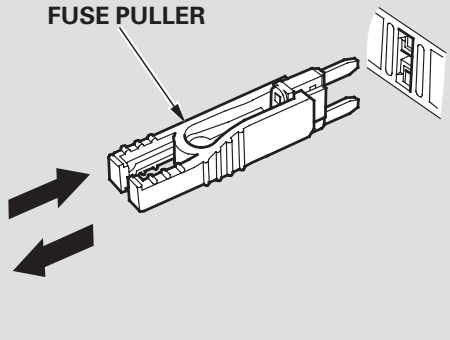

4. Check the smaller fuses in the under-hood fuse box and all the fuses in the interior fuse box by pulling out each one with the fuse puller provided in the under-hood fuse box.

BLOWN

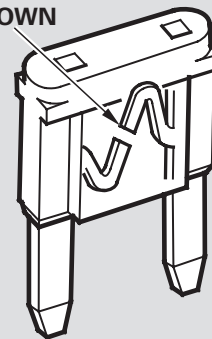

5. Look for a burned wire inside the fuse. If it is burned, replace it with one of the spare fuses of the same rating or lower.

If you cannot drive the vehicle without fixing the problem, and you do not have a spare fuse, take a fuse of the same rating or a lower rating from one of the other circuits. Make sure you can do without that circuit temporarily (such as the accessory power socket or radio).

If you replace the blown fuse with a spare fuse that has a lower rating, it might blow out again. This does not indicate anything wrong. Replace the fuse with one of the correct rating as soon as you can.

NOTICE

Replacing a fuse with one that has a higher rating greatly increases the chances of damaging the electrical system. If you do not have a replacement fuse with the proper rating for the circuit, install one with a lower rating.

6. If the replacement fuse of the same rating blows in a short time, there is probably a serious electrical problem with your vehicle. Leave the blown fuse in that circuit, and have your vehicle checked by a qualified mechanic.

If the radio fuse is removed, the audio system will disable itself. The next time you turn on the radio you will see “COdE” in the frequency display. Use the preset buttons to enter the five-digit code (see page 90).

Fuse Locations

INTERIOR FUSE BOX

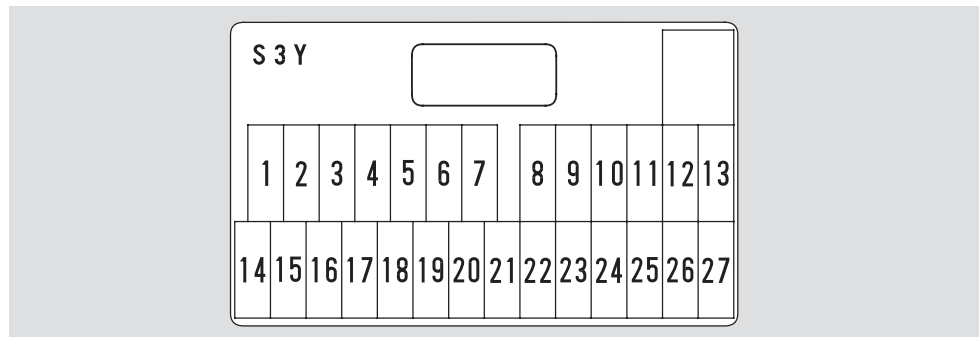

No.	Amps.	Circuits Protected
20	10 A	Radio
21	10 A	Daytime Running Light*
22	20 A	Door Lock
23	7.5 A	Tailgate Lock
24	7.5 A	IMA
25	—	Not used
26	10 A	Rear Wiper
27	7.5 A	Back Light

No.	Amps.	Circuits Protected
1	10 A	SRS
2	15 A	Fuel Pump, SRS
3	20 A	Front Wiper
4	7.5 A	FI-ECU
5	7.5 A	Turn Light
6	7.5 A	Meter
7	15 A	IG Coil
8	20 A	Power Window, Passenger
9	7.5 A	Starter Signal
10	20 A	Power Window, Driver

No.	Amps.	Circuits Protected
11	7.5 A	ACC Radio
12	10 A	ACC Socket
13	—	Not used
14	20 A	LAF Heater
15	10 A	Small Light
16	7.5 A	Air Conditioning, R/C Mirror
17	7.5 A	Daytime Running Light*
18	7.5 A	Back Up Light
19	7.5 A	Interior Light

* : Canadian model only

UNDER-HOOD FUSE BOX

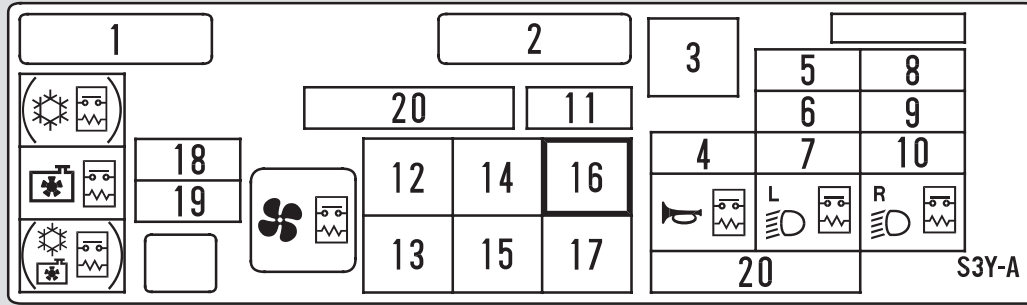

No.	Amps.	Circuits Protected
1	50 A	IG1 Main
2	80 A	Battery
3	30 A	ABS Motor
4	10 A	Hazard
5	15 A	IMA
6	10 A	Horn Stop
7	15 A	Fuel Pump
8	15 A	Left Headlight
9	—	Not used
10	15 A	Right Headlight

No.	Amps.	Circuits Protected
11	30 A	Cooling Fan
12	40 A	Heater Motor
13	30 A	Rear Defroster
14	20 A	ABS F/S
15	40 A	Power Steering
16	30 A	Back Up, ACC
17	40 A	Power Window
18	7.5 A	IMA ECU
19	20 A	Condenser Fan
20	—	Spare Fuse

The diagrams in this section give you the dimensions and capacities of your vehicle, and the locations of the identification numbers. It also includes information you should know about your vehicle's tires and emissions control systems.

- Identification Numbers..... 192
- Specifications 194
- DOT Tire Quality Grading
 (U.S. Vehicles) 196
- Uniform Tire Quality
 Grading 196
- Treadwear 196
- Traction..... 196
- Temperature 197
- Tire Labeling..... 198

- Emissions Controls..... 199
- The Clean Air Act..... 199
- Crankcase Emissions Control
 System..... 199
- Evaporative Emissions Control
 System..... 199
- Onboard Refueling Vapor
 Recovery 199
- Exhaust Emissions Controls 200
- PGM-FI System 200
- Ignition Timing Control
 System..... 200
- Three Way Catalytic
 Converter..... 200
- Replacement Parts..... 200
- Three Way Catalytic Converter... 201
- State Emissions Testing 202
- Testing of Readiness Codes..... 202

Identification Numbers

Your vehicle has several identifying numbers in various places.

The Vehicle Identification Number (VIN) is the 17-digit number your Honda dealer uses to register your vehicle for warranty purposes. It is also necessary for licensing and insuring your vehicle. The easiest place to find the VIN is on a plate fastened to the top of the dashboard. You can see it by looking through the windshield on the driver's side. It is also on the Certification label attached to the driver's doorjamb, and is stamped on the engine compartment bulkhead. The VIN is also provided in bar code on the Certification label.

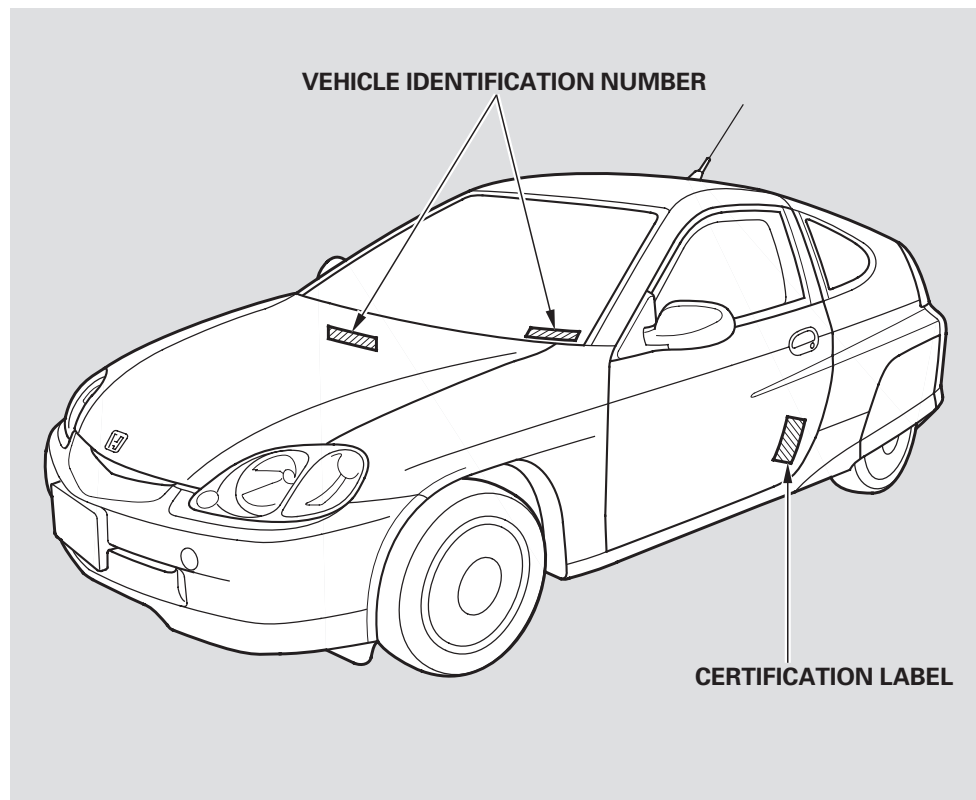

The Engine Number is stamped into the engine block.

The transmission number is on a label on top of the transmission.

The IMA Motor Number is stamped on the motor housing.

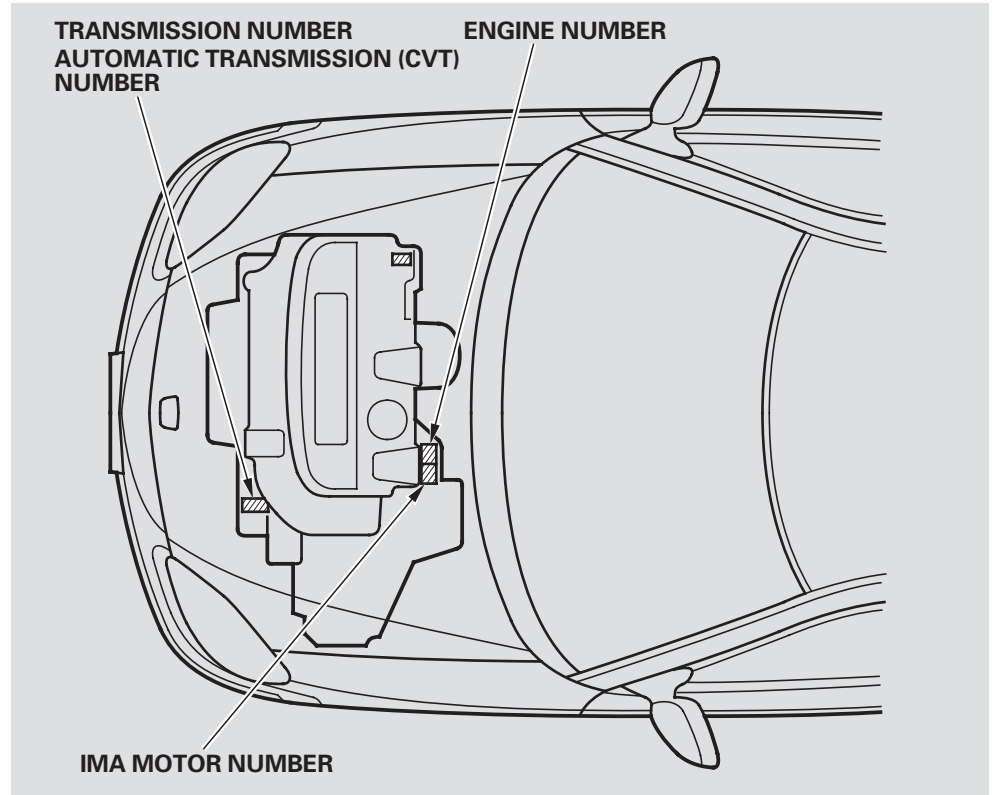

Specifications

Dimensions

Length		155.0 in (3,938 mm)
Width		66.7 in (1,695 mm)
Height		53.3 in (1,355 mm)
Wheelbase		94.5 in (2,400 mm)
Track	Front	56.5 in (1,435 mm)
	Rear	52.2 in (1,325 mm)

Weights

Gross vehicle weight rating	See the certification label attached to the driver's doorjamb.
-----------------------------	--

Engine

Type	Water cooled 4-stroke SOHC VTEC in line 3-cylinder gasoline engine	
Bore x Stroke	2.8 x 3.21 in (72 x 81.5 mm)	
Displacement	60.8 cu-in (995 cm ³)	
Compression ratio	M/T	10.8 : 1
	CVT	10.3 : 1
Spark plugs ^{*1}	ILZFR5A-11	

* 1 : Contact your Honda dealer when replacement is necessary.

Capacities

Fuel tank		Approx. 10.6 US gal (40 ℓ)
Engine coolant	Change ^{*2}	0.61 US gal (2.3 ℓ)
	Total	M/T CVT 1.03 US gal (3.9 ℓ) 1.06 US gal (4.0 ℓ)
Engine oil	Change ^{*4}	
	Including filter	2.6 US qt (2.5 ℓ)
	Without filter	2.4 US qt (2.3 ℓ)
	Total	3.2 US qt (3.0 ℓ)
Manual transmission fluid	Change	1.6 US qt (1.5 ℓ)
	Total	1.7 US qt (1.6 ℓ)
Automatic transmission fluid (CVT) ^{*3}	Change	3.5 US qt (3.3 ℓ)
	Total	5.8 US qt (5.5 ℓ)
Windshield washer reservoir		4.8 US qt (4.5 ℓ)

* 2 : Including the coolant in the reserve tank and that remaining in the engine.

Reserve tank capacity: 0.11 US gal (0.4 ℓ)

* 3 : U.S. model

* 4 : Excluding the oil remaining in the engine.

Air Conditioning

Refrigerant type	HFC-134a (R-134a)
Charge quantity	17.6–19.4 oz (500–550 g)
Lubricant type	SP-10

Lights

Headlights (HI/LO)	12 V – 60/55 W (HB2)
Front turn signal lights	12 V – 21 W
Front parking lights	12 V – 5 W
Side marker lights	12 V – 5 W
Rear turn signal lights	12 V – 21 W
Brake/Taillights	12 V – 21/5 W
Back-up lights	12 V – 18 W
Trunk light	12 V – 3.4 W
License plate light	12 V – 5 W
Interior light	12 V – 5 W

12 Volt Battery

Capacity	M/T	12 V – 27 Ah/5 HR
	CVT*	12 V – 30 Ah/5 HR

* U.S. model

Alignment

Toe-in	Front	0.00 in (0.0 mm)
	Rear	0.12 in (3.0 mm)
Camber	Front	0°
	Rear	–1°
Caster	Front	2°

Tires

Size	Front/Rear	P165/65R14 78S
	Spare	T115/70D14 88M
Pressure	Front	38 psi (260 kPa, 2.6 kgf/cm ²)
	Rear	35 psi (240 kPa, 2.4 kgf/cm ²)
	Spare	60 psi (420 kPa, 4.2 kgf/cm ²)

Fuses

Interior	See page 188 or the fuse label attached to the inside of the fuse box door under the dashboard.
Under-hood	See page 189 or the fuse box cover.

DOT Tire Quality Grading (U.S. Vehicles)

The tires on your vehicle meet all U.S. Federal Safety Requirements. All tires are also graded for treadwear, traction, and temperature performance according to Department of Transportation (DOT) standards. The following explains these gradings.

Uniform Tire Quality Grading

Quality grades can be found where applicable on the tire sidewall between the tread shoulder and the maximum section width. For example:

Treadwear 200

Traction AA

Temperature A

All passenger car tires must conform to Federal Safety Requirements in addition to these grades.

Treadwear

The treadwear grade is a comparative rating based on the wear rate of the tire when tested under controlled conditions on a specified government test course. For example, a tire graded 150 would wear one and one-half (1 1/2) times as well on the government course as a tire graded 100. The relative performance of tires depends upon the actual conditions of their use, however, and may depart significantly from the norm due to variations in driving habits, service practices, and differences in road characteristics and climate.

Traction – AA, A, B, C

The traction grades, from highest to lowest, are AA, A, B, and C. Those grades represent the tire's ability to stop on wet pavement as measured under controlled conditions on specified government test surfaces of asphalt and concrete. A tire marked C may have poor traction performance.

Warning: The traction grade assigned to this tire is based on straight-ahead braking traction tests, and does not include acceleration, cornering, hydroplaning, or peak traction characteristics.

Temperature – A, B, C

The temperature grades are A (the highest), B, and C, representing the tire's resistance to the generation of heat and its ability to dissipate heat when tested under controlled conditions on a specified indoor laboratory test wheel. Sustained high temperature can cause the material of the tire to degenerate and reduce tire life, and excessive temperature can lead to sudden tire failure. The grade C corresponds to a level of performance which all passenger car tires must meet under the Federal Motor Vehicle Safety Standard No. 109. Grades B and A represent higher levels of performance on the laboratory test wheel than the minimum required by law.

Warning: The temperature grade for this tire is established for a tire that is properly inflated and not overloaded. Excessive speed, underinflation, or excessive loading, either separately or in combination, can cause heat buildup and possible tire failure.

Tire Labeling

The tires that came on your vehicle have a number of markings. Those you should be aware of are described below.

Tire Size

Whenever tires are replaced, they should be replaced with tires of the same size. The following is an example of tire size with an explanation of what each component means.

P165/65R14 78S

P — Vehicle type (P indicates passenger vehicle).

165 — Tire width in millimeters.

65 — Aspect ratio (the tire's section height as a percentage of its width).

R — Tire construction code (R indicates radial).

14 — Rim diameter in inches.

78 — Load index (a numerical code associated with the maximum load the tire can carry).

S — Speed symbol (an alphabetical code indicating the maximum speed rating).

Tire Identification Number

Tire Identification Number (TIN) is a group of numbers and letters that look like the following example TIN.

DOT B97R FW6X 2202

DOT — This indicates that the tire meets all requirements of the U.S. Department of Transportation.

B97R — Manufacturer's identification mark.

FW6X — Tire type code.

2202 — Date of manufacture.

The burning of gasoline in your vehicle's engine produces several by-products. Some of these are carbon monoxide (CO), oxides of nitrogen (NO_x), and hydrocarbons (HC). Gasoline evaporating from the tank also produces hydrocarbons. Controlling the production of NO_x, CO, and HC is important to the environment. Under certain conditions of sunlight and climate, NO_x and HC react to form photochemical "smog." Carbon monoxide does not contribute to smog creation, but it is a poisonous gas.

The Clean Air Act

The United States Clean Air Act* sets standards for automobile emissions. It also requires that automobile manufacturers explain to owners how their emissions controls work and what to do to maintain them. This section summarizes how the emissions controls work. Scheduled maintenance is on page 129.

* In Canada, Honda vehicles comply with the Canadian emission requirements, as specified in an agreement with Environment Canada, at the time they are manufactured.

Crankcase Emissions Control System

Your vehicle has a positive crankcase ventilation system. This keeps gasses that build up in the engine's crankcase from going into the atmosphere. The positive

crankcase ventilation valve routes them from the crankcase back to the intake manifold. They are then drawn into the engine and burned.

Evaporative Emissions Control System

As gasoline evaporates in the fuel tank, an evaporative emissions control canister filled with charcoal adsorbs the vapor. It is stored in this canister while the engine is off. After the engine is started and warmed up, the vapor is drawn into the engine and burned during driving.

Onboard Refueling Vapor Recovery

The onboard refueling vapor recovery (ORVR) system captures the fuel vapors during refueling. The vapors are adsorbed in a canister filled with activated carbon. While driving, the fuel vapors are drawn into the engine and burned off.

Emissions Controls

Exhaust Emissions Controls

The exhaust emissions controls include three systems: PGM-FI, ignition timing control, and three way catalytic converter. These three systems work together to control the engine's combustion and minimize the amount of HC, CO, and NOx that comes out the tailpipe. The exhaust emissions control systems are separate from the crankcase and evaporative emissions control systems.

PGM-FI System

The PGM-FI system uses sequential multiport fuel injection. It has three subsystems: air intake, engine control, and fuel control. The powertrain control module (PCM) in automatic transmission vehicles or the engine control module (ECM) in manual transmission vehicles uses various sensors to determine how much air is going into the engine. It then controls how much fuel to inject under all operating conditions.

Ignition Timing Control System

This system constantly adjusts the ignition timing, reducing the amount of HC, CO, and NOx produced.

Three Way Catalytic Converter

The three way catalytic converter is in the exhaust system. Through chemical reactions, it converts HC, CO, and NOx in the engine's exhaust to carbon dioxide (CO₂), nitrogen (N₂), and water vapor.

Replacement Parts

The emissions control systems are designed and certified to work together in reducing emissions to levels that comply with the Clean Air Act. To make sure the emissions remain low, you should use only new Honda replacement parts or their equivalent for repairs. Using lower quality parts may increase the emissions from your vehicle.

The emissions control systems are covered by warranties separate from the rest of your vehicle. Read your warranty manual for more information.

Three Way Catalytic Converter

The three way catalytic converter contains precious metals that serve as catalysts, promoting chemical reactions to convert the exhaust gasses without affecting the metals. The catalytic converter is referred to as a three-way catalyst, since it acts on HC, CO, and NOx. A replacement unit must be an original Honda part or its equivalent.

The three way catalytic converter must operate at a high temperature for the chemical reactions to take place. It can set on fire any combustible materials that come near it. Park your vehicle away from high grass, dry leaves, or other flammables.

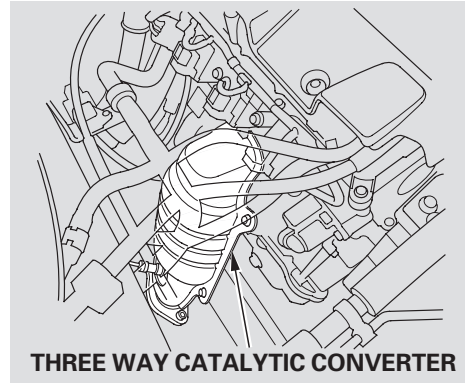

A defective three way catalytic converter contributes to air pollution, and can impair your engine's performance. Follow these guidelines to protect your vehicle's three way catalytic converter.

- Always use unleaded gasoline. Even a small amount of leaded gasoline can contaminate the catalyst metals, making the three way catalytic converter ineffective.

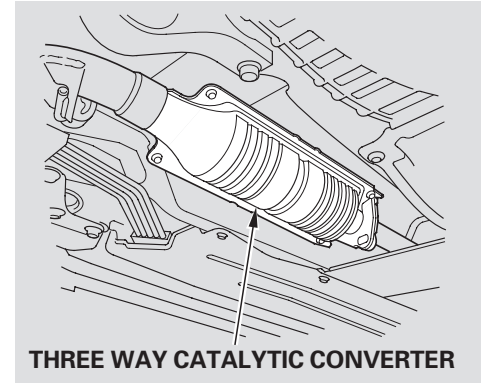

- Keep the engine tuned-up.
- Have your vehicle diagnosed and repaired if it is misfiring, back-firing, stalling, or otherwise not running properly.

State Emissions Testing

Testing of Readiness Codes

If you take your vehicle for a state emissions test shortly after the battery has been disconnected or gone dead, it may not pass the test. This is because of certain “readiness codes” that must be set in the on-board diagnostics for the emissions systems. These codes are erased when the battery is disconnected, and set again only after several days of driving under a variety of conditions.

If the testing facility determines that the readiness codes are not set, you will be requested to return at a later date to complete the test. If you must get the vehicle retested within the next two or three days, you can condition the vehicle for retesting by doing the following.

- Make sure the gas tank is nearly, but not completely full (around 3/4).
- Make sure the vehicle has been parked with the engine off for 8 hours or more.
- Make sure the ambient temperature is between 20° and 95° F.
- Without touching the accelerator pedal, start the engine, and let it idle for 20 seconds.
- Keep the vehicle in Park (automatic transmission) or Neutral (manual transmission). Increase the engine speed to 2,000 rpm, and hold it there until the temperature gauge rises to at least 1/4 of the scale (about 3 minutes).
- Select a nearby highway where you can maintain a speed of 50 to 60 mph (80 to 97 km/h) for at least 20 minutes in D (CVT) or 5th gear (M/T). When traffic allows, drive for 90 seconds without moving the accelerator pedal. (Vehicle speed may vary slightly; this is okay.) If you cannot do this for a continuous 90 seconds, drive for at least 30 seconds, then repeat it two more times (for a total of 90 seconds).
- Then drive in city/suburban traffic for at least 10 minutes. When traffic conditions allow, let the vehicle coast for several seconds without using the accelerator pedal or the brake pedal.

If the testing facility determines the readiness codes are still not set, see your dealer.

Warranty and Customer Relations

- Customer Service
 - Information..... 204
- Warranty Coverages 205
- Reporting Safety Defects (U.S. Vehicles) 206
- Authorized Manuals 207

Customer Service Information

Honda dealership personnel are trained professionals. They should be able to answer all your questions. If you encounter a problem that your dealership does not solve to your satisfaction, please discuss it with the dealership's management. The service manager or general manager can help. Almost all problems are solved in this way.

If you are dissatisfied with the decision made by the dealership's management, contact your Honda Customer Service Office.

U.S. Owners:
American Honda Motor Co., Inc.
Automobile Customer Service
Mail Stop 500-2N-7A
1919 Torrance Boulevard
Torrance, California 90501-2746

Tel: (800) 999-1009

Canadian Owners:
CUSTOMER RELATIONS
RELATIONS AVEC LA CLIENTÈLE
Honda Canada Inc.
715 Milner Avenue
Toronto, ON
M1B 2K8

Tel: 1-888-9-HONDA-9
Fax: Toll-free 1-877-939-0909
Toronto (416) 287-4776

In Puerto Rico and the U.S. Virgin Islands:

Bella International
P.O. Box 190816
San Juan, PR 00919-0816

(787) 250-4327

When you call or write, please give us this information:

- Vehicle Identification Number (see page [192](#))
- Name and address of the dealer who services your vehicle
- Date of purchase
- Mileage on your vehicle
- Your name, address, and telephone number
- A detailed description of the problem
- Name of the dealer who sold the vehicle to you

U.S. Owners

Your new vehicle is covered by these warranties:

New Vehicle Limited Warranty — covers your new vehicle, except for the battery, emissions control systems, and accessories, against defects in materials and workmanship.

Emissions Control Systems Defects Warranty and Emissions Performance Warranty — these two warranties cover your vehicle's emissions control systems. Time, mileage, and coverage are conditional. Please read your warranty manual for exact information.

Original Equipment Battery Limited Warranty — this warranty gives up to 100 percent credit toward a replacement battery.

Seat Belt Limited Warranty — a seat belt that fails to function properly is covered for the useful life of the vehicle.

Rust Perforation Limited Warranty — all exterior body panels are covered for rust-through from the inside for the specified time period with no mileage limit.

Accessory Limited Warranty — Honda accessories are covered under this warranty. Time and mileage limits depend on the type of accessory and other factors. Please read your warranty manual for details.

Replacement Parts Limited Warranty — covers all Honda replacement parts against defects in materials and workmanship.

Replacement Battery Limited Warranty — provides prorated coverage for a replacement battery purchased from your dealer.

Replacement Muffler Lifetime Limited Warranty — provides coverage for as long as the purchaser of the muffler owns the vehicle.

Restrictions and exclusions apply to all these warranties. Please read the 2005 Honda Warranty Information booklet that came with your vehicle for precise information on warranty coverages. Your vehicle's original tires are covered by their manufacturer. Tire warranty information is in a separate booklet.

Canadian Owners

Please refer to the 2005 Warranty Manual that came with your vehicle.

Reporting Safety Defects (U.S. Vehicles)

If you believe that your vehicle has a defect which could cause a crash or could cause injury or death, you should immediately inform the National Highway Traffic Safety Administration (NHTSA) in addition to notifying American Honda Motor Co., Inc.

If NHTSA receives similar complaints, it may open an investigation, and if it finds that a safety defect exists in a group of vehicles, it may order a recall and remedy campaign. However, NHTSA cannot become involved in individual problems between you, your dealer, or American Honda Motor Co., Inc.

To contact NHTSA, you may either call the Auto Safety Hotline toll-free at 1-800-424-9393 (or 366-0123 in Washington D.C. area) or write to: NHTSA, U.S. Department of Transportation, Washington, D.C. 20590. You can also obtain other information about motor vehicle safety from the Hotline.

Purchasing Factory Authorized Manuals (U.S. only)

The publications shown below can be purchased from Helm Incorporated. You can order in any of three ways:

- Detach and mail the order form on the right half of this page
- Call Helm Inc. at 1-800-782-4356 (credit card orders only)
- Go online at www.helminc.com

If you are interested in other years or models, contact Helm Inc. at 1-800-782-4356.

Publication Form Number	Form Description	Price Each*
61S3Y06	2000-05 Honda Insight Service Manual	\$70.00
61S3Y06EL	2000-05 Honda Insight Electrical Troubleshooting Manual	\$50.00
61S3Y30	2000-05 Honda Insight Body Repair Manual	\$44.00
31S3Y660	2005 Honda Insight Owner's Manual	\$34.00
31S3YM00	2005 Honda Insight Honda Service History	\$12.00
31S3YQ20	2005 Honda Insight Quick Start Guide	\$12.00
HON-R	Order Form for Previous Years- Indicate Year and Model Desired	FREE

* Prices are subject to change without notice and without incurring obligation.

Valid only for sales within the United States. Canadian owners should contact their authorized Honda dealer.

ORDER TOLL FREE: 1-800-782-4356
(NOTE: For Credit Card Holder Orders Only)
 Monday-Friday 8:00 A.M. — 6:00 P.M. EST
MINIMUM CREDIT CARD PURCHASE \$10.00

OR

By completing this form you can order the materials desired. You can pay by check or money order, or charge to your credit card. Mail to Helm Incorporated at the address shown on the back of the order form.

2005 HON	PUBLICATION NUMBER	VEHICLE MODEL		Qty	Price Each*	Total Price
		Name	Year			
* Prices are subject to change without notice and without incurring obligation. Orders are mailed within 10 days. Please allow adequate time for delivery.				TOTAL MATERIAL		
				Mich. Purchases Add 6% Sales Tax		
				HANDLING CHARGE	\$6.95	
				GRAND TOTAL		

A

Accessories..... 101

ACCESSORY (Ignition Key Position) 61

Accessory Power Socket 71

Additives, Engine Oil..... 136

Airbag (SRS) 11, 21

Airbags, Additional Information 21

 Additional Safety Precautions... 24

 Airbag Service..... 23

 How the SRS Indicator Works... 23

 How Your Front Airbags Work..... 21

 SRS Components 21

Air Conditioning System..... 74

 Usage 75, 78

Air Pressure, Tires 156

 Normal Driving 157

Alcohol in Gasoline..... 94

Antifreeze 139

Anti-lock Brakes (ABS)

 Indicator..... 45, 122

 Operation122

Anti-theft, Audio System..... 90

Anti-theft Steering Column

 Lock..... 61

Audio System 80

Auto Idle Stop..... 111, 118

Automatic Seat Belt Tensioners 19

Automatic Transmission..... 113

 Capacity, Fluid 194

 Checking Fluid Level..... 142

 Shifting..... 114

 Shift Lever Position

 Indicators..... 113

 Shift Lever Positions 114

 Shift Lock Release..... 117

B

Battery

 Charging System

 Indicator..... 44, 180

 Jump Starting 175

 Maintenance..... 162

 Specifications 195

Before Driving 93

Belts, Seat 10, 18

Beverage Holder..... 71

Booster Seats 35

Brakes

 Anti-lock System (ABS) 122

 Break-in, New Linings..... 94

 Bulb Replacement 149

 Fluid 144

 Parking..... 69

 System Indicator..... 45, 182

 Wear Indicators 121

Braking System..... 121

Break-in, New Vehicle 94

Brightness Control, Instruments... 57

Brights, Headlights 56

Bulb Replacement

 Back-up Lights 149

 Brake Lights..... 149

 Front Parking Lights..... 147

 Front Side Marker Lights..... 148

 Headlights 146

 Specifications 195

 Turn Signal Lights..... 148

Bulbs, Halogen..... 146

CONTINUED

Index

C

Capacities Chart.....	194
Carbon Monoxide Hazard	38
Carrying Cargo	103
CAUTION, Explanation of	ii
CD Care	87
CD Player Error Message	88
CD Changer Error Message	89
CD Player.....	85
Ceiling Light.....	72
Certification Label.....	192
Chains, Tires	161
Charge/Assist Gauge	53
Changing a Flat Tire	167
Changing Oil	
How to.....	136
When to.....	129
Charging System Indicator	44, 180
Checklist, Before Driving.....	108
Child Safety	25
Booster Seats	35
Child Seats.....	30
Important Safety Reminders.....	28
Infants	26
Large Children	34

Risks with Airbags.....	26
Small Children.....	29
Tethers.....	33
Where Should a Child Sit?	25
Child Seats	
Installing a Child Seat	30
Selecting Child Seat.....	30
Tether Anchorage Points	33
Clock.....	91
Clutch Fluid.....	145
CO in the Exhaust	199
Cold Weather, Starting in	109
Compact Spare Tire.....	166
Consumer Information *	204
Controls, Instruments and.....	41
Coolant	
Adding.....	139
Checking.....	98
Proper Solution	139
Temperature Gauge	49
Crankcase Emissions Control	
System.....	199
Cup Holders.....	71
Current Fuel Mileage.....	50
Customer Service Office	204

D

DANGER, Explanation of	ii
Dashboard	4, 42
Daytime Running Lights.....	56
Daytime Running Lights	
Indicator	46
Dead Battery	175
Defects, Reporting Safety.....	206
Defog and Defrost.....	77
Defogger, Rear Window	58
Defrosting the Windows.....	77
Dimensions.....	194
Dimming the Headlights	56
Dipstick	
Automatic Transmission	
(CVT)	142
Engine Oil.....	97
Directional Signals.....	56
Disc Brake Wear Indicators.....	121
Disposal of Used Oil.....	138
Display Change Button.....	49
Doors	
Locking and Unlocking.....	62
Power Door Locks.....	62
DOT Tire Quality Grading	196

Downshifting, Manual
Transmission..... 110

Driver and Passenger Safety..... 7

Driving 107

 Economy 99

Dust and Pollen Filter 152

E

Economy, Fuel 99

Emergencies on the Road..... 165

 Battery, Jump Starting 175

 Brake System Indicator 182

 Changing a Flat Tire 167

 Charging System Indicator 180

 Checking the Fuses..... 185

 Hazard Warning Button..... 57

 Jump Starting 175

 Low Oil Pressure Indicator 179

 Malfunction Indicator Lamp 180

 Overheated Engine 177

 Towing 183

Emergency Brake..... 69

Emergency Flashers 57

Emergency Towing 183

Emissions Controls..... 199

Emissions Testing, State 202

Engine

 Coolant Temperature Gauge 49

 Engine Speed Limiter 111, 116

 If It Won't Start 173

 Malfunction Indicator
 Lamp 45, 180

 Oil Pressure Indicator 44, 179

 Oil, What Kind to Use..... 135

 Overheating..... 177

 Specifications 194

 Starting..... 109

Ethanol in Gasoline 94

Evaporative Emissions Controls.. 199

Exhaust Fumes 38

Expectant Mothers, Use of Seat
 Belts by 16

F

Fan, Interior..... 75

Features 73

Filling the Fuel Tank..... 95

Filter

 Dust and Pollen..... 152

 Oil 136

Flashers, Hazard Warning..... 57

Flat Tire, Changing a 167

Fluids

 Automatic Transmission
 (CVT) 142

 Brake..... 144

 Clutch..... 145

 Manual Transmission 143

 Windshield Washer 141

FM Stereo Radio

 Reception 83

Four-way Flashers 57

Front Airbags 11, 21

Fuel..... 94

 Fill Door and Cap..... 95

 Gauge 49

 Octane Requirement..... 94

 Oxygenated 94

 Reserve Indicator..... 46

 Tank, Filling the..... 95

Fuses, Checking the..... 185

CONTINUED

Index

G

Gas Mileage, Improving.....	99
Gasoline	94
Fuel Reserve Indicator.....	46
Gauge	49
Octane Requirement	94
Tank, Filling the.....	95
Gas Station Procedures.....	95
Gauges	
Engine Coolant Temperature	49
Fuel.....	49
Gearshift Lever Positions	
Automatic Transmission	
(CVT)	113
Manual Transmission	110
Glove Box	71

H

Halogen Headlight Bulbs.....	146
Hatch	
Opening the	63
Open Monitor Indicator	46
Hazard Warning Button.....	57

Headlights

Aiming.....	146
Daytime Running Lights	46, 56
High Beam Indicator.....	46
Reminder Tone	56
Replacing Halogen Bulbs	146
Turning on.....	56
Heating.....	76
High Altitude, Starting at.....	109
High-Low Beam Switch	56
Hood, Opening the	96
Horn.....	54
Hydraulic Clutch.....	145

I

Identification Number, Vehicle....	192
Ignition	
Keys.....	59
Switch.....	61
Timing Control System.....	200
IMA System Indicator	44
Important Safety Precautions	8
Indicators	44
ABS (Anti-lock Brake)	45, 122

Brake (Parking and Brake

System)	45, 182
Charging System	44, 180
DRL (Daytime Running	
Lights).....	46
High Beam.....	46
IMA.....	44
Key (Immobilizer System)	46
Low Fuel	46
Low Oil Pressure	44, 179
SRS	23, 44
Turn Signal and Hazard	
Warning	45
Infant Seats.....	26
Inflation, Proper Tire	156
Normal Driving	157
Inside Mirror	68
Inspection, Tire	158
Instrument Panel	43
Instrument Panel Brightness	57
Interior Lights	72
Introduction.....	i

J

Jacking up the Vehicle 169
Jack, Tire 167
Jump Starting 175

K

Keys..... 59

L

Label, Certification..... 192
Lane Change, Signaling 56
Lap/Shoulder Belt..... 14, 18
Lifetime Fuel Mileage..... 51
Lights
 Bulb Replacement 146
 Indicators..... 44
 Parking..... 56
 Turn Signal..... 56
Load Limit 104
LOCK (Ignition Key Position) 61
Locks
 Anti-theft Steering Column 61
 Fuel Fill Door 95

Hatch..... 62
 Power Door 62
Low Coolant Level..... 98
Low Fuel Indicator 46
Lower Gear, Downshifting to a.... 110
Low Oil Pressure Indicator 44, 179
Lubricant Specifications Chart 194
Luggage, Storing (Cargo) 103

M

Maintenance..... 125
 Owner's Maintenance
 Checks 128
 Record..... 131
 Required Indicator..... 47
 Safety..... 126
 Schedule 127
Malfunction Indicator Lamp .. 45, 180
Manual Transmission..... 110
 Checking Fluid Level..... 143
 Shifting the 110
Manual Transmission Fluid 143
Meters, Gauges..... 43, 48
Mirrors, Adjusting 68
Modifying Your Vehicle..... 102

N

Neutral Gear Position..... 114
New Vehicle Break-in 94
NOTICE, Explanation of..... ii
Numbers, Identification..... 192

O

Octane Requirement, Gasoline..... 94
Odometer..... 49
Odometer, Trip 50
Oil
 Change, How to 136
 Change, When to 129
 Checking Engine 97
 Pressure Indicator 44, 179
 Selecting Proper Viscosity
 Chart 136
ON (Ignition Key Position) 61
Onboard Refueling Vapor
 Recovery 199
Opening the Hatch 63
Outside Mirrors 68

CONTINUED

Index

Overheating, Engine	177
Owner's Maintenance Checks	128
Oxygenated Fuels.....	94

P

Panel Brightness Control	57
Park Gear Position.....	114
Parking.....	120
Parking Brake	69
Parking Brake and Brake System Indicator.....	45, 182
Parking Lights.....	56
Parking Over Things that Burn...	120
Playing the Radio	80
Playing a CD.....	85
PGM-FI System.....	200
Power Socket Location	70
Power Windows	67
Pregnancy, Using Seat Belts	16
Protecting Adults and Teens.....	12
Additional Safety Precautions....	17
Advice for Pregnant Women.....	16
Protecting Children	25
General Guidelines.....	25

Using Child Seats with Tethers.....	33
Protecting Larger Children	34
Protecting Small Children	29

R

Radiator Overheating.....	177
Radio/CD Sound System.....	80
Readiness Codes.....	202
Rear Lights, Bulb Replacement...	149
Rear View Mirror.....	68
Rear Window Defogger	58
Rear Window Washer	55
Rear Window Wiper	55
Reclining the Seat Backs	66
Reminder Lights	44
Remote Transmitter.....	64
Replacement Information	
Dust and Pollen Filter	152
Engine Oil and Filter.....	136
Floor Mats	151
Fuses	185
Light Bulbs	146
Schedule	129
Seat Belts.....	151

Tires	159
Wiper Blades.....	153
Replacing Seat Belts After a Crash.....	19
Reserve Tank, Engine	
Coolant.....	98, 139
Restraint, Child	25
Reverse Gear Position.....	114
Roof Antenna	152
Rotation, Tire	159

S

Safety Belts.....	10, 18
Safety Defects, Reporting*	206
Safety Features	9
Airbags.....	11
Seat Belts	10
Safety Labels, Location of	39
Safety Messages.....	ii

Seat Belts 10, 18
 Additional Information 18
 Automatic Seat Belt
 Tensioners 19
 Cleaning 151
 Lap/Shoulder Belt 18
 Maintenance 19
 Reminder Indicator and
 Beeper 18, 44
 System Components 18
 Use During Pregnancy 16
 Wearing a Lap/Shoulder Belt ... 14
 Seats, Adjusting the 66
 Serial Number 192
 Service Intervals 129
 Service Manual* 207
 Service Station Procedures 95
 Setting the Clock 91
 Shift Lever Position Indicators 113
 Shift Lock Release 117
 Side Marker Lights, Bulb
 Replacement 148, 149
 Signaling Turns 56
 Snow Tires 161
 Sound System 80

Spare Tire
 Inflating 166
 Specifications 195
 Specifications Charts 194
 Spotlights 72
 SRS, Additional Information 21
 Additional Safety Precautions ... 24
 Airbag Service 23
 How the SRS Indicator
 Works 23
 How Your Front Airbags
 Work 21
 SRS Components 21
 SRS Indicator 23, 44
 START (Ignition Key Position) 61
 Starting the Engine 109
 In Cold Weather at High
 Altitude 109
 With a Dead Battery 175
 State Emissions Testing 202
 Steam Coming from Engine 177
 Steering Wheel
 Anti-theft Column Lock 61
 Stereo Sound System 80
 Storing Your Vehicle 163

Supplemental Restraint
 System 11, 21
 Servicing 23
 SRS Indicator 23, 44
 System Components 21
 Synthetic Oil 136

T

Taillights, Changing Bulbs in 149
 Taking Care of the
 Unexpected 165
 Technical Descriptions
 DOT Tire Quality Grading 196
 Emissions Control Systems 199
 State Emissions Testing 202
 Three Way Catalytic
 Converter 201
 Temperature Gauge 49
 Temperature, Inside Sensor 79
 Tether Anchorage Points 33
 Theft Protection 90
 Three Way Catalytic Converter ... 201
 Time, Setting the 91

CONTINUED

Index

Tire Chains	161
Tire, How to Change a Flat	167
Tire Information	198
Tire Labeling	198
Tires	156
Air Pressure	157
Checking Wear	158
Compact Spare	166
DOT Tire Quality Grading	196
Inflation	156
Inspection	158
Maintenance.....	158
Replacing	159
Rotating.....	159
Snow.....	161
Specifications	195
Tire Chains.....	161
Tools, Tire Changing	167
Towing	
A Trailer.....	123
Emergency Wrecker	183
Traction Devices.....	161
Transmission	
Checking Fluid Level, Automatic (CVT)	142

Checking Fluid Level, Manual	143
Fluid Selection	142, 143
Identification Number.....	193
Shifting the Manual.....	110
Treadwear	196
Trip Meters	50
Trip Mileage.....	50
Turn Signals	56

U

Unexpected, Taking Care of the	165
Uniform Tire Quality Grading	196
Unleaded Gasoline.....	94
Used Oil, How to Dispose of	138

V

Vehicle Capacity Load	104
Vehicle Dimensions.....	194
Vehicle Identification Number....	192
Vehicle Storage	163
VIN	192
Viscosity, Oil.....	136

W

WARNING, Explanation of	ii
Warning Labels, Location of	39
Warranty Coverages*	205
Washer, Windshield	
Checking the Fluid Level	141
Operation	55
Wheels	
Alignment and Balance.....	158
Compact Spare	166
Wrench	169
Windows	
Cleaning	55
Operating the Power	67
Rear, Defogger	58
Windshield	
Cleaning	55
Defroster	77
Washers	55
Wipers, Windshield	
Changing Blades.....	153
Operation	55
Worn Tires	158
Wrecker, Emergency Towing.....	183
* U.S. and Canada only	

Service Information Summary

Gasoline:

Unleaded gasoline, pump octane number of 86 or higher.

Fuel Tank Capacity:

10.6 US gal (40 ℓ)

Recommended Engine Oil:

API Premium grade 0W-20 detergent oil (see page [135](#)).

Oil change capacity (including filter):

2.6 US qt (2.5 ℓ)

Automatic Transmission Fluid (CVT):

Use Honda ATF-Z1 (Automatic Transmission Fluid) only.

Capacity:

5.8 US qt (5.5 ℓ)

Manual Transmission Fluid:

Honda Manual Transmission Fluid preferred, or an SAE 10W-30 or 10W-40 motor oil as a temporary replacement (see page [143](#)).

Capacity (including differential):

1.6 US qt (1.5 ℓ)

Brake Fluid:

Honda Heavy Duty Brake Fluid DOT 3 preferred, or a DOT 3 or DOT 4 brake fluid as a temporary replacement (see page [144](#)).

Tire Pressure (measured cold):

Front:

38 psi (260 kPa , 2.6 kgf/cm²)

Rear:

35 psi (240 kPa , 2.4 kgf/cm²)

Spare Tire:

60 psi (420 kPa , 4.2 kgf/cm²)