

This owner's manual should be considered a permanent part of the vehicle and should remain with the vehicle when it is sold.

This owner's manual covers all models of your vehicle. You may find descriptions of equipment and features that are not on your particular model.

Images throughout this owner's manual (including the front cover) represent features and equipment that are available on some, but not all, models. Your particular model may not have some of these features.

The information and specifications included in this publication were in effect at the time of approval for printing. Honda Motor Co., Ltd. reserves the right, however, to discontinue or change specifications or design at any time without notice and without incurring any obligation.

## ➤ Safe Driving P. 29

For Safe Driving P. 30      Seat Belts P. 34      Airbags P. 41

## ➤ Instrument Panel P. 69

Indicators P. 70      Gauges and Multi-Information Displays P. 81

## ➤ Controls P. 97

Locking and Unlocking the Doors P. 98  
Opening and Closing the Windows P. 109  
Adjusting the Seats P. 120  
Interactive Remote P. 136

## ➤ Features P. 141

Audio System P. 142

## ➤ Driving P. 143

Before Driving P. 144      When Driving P. 150  
Charging P. 171      Energy Economy P. 184

## ➤ Maintenance P. 187

Before Performing Maintenance P. 188      Maintenance Minder™ P. 191  
Checking and Maintaining Wiper Blades P. 207  
Interactive Remote Care P. 222

## ➤ Handling the Unexpected P. 227

Tools P. 228      If a Tire Goes Flat P. 229  
Indicator, Coming On/Blinking P. 242      Fuses P. 245  
When You Cannot Open the Charge Lid P. 252

## ➤ Information P. 253

Specifications P. 254      Identification Numbers P. 255  
Warranty Coverages P. 258      Authorized Manuals P. 259

# Contents

Child Safety P. 56

Safety Labels P. 68

Opening and Closing the Tailgate P. 105

Operating the Switches Around the Steering Wheel P. 111

Interior Lights/Interior Convenience Items P. 126

Security System P. 107

Adjusting the Mirrors P. 119

Climate Control System P. 133

Braking P. 165

Modifications P. 185

Parking Your Vehicle P. 169

Rearview Camera P. 170

Maintenance Schedule P. 193

Checking and Maintaining Tires P. 211

Climate Control System Maintenance P. 223

Maintenance Under the Hood P. 195

12 Volt Battery P. 220

Replacing Light Bulbs P. 202

Remote Transmitter Care P. 221

Cleaning P. 224

Power System Won't Start P. 237

Emergency Towing P. 250

Jump Starting P. 238

When You Cannot Open the Tailgate P. 251

Shift Lever Does Not Move P. 240

Devices that Emit Radio Waves P. 256

Customer Service Information P. 260

Reporting Safety Defects P. 257

Quick Reference Guide P. 2

Safe Driving P. 29

Instrument Panel P. 69

Controls P. 97

Features P. 141

Driving P. 143

Maintenance P. 187

Handling the Unexpected P. 227

Information P. 253

Index P. 261

# Visual Index

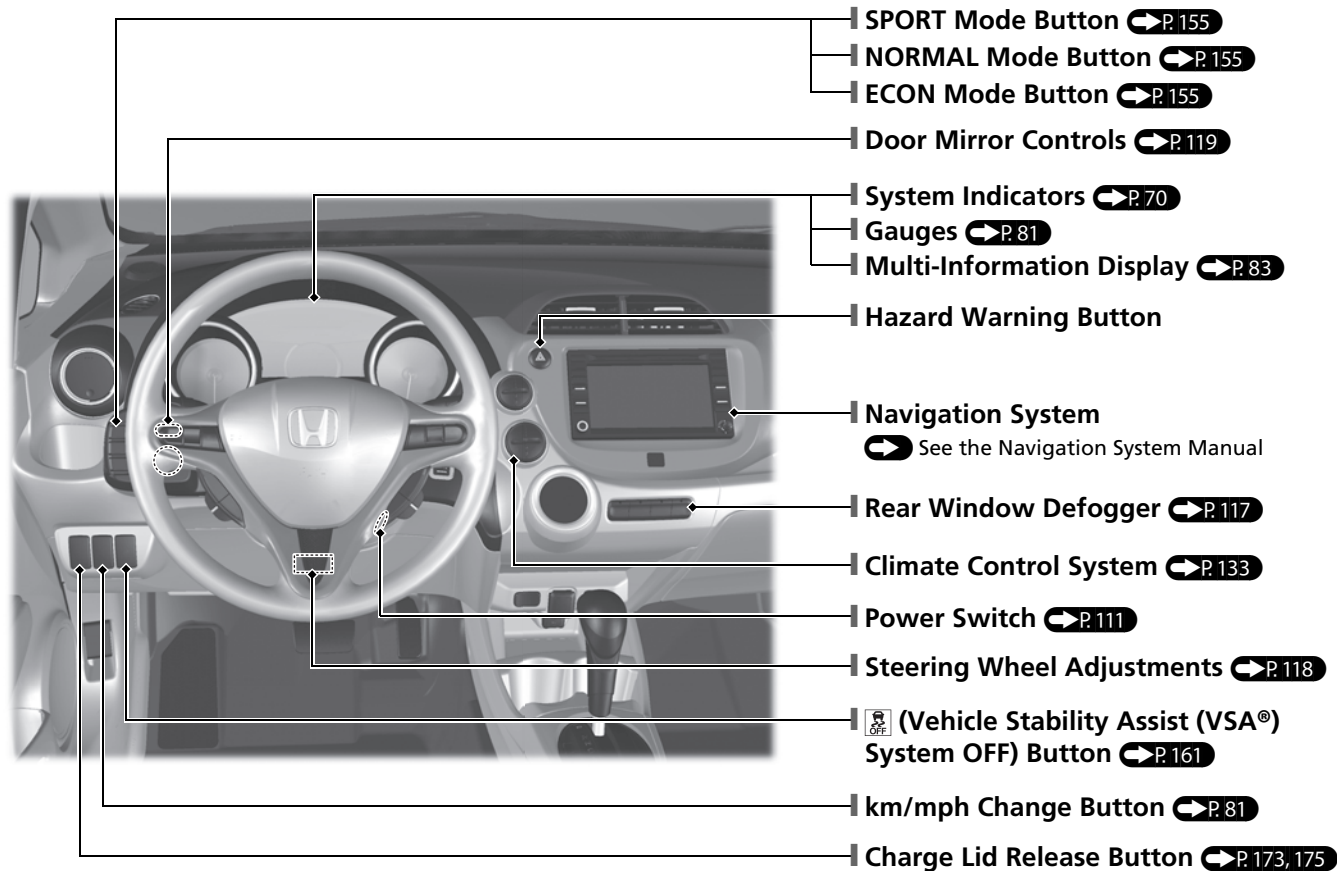

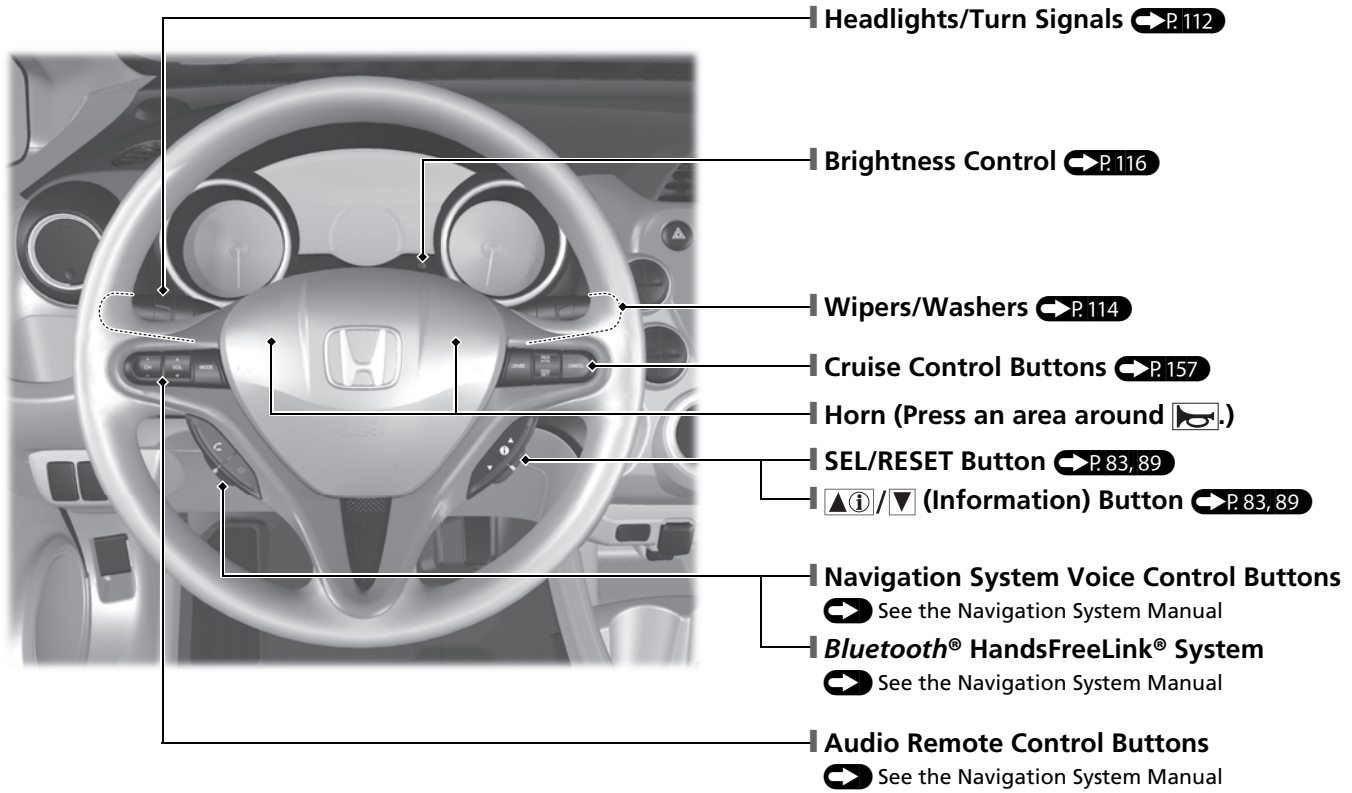

Headlights/Turn Signals ➔ P.112

Brightness Control ➔ P.116

Wipers/Washers ➔ P.114

Cruise Control Buttons ➔ P.157

Horn (Press an area around )

SEL/RESET Button ➔ P.83, 89

 (Information) Button ➔ P.83, 89

Navigation System Voice Control Buttons  
➔ See the Navigation System Manual

Bluetooth® HandsFreeLink® System  
➔ See the Navigation System Manual

Audio Remote Control Buttons  
➔ See the Navigation System Manual

# Visual Index

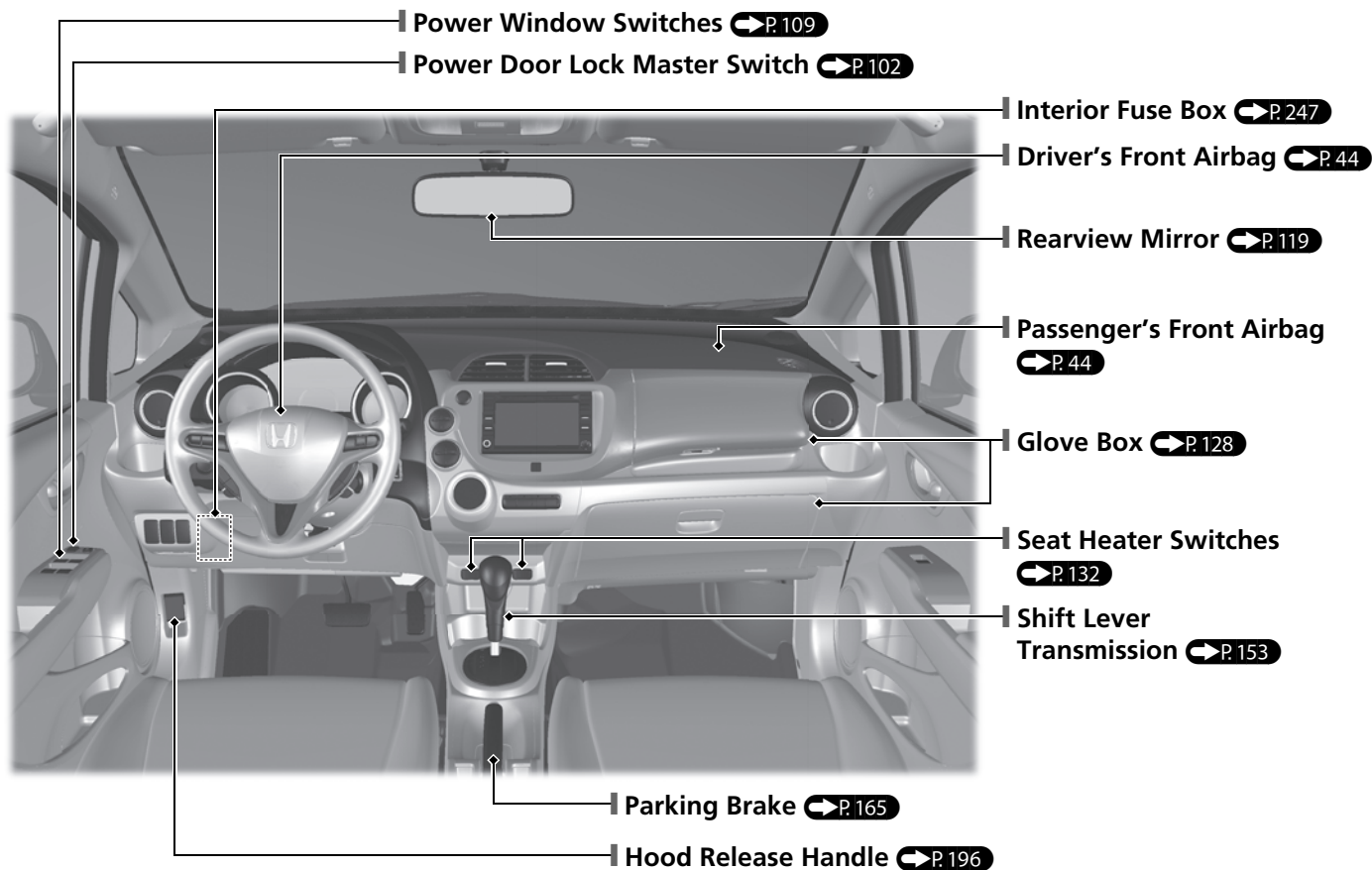

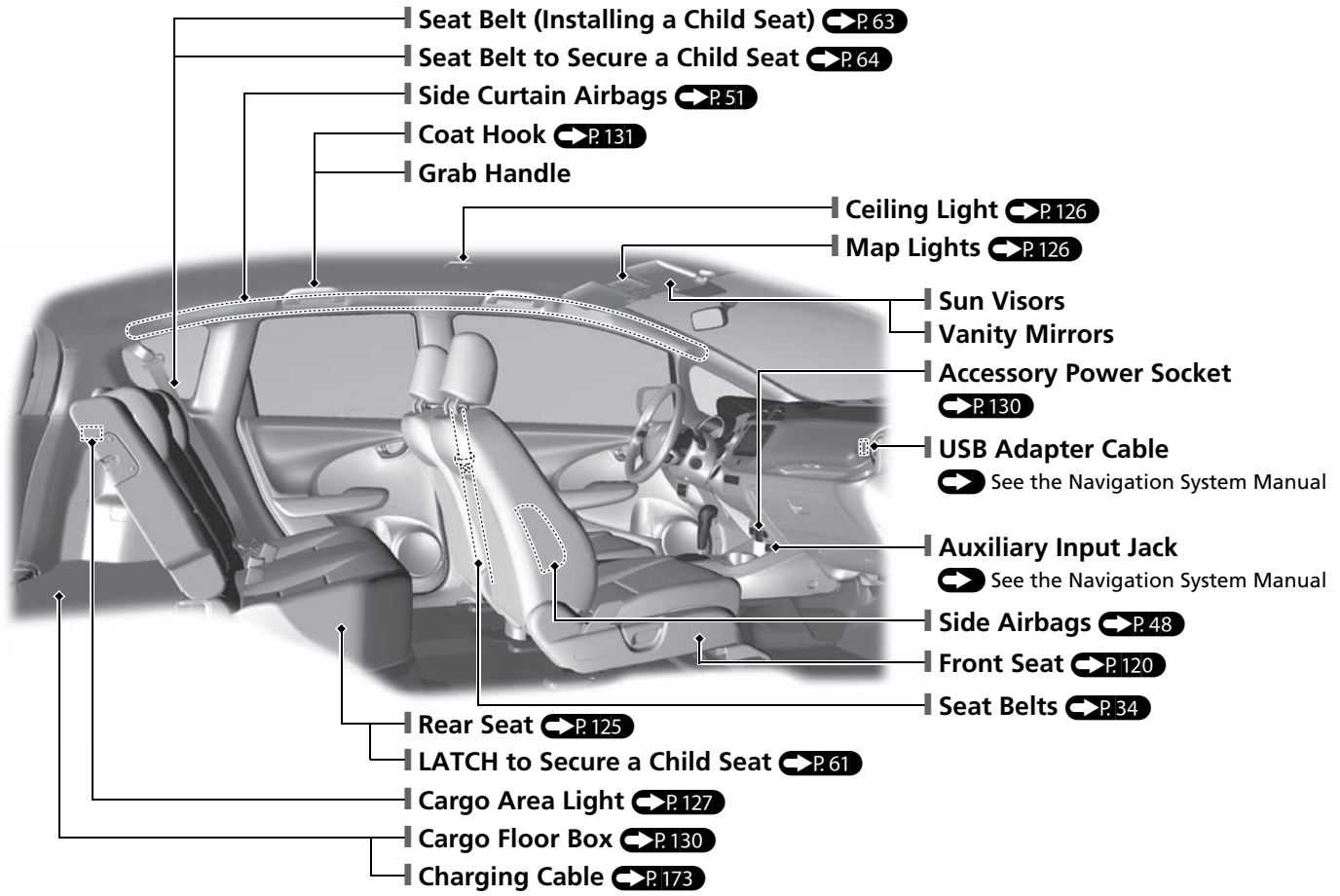

# Visual Index

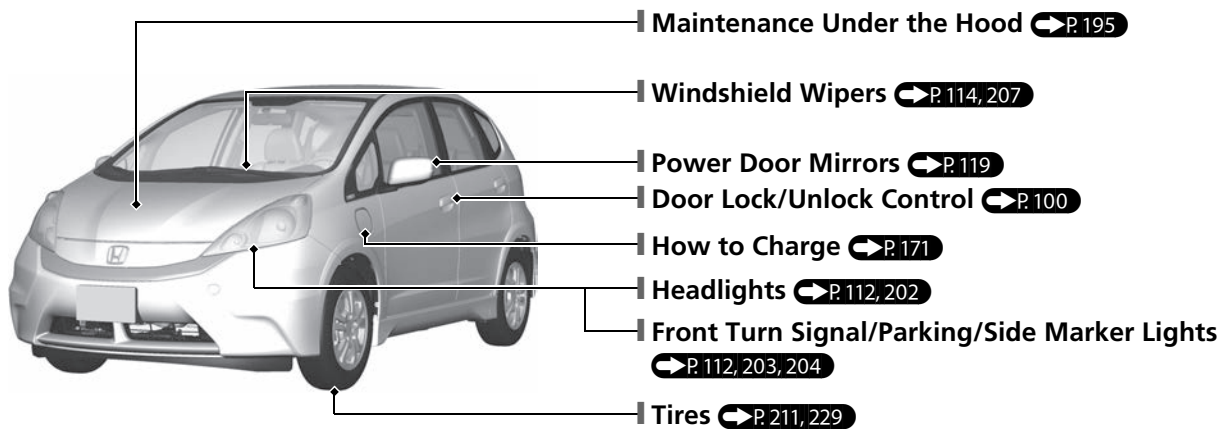

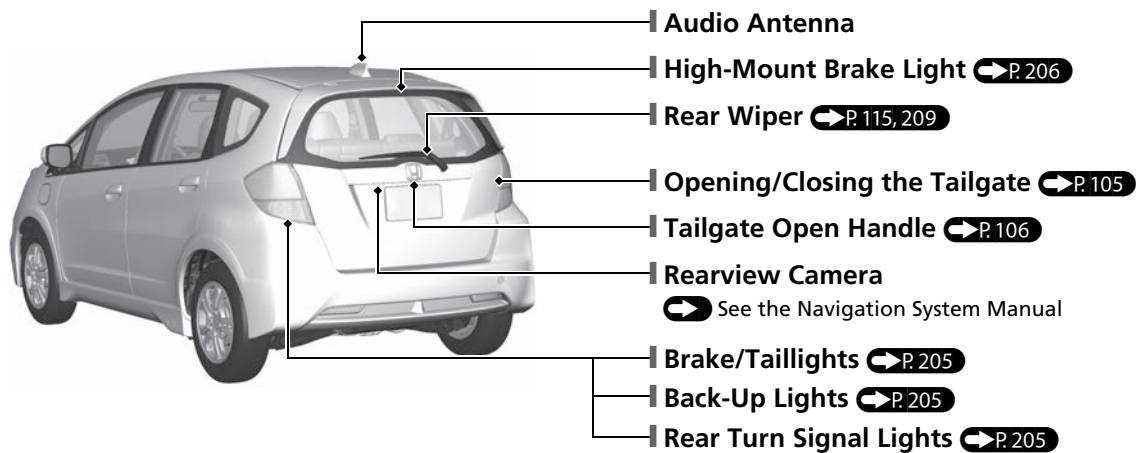



# Making Good Use of Your Honda Electric Vehicle



## Select Your Preferable Driving Performance.

Using the 3-mode drive system, an extended range can be achieved.

➤ **3-Mode Drive System** P. 14, 155



## Charging at Home

Your Honda electric vehicle can be charged with an appropriately configured household outlet. If a timer has been set, charging automatically starts and ends.

➤ **Charging** P. 171, 174

➤ **Using a Timer** P. 182

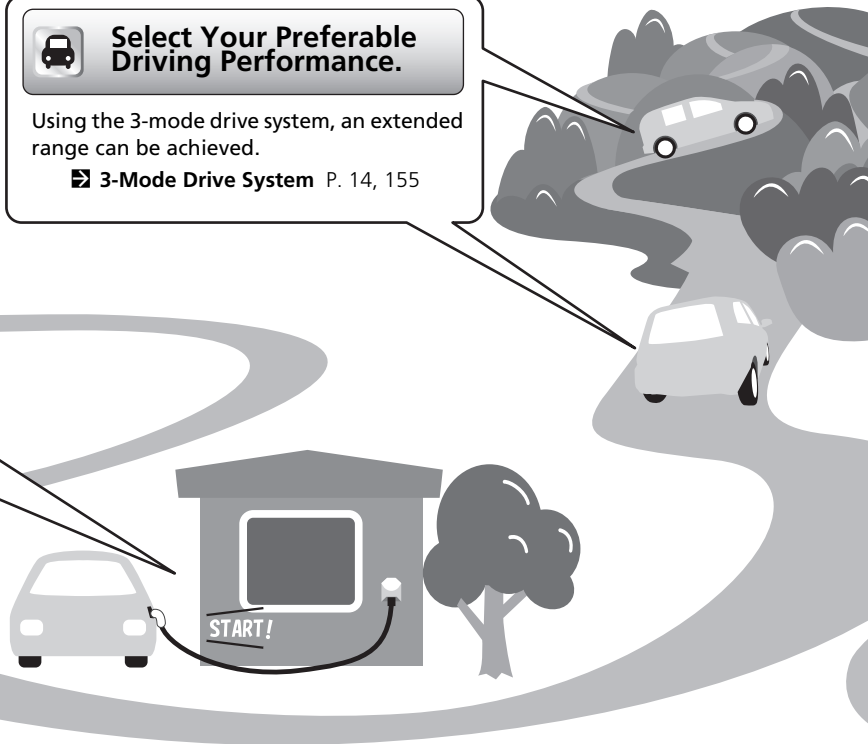



## Parking

There are several things you need to know when parking your Honda electric vehicle.

➤ **High Voltage Battery** P. 181



## How the electric vehicle works

An electric motor propels your Honda electric vehicle.

➤ **How the Electric Vehicle Works**  
P. 10

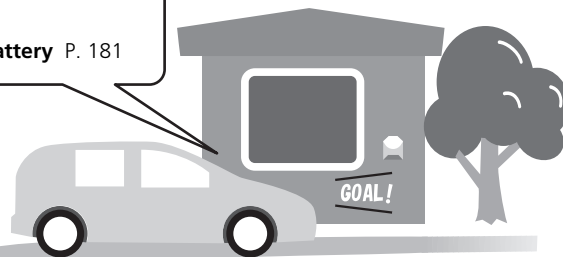

# How the Electric Vehicle Works

Instead of using gasoline to power an internal combustion engine, your vehicle uses stored electricity to power an electric propulsion motor. When decelerating, or going down hills, the electric propulsion motor also acts as a generator to recover a portion of the electrical energy that was used to accelerate the vehicle. This regenerative braking works in a manner similar to engine braking on a gasoline powered vehicle, and is enhanced with the shift lever in **B**.

As with a gasoline powered vehicle, the efficiency of an electric vehicle (and the vehicle's range) is most impacted by the driver's driving style. Climate control system usage also has a strong impact with heavy usage negatively affecting the vehicle's range.

There are two types of batteries used in this vehicle, a standard 12 volt battery that powers the airbags, the interior and exterior lights, and other standard 12 volt systems, and a high voltage lithium ion battery that is used to power the propulsion motor and recharge the 12 volt battery.

## High Voltage Battery

Learning about the High Voltage battery's characteristics will help you get the best handling and maximize the range of your electric vehicle.

➔ P. 181

## Charging the High Voltage Battery

You can recharge the High Voltage battery using a standard household outlet or at a public charging station.

➔ P. 171

# Safety Precautions

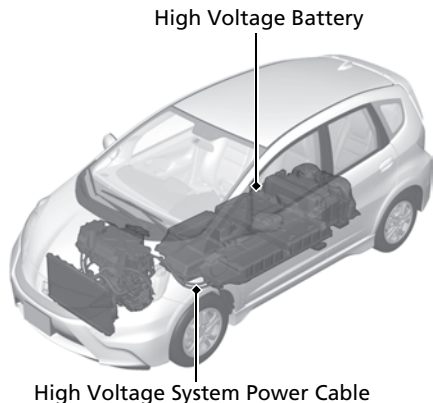

## Do not touch the High Voltage system

As much as 400 volts runs through the High Voltage system. Attempting to take a system component apart or disconnect one of its wires can cause severe electrical shock. If the High Voltage system needs maintenance or repairs, it should be performed at an authorized Honda Fit EV dealer.

## If a crash occurs

- Be careful of electric shock hazard.
  - ▶ If a severe crash damaged your vehicle's High Voltage system, there is a possibility of electrical shock due to exposed High Voltage components or wires. If this happens, do not touch any of the High Voltage system components or any of its orange wires.
- Avoid contact with High Voltage battery fluid.
  - ▶ The High Voltage battery contains a flammable electrolyte that could leak as a result of a severe crash. Avoid any skin or eye contact with the electrolyte as it is corrosive. If you accidentally touch it, flush your eyes or skin with a large quantity of water for at least five minutes, and seek medical attention immediately.
- Use a fire extinguisher for an electrical fire.
  - ▶ Attempting to extinguish an electrical fire with a small quantity of water, from a garden hose for instance, can be dangerous.
- Anytime the vehicle is damaged in an accident, have it repaired by an authorized Honda Fit EV dealer.

## Emergency Shutdown System for the High Voltage System

The emergency shutdown system may activate when the vehicle is impacted by some incident such as a crash and a collision. When this system activates, the High Voltage system automatically shuts down, and your vehicle no longer moves.

To recover the High Voltage system back in operation, consult an authorized Honda Fit EV dealer.

Honda collects and recycles used High Voltage batteries used in its vehicles – consult an authorized Honda Fit EV dealer for more information.

# Eco Assist System

## Ambient Meter

- Changes color to reflect your driving style.  
Green: Energy efficient driving  
Light green: Moderate acceleration/deceleration  
White: Aggressive acceleration/deceleration
- Changes to constant red when SPORT mode is selected.
- The ambient meter color changes in accordance with your brake or accelerator pedal operation.



## Drive Cycle Score/Lifetime Points

- Comes on when the power switch is in LOCK [0].

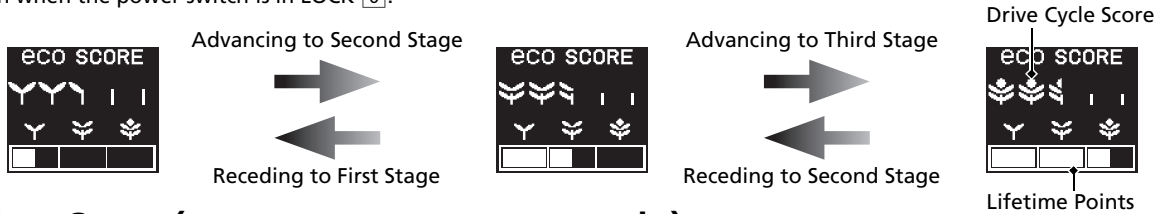

## Real Time Score (represents your current trip) P.87

- Each time you turn the power switch to ON [II], the ecological screen starts without any leaves on the plants. Leaves accumulate or diminish based on your driving style during the current trip.



## Feedback with Eco Drive Bar P.88

- Keep the bar from extending too much to the left or right side. The shorter the bar is while driving, the higher the fuel economy becomes.

The bar extends to the right when you press the accelerator pedal.	Slow, steady acceleration/ Maximizes fuel economy	Moderate acceleration	Aggressive/Inconsistent acceleration
The bar extends to the left when you press the brake pedal.	Slow deceleration/ Maximizes fuel economy	Moderate deceleration	Aggressive deceleration

# 3-Mode Drive System

There are three driving modes for your vehicle: SPORT, NORMAL, and ECON. Each mode offers a different level of driving performance. The mode buttons are located on the control panel.

## POWER/CHARGE Gauge (with SPORT Mode)

- The **POWER/CHARGE** gauge extends to indicate increased power.



Changes the color to reflect your driving mode.

SPORT Mode: Red  
NORMAL Mode: White  
ECON Mode: Green

## Range Display

The displayed range changes by your selected driving mode.

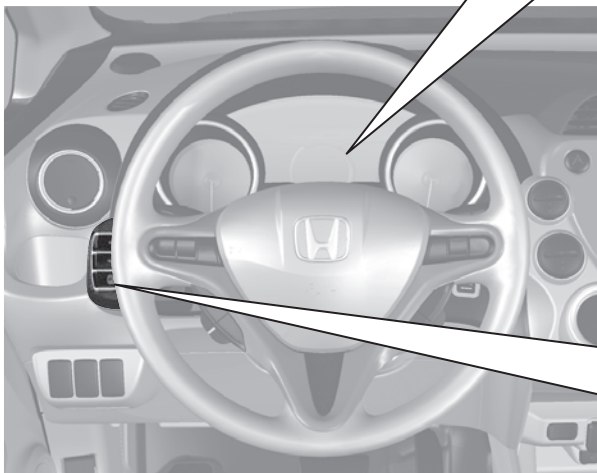

## SPORT Mode

Increases motor performance. Suitable for driving in hills or curves on a mountain, or driving in a suburb.

## NORMAL Mode

Balances driving performance and energy economy. Best for most driving situations.

## ECON Mode

Maximizes energy economy.

# Safe Driving P. 29

## Airbags P. 41

- Your vehicle is fitted with airbags to help protect you and your passengers during a moderate-to-severe collision.

## Child Safety P. 56

- All children 12 and younger should be seated in the rear seat.
- Smaller children should be properly restrained in a forward-facing child seat.
- Infants must be properly restrained in a rear-facing child seat.

## Seat Belts P. 34

- Fasten your seat belt and sit upright well back in the seat.
- Check that your passengers are wearing their seat belts correctly.

## Before Driving Checklist P. 144

- Before driving, check that the front seats, head restraints, steering wheel, and mirrors have been properly adjusted.

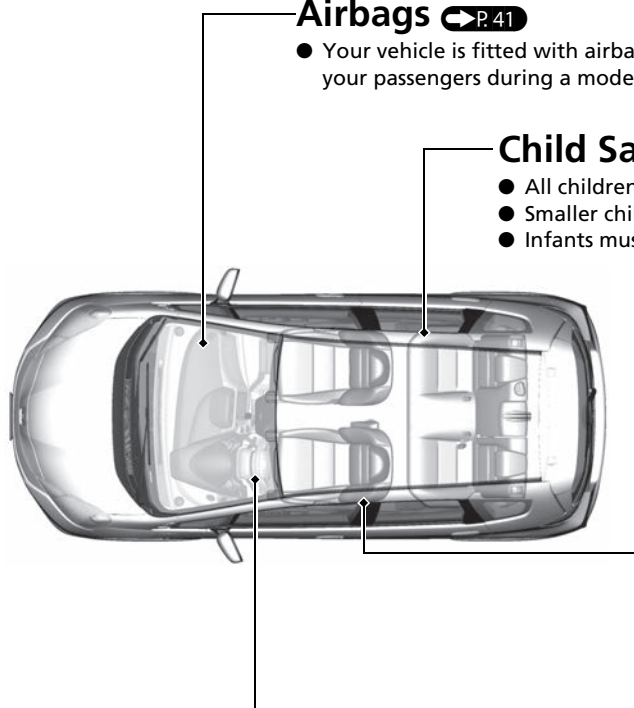



Fasten your lap belt as low as possible.











# Instrument Panel P.69

## Gauges P.81 / Multi-Information Display P.83 / System Indicators P.70

### Lights Reminders







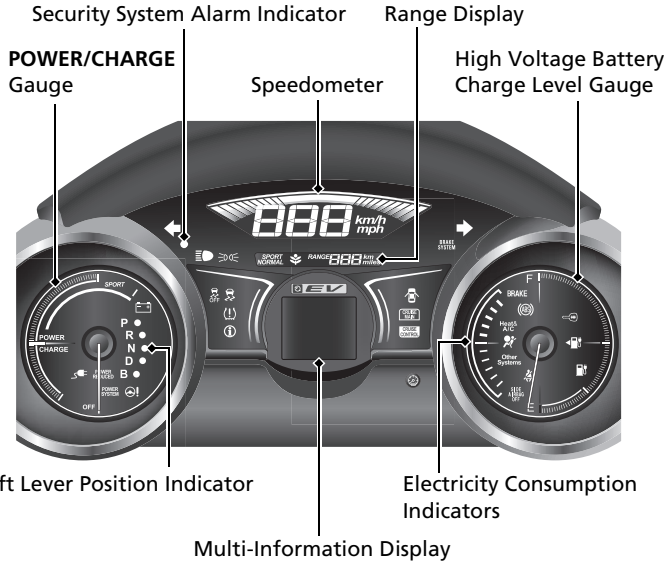

-  High Beam Indicator
-  Lights On Indicator

### System Indicators



-  12 Volt Charging System Indicator
-  Charge Connector Indicator
-  **POWER REDUCED** Indicator
-  **POWER SYSTEM** Indicator
-  Electric Power Steering (EPS) System Indicator
-  Vehicle Stability Assist (VSA®) System Indicator
-  VSA® OFF Indicator
-  Low Tire Pressure/TPMS Indicator
-  System Message Indicator





### System Indicators

-  Turn Signal and Hazard Warning Indicators
-  **BRAKE SYSTEM** Brake System Indicator (Amber)
-  **BRAKE** Brake Warning Indicator (Red)
-  **(ABS)** Anti-lock Brake System (ABS) Indicator
-  Immobilizer System Indicator
-  Supplemental Restraint System Indicator
-  Low Charge Indicator
-  Seat Belt Reminder Indicator
-  **SIDE AIRBAG OFF** Side Airbag Off Indicator

### System Indicators

-  **SPORT** SPORT Mode Indicator
-  **NORMAL** NORMAL Mode Indicator
-  **ECON** Mode Indicator

### System Indicators

-  Door and Tailgate Open Indicator
-  **CRUISE MAIN** Indicator
-  **CRUISE CONTROL** Indicator

# Controls P.97

## Clock

The navigation system receives signals from GPS satellites, updating the clock automatically.

## Audio System P.142

 See the Navigation System Manual

## Turn Signals P.112

Turn Signal Control Lever

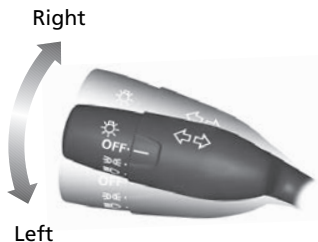

## Lights P.112

Light Control Switches

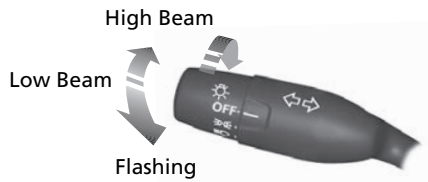

## Wipers and Washers

 P.114

Wiper/Washer Control Lever

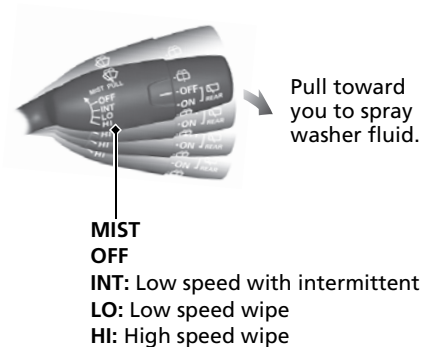

## Steering Wheel P.118

- To adjust, pull the adjustment lever towards you, adjust to the desired position, then lock the lever back in place.

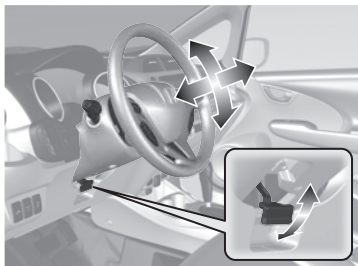

## Tailgate P.105

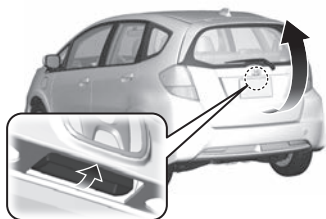

- To open the tailgate, pull the tailgate open handle, and lift up.

## Power Door Mirrors

### P.119

- With the power switch in ON , move the selector switch to **L** or **R**.
- Push the appropriate edge of the adjustment switch to adjust the mirror.

Selector Switch

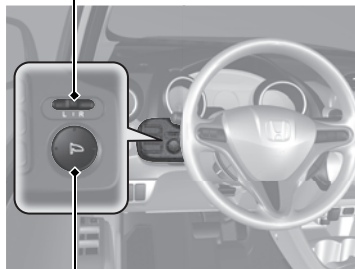

Adjustment Switch

## Power Windows P.109

- With the power switch in ON , open and close the power windows.
- If the power window lock button is in the off position, each passenger's window can be opened and closed with its own switch.
- If the power window lock button is in the on position, each passenger's window switch is disabled.

Power Window Lock Button



Window Switch

## Climate Control System P.133

- Press the **AUTO** button to activate the climate control system.
- Press the  button to defrost the windshield.
- Press the **ON/OFF** button to turn the system on or off.
- The climate control system is voice operable. See the navigation system manual for complete details.

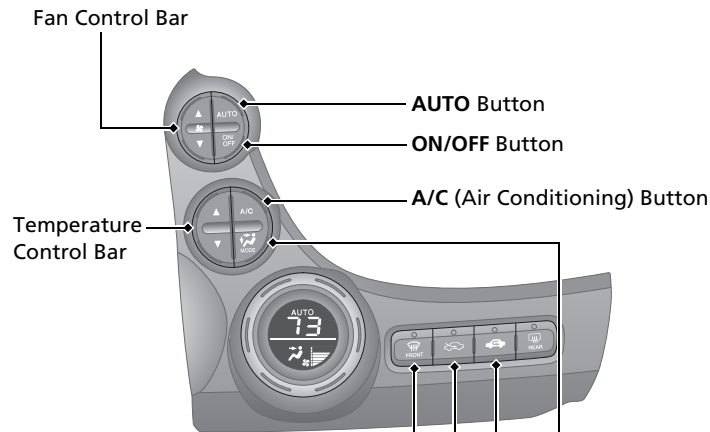





 (Windshield Defroster) Button

 (Fresh Air) Button

 (Recirculation) Button

### MODE Control Button

-  Air flows from dashboard vents.
-  Air flows from floor and dashboard vents.
-  Air flows from floor vents.
-  Air flows from floor and windshield defroster vents.

## Interactive Remote P.136

- Charging the High Voltage battery
  1. Make sure the charge connector cable is plugged in.
  2. Press the power button.
  3. Press and hold the Charge button.
    - ▶ The beeper sounds once.
- Turning on the climate control system
  1. Press the power button.
  2. Press and hold the **Climate** button.
    - ▶ The beeper sounds once.



## Smartphone App Visit [owners.honda.com/apps](https://owners.honda.com/apps)

Downloading the smartphone app for the telematics allows for remotely checking your vehicle's latest status, such as the charge level, and the interior temperature, starting the vehicle charge, and turning on the climate control system.

The table below shows what you can using the interactive remote, or smartphone app.

Features	Items	Interactive Remote	Smartphone App
Receiving the vehicle information	High Voltage battery charge level	✓	✓
	Interior temperature	✓	✓
	Charging status	✓	✓
	Climate control system status	✓	✓
	Detailed status		✓
Charging the vehicle remotely	Start/Stop	✓	✓
Turning on and off the climate control system remotely	Start/Stop	✓	✓
Setting the charging timer*1	Setting		✓
Climate control timer setting at full charge	Setting		✓

\*1: Charge timer can also be set using the multi-information display.  P. 182





# Driving P.143

## Transmission P.152

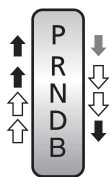
- Shift to **P** and depress the brake pedal when turning on the power.

### Shifting



-  Depress the brake pedal and press the release button to move out of **P**.
-   Press the release button to move the shift lever.
-   Move the shift lever without pressing the release button.



- P** **Park**  
Used when parking or turning the power on or off.
- R** **Reverse**  
Used when reversing.
- N** **Neutral**
- D** **Drive**  
Used for normal driving.
- B** **Drive (B)**
  - Used when driving down a long hill
  - Used to increase regenerative braking.

## VSA® OFF Button P.161

- The vehicle stability assist (VSA®) system helps stabilize the vehicle during cornering, and helps maintain traction while accelerating on loose or slippery road surfaces.
- VSA® comes on automatically every time you turn on the power system.
- To turn VSA® on or off, press and hold the button until you hear a beep.

## Cruise Control P.157

- Cruise control allows you to maintain a set speed without keeping your foot on the accelerator pedal.
- To use cruise control, press the **CRUISE** button, then press **DECEL/SET** once you have achieved the desired speed (above 25 mph or 40 km/h).

## Tire Pressure Monitoring System (TPMS) P.162

- TPMS monitors tire pressure.
- TPMS is turned on automatically every time you turn on the power system.

# Maintenance P.187

## Under the Hood P.195

- Check coolants and windshield washer fluid. Add when necessary.
- Check brake fluid.
- Check the 12 volt battery condition monthly.

- 1** Pull the hood release handle under the corner of the dashboard.

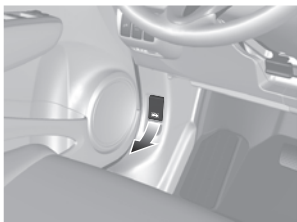

- 2** Locate the hood latch lever, pull the lever up, and lift up the hood.



- 3** When finished, close the hood and make sure it is firmly locked in place.

## Wiper Blades P.207

- Replace blades if they leave streaks across the windshield.

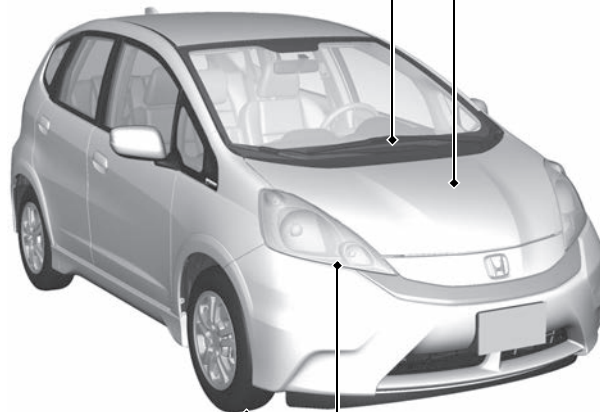

## Tires P.211

- Inspect tires and wheels regularly.
- Check tire pressures regularly.
- Install snow tires for winter driving.

## Lights P.202

- Inspect all lights regularly.



# Handling the Unexpected P.227

## Flat Tire P.229

- Park in a safe location and repair the flat tire using the tire repair kit in the cargo area.



## Power System Won't Start P.237

- If the 12 volt battery is dead, jump start using a booster battery.

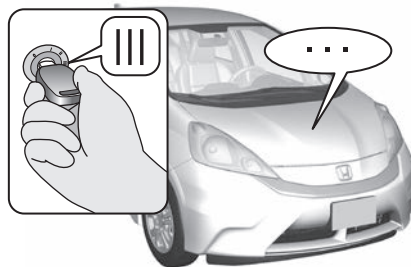

## Indicators Come On P.242

- Identify the indicator and consult the owner's manual.

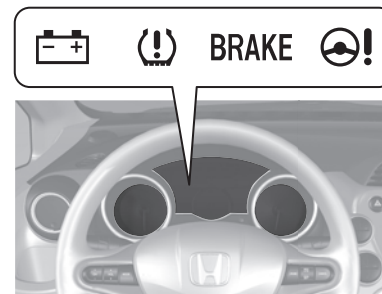

## Blown Fuse P.245

- Check for a blown fuse if an electrical device does not operate.

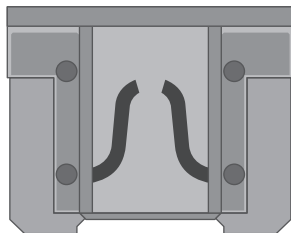

## Emergency Towing P.250

- Call a professional towing service if you need to tow your vehicle.



# What to Do If

**Q** The power switch does not turn from **0** to **I**. Why?

**A**

- The steering wheel may be locked.
- Try to turn the steering wheel left and right while turning the key.



**Q** The power switch does not turn from **I** to **0** and I cannot remove the key. Why?

**A** The shift lever should be moved to **P**.



**Q** Why does the brake pedal pulsate slightly when applying the brakes?

**A** This can occur when the ABS activates, and does not indicate a problem. Apply firm, steady pressure on the brake pedal. Never pump the brake pedal.

**Q** The rear door cannot be opened from inside the vehicle. Why?

**A** Check if the childproof lock is in the lock position. If so, open the rear door with the outside door handle. To cancel this function, push the lever to the unlock position.

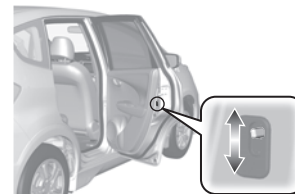

---

**Q** Why do the doors lock after I unlocked the doors using a remote transmitter?

**A** If you do not open the doors within 30 seconds, the doors are relocked automatically for security.

---

**Q** Why does the beeper sound when I open the driver's door?

**A** The beeper sounds when:

- The key is left in the power switch.
- The exterior lights are left on.

---

**Q** Why does the beeper sound when I start driving?

**A** The beeper sounds when:

- Driver and/or front passenger are not wearing their seat belts.
- The parking brake lever is not fully released.

---

**Q** Why do I hear a screeching sound when I apply the brake pedal?

**A** The brake pads may need to be replaced. Have your vehicle inspected by an authorized Honda Fit EV dealer.

---

## California Proposition 65 Warning

**WARNING:** This product contains or emits chemicals known to the state of California to cause cancer and birth defects or other reproductive harm.

### Event Data Recorders

**This vehicle is equipped with an event data recorder (EDR).**

The main purpose of an EDR is to record, in certain crash or near crash-like situations, such as an air bag deployment or hitting a road obstacle, data that will assist in understanding how a vehicle's systems performed. **The EDR is designed to record data related to vehicle dynamics and safety systems for a short period of time, typically 30 seconds or less. The EDR in this vehicle is designed to record such data as:**

- **How various systems in your vehicle were operating;**
- **Whether or not the driver and passenger safety belts were buckled/fastened;**
- **How far (if at all) the driver was depressing the accelerator and/or brake pedal; and,**
- **How fast the vehicle was traveling.**

These data can help provide a better understanding of the circumstances in which crashes and injuries occur. NOTE: EDR data are recorded by your vehicle only if a non-trivial crash situation occurs; no data are recorded by the EDR under normal driving conditions and no personal data (e.g., name, gender, age, and crash location) are recorded. However, other parties, such as law enforcement, could combine the EDR data with the type of personally identifying data routinely acquired during a crash investigation.

To read data recorded by an EDR, special equipment is required, and access to the vehicle or the EDR is needed. In addition to the vehicle manufacturer, other parties, such as law enforcement, that have the special equipment, can read the information if they have access to the vehicle or the EDR.

The data belongs to the vehicle owner and may not be accessed by anyone else except as legally required or with the permission of the vehicle owner.

### Service Diagnostic Recorders

This vehicle is equipped with service-related devices that record information about powertrain performance. The data can be used to verify emissions law requirements and/or help technicians diagnose and solve service problems. It may also be combined with data from other sources for research purposes, but it remains confidential.

### Vehicle Telematics and High-Voltage Battery Monitoring System

**This vehicle is equipped with monitoring systems that record vehicle specific (VIN based) information about how the vehicle is being driven (e.g., speed, acceleration, mileage, driving time), vehicle location (latitude, longitude, time), and battery condition while the system is powered on, and then automatically transmits this data to Honda every few minutes. The data transmission system is designed to be secure and is only to be used by Honda.** Honda may use the data to help diagnose problems that may arise with the vehicle and may also combine it with other data for research purposes.

Regardless of its use, Honda will keep the data confidential and will not permit others to access it unless such access is legally required.

### California Perchlorate Contamination Prevention Act

The airbags, seat belt tensioners, and CR type batteries in this vehicle may contain perchlorate materials - special handling may apply. See [www.dtsc.ca.gov/hazardouswaste/perchlorate/](http://www.dtsc.ca.gov/hazardouswaste/perchlorate/)

As you read this manual, you will find information that is preceded by a **NOTICE** symbol. This information is intended to help you avoid damage to your vehicle, other property, or the environment.

## A Few Words About Safety

Your safety, and the safety of others, is very important. And operating this vehicle safely is an important responsibility.

To help you make informed decisions about safety, we have provided operating procedures and other information on labels and in this manual. This information alerts you to potential hazards that could hurt you or others.

Of course, it is not practical or possible to warn you about all the hazards associated with operating or maintaining your vehicle. You must use your own good judgement.

You will find this important safety information in a variety of forms, including:

- **Safety Labels** - on the vehicle.
- **Safety Messages** - preceded by a safety alert symbol  and one of three signal words: **DANGER**, **WARNING**, or **CAUTION**. These signal words mean:

 **DANGER**

You **WILL** be KILLED or SERIOUSLY HURT if you don't follow instructions.

 **WARNING**

You **CAN** be KILLED or SERIOUSLY HURT if you don't follow instructions.

 **CAUTION**

You **CAN** be HURT if you don't follow instructions.

- **Safety Headings** - such as Important Safety Precautions.
- **Safety Section** - such as Safe Driving.
- **Instructions** - how to use this vehicle correctly and safely.

This entire book is filled with important safety information - please read it carefully.

# Safe Driving

You can find many safety recommendations throughout this chapter, and throughout this manual.

## **For Safe Driving**

Important Safety Precautions .....	30
Your Vehicle's Safety Features.....	32

## **Seat Belts**

About Your Seat Belts.....	34
Fastening a Seat Belt.....	37
Seat Belt Inspection.....	40

## **Airbags**

Airbag System Components.....	41
Types of Airbags .....	44
Front Airbags (SRS) .....	44
Side Airbags.....	48

Side Curtain Airbags .....	51
Airbag System Indicators.....	52
Airbag Care .....	55

## **Child Safety**

Protecting Child Passengers .....	56
Safety of Infants and Small Children ..	58
Safety of Larger Children .....	66

## **Safety Labels**

Label Locations .....	68
-----------------------	----

The following pages explain your vehicle's safety features and how to use them properly. The safety precautions below are ones that we consider to be among the most important.

## Important Safety Precautions

### ■ Always wear your seat belt

A seat belt is your best protection in all types of collisions. Airbags are designed to supplement seat belts, not replace them. So even though your vehicle is equipped with airbags, make sure you and your passengers always wear your seat belts, and wear them properly.

### ■ Restrain all children

Children age 12 and under should ride properly restrained in a back seat, not the front seat. Infants and small children should be restrained in a child seat. Larger children should use a booster seat and a lap/shoulder seat belt until they can use the belt properly without a booster seat.

### ■ Be aware of airbag hazards

While airbags can save lives, they can cause serious or fatal injuries to occupants who sit too close to them, or are not properly restrained. Infants, young children, and short adults are at the greatest risk. Be sure to follow all instructions and warnings in this manual.

### ■ Don't drink and drive

Alcohol and driving don't mix. Even one drink can reduce your ability to respond to changing conditions, and your reaction time gets worse with every additional drink. So don't drink and drive, and don't let your friends drink and drive, either.

### ⓘ Important Safety Precautions

Some states, provinces and territories prohibit the use of cell phones other than hands-free devices by the driver while driving.

**■ Pay appropriate attention to the task of driving safely**

Engaging in cell phone conversation or other activities that keep you from paying close attention to the road, other vehicles, and pedestrians could lead to a crash. Remember, situations can change quickly, and only you can decide when it is safe to divert some attention away from driving.

**■ Control your speed**

Excessive speed is a major factor in crash injuries and deaths. Generally, the higher the speed, the greater the risk, but serious injuries can also occur at lower speeds. Never drive faster than is safe for current conditions, regardless of the maximum speed posted.

**■ Keep your vehicle in safe condition**

Having a tire blowout or a mechanical failure can be extremely hazardous. To reduce the possibility of such problems, check your tire pressures and condition frequently, and perform all regularly scheduled maintenance.

**■ Handle high-voltage with care**

Familiarize yourself with the charging instructions and warnings supplied in this manual and on the quick reference card. If using a public charger, also observe the charging station manufacturer's instructions.



## Your Vehicle's Safety Features

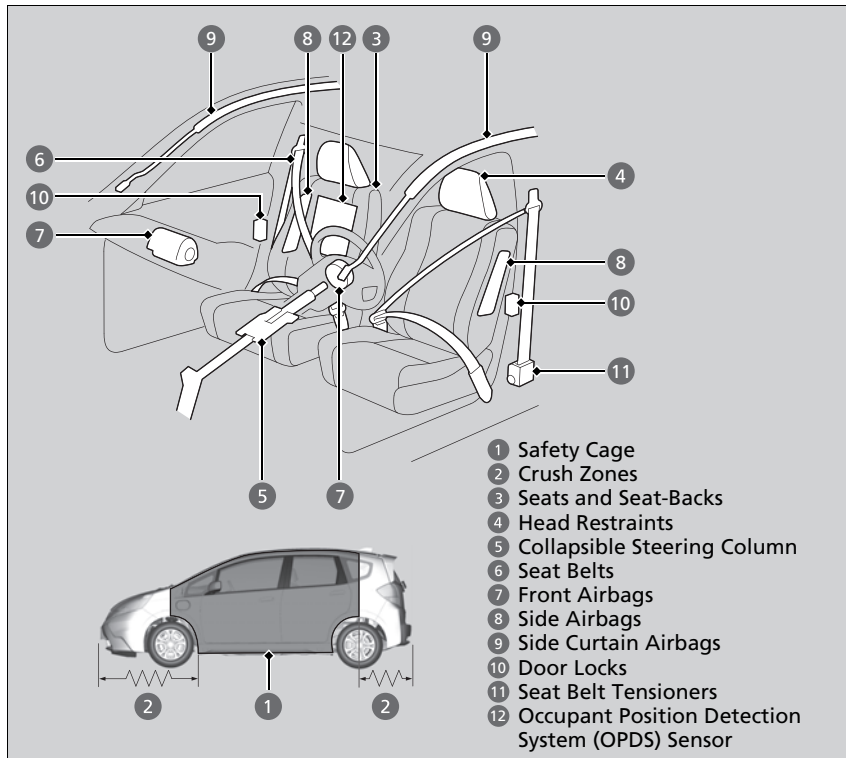

The following checklist will help you take an active role in protecting yourself and your passengers.

### ►► Your Vehicle's Safety Features

Your vehicle is equipped with many features that work together to help protect you and your passengers during a crash.

Some features do not require any action on your part. These include a strong steel framework that forms a safety cage around the passenger compartment, front and rear crush zones, a collapsible steering column, and tensioners that tighten the front seat belts in a sufficient crash.

However, you and your passengers cannot take full advantage of these features unless you remain seated in the correct position and always wear your seat belts. In fact, some safety features can contribute to injuries if they are not used properly.

## Safety Checklist

For the safety of you and your passengers, make a habit of checking these items each time before you drive.

Check if the charging cable is connected to the vehicle and disconnect it if it is. The vehicle will not operate with the cable connected.

- After everyone has entered the vehicle, be sure all doors and the tailgate are closed and locked. Locking the doors and the tailgate helps prevent an occupant from being ejected and an outsider from unexpectedly opening a door or the tailgate.

➤ **Locking/Unlocking the Doors from the Inside** P. 102

- Adjust your seat to a position suitable for driving. Be sure the front seats are adjusted as far to the rear as possible while allowing the driver to control the vehicle. Sitting too close to a front airbag can result in serious or fatal injury in a crash.

➤ **Adjusting the Seats** P. 120

- Adjust head restraints to the proper position. Head restraints are most effective when the center of the head restraint aligns with the center of your head. Taller persons should adjust their head restraint to the highest position.

➤ **Adjusting the Head Restraints** P. 122

- Always wear your seat belt, and make sure you wear it properly. Confirm that any passengers are properly belted as well.

➤ **Fastening a Seat Belt** P. 37

- Protect children by using seat belts or child seats according to a child's age, height and weight.

➤ **Child Safety** P. 56

### ➤ Safety Checklist

If the door and tailgate open indicator is on, a door and/or the tailgate is not completely closed. Close all doors and the tailgate tightly until the indicator goes off.

➤ **Door and Tailgate Open Indicator** P. 75



## About Your Seat Belts

Seat belts are the single most effective safety device because they keep you connected to the vehicle so that you can take advantage of many built-in safety features. They also help keep you from being thrown against the inside of the vehicle, against other passengers, or out of the vehicle. When worn properly, seat belts also keep your body properly positioned in a crash so that you can take full advantage of the additional protection provided by the airbags.

In addition, seat belts help protect you in almost every type of crash, including:

- frontal impacts
- side impacts
- rear impacts
- rollovers

### ■ Lap/shoulder seat belts

All five seating positions are equipped with lap/shoulder seat belts with emergency locking retractors. In normal driving the retractor lets you move freely while keeping some tension on the belt. During a collision or sudden stop the retractor locks to restrain your body. The front passenger's and rear seat belts also have a lockable retractor for use with child seats.

➤ **Installing a Child Seat with a Lap/Shoulder Seat Belt** P. 63

### ➤ About Your Seat Belts

## **WARNING**

**Not wearing a seat belt properly increases the chance of serious injury or death in a crash, even though your vehicle has airbags.**

**Be sure you and your passengers always wear seat belts and wear them properly.**

Seat belts cannot completely protect you in every crash. But in most cases, seat belts can reduce your risk of serious injury.

Most states and all Canadian provinces and territories require you to wear seat belts.

## ■ Proper use of seat belts

Follow these guidelines for proper use:

- All occupants should sit upright, well back in the seat, and remain in that position for the duration of the trip. Slouching and leaning reduces the effectiveness of the belt and can increase the chance of serious injury in a crash.
- Never place the shoulder part of a lap/shoulder seat belt under your arm or behind your back. This could cause very serious injuries in a crash.
- Two people should never use the same seat belt. If they do, they could be very seriously injured in a crash.
- Do not put any accessories on the seat belts. Devices intended to improve comfort or reposition the shoulder part of a seat belt can reduce the protective capability and increase the chance of serious injury in a crash.

## ■ Seat Belt Reminder



Your vehicle monitors front seat belt use. If the power switch is turned to ON **II** before the driver's seat belt is fastened, a beeper will sound and the indicator will blink. If the driver does not fasten the belt before the beeper stops, the indicator will remain on.

The beeper will also periodically sound and the indicator will blink while driving until the driver's and front passenger's seat belts are fastened.

## ⌘ About Your Seat Belts

If a rear seat passenger moves around and extends the seat belt, the lockable retractor may activate. If this happens, release the retractor by unfastening the seat belt and allow the belt to retract completely. Then refasten the belt.

## ⌘ Seat Belt Reminder

The indicator will also come on if a front passenger does not fasten their seat belt within six seconds after the power switch is turned to ON **II**. When no one is sitting in the front passenger's seat, or a child or small adult is riding there, the indicator will not come on. This is because the weight sensors in the seat cannot detect their presence.

## ■ Automatic Seat Belt Tensioners

The front seats are equipped with automatic seat belt tensioners to enhance safety.

The tensioners automatically tighten the front seat belts during a moderate-to-severe frontal collision, sometimes even if the collision is not severe enough to inflate the front airbags.

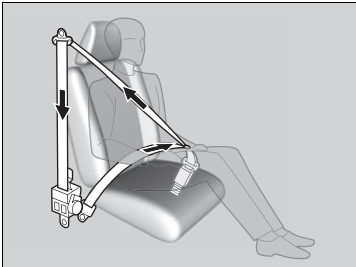

## ▶▶ Automatic Seat Belt Tensioners

The seat belt tensioners can only operate once. If a tensioner is activated, the SRS indicator will come on. Have an authorized Honda Fit EV dealer replace the tensioner and thoroughly inspect the seat belt system as it may not offer protection in a subsequent crash.

## Fastening a Seat Belt

After adjusting a front seat to the proper position, and while sitting upright and well back in the seat:

🔧 **Adjusting the Seats** P. 120

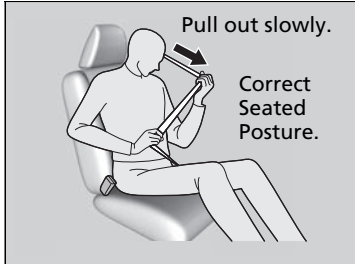

1. Pull the seat belt out slowly.

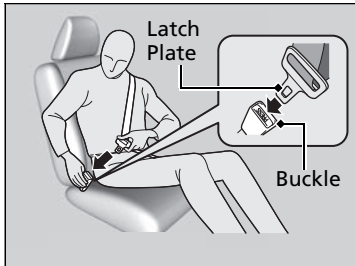

2. Insert the latch plate into the buckle, then tug on the belt to make sure the buckle is secure.

▶ Make sure that the belt is not twisted or caught on anything.

### 🔧 Fastening a Seat Belt

No one should sit in a seat with an inoperative seat belt or one that does not appear to be working correctly. Using a seat belt that is not working properly may not protect the occupant in a crash. Have an authorized Honda Fit EV dealer check the belt as soon as possible.

Never insert any foreign objects into the buckle or retractor mechanism.



3. Position the lap part of the belt as low as possible across your hips, then pull up on the shoulder part of the belt so the lap part fits snugly. This lets your strong pelvic bones take the force of a crash and reduces the chance of internal injuries.
4. If necessary, pull up on the belt again to remove any slack, then check that the belt rests across the center of your chest and over your shoulder. This spreads the forces of a crash over the strongest bones in your upper body.

### Adjusting the Shoulder Anchor

The front seats have adjustable shoulder anchors to accommodate taller and shorter occupants.

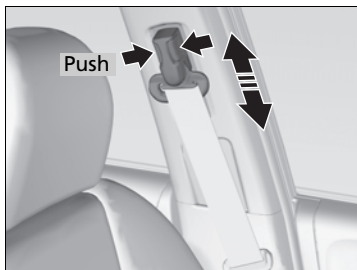

1. Move the anchor up and down while holding the release button.
2. Position the anchor so that the belt rests across the center of your chest and over your shoulder.

### Fastening a Seat Belt

#### **WARNING**

Improperly positioning the seat belts can cause serious injury or death in a crash.

**Make sure all seat belts are properly positioned before driving.**

To release the belt, push the red **PRESS** button then guide the belt by hand until it has retracted completely.

When exiting the vehicle, be sure the belt is out of the way and will not get caught by closing the door.

### Adjusting the Shoulder Anchor

The shoulder anchor height can be adjusted to four levels. If the belt contacts your neck, lower the height one level at a time.

After an adjustment, make sure that the shoulder anchor position is secure.

## Advice for Pregnant Women

If you are pregnant, the best way to protect yourself and your unborn child when driving or riding in a vehicle is to always wear a seat belt and keep the lap part of the belt as low as possible across the hips.

Wear the shoulder belt across the chest avoiding the abdomen.



Wear the lap part of the belt as low as possible across the hips.

## Advice for Pregnant Women

Each time you have a checkup, ask your doctor if it is okay for you to drive.

To reduce the risk of injuries to both you and your unborn child that can be caused by an inflating front airbag:

- When driving, sit upright and adjust the seat as far back as possible while allowing full control of the vehicle.
- When sitting in the front passenger's seat, adjust the seat as far back as possible.



## Seat Belt Inspection

Regularly check the condition of your seat belts as follows:

- Pull each belt out fully, and look for frays, cuts, burns, and wear.
- Check that the latches work smoothly and the belts retract easily.
  - ▶ If a belt does not retract easily, cleaning the belt may correct the problem. Only use a mild soap and warm water. Do not use bleach or cleaning solvents. Make sure the belt is completely dry before allowing it to retract.

Any belt that is not in good condition or working properly will not provide proper protection and should be replaced as soon as possible.

A belt that has been worn during a crash may not provide the same level of protection in a subsequent crash. Have your seat belts inspected by an authorized Honda Fit EV dealer after any collision.

### ▶▶ Seat Belt Inspection

#### **WARNING**

**Not checking or maintaining seat belts can result in serious injury or death if the seat belts do not work properly when needed.**

**Check your seat belts regularly and have any problem corrected as soon as possible.**

## Airbag System Components

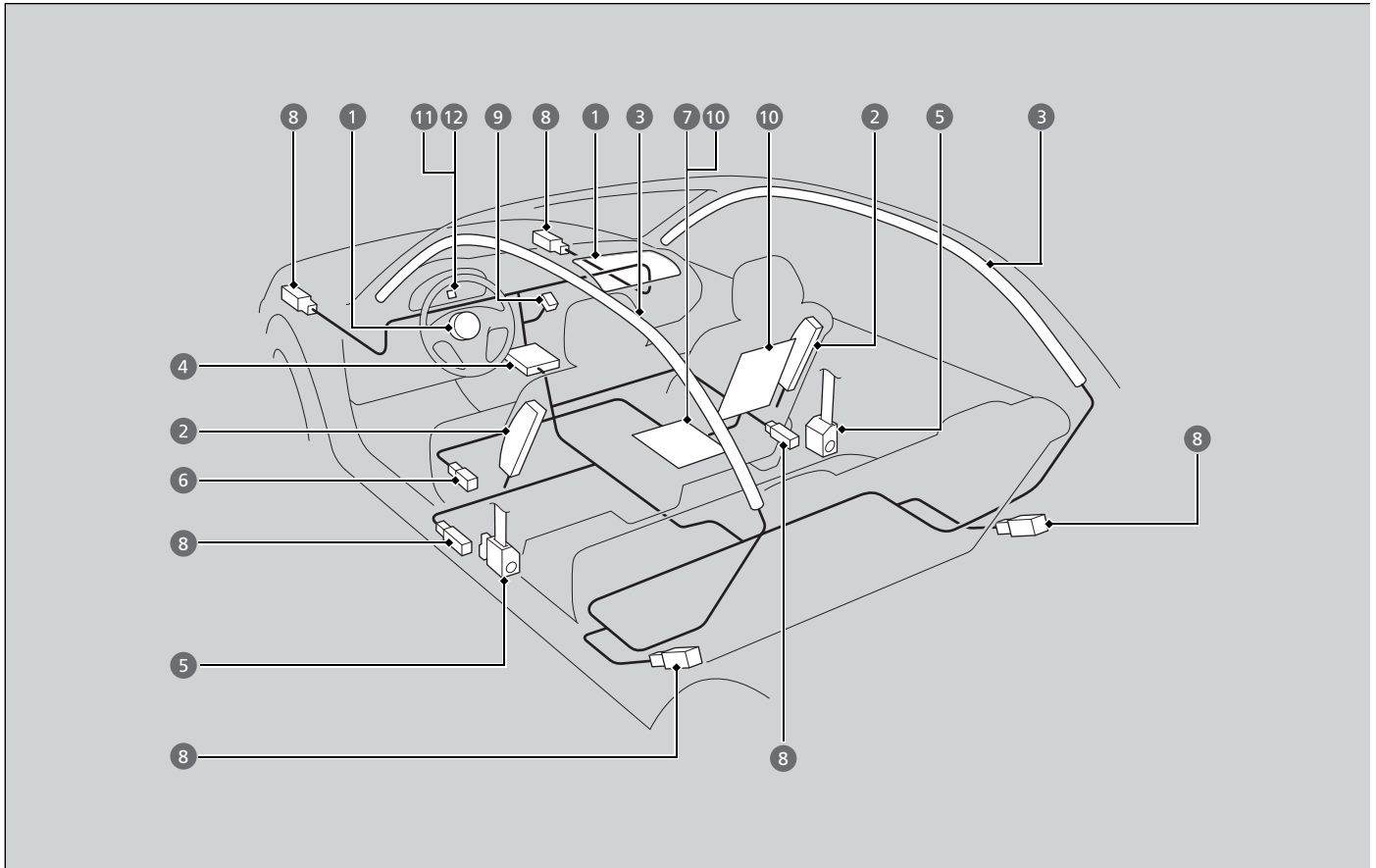

Continued

The front, front side, and side curtain airbags are deployed according to the direction and severity of impact. The airbag system includes:

- 1 Two SRS (Supplemental Restraint System) front airbags. The driver's airbag is stored in the center of the steering wheel; the front passenger's airbag is stored in the dashboard. Both are marked **SRS AIRBAG**.
- 2 Two side airbags, one for the driver and one for a front passenger. The airbags are stored in the outer edges of the seat-backs. Both are marked **SIDE AIRBAG**.
- 3 Two side curtain airbags, one for each side of the vehicle. The airbags are stored in the ceiling, above the side windows. The front and rear pillars are marked **SIDE CURTAIN AIRBAG**.
- 4 An electronic control unit that continually monitors and records information about the sensors, the airbag activators, the seat belt tensioners, and driver and front passenger seat belt use when the power switch is in ON **II**.
- 5 Automatic front seat belt tensioners. The driver's and front passenger's seat belts incorporate sensors that detect whether or not they are fastened.
- 6 A driver's seat position sensor. If the seat is too far forward, the airbag will inflate with less force.
- 7 Weight sensors in the front passenger's seat. The front passenger's airbag will be turned off if the weight on the seat is 65 lbs (29 kg) or less (the weight of an infant or small child).
- 8 Impact sensors that can detect a moderate to severe front or side collision.
- 9 An indicator on the dashboard that alerts you that the front passenger's front airbag has been turned off.
- 10 Sensors that can detect if a child or small statured adult is in the deployment path of the front passenger's side airbag.
- 11 An indicator on the instrument panel that alerts you to a possible problem with your airbag system or seat belt tensioners.
- 12 An indicator on the instrument panel that alerts you that the front passenger's side airbag has been turned off.

## Important facts about your airbags

Airbags can pose serious hazards. To do their job, airbags must inflate with tremendous force. So, while airbags help save lives, they can cause burns, bruises, and other minor injuries, and sometimes even fatal ones if occupants are not wearing their seat belts properly and sitting correctly.

**What you should do:** Always wear your seat belt properly, and sit upright and as far back from the steering wheel as possible while allowing full control of the vehicle. A front passenger should move their seat as far back from the dashboard as possible.

Remember, however, that no safety system can prevent all injuries or deaths that can occur in a severe crash, even when seat belts are properly worn and the airbags deploy.

**Do not place hard or sharp objects between yourself and a front airbag.**

Carrying hard or sharp objects on your lap, or driving with a pipe or other sharp object in your mouth, can result in injuries if your front airbag inflates.

**Do not attach or place objects on the front airbag covers.** Objects on the covers marked **SRS AIRBAG** could interfere with the proper operation of the airbags or be propelled inside the vehicle and hurt someone if the airbags inflate.

## Important facts about your airbags

Do not attempt to deactivate your airbags. Together, airbags and seat belts provide the best protection.

When driving, keep hands and arms out of the deployment path of the front airbag by holding each side of the steering wheel. Do not cross an arm over the airbag cover.

## Types of Airbags

Your vehicle is equipped with three types of airbags:

- **Front airbags:** Airbags in front of the driver's and front passenger's seats.
- **Side airbags:** Airbags in the driver's and front passenger's seat-backs.
- **Side curtain airbags:** Airbags above the side windows.

Each is discussed in the following pages.

### Front Airbags (SRS)

The front SRS airbags inflate in a moderate to severe frontal collision to help protect the head and chest of the driver and/or front passenger.

**SRS** (Supplemental Restraint System) indicates that the airbags are designed to supplement seat belts, not replace them. Seat belts are the occupant's primary restraint system.

#### Housing Locations

The front airbags are housed in the center of the steering wheel for the driver, and in the dashboard for the front passenger. Both airbags are marked **SRS AIRBAG**.

#### Types of Airbags

The airbags can inflate whenever the power switch is in ON **II**.

#### Front Airbags (SRS)

##### Dual-Stage, Multiple-Threshold Front Airbags (SRS)

Your vehicle is equipped with dual-stage, multiple-threshold front airbags (SRS).

During a frontal crash severe enough to cause one or both front airbags to deploy, the airbags can inflate at different rates, depending on the severity of the crash, whether or not the seat belts are latched, and/or other factors. Frontal airbags are designed to supplement the seat belts to help reduce the likelihood of head and chest injuries in frontal crashes.

## ■ Operation

Front airbags are designed to inflate during moderate-to-severe frontal collisions. When the vehicle decelerates suddenly, the sensors send information to the control unit which signals one or both front airbags to inflate.

A frontal collision can be either head-on or angled between two vehicles, or when a vehicle crashes into a stationary object, such as a concrete wall.

## ■ How the Front Airbags Work

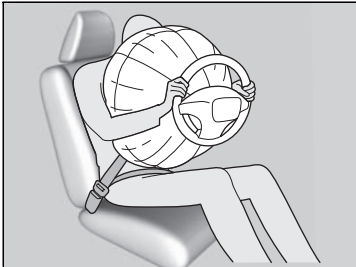

While your seat belt restrains your torso, the front airbag provides supplemental protection for your head and chest.

The front airbags deflate immediately so that they won't interfere with the driver's visibility or the ability to steer or operate other controls.

The total time for inflation and deflation is so fast that most occupants are not aware that the airbags deployed until they see them lying in front of them.

### ☒ How the Front Airbags Work

After a front airbag inflates in a crash, you may see what looks like smoke. This is actually powder from the airbag's surface. Although the powder is not harmful, people with respiratory problems may experience some temporary discomfort. If this occurs, get out of the vehicle as soon as it is safe to do so.

Although the driver's and front passenger's airbags normally inflate within a split second of each other, it is possible for only one airbag to deploy. This can happen if the severity of a collision is at the margin, or threshold, that determines whether or not the airbags will deploy. In such cases, the seat belt will provide sufficient protection, and the supplemental protection offered by the airbag would be minimal.

### ■ When front airbags should not deploy

**Minor frontal crashes:** Front airbags were designed to supplement seat belts and help save lives, not to prevent minor scrapes, or even broken bones that might occur during a less than moderate-to-severe frontal crash.

**Side impacts:** Front airbags can provide protection when a sudden deceleration causes a driver or front passenger to move towards the front of the vehicle. Side airbags and side curtain airbags have been specifically designed to help reduce the severity of injuries that can occur during a moderate-to-severe side impact which can cause the driver or passenger to move towards the side of the vehicle.

**Rear impacts:** Head restraints and seat belts are your best protection during a rear impact. Front airbags cannot provide any significant protection and are not designed to deploy in such collisions.

**Rollovers:** Seat belts and, in vehicles equipped with a rollover sensor, side airbags and side curtain airbags offer the best protection in a rollover. Because front airbags could provide little if any protection, they are not designed to deploy during a rollover.

### ■ When front airbags deploy with little or no visible damage

Because the airbag system senses sudden deceleration, a strong impact to the vehicle framework or suspension might cause one or more of the airbags to deploy. Examples include running into a curb, the edge of a hole, or other low fixed object that causes a sudden deceleration in the vehicle chassis. Since the impact is underneath the vehicle, damage may not be readily apparent.

### ■ When front airbags may not deploy, even though exterior damage appears severe

Since crushable body parts absorb crash energy during an impact, the amount of visible damage does not always indicate proper airbag operation. In fact, some collisions can result in severe damage but no airbag deployment because the airbags would not have been needed or would not have provided protection even if they had deployed.

## Advanced Airbags

Your front airbags have advanced features to help reduce the likelihood of airbag related injuries to smaller occupants.

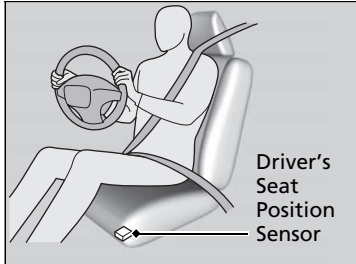

The driver's advanced front airbag system includes a seat position sensor.

If the seat is too far forward, the airbag inflates with less force, regardless of the severity of the impact.

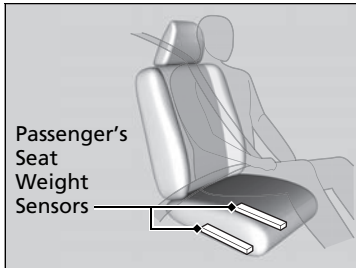

The passenger's advanced front airbag system has weight sensors.

Although Honda recommends against carrying an infant or small child in front, if the sensors detect the weight of a child (up to about 65 lbs or 29 kg), the system will automatically turn off the passenger's front airbag.

### Advanced Airbags

If there is a problem with the driver's seat position sensor, the SRS indicator will come on and the airbag will inflate with full (normal) force, regardless of the driver's seating position.

For both advanced front airbags to work properly:

- Do not spill any liquid on or under the seats.
- Do not put any object under the passenger's seat.
- Make sure any objects are positioned properly on the floor. Improperly positioned objects can interfere with the advanced airbag sensors.
- All occupants should sit upright and wear their seat belts properly.
- Do not place any cover over the passenger side dashboard.



## Side Airbags

The side airbags help protect the upper torso of the driver or a front passenger during a moderate-to-severe side impact.

### Housing Locations

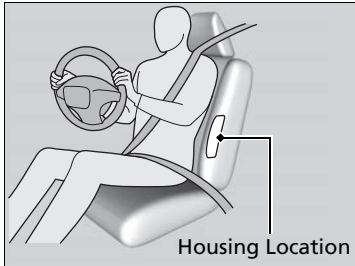

The side airbags are housed in the outside edge of the driver's and passenger's seat-backs.

Both are marked **SIDE AIRBAG**.

### Operation

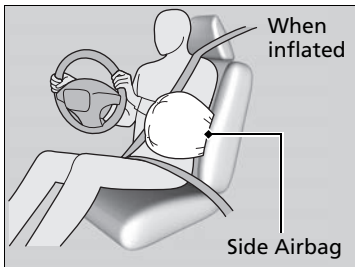

When the sensors detect a moderate-to-severe side impact, the control unit signals the side airbag on the impact side to immediately inflate.

### Side Airbags

Do not attach accessories on or near the side airbags. They can interfere with the proper operation of the airbags, or hurt someone if an airbag inflates.

If the impact is on the passenger side, the airbag deploys even if there is no passenger in the passenger seat.

Do not cover or replace the front seat-back covers without consulting an authorized Honda Fit EV dealer.

Improperly replacing or covering front seat-back covers can prevent your side airbags from properly deploying during a side impact.

**■ When a side airbag deploys with little or no visible damage**

Because the airbag systems senses sudden acceleration, a strong impact to the side of the vehicle's framework can cause a side airbag to deploy. In such cases, there may be little or no damage, but the side impact sensors detected a severe enough impact to deploy the airbag.

**■ When a side airbag may not deploy, even though visible damage appears severe**

It is possible for a side airbag to not deploy during an impact that results in apparently severe damage. This can occur when the point of impact was towards the far front or rear of the vehicle, or when the vehicle's crushable body parts absorbed most of the crash energy. In either case, the side airbag would not have been needed nor provided protection even if it had deployed.

## ■ Side Airbag Cutoff System

To reduce the likelihood that a front passenger may be injured by an inflating side airbag, the passenger side airbag is automatically turned off when:

- The height sensors detect a child or short-statured adult is seated in the front passenger seat.
- The position sensor detects that the front passenger is leaning into the deployment path of the side airbag.

When the side airbag cutoff system is activated, the side airbag off indicator comes on.

➤ **Side Airbag Off Indicator** P. 54

## ■ Side Airbag Off Indicator

If the side airbag off indicator comes on, have the passenger sit upright. A few seconds after the passenger is sitting properly, the side airbag will automatically be turned on, and the indicator will go off.

If the front passenger is a child, stop when it is safe to do so, and have the child sit properly restrained in a rear seat.

## ➤ Side Airbag Cutoff System

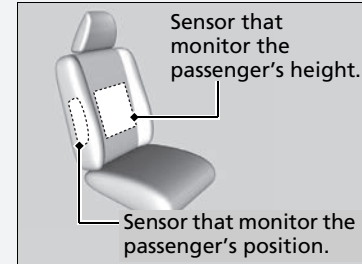

The sensors that monitor the front passenger's height and body position may not work if:

- The seat-back is wet
- The passenger is touching a metal or other electrical conductive object
- A seat cushion is on the seat
- The passenger is wearing excessively thick clothing

## Side Curtain Airbags

The side curtain airbags help protect the heads of the driver and passengers in outer seating positions during a moderate-to-severe side impact.

### ■ Housing Locations

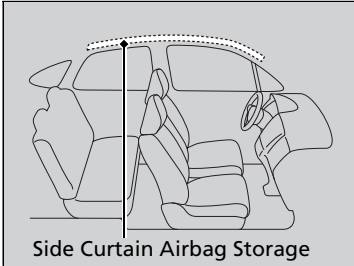

The side curtain airbags are located in the ceiling above the side windows on both sides of the vehicle.

### ■ Operation

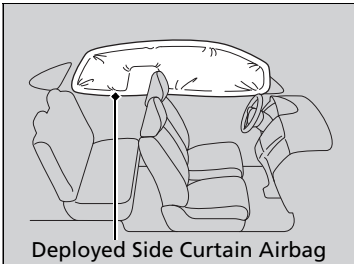

The side curtain airbag is designed to deploy in a moderate-to-severe side impact.

### ■ When side curtain airbags deploy in a frontal collision

One or both side curtain airbags may inflate in a moderate-to-severe angled frontal collision.

In this case, the side curtain airbags will deploy slightly after the front airbags.

### ▣ Side Curtain Airbags

The side curtain airbags are most effective when an occupant is wearing their seat belt properly and sitting upright, well back in their seat.

Do not attach any objects to the side windows or roof pillars as they can interfere with the proper operation of the side curtain airbags.

## Airbag System Indicators

If a problem occurs in the airbag system, the SRS indicator will come on.

### ■ SRS (Supplemental Restraint System) Indicator



#### ■ When the power switch is turned to ON



The indicator comes on for a few seconds, then goes off. This tells you the system is working properly.

If the indicator comes on at any other time, or does not come on at all, have the system checked by an authorized Honda Fit EV dealer as soon as possible. If you don't, your airbags and seat belt tensioners may not work properly when they are needed.

### ⚠ SRS (Supplemental Restraint System) Indicator

## ⚠ WARNING

Ignoring the SRS indicator can result in serious injury or death if the airbag systems or tensioners do not work properly.

Have your vehicle checked by a dealer as possible if the SRS indicator alerts you to a possible problem.

## ■ Passenger Airbag Off Indicator

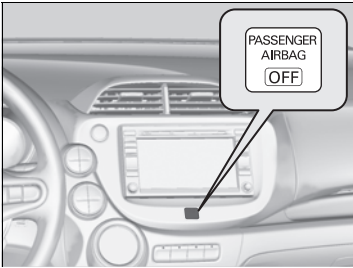

### ■ When the passenger airbag off indicator comes on

The indicator comes on to alert you that the passenger's front airbag has been turned off. This occurs when the weight sensors detect 65 lbs (29 kg) or less, the weight of an infant or small child, on the seat.

Infants and small children should always ride properly restrained in a back seat.

➤ **Child Safety** P. 56

Objects placed on the seat can also cause the indicator to come on.

If the front passenger seat is empty, the passenger's front airbag will not deploy and the indicator will not come on.

### ⊠ Passenger Airbag Off Indicator

If the indicator comes on with no front passenger and no objects on the passenger's seat, or with an adult riding there, something may be interfering with the weight sensors. Such as:

- An object hanging on the seat or in the seat-back pocket.
- A child seat or other object pressing against the rear of the seat-back.
- A rear passenger pushing or pulling on the back of the front passenger's seat.
- The front seat or seat-back is forced back against an object on the seat or floor behind it.
- An object placed under the front passenger's seat.

If none of these conditions exist, have your vehicle checked by an authorized Honda Fit EV dealer as soon as possible.

The passenger airbag off indicator may come on and go off repeatedly if the total weight on the seat is near the airbag cutoff threshold.

## ■ Side Airbag Off Indicator

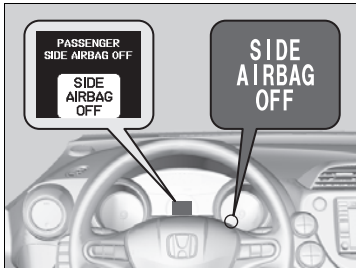

### ■ When the side airbag off indicator comes on

This indicator comes on if the passenger's side airbag has been turned off because the passenger is too small to be sitting in the front seat, is slouching or not sitting upright, or has leaned into the airbag's deployment path.

Unless the passenger is a smaller statured adult or a child, the indicator should go off when the passenger returns to a proper upright sitting position.

### ▶▶ Side Airbag Off Indicator

When you turn the power switch to ON **(II)**, the indicator should come on for a few seconds and then go out. If it doesn't come on, stays on, or comes on while driving without a passenger in the front seat, have the system checked by an authorized Honda Fit EV dealer as soon as possible.

## Airbag Care

---

You do not need to, and should not, perform any maintenance on or replace any airbag system components yourself. However, you should have your vehicle inspected by an authorized Honda Fit EV dealer in the following situations:

### ■ When the airbags have deployed

If an airbag has inflated, the control unit and other related parts must be replaced. Similarly, once an automatic seat belt tensioner has been activated, it must be replaced.

### ■ When the vehicle has been in a moderate-to-severe collision

Even if the airbags did not inflate, have an authorized Honda Fit EV dealer inspect the following: the driver's seat position sensor, weight sensors in the passenger's seat, front seat belt tensioners, and each seat belt that was worn during the crash.

### ■ Do not remove or modify a front seat without consulting an authorized Honda Fit EV dealer

This would likely disable the driver's seat position sensor or the weight sensors in the passenger's seat. If it is necessary to remove or modify a front seat to accommodate a person with disabilities, contact a Honda dealer, or American Honda Automobile Customer Service at 800-999-1009.

#### ✘ Airbag Care

We recommend against the use of salvaged airbag system components, including the airbag, tensioners, sensors, and control unit.



## Protecting Child Passengers

Each year, many children are injured or killed in vehicle crashes because they are either unrestrained or not properly restrained. In fact, vehicle accidents are the number one cause of death of children age 12 and under.

To reduce the number of child deaths and injuries, every state, Canadian province and territory requires that infants and children be properly restrained when they ride in a vehicle.

**Children should sit properly restrained in a rear seat.** This is because:

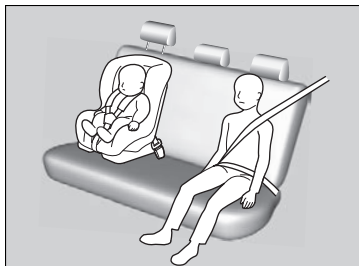

- An inflating front or side airbag can injure or kill a child sitting in the front seat.
- A child in the front seat is more likely to interfere with the driver's ability to safely control the vehicle.
- Statistics show that children of all sizes and ages are safer when they are properly restrained in a rear seat.

### Protecting Child Passengers

#### **WARNING**

**Children who are unrestrained or improperly restrained can be seriously injured or killed in a crash.**

**Any child too small for a seat belt should be properly restrained in a child seat. A larger child should be properly restrained with a seat belt, using a booster seat if necessary.**

The National Highway Traffic Safety Administration and Transport Canada recommend that all children age 12 and under be properly restrained in a rear seat. Some states or provinces/territories have laws restricting where children may ride.

- Any child who is too small to wear a seat belt correctly must be restrained in an approved child seat that is properly secured to the vehicle using either the lap belt portion of the lap/shoulder belt or the lower anchors of the LATCH system.
- Never hold a child on your lap because it is impossible to protect them in the event of a collision.
- Never put a seat belt over yourself and a child. During a crash, the belt would likely press deep into the child and cause serious or fatal injuries.
- Never let two children use the same seat belt. Both children could be very seriously injured in a crash.
- Do not allow children to operate the doors, windows or seat adjustments.
- Do not leave children in the vehicle unattended, especially in hot weather when the inside of the vehicle can get hot enough to kill them. They could also activate vehicle controls causing it to move unexpectedly.

## ▶▶ Protecting Child Passengers

**⚠ WARNING**

Allowing a child to play with a seat belt or wrap one around their neck can result in serious injury or death.

**Instruct children not to play with any seat belt and make sure any unused seat belt a child can reach is buckled, fully retracted, and locked.**

To deactivate a lockable retractor, release the buckle and allow the seat belt to wind up all the way.

To remind you of the passenger's front airbag hazards and child safety, your vehicle has warning labels on the dashboard (U.S. models) and on the front visors. Please read and follow the instructions on these labels.

▶▶ **Safety Labels** P. 68

## Safety of Infants and Small Children

### ■ Protecting Infants

An infant must be properly restrained in a rear-facing, reclining child seat until the infant reaches the seat maker's weight or height limit for the seat, and the infant is at least one year old.

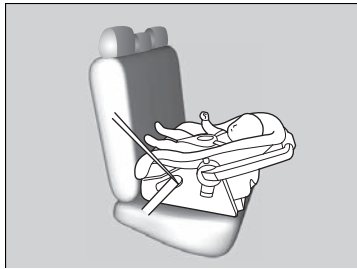

#### ■ Positioning a rear-facing child seat

Child seats must be placed and secured in a rear seating position.

When properly installed, a rear-facing child seat may prevent the driver or a front passenger from moving their seat all the way back, or from locking their seat-back in the desired position.

It can also interfere with proper operation of the passenger's advanced front airbag system.

➤ **Airbags** P. 41

If this occurs, we recommend that you install the child seat directly behind the front passenger's seat, move the seat as far forward as needed, and leave it unoccupied. Or, you may wish to get a smaller rear-facing child seat.

### ▶▶ Protecting Infants

## ⚠ WARNING

Placing a rear-facing child seat in the front seat can result in serious injury or death during a crash.

Always place a rear-facing child seat in the rear seat, not the front.

Rear-facing child seats should never be installed in a forward facing position.

Always refer to the child seat manufacturer's instructions before installation.

## Protecting Smaller Children

If a child is at least one year old and within the weight range indicated by the child seat manufacturer, the child should be properly restrained in a firmly secured forward-facing child seat.



### Forward-facing child seat placement

We strongly recommend placing a forward-facing child seat in a rear seating position.

Placing a forward-facing child seat in the front seat can be hazardous, even with advanced front airbags that automatically turn the passenger's front airbag off. A rear seat is the safest place for a child.

## Protecting Smaller Children

### WARNING

Placing a forward-facing child seat in the front seat can result in serious injury or death if the front airbag inflates.

If you must place a forward-facing child seat in front, move the vehicle seat as far back as possible, and properly restrain the child.

Educate yourself about the laws and regulations regarding child seat use where you are driving, and follow the child seat manufacturer's instructions.

Many experts recommend use of a rear-facing seat up to age two, if the child's height and weight are appropriate for a rear-facing seat.

## ■ Selecting a Child Seat

Most child seats are LATCH-compatible (Lower Anchors and Tethers for Children). Some have a rigid-type connector, while others have a flexible-type connector. Both are equally easy to use. Some existing and previously owned child seats can only be installed using the seat belt. Whichever type you choose, follow the child seat manufacturer's use and care instructions as well as the instructions in this manual. Proper installation is key to maximizing your child's safety.

In seating positions and vehicles not equipped with LATCH, a LATCH compatible child seat can be installed using the seat belt and a top tether for added security. This is because all child seats are required to be designed so that they can be secured with a lap belt or the lap part of a lap/shoulder belt. In addition, the child seat manufacturer may advise that a seat belt be used to attach a LATCH-compatible seat once a child reaches a specified weight. Please read the child seat owner's manual for proper installation instructions.

### ■ Important consideration when selecting a child seat

Make sure the child seat meets the following three requirements:

- The child seat is the correct type and size for the child.
- The child seat is the correct type for the seating position.
- The child seat is compliant with Federal Motor Vehicle Safety Standard 213 or Canadian Motor Vehicle Safety Standard 213.

## ▶▶ Selecting a Child Seat

Installation of a LATCH-compatible child seat is simple.

LATCH-compatible child seats have been developed to simplify the installation process and reduce the likelihood of injuries caused by incorrect installation.

## ■ Installing a LATCH-Compatible Child Seat

A LATCH-compatible child seat can be installed in either of the two outer rear seats. A child seat is attached to the lower anchors with either the rigid or flexible type of connectors.

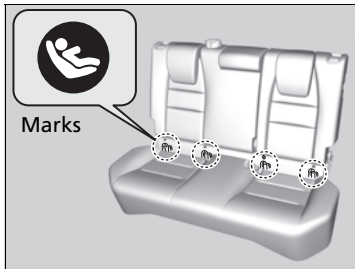

1. Locate the lower anchors under the marks.

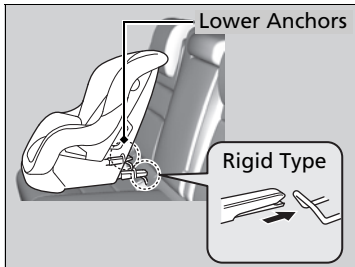

2. Place the child seat on the vehicle seat then attach the child seat to the lower anchors according to the instructions that came with the child seat.
  - ▶ When installing the child seat, make sure that the lower anchors are not obstructed by the seat belt or any other object.

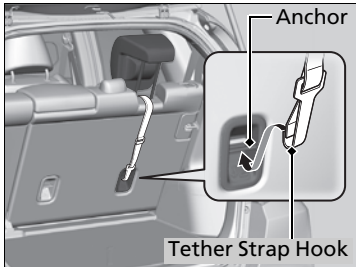
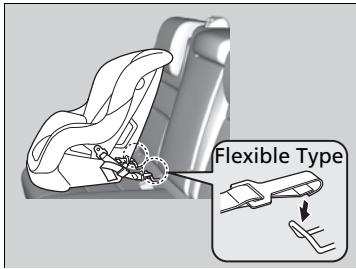

3. Put the head restraint to its upright, then route the tether strap between the head restraint legs, and secure the tether strap hook onto the anchor.
4. Tighten the tether strap as instructed by the child seat maker.
5. Make sure the child seat is firmly secured by rocking it forward and back and side to side; little movement should be felt.
6. Make sure any unused seat belt that a child can reach is buckled, the lockable retractor is activated, and the belt is fully retracted and locked.

#### ▶▶ Installing a LATCH-Compatible Child Seat

For your child's safety, when using a child seat installed using the LATCH system, make sure that the seat is properly secured to the vehicle. A child seat that is not properly secured will not adequately protect a child in a crash and may cause injury to the child or other vehicle occupants.

## ■ Installing a Child Seat with a Lap/Shoulder Seat Belt



1. Place the child seat on the vehicle seat.
2. Route the seat belt through the child seat according to the seat maker's instructions, and insert the latch plate into the buckle.
  - ▶ Insert the latch plate fully until it clicks.

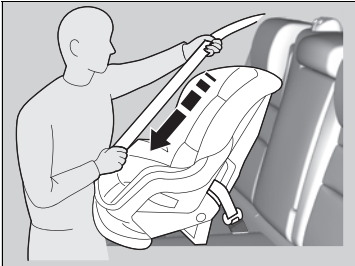

3. Slowly pull the shoulder part of the belt all the way out until it stops. This activates the lockable retractor.
4. Let the seat belt completely wind up into the retractor, then try to pull it out to make sure the retractor is locked.
  - ▶ If you are able to pull the shoulder belt out, the lockable retractor is not activated. Pull the seat belt all the way out, and repeat steps 3 – 4.

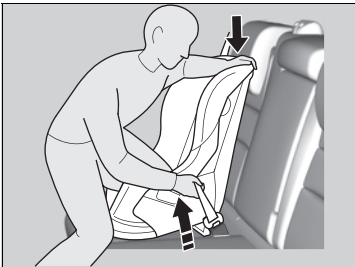

5. Grab the shoulder part of the seat belt near the buckle, and pull up to remove any slack from the lap part of the belt.
  - ▶ When doing this, place your weight on the child seat and push it into the vehicle seat.

### ⊠ Installing a Child Seat with a Lap/Shoulder Seat Belt

A child seat that is not properly secured will not adequately protect a child in a crash and may cause injury to the child or other vehicle occupants.

*Continued*



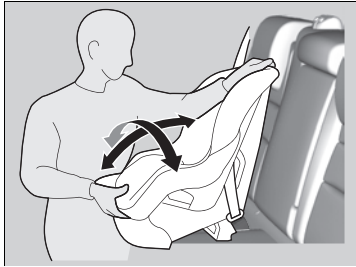

6. Make sure the child seat is firmly secured by rocking it forward and back and side to side; little movement should be felt.
7. Make sure any unused seat belt that a child can reach is buckled, the lockable retractor is activated, and the belt is fully retracted and locked.

#### ▶▶ Installing a Child Seat with a Lap/Shoulder Seat Belt

To deactivate a lockable retractor, release the buckle and allow the seat belt to wind up all the way.

#### ▶▶ Adding Security with a Tether

Since a tether can provide additional security to the lap/shoulder seat belt installation, we recommend using a tether whenever one is available.

### ■ Adding Security with a Tether

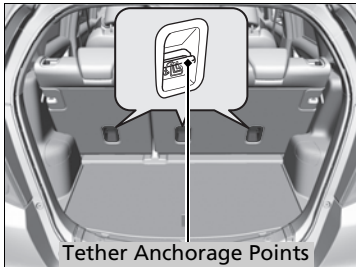

A tether anchorage point is provided behind each rear seating position. A child seat that is installed with a seat belt and comes with a tether can use the tether for additional security.

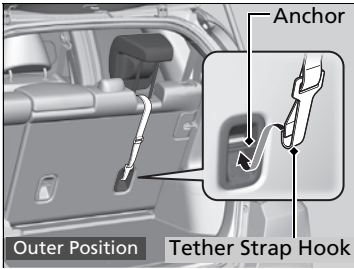

1. Put the head restraint to its upright, then route the tether strap through the head restraint legs. Make sure the strap is not twisted.
2. Secure the tether strap hook onto the anchor.
3. Tighten the tether strap as instructed by the child seat manufacturer.

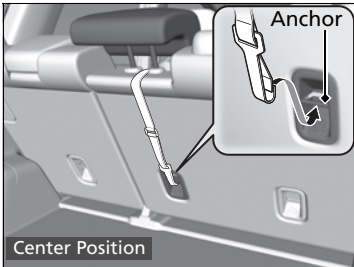

## Safety of Larger Children

### ■ Protecting Larger Children

The following pages give instructions on how to check proper seat belt fit, what kind of booster seat to use if one is needed, and important precautions for a child who must sit in front.

### ■ Checking Seat Belt Fit

When a child is too big for a child seat, secure the child in a rear seat using the lap/shoulder seat belt. Have the child sit upright and all the way back, then answer the following questions.



#### ■ Checklist

- Do the child's knees bend comfortably over the edge of the seat?
- Does the shoulder belt cross between the child's neck and arm?
- Is the lap part of the seat belt as low as possible, touching the child's thighs?
- Will the child be able to stay seated like this for the whole trip?

If you answer yes to all these questions, the child is ready to wear the lap/shoulder seat belt correctly. If you answer no to any question, the child needs to ride on a booster seat until the seat belt fits properly without a booster seat.

### ▶ Safety of Larger Children

## ⚠ WARNING

Allowing a child age 12 or under to sit in front can result in injury or death if the passenger's front airbag inflates.

If a larger child must ride in front, move the vehicle seat as far to the rear as possible, have the child sit up properly and wear the seat belt properly, using a booster seat if needed.

## Booster Seats

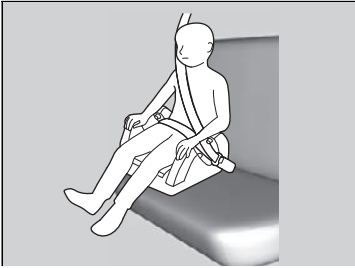

If a lap/shoulder seat belt cannot be used properly, position the child in a booster seat in a rear seating position. For the child's safety, check that the child meets the booster seat manufacturer's recommendations.

## Protecting Larger Children-Final Checks

Your vehicle has a rear seat where children can be properly restrained. If you ever have to carry a group of children, and a child must ride in front:

- Make sure you read and fully understand the instructions and safety information in this manual.
- Move the front passenger seat as far back as possible.
- Have the child sit upright and well back in the seat.
- Check that the seat belt is properly positioned so that the child is secure in the seat.

## Monitoring child passengers

We strongly recommend that you keep an eye on child passengers. Even older, more mature children sometimes need to be reminded to fasten their seat belts and sit up properly.

### Booster Seats

When installing a booster seat, make sure to read the instructions that came with it, and install the seat accordingly.

There are high- and low-type booster seats. Choose a booster seat that allows the child to wear the seat belt correctly.

Some U.S. states and Canadian provinces/territories require children to use a booster seat until they reach a given age or weight (e.g. 6 years or 60 lbs). Be sure to check current laws in the state or province, or territory where you intend to drive.

### Protecting Larger Children-Final Checks

## ⚠ WARNING

Allowing a child age 12 or under to sit in front can result in injury or death if the passenger's front airbag inflates.

If a larger child must ride in front, move the vehicle seat as far to the rear as possible, have the child sit up properly and wear the seat belt properly, using a booster seat if needed.

## Label Locations

These labels are in the locations shown. They warn you of potential hazards that can cause serious injury or death. Read these labels carefully.

If a label comes off or becomes hard to read (except for the dashboard label which may be removed by the owner), contact an authorized Honda Fit EV dealer for a replacement.

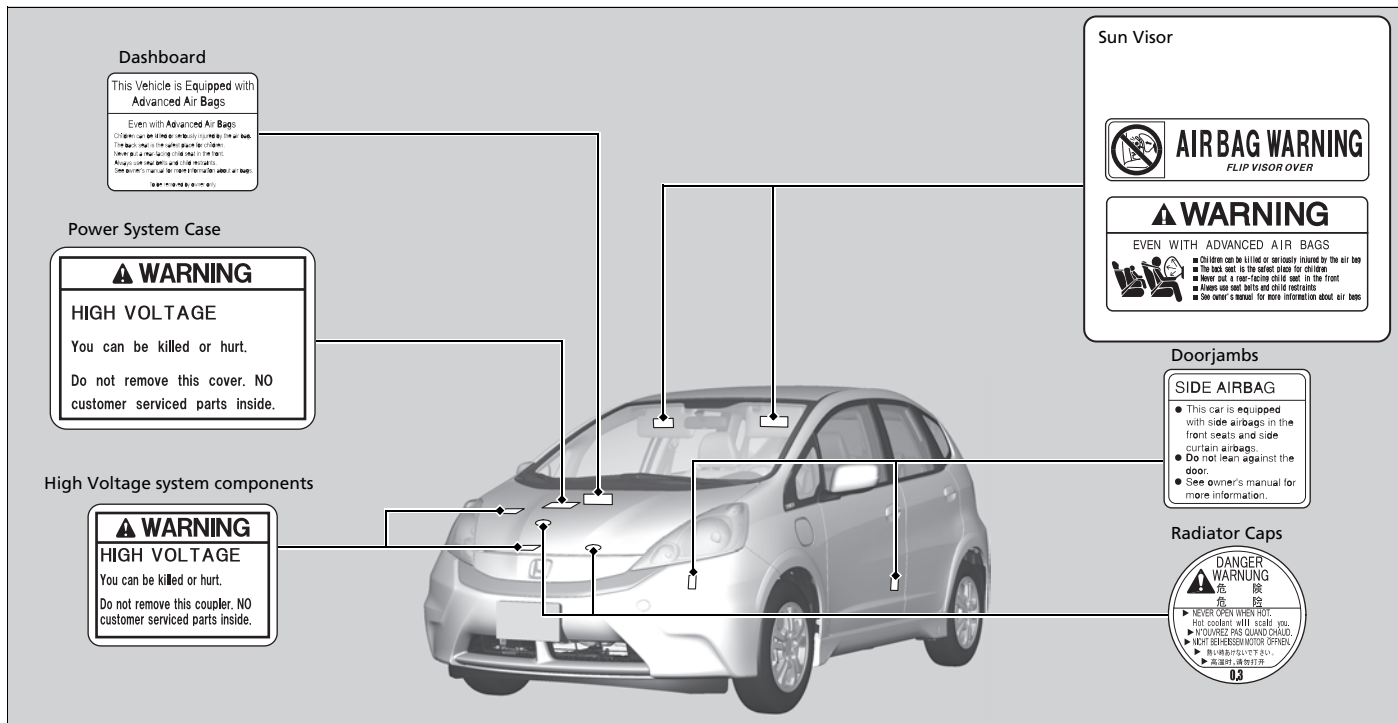























# Instrument Panel

This chapter describes the buttons, indicators, and gauges that are used while driving.

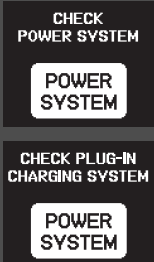

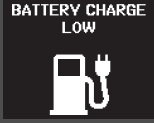











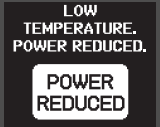



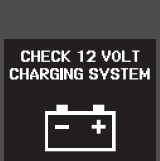

<b>Indicators</b> .....	70
Multi-Information Display Warning and Information Messages.....	79
<b>Gauges and Multi-Information Displays</b>	
Gauges.....	81
Multi-Information Display .....	83









Indicator	Name	On/Blinking	Explanation	Message
BRAKE	Brake Warning Indicator (Red)	<ul style="list-style-type: none"> <li>Comes on for a few seconds when you turn the power switch to ON , then goes off.</li> <li>Comes on when the parking brake is applied, and goes off when it is released.</li> <li>Comes on when the brake fluid level is low.</li> <li>Comes on if there is a problem with the brake system or ABS.</li> </ul>	<ul style="list-style-type: none"> <li><b>Comes on while driving</b> - Make sure the parking brake is released. Check the brake fluid level.</li> <li><b>Comes on along with the brake system indicator</b> - Immediately stop in a safe place. Contact an authorized Honda Fit EV dealer for repair. The brake pedal becomes harder to operate. Depress the pedal further than you normally do.</li> <li><b>Comes on along with the ABS indicator</b> - Have the vehicle checked by an authorized Honda Fit EV dealer.  <b>If the Brake Warning Indicator Comes On</b> P. 243</li> </ul>	       
	Brake System Indicator (Amber)	<ul style="list-style-type: none"> <li>Comes on for a few seconds when you turn the power switch to ON , then goes off.</li> <li>Comes on if there is a problem with the cooperative control with regenerative braking.</li> </ul>	<ul style="list-style-type: none"> <li><b>Stays on constantly</b> - Avoid high speeds and sudden braking. Take the vehicle to an authorized Honda Fit EV dealer immediately.</li> </ul>	 



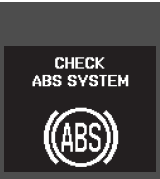

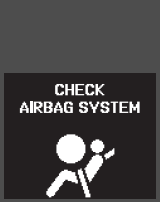

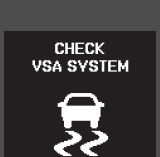
Indicator	Name	On/Blinking	Explanation	Message
	<b>POWER SYSTEM</b> Indicator	<ul style="list-style-type: none"> <li>Comes on when you turn the power switch to ON , and goes off.</li> <li>Comes on if there is a problem with the electric vehicle system or plug-in charging system.</li> </ul>	<ul style="list-style-type: none"> <li><b>Comes on while driving</b> - Have the vehicle checked by an authorized Honda Fit EV dealer.</li> <li><b>Comes on when you turn the power switch to ON  after having charged your vehicle</b> - Have the vehicle checked by an authorized Honda Fit EV dealer.</li> </ul>	
	Low Charge Indicator	<ul style="list-style-type: none"> <li>Comes on when the High Voltage battery is running low.</li> </ul>	<ul style="list-style-type: none"> <li><b>Comes on</b> - There is a decrease in acceleration performance. Recharge the High Voltage battery as soon as possible.</li> </ul>	
	Charge Connector Indicator	<ul style="list-style-type: none"> <li>Comes on for a few seconds when you turn the power switch to ON , then goes off.</li> <li>Comes on when the charge connector is connected to the inlet.</li> </ul>	<ul style="list-style-type: none"> <li>The vehicle does not move while the charge connector is plugged into the inlet.</li> </ul>	





















Indicator	Name	On/Blinking	Explanation	Message
	<b>POWER REDUCED</b> Indicator	<ul style="list-style-type: none"> <li>Comes on for a few seconds when you turn the power switch to ON , then goes off.</li> </ul>	<p>—</p>	<p>—</p>
		<ul style="list-style-type: none"> <li>Comes on when the power system temperature is high.</li> </ul>	<ul style="list-style-type: none"> <li>Park in a safe place, and cool the system down.   <b>Overheating</b> P. 241</li> </ul>	
		<ul style="list-style-type: none"> <li>Comes on when the power system temperature is low.</li> </ul>	<ul style="list-style-type: none"> <li>Goes off once you start charging, or driving as the High Voltage battery warms up.</li> </ul>	
		<ul style="list-style-type: none"> <li>Comes on when the High Voltage battery charge level is extremely low.</li> </ul>	<ul style="list-style-type: none"> <li><b>Caused by the low battery charge level</b> - Immediately charge the High Voltage battery.</li> </ul>	
	<b>12 Volt Battery Charging System Indicator</b>	<ul style="list-style-type: none"> <li>Comes on when you turn the power switch to ON , and goes off when the power system is on.</li> <li>Comes on when the 12 volt battery is not charging.</li> </ul>	<ul style="list-style-type: none"> <li><b>Comes on while driving</b> - Turn off the climate control system and rear defogger to reduce electricity consumption. Have the vehicle checked by an authorized Honda Fit EV dealer.   <b>If the 12 Volt Battery Charging System Indicator Comes On</b> P. 242</li> </ul>	











Indicator	Name	On/Blinking	Explanation	Message
	Transmission Indicator	<ul style="list-style-type: none"> <li>Comes on for a few seconds when you turn the power switch to ON , then goes off.</li> <li>Blinks if the shift lever has a problem.</li> </ul>	<ul style="list-style-type: none"> <li><b>Blinks while driving</b> - Avoid sudden starts and acceleration and have the vehicle checked by an authorized Honda Fit EV dealer immediately.</li> </ul>	—
	Shift Lever Position Indicator	<ul style="list-style-type: none"> <li>Indicates the current shift lever position.</li> </ul>	<p> <b>Shifting</b> P. 153</p>	—
	Seat Belt Reminder Indicator	<ul style="list-style-type: none"> <li>Comes on and the beeper sounds if you are not wearing a seat belt when you turn the power switch to ON .</li> <li>If the front passenger is not wearing a seat belt, the indicator comes on about a few seconds later.</li> <li>Blinks while driving if either you or the front passenger has not fastened a seat belt. The beeper sounds and the indicator blinks at regular intervals.</li> </ul>	<ul style="list-style-type: none"> <li>The beeper stops and the indicator goes off when you and the front passenger fasten your seat belts.</li> <li><b>Stays on after you or the front passenger has fastened the seat belt</b> - A detection error may have occurred in the sensor. Have the vehicle checked by an authorized Honda Fit EV dealer. <ul style="list-style-type: none"> <li> <b>Seat Belt Reminder</b> P. 35</li> </ul> </li> </ul>	 

Indicator	Name	On/Blinking	Explanation	Message
	<b>ABS</b> (Anti-lock Brake System) Indicator	<ul style="list-style-type: none"> <li>Comes on for a few seconds when you turn the power switch to ON , then goes off.</li> <li>If it comes on at any other time, there is a problem with the ABS.</li> </ul>	<ul style="list-style-type: none"> <li><b>Stays on constantly</b> - Have the vehicle checked by an authorized Honda Fit EV dealer. With this indicator on, your vehicle still has normal braking ability but no anti-lock function.                             <ul style="list-style-type: none"> <li>➤ <b>ABS (Anti-lock Brake System)</b> P. 167</li> </ul> </li> </ul>	
	Supplemental Restraint System Indicator	<ul style="list-style-type: none"> <li>Comes on for a few seconds when you turn the power switch to ON , then goes off.</li> <li>Comes on if a problem with any of the following is detected:                             <ul style="list-style-type: none"> <li>- Supplemental restraint system</li> <li>- Side airbag system</li> <li>- Side curtain airbag system</li> <li>- Seat belt tensioner</li> </ul> </li> </ul>	<ul style="list-style-type: none"> <li><b>Stays on constantly or does not come on at all</b> - Have the vehicle checked by an authorized Honda Fit EV dealer.</li> </ul>	
	VSA® (Vehicle Stability Assist) System Indicator	<ul style="list-style-type: none"> <li>Comes on for a few seconds when you turn the power switch to ON , then goes off.</li> <li>Blinks when VSA® is active.</li> <li>Comes on if there is a problem with the VSA® system.</li> </ul>	<ul style="list-style-type: none"> <li><b>Stays on constantly</b> - Have the vehicle checked by an authorized Honda Fit EV dealer.                             <ul style="list-style-type: none"> <li>➤ <b>VSA® (Vehicle Stability Assist), aka ESC (Electronic Stability Control), System</b> P. 160</li> </ul> </li> </ul>	
	VSA® (Vehicle Stability Assist) OFF Indicator	<ul style="list-style-type: none"> <li>Comes on for a few seconds when you turn the power switch to ON , then goes off.</li> <li>Comes on when you deactivate VSA®.</li> </ul>	<ul style="list-style-type: none"> <li>➤ <b>VSA® On and Off</b> P. 161</li> </ul>	—

Indicator	Name	On/Blinking	Explanation	Message
	Door and Tailgate Open Indicator	<ul style="list-style-type: none"> <li>• Comes on for a few seconds if you turn the power switch to ON <b>II</b>, then goes off.</li> <li>• Comes on if any door or the tailgate is not completely closed.</li> <li>• The beeper sounds and the indicator comes on if any door is opened while driving.</li> </ul>	<ul style="list-style-type: none"> <li>• Goes off when all doors and the tailgate are closed.</li> </ul>	
	EPS (Electric Power Steering) System Indicator	<ul style="list-style-type: none"> <li>• Comes on when you turn the power switch to ON <b>II</b>, and goes off when the power system is on.</li> <li>• Comes on if there is a problem with the EPS (Electric Power Steering) System.</li> </ul>	<ul style="list-style-type: none"> <li>• <b>Stays on constantly or does not come on at all</b> - Have the vehicle checked by an authorized Honda Fit EV dealer.                             <ul style="list-style-type: none"> <li>▶ <b>If the EPS System Indicator Comes On</b> P. 243</li> </ul> </li> </ul>	
	Low Tire Pressure/TPMS Indicator	<ul style="list-style-type: none"> <li>• Comes on for a few seconds when you turn the power switch to ON <b>II</b>.</li> <li>• Comes on if the tire pressure of any of the tires becomes significantly low.</li> <li>• Blinks for about one minute, and then stays on if there is a problem with the TPMS.</li> </ul>	<ul style="list-style-type: none"> <li>• <b>Blinks and remains on</b> - Have the vehicle checked by an authorized Honda Fit EV dealer.</li> <li>• <b>Comes on while driving</b> - Stop in a safe place, check tire pressures, and inflate the tire(s) if necessary.                             <ul style="list-style-type: none"> <li>▶ <b>If the Low Tire Pressure/TPMS Indicator Comes On or Blinks</b> P. 244</li> </ul> </li> </ul>	 

Indicator	Name	On/Blinking	Explanation	Message
	Side Airbag Off Indicator	<ul style="list-style-type: none"> <li>Comes on for a few seconds when you turn the power switch to ON , then goes off.</li> <li>Comes on when the passenger side airbag system is automatically shut off.</li> </ul>	<ul style="list-style-type: none"> <li>It does not mean there is a problem with your side airbags.</li> <li><b>Comes on when nobody is sitting in the passenger seat</b> - Have the vehicle checked by an authorized Honda Fit EV dealer.</li> <li><b>Comes on when someone is sitting in the seat</b> - Have the passenger sit properly.</li> </ul>	
	System Message Indicator	<ul style="list-style-type: none"> <li>Comes on for a few seconds when you turn the power switch to ON , then goes off.</li> <li>Comes on along with a beep when a problem is detected. A system message on the multi-information display appears at the same time.</li> </ul>	<ul style="list-style-type: none"> <li>While the indicator is on, press the / (information) button to see the message again.</li> <li>Refer to the indicator information in this chapter when a system message appears on the multi-information display. Take appropriate action for the message.</li> <li>The multi-information display does not return to the normal screen unless the warning is canceled, or the / button is pressed.</li> </ul>	—
	Turn Signal Indicators	<ul style="list-style-type: none"> <li>The turn signal indicators blink when you operate the turn signal lever.</li> <li>If you press the hazard warning button, both indicators and all turn signals blink at the same time.</li> </ul>	<ul style="list-style-type: none"> <li><b>Does not blink or blinks rapidly</b> - A turn signal light bulb has blown. Change the bulb immediately.   <b>Replacing Light Bulbs</b> P. 203, 205</li> </ul>	—







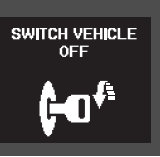

Indicator	Name	On/Blinking	Explanation	Message
	High Beam Indicator	<ul style="list-style-type: none"> <li>Comes on when the high beam headlights are on.</li> </ul>	—	—
	Lights On Indicator	<ul style="list-style-type: none"> <li>Comes on whenever the light switch is on.</li> </ul>	<ul style="list-style-type: none"> <li>If you remove the key from the power switch while the lights are on, a chime sounds when the driver's door is opened.</li> </ul>	—
	Immobilizer System Indicator	<ul style="list-style-type: none"> <li>Comes on briefly when you turn the power switch to ON , then goes off.</li> <li>Comes on if the immobilizer system cannot recognize the key information.</li> </ul>	<ul style="list-style-type: none"> <li><b>Blinks</b> - You cannot start the motor. Turn the power switch to LOCK , pull the key out, and then insert the key and turn it to ON  again.</li> <li><b>Repeatedly blinks</b> - The system may be malfunctioning. Have the vehicle checked by an authorized Honda Fit EV dealer.</li> <li>Do not attempt to alter this system or add other devices to it. Electrical problems can occur.</li> </ul>	—
	Security System Alarm Indicator	<ul style="list-style-type: none"> <li>Blinks when the security system alarm has been set.</li> </ul>	 <b>Security System Alarm</b> P. 107	—

Indicator	Name	On/Blinking	Explanation	Message
	<b>CRUISE MAIN</b> Indicator	<ul style="list-style-type: none"> <li>Comes on when you press the <b>CRUISE</b> button.</li> </ul>	➤ <b>Cruise Control</b> P. 157	—
	<b>CRUISE CONTROL</b> Indicator	<ul style="list-style-type: none"> <li>Comes on if you have set a speed for cruise control.</li> </ul>	➤ <b>Cruise Control</b> P. 157	—
	<b>SPORT</b> Mode Indicator* <sup>1</sup>	<ul style="list-style-type: none"> <li>Comes on for a few seconds when you turn the power switch to ON .</li> <li>Comes on when you press the <b>SPORT</b> mode button.</li> </ul>	➤ <b>3-Mode Drive System</b> P. 155	
	<b>NORMAL</b> Mode Indicator* <sup>1</sup>	<ul style="list-style-type: none"> <li>Comes on for a few seconds when you turn the power switch to ON .</li> <li>Comes on when you press the <b>NORMAL</b> mode button.</li> </ul>	➤ <b>3-Mode Drive System</b> P. 155	
	<b>ECON</b> Mode Indicator* <sup>1</sup>	<ul style="list-style-type: none"> <li>Comes on for a few seconds when you turn the power switch to ON .</li> <li>Comes on when you press the <b>ECON</b> mode button.</li> </ul>	➤ <b>3-Mode Drive System</b> P. 155	



\*1: The driving mode message on the multi-information display appears for a few seconds when you press the appropriate mode button.

## Multi-Information Display Warning and Information Messages

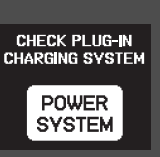
The following messages appear only on the multi-information display. Press the  (information) button to see the message again with the system message indicator on.

Message	Condition	Explanation
 <p>SWITCH VEHICLE OFF</p>	<ul style="list-style-type: none"> <li>Appears when you unplug the charge connector while the power switch is in ON .</li> </ul>	<ul style="list-style-type: none"> <li>Turn the power switch to ACCESSORY , and then, back to ON  again.</li> </ul>
 <p>REMOVE KEY</p>	<ul style="list-style-type: none"> <li>Appears when you open the driver's door while the key is in LOCK .</li> </ul>	<ul style="list-style-type: none"> <li>Remove the key from the power switch.</li> </ul>
 <p>RETURN IGNITION SWITCH TO LOCK (O) POSITION</p>	<ul style="list-style-type: none"> <li>Appears when you open the driver's door while the key is in ACCESSORY .</li> </ul>	<ul style="list-style-type: none"> <li>Turn the power switch to LOCK , then remove the key.</li> </ul>
 <p>CHECK PLUG-IN CHARGING SYSTEM</p> <p>POWER SYSTEM</p>	<ul style="list-style-type: none"> <li>Appears when there is a problem with the plug-in charging system or the charging station outlet.</li> </ul>	<ul style="list-style-type: none"> <li><b>This message only</b> - There may be a problem with the charging station outlet. Consult with the instructions provided at the station or a qualified technician. If the outlet works properly, have the vehicle checked by an authorized Honda Fit EV dealer.</li> <li><b>Comes on with the POWER SYSTEM indicator</b> - Have the vehicle checked by an authorized Honda Fit EV dealer.</li> </ul>



Message	Condition	Explanation
	<ul style="list-style-type: none"> <li>Appears when the key is turned to ACCESSORY <b>I</b> from ON <b>II</b>. (The driver's door is closed.)</li> </ul>	<p>—</p>
	<ul style="list-style-type: none"> <li>Appears when the scheduled maintenance is due soon.</li> <li>Consequently, <b>MAINTENANCE REQUIRED NOW</b> follow.</li> </ul>	<p>➤ <b>Reminder Message on the Multi-Information Display</b> P. 191</p>
	<ul style="list-style-type: none"> <li>Appears while you are customizing the settings for the following reasons: The shift lever is moved out of <b>P</b>.</li> </ul>	<p>➤ <b>Customized Features</b> P. 89</p>

## Gauges

Gauges include the speedometer, power/charge gauge, High Voltage battery charge level gauge, range display and related indicators. They are displayed when the power switch is in ON **II**.

### Speedometer

Displays your driving speed in mph or km/h.

### POWER/CHARGE Gauge

#### Electric motor

The degree to which the electric motor is being powered is displayed by the needle on the **POWER** side.

#### Battery charge in progress

The degree to which the High Voltage battery is being charged is displayed by the needle on the **CHARGE** side.

### Speedometer

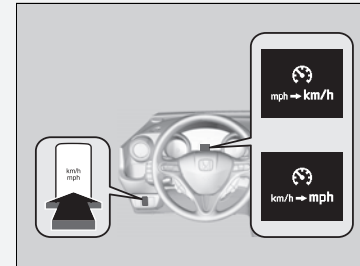

Press and hold the kmh/mpg change button until you hear a beep. The speedometer reading and the displayed measurements switch between mph and km/h, or the units corresponding to the item.

*Continued*

## ■ High Voltage Battery Charge Level Gauge

Shows the remaining High Voltage battery charge level.

## ■ Electricity Consumption Indicators

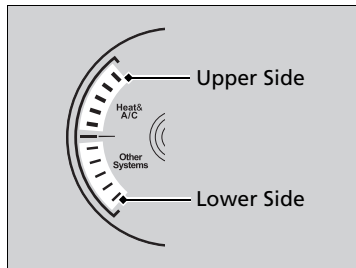

The more electricity the climate control system consumes, the indicators in the upper side increase.

The more electricity the electronic accessories consumes, the indicators in the lower side increase.

## ■ Range Display

Shows the estimated distance you can travel on the remaining power.  
The displayed range changes by your selected driving mode.

▶ **3-Mode Drive System** P. 14, 155

## ▶ High Voltage Battery Charge Level Gauge

The High Voltage battery charge level may decrease under the following conditions:

- When the 12 volt battery has been replaced.
- When the 12 volt battery has been disconnected.
- When the High Voltage battery control system corrects its reading.

The charge level reading will be corrected automatically while driving.

Changes in the temperature of the High Voltage battery can increase or decrease the battery's charging capacity. If temperature changes cause the battery's capacity to change, the number of indicators in the battery charge level gauge may also change, even if the amount of charging remains the same.

## Multi-Information Display

The multi-information display shows the odometer, trip meter, outside temperature indicator, and other gauges. It also displays important messages such as warnings and other helpful information.

### Switching the Display

Press the  (information) button or the **SEL/RESET** button to change the display.

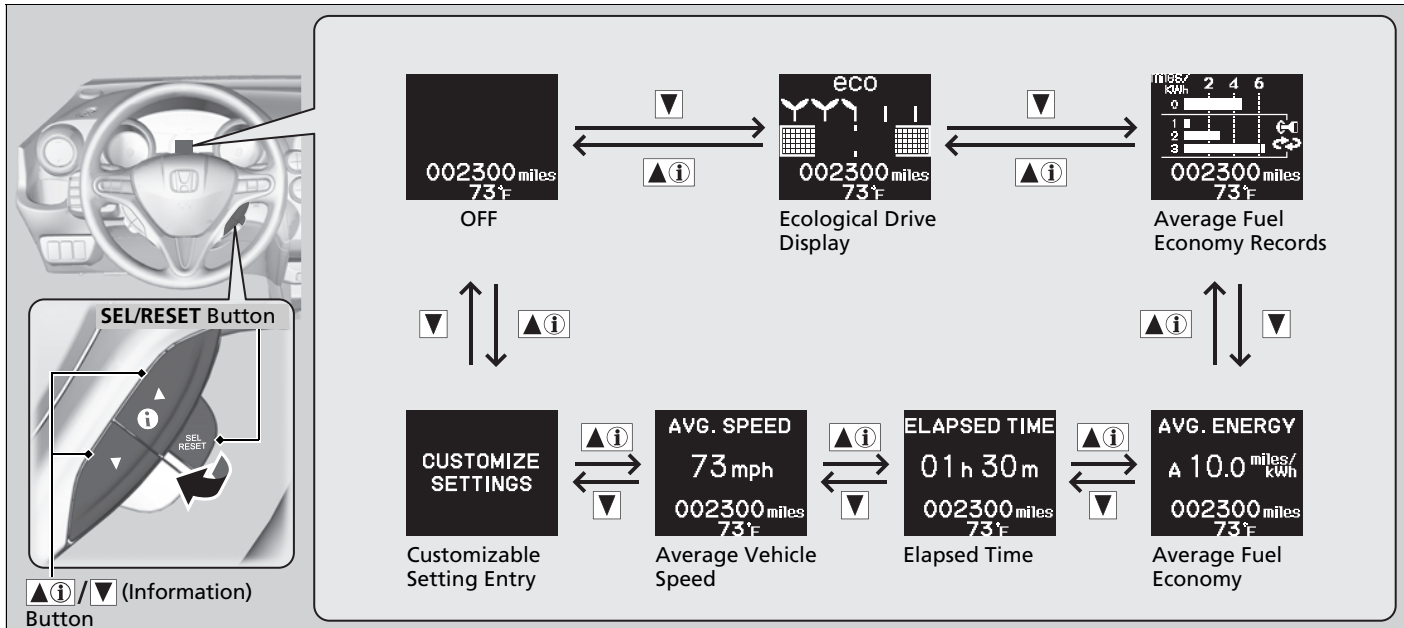

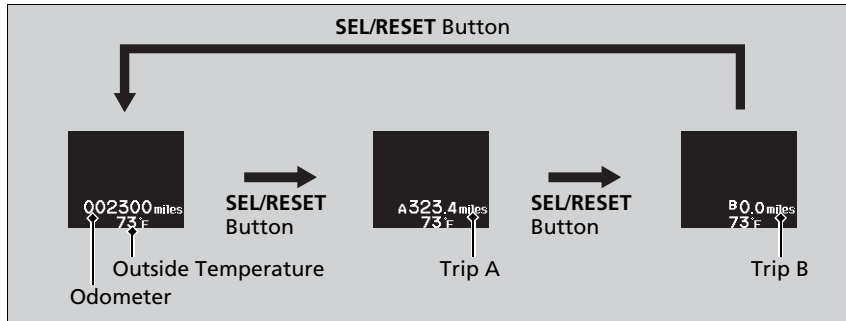

### ■ Odometer

Shows the total number of miles or kilometers that your vehicle has accumulated.

### ■ Trip Meter

Shows the total number of miles or kilometers driven since the last reset. Meters A and B can be used to measure two separate trips.

#### ■ Resetting a trip meter

To reset a trip meter, display it, then press and hold the **SEL/RESET** button. The trip meter is reset to **0.0**.

#### ☒ Trip Meter

Switch between trip meter A and trip meter B by pressing the **SEL/RESET** button.

## ■ Outside Temperature

Shows the outside temperature in Fahrenheit.

### ■ Adjusting the outside temperature display

Adjust the temperature reading up to  $\pm 5$  °F if the temperature reading seems incorrect.

➤ **Customized Features** P. 89

## ■ Elapsed Time

Shows the time during one drive cycle.

## ■ Average Speed

Shows the average speed in mph or km/h since the last time Trip A was reset.

### ⌘ Outside Temperature

The temperature sensor is in the front bumper. Road heat and exhaust from another vehicle can affect the temperature reading when your vehicle speed is less than 19 mph (30 km/h).

It may take several minutes for the display to be updated after the temperature reading has stabilized.

Use the multi-information display's customized features to correct the temperature.

➤ **Customized Features** P. 89

### ⌘ Elapsed Time

You can change the elapsed time reset criteria.

➤ **Customized Features** P. 89

### ■ Average Fuel Economy Records

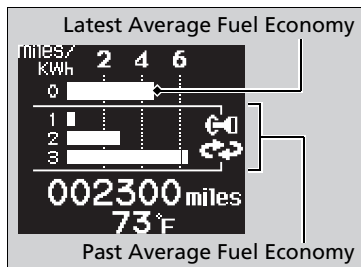

Shows the average fuel economy for the last three driving cycles (1-3), and the current driving cycle (0) in miles/kWh or km/kWh.

Each time you turn the power switch to ON **II**, the display is updated, and the oldest record is deleted.

### ■ Average Fuel Economy

Shows the estimated average fuel economy of Trip A and B in miles/kWh or km/kWh. The display is updated at set intervals. When a trip meter is reset, the average fuel economy is also reset.

#### ▶▶ Average Fuel Economy

You can change whether to reset the average fuel economy.

▶▶ **Customized Features** P. 89

## Ecological Drive Display

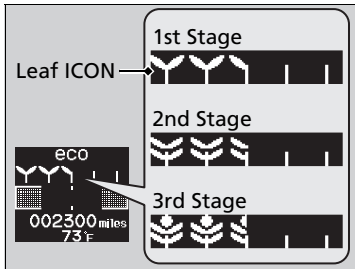

### Real-Time score

The Eco assist scoring system is a point system you can use to monitor your driving style and its impact on energy economy. Points are represented by leaf icons on the multi-information display. Leaves are:

- Accumulated when your driving style is energy efficient.
- Deducted when your style is not energy efficient.

### Reset the system

To clear all leaves and lifetime points, complete the following steps within 30 seconds, and do not turn on the power system.

1. The shift lever must be in **P**.
2. Turn the power switch to ON **II**.
3. If the system is in ECON mode, press the **NORMAL** mode button.
4. Depress the brake pedal twice.
  - ▶ The ambient meter color changes from white to green.
  - ▶ When the **ENERGY EFFICIENCY BACKLIGHT** setting on the multi-information display is off, the color stays in white.
5. Press the **ECON** mode button.
6. Press the **NORMAL** mode button.
  - ▶ The ambient meter color turns off.
7. Turn the power switch to LOCK **0**.



### ■ Feedback with eco drive bar

The bar extends to the right or left of the center line while driving. The more aggressive the acceleration is, the further the bar extends to the right. The more aggressive the deceleration is, the further the bar extends to the left. Keep the bar near the center line for better fuel economy while driving.

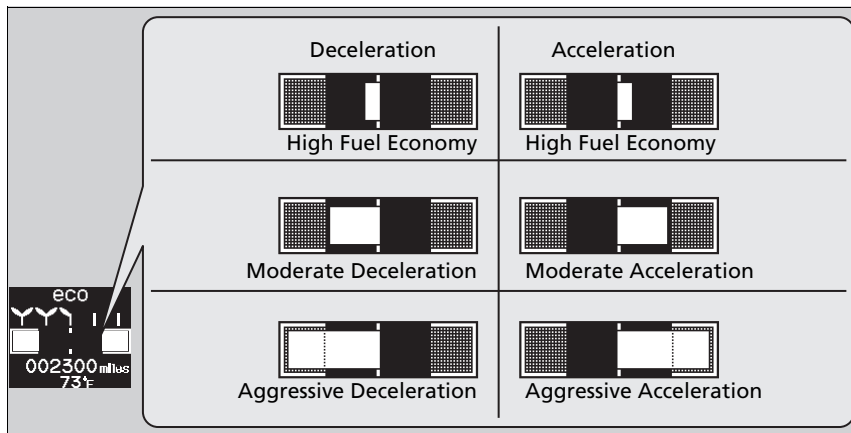

### ▣ Feedback with eco drive bar

The ambient meter color changes corresponding to the level of eco drive bar extension.

### ■ Charge Timer Setting

You can set the timer for the High Voltage battery charge.

➔ **Using a Timer** P. 182

## ■ Customized Features



Use the multi-information display to customize certain features.

### ■ How to customize

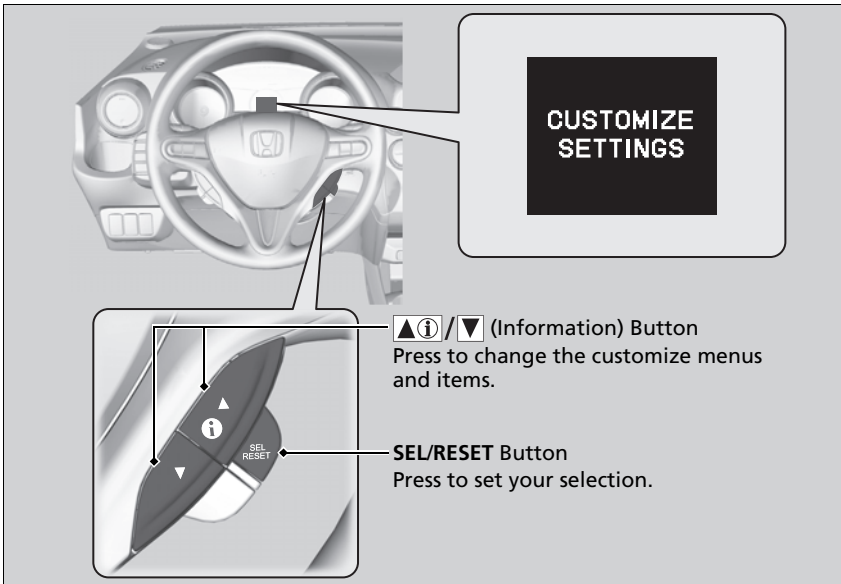
Press the / button to select **CUSTOMIZE SETTINGS** while the power switch is in ON .



### ☒ Customized Features

To customize other features, press the **SEL/RESET** button on the **CHANGE SETTINGS** screen, then press the / button.

➤ **List of customizable options** P. 91

➤ **Example for customizing settings** P. 93

When you customize settings:  
Shift to .

### ■ Customization flow

Press the button to select **CUSTOMIZE SETTINGS** and press the **SEL/RESET** button.

Instrument Panel

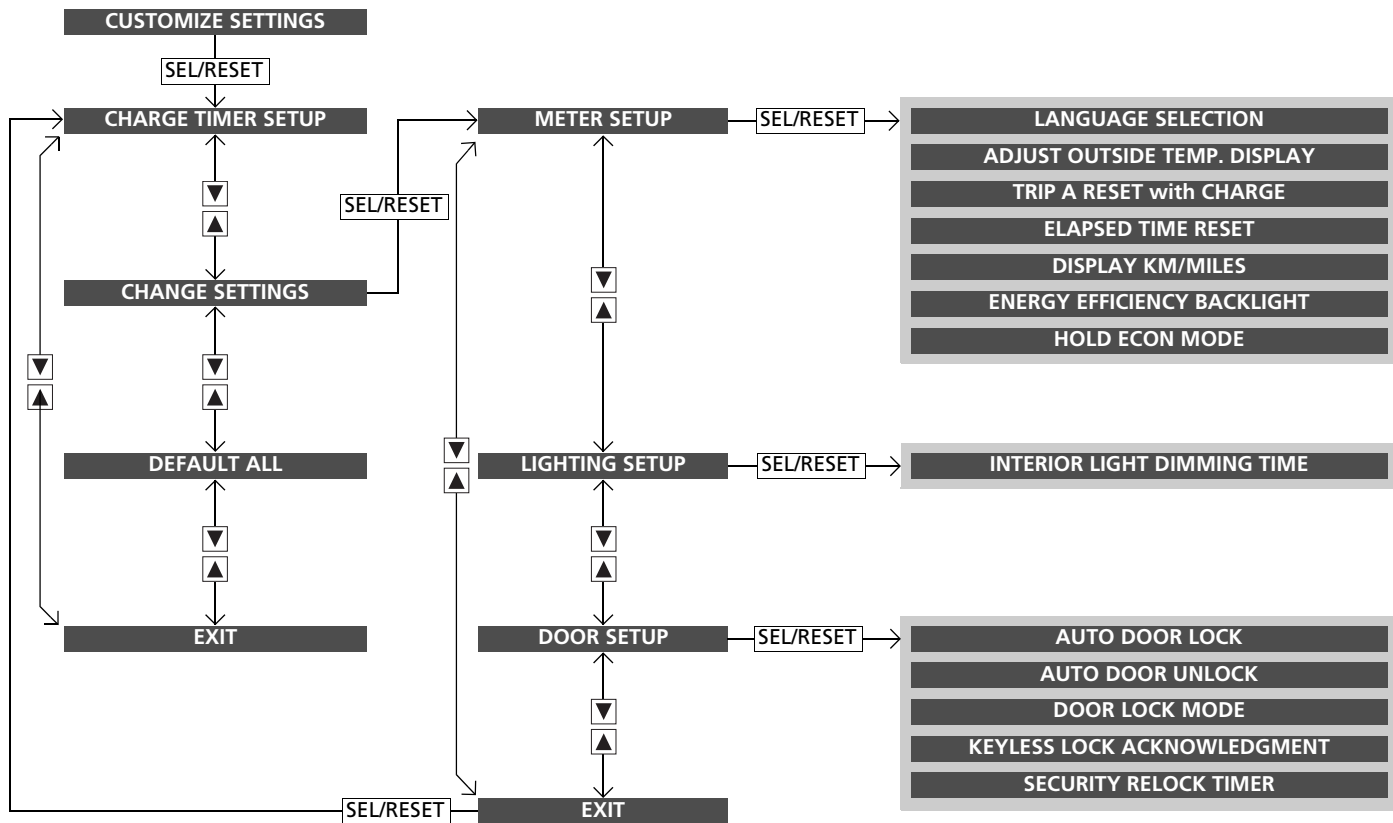

■ List of customizable options

Setup Group	Customizable Features	Description	Selectable settings
<b>CHARGE TIMER SETUP</b>	Sets the timer for the High Voltage battery charge.	TIMER	<b>ON/OFF*<sup>1</sup></b>
		MODE	<b>TIME*<sup>1</sup>/FULL</b>
		START	00:00 ~ 23:50
		END	00:00 ~ 23:50
	<b>LANGUAGE SELECTION</b>	Changes the displayed language.	<b>English*<sup>1</sup>/French/Spanish</b>
	<b>ADJUST OUTSIDE TEMP. DISPLAY</b>	Adjusts the temperature reading by a few degrees.	-5°F ~ ±0°F* <sup>1</sup> ~ +5°F
<b>METER SETUP</b>	<b>TRIP A RESET with CHARGE</b>	Sets Trip A and the average fuel economy to reset when you recharge.	<b>ON/OFF*<sup>1</sup></b>
	<b>ELAPSED TIME RESET</b>	Changes the resetting conditions of the elapsed time.	<b>IGN OFF*<sup>1</sup>/TRIP A/TRIP B</b>
	<b>DISPLAY KM/MILES</b>	Changes the displayed measurement on the multi-information display and the range display.	<b>AUTO*<sup>1</sup>/KM/MILES</b>
	<b>ENERGY EFFICIENCY BACKLIGHT</b>	Turns the ambient meter feature on and off.	<b>ON*<sup>1</sup>/OFF</b>
	<b>HOLD ECON MODE</b>	Maintains ECON mode.	<b>ON*<sup>1</sup>/OFF</b>
<b>LIGHTING SETUP</b>	<b>INTERIOR LIGHT DIMMING TIME</b>	Changes the length of time the interior lights stay on after you close the doors.	<b>60 sec/30 sec*<sup>1</sup>/15 sec</b>

\*1: Default Setting

Setup Group	Customizable Features	Description	Selectable settings
<b>DOOR SETUP</b>	<b>AUTO DOOR LOCK</b>	Changes the setting for the automatic locking feature.	<b>OFF/WITH VEH SPD<sup>*1</sup>/SHIFT FROM <input type="checkbox"/> P</b>
	<b>AUTO DOOR UNLOCK</b>	Changes the setting for when the doors and the tailgate unlock automatically.	<b>OFF/DRIVER DOOR With SHIFT to <input type="checkbox"/> P<sup>*1</sup>/ALL DOORS With SHIFT to <input type="checkbox"/> P/DRIVER DOOR With IGN OFF/ALL DOORS With IGN OFF</b>
	<b>DOOR LOCK MODE</b>	Sets up either the driver's door or all doors to unlock on the first operation of the remote or key.	<b>DRIVER DOOR<sup>*1</sup>/ALL DOORS</b>
	<b>KEYLESS LOCK ACKNOWLEDGMENT</b>	LOCK/UNLOCK - The exterior lights flash. LOCK (2nd push) - The beeper sounds.	<b>ON<sup>*1</sup>/OFF</b>
	<b>SECURITY RELOCK TIMER</b>	Changes the time it takes for the doors and the tailgate to relock and the security system to set after you unlock the vehicle without opening any door and the tailgate.	<b>90 sec/60 sec/30 sec<sup>*1</sup></b>
<b>DEFAULT ALL</b>		Sets/Cancel all the customized settings as default.	<b>CANCEL/SET</b>

\*1:Default Setting

### ■ Example for customizing settings

The steps for changing the **TRIP A RESET with CHARGE** setting to **ON** are shown below. The default setting for **TRIP A RESET with CHARGE** is **OFF**.

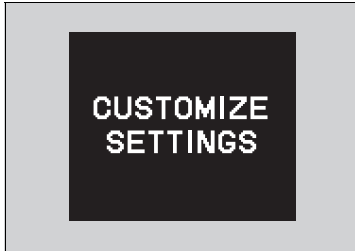

1. Press and release the /▼ button until **CUSTOMIZE SETTINGS** appears on the display.
2. Press the **SEL/RESET** button.
  - ▶ **CHARGE TIMER SETUP** appears on the display.

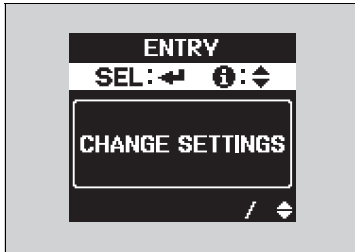

3. Press and release the /▼ button until **CHANGE SETTINGS** appears on the display.

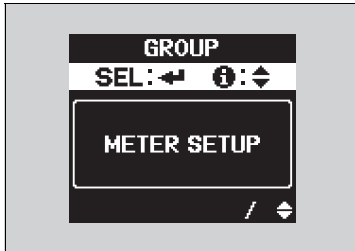

4. Press the **SEL/RESET** button.
  - ▶ **METER SETUP** appears on the display.
5. Press the **SEL/RESET** button.
  - ▶ **LANGUAGE SELECTION** appears first on the display.

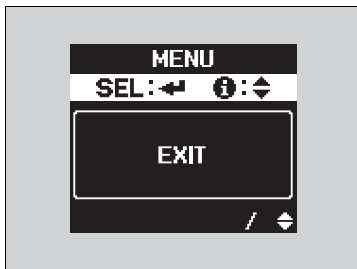

6. Press the / button until **TRIP A RESET with CHARGE** appears on the display, then press the **SEL/RESET** button.

▶ The display switches to the **SETUP** screen, where you can select **ON**, **OFF**, or **EXIT**.

7. Press the / button and select **ON**, then press the **SEL/RESET** button.

8. Press the / button until **EXIT** appears on the display, then press the **SEL/RESET** button.

9. Repeat Step 8 until you return to the normal screen.

## ■ Telematics Control Unit

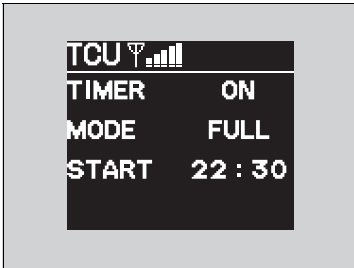

Sends and receives information between your vehicle and smartphones.

When you turn the power switch to LOCK [0], the telematics control unit signal strength and High Voltage battery charge timer setting appear on the multi-information display.

## ■ Trip Summary

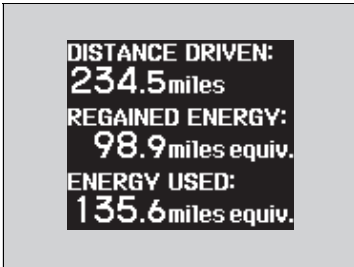

Shows the distance traveled in mile or km, the regenerated electric power, and the electricity consumption both in mile or km equivalent during your last trip when you turn the power switch to LOCK [0].

## ☒ Telematics Control Unit

If you are planning to use the smartphones, check the telematics control unit signal strength before leaving the vehicle.





# Controls

This chapter explains how to operate the various controls necessary for driving.



<b>Locking and Unlocking the Doors</b>		
Key Types and Functions .....	98	
Locking/Unlocking the Doors from the Outside .....	100	
Locking/Unlocking the Doors from the Inside .....	102	
Childproof Door Locks .....	103	
Auto Door Locking/Unlocking .....	104	
<b>Opening and Closing the Tailgate</b>		
Using the Tailgate Open Handle .....	106	
<b>Security System</b> .....	107	
Immobilizer System .....	107	
Security System Alarm .....	107	
<b>Opening and Closing the Windows</b> ...	109	
<b>Operating the Switches Around the Steering Wheel</b>		
Power Switch .....	111	
Turn Signals .....	112	
Light Switches .....	112	
Daytime Running Lights .....	113	
Wipers and Washers .....	114	
Brightness Control .....	116	
Rear Defogger Button .....	117	
Adjusting the Steering Wheel .....	118	
<b>Adjusting the Mirrors</b> .....	119	
Interior Rearview Mirror .....	119	
Power Door Mirrors .....	119	
<b>Adjusting the Seats</b> .....	120	
Adjusting the Seat Positions .....	120	
<b>Interior Lights/Interior Convenience Items</b> .....	126	
Interior Lights .....	126	
Interior Convenience Items .....	128	
<b>Climate Control System</b> .....	133	
Using Automatic Climate Control ....	133	
Automatic Climate Control Sensors ...	135	
<b>Interactive Remote</b> .....	136	
Error Code .....	139	

## Key Types and Functions

This vehicle comes with the following key:

### Keys

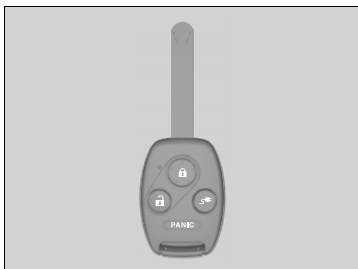

Use the key to turn on and off the power system, and to lock and unlock all the doors and tailgate. You can also use the remote transmitter to lock and unlock the doors and tailgate, and open the charge lid.

### Key Types and Functions

All the keys have an immobilizer system. The immobilizer system helps to protect against vehicle theft.

#### **Immobilizer System** P. 107

The keys contain precision electronics. Adhere to the following advice to prevent damage to the electronics:

- Do not leave the keys in direct sunlight, or in locations with high temperature or high humidity.
- Do not drop the keys or set heavy objects on them.
- Keep the keys away from liquids.
- Do not take the keys apart except for replacing the battery.

If the circuits in the keys are damaged, the power system may not turn on, and the remote transmitter may not work.

If the keys do not work properly, have them inspected by an authorized Honda Fit EV dealer.

## ■ Key Number Tag

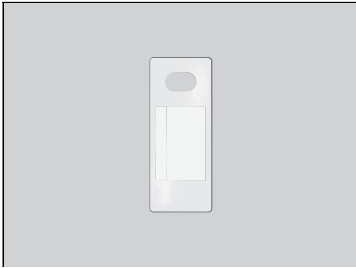

Contains a number that you will need if you purchase a replacement key.

## ▣ Key Number Tag

Keep the key number tag separate from the key in a safe place outside of a vehicle.  
If you wish to purchase an additional key, contact an authorized Honda Fit EV dealer.

If you lose your key and you cannot activate the power system, contact an authorized Honda Fit EV dealer.

## Locking/Unlocking the Doors from the Outside

### ■ Using the Remote Transmitter

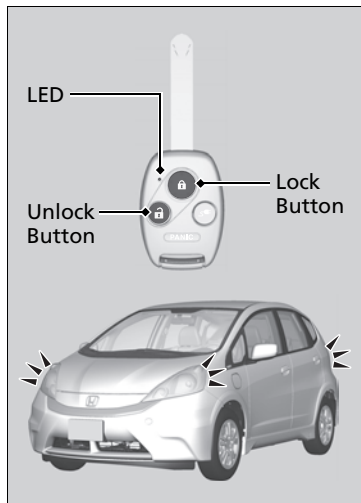

#### ■ Locking the doors

Press the lock button.

##### Once:

- ▶ Some exterior lights flash, all the doors and tailgate lock, and the security system sets.

##### Twice (within five seconds after the first push):

- ▶ The beeper sounds and verifies the security system is set.

#### ■ Unlocking the doors

Press the unlock button.

##### Once:

- ▶ Some exterior lights flash twice, and the driver's door unlocks.

##### Twice:

- ▶ The remaining doors and tailgate unlock.

### ▣ Using the Remote Transmitter

If you do not open a door within 30 seconds of unlocking the vehicle with the remote transmitter, the doors will automatically relock.

If the interior light switch is in the door activated position, the interior light comes on when you press the unlock button.

No doors opened: The light fades out after 30 seconds.

Doors relocked with the remote: The light goes off immediately.

The remote transmitter uses low-power signals, so the operating range may vary depending on the surroundings.

The remote will not lock the vehicle when a door or tailgate is open.

If the distance at which it works varies, the battery is probably low.

If the LED does not come on when you press a button, the battery is dead.

▣ **Replacing the Battery** P. 221

## ■ Locking/Unlocking the Doors Using a Key

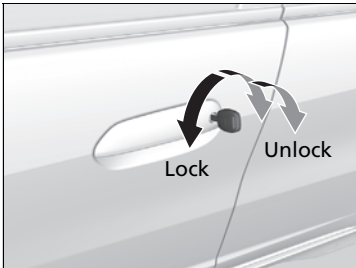

Fully insert the key and turn it.

## ■ Locking a Door Without Using a Key

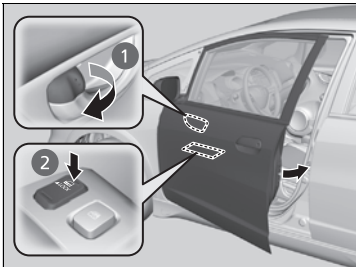

### ■ Locking the driver's door

Pull the lock tab rearward **1** or push the master door lock switch in the lock direction **2**, and close the door.

### ■ Locking the passenger's doors

Pull the lock tab rearward and close the door.

### ■ Lockout prevention system

The doors and the tailgate cannot be locked when the key is in the power switch, and any door or the tailgate is open.

### ☒ Locking/Unlocking the Doors Using a Key

When you lock the driver's door with a key, all of the other doors and tailgate lock at the same time. When unlocking, the driver's door unlocks first. Turn the key a second time within a few seconds to unlock the remaining doors and the tailgate.

### ☒ Locking a Door Without Using a Key

When you lock the driver's door, all the other doors and tailgate lock at the same time. Make sure you have the key in your hand before locking the door to prevent it from being locked in the vehicle.

## Locking/Unlocking the Doors from the Inside

### ■ Using the Lock Tab

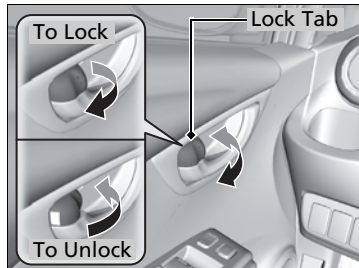

■ **Locking a door**  
Pull the lock tab rearward.

■ **Unlocking a door**  
Push the lock tab forward.

### ■ Using the Master Door Lock Switch

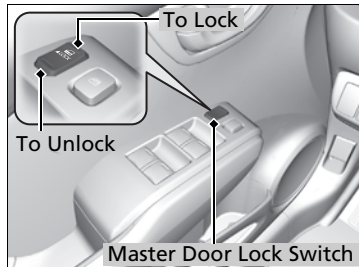

Press the master door lock switch in as shown to lock or unlock all doors and the tailgate.

### ☒ Using the Lock Tab

When you lock the door using the lock tab on the driver's door, all the other doors and tailgate lock at the same time.

When you unlock the door using the lock tab on the driver's door, only the driver's door will unlock.

### ☒ Using the Master Door Lock Switch

When you lock/unlock the driver's door and tailgate using the master lock switch, all the other doors lock/unlock at the same time.

## Childproof Door Locks

The childproof door locks prevent the rear doors from being opened from the inside regardless of the position of the lock tab.

### ■ Setting the Childproof Door Locks

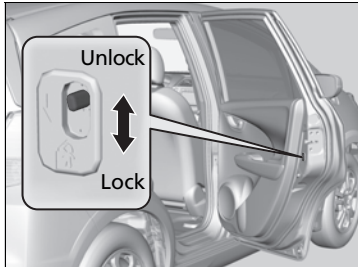

Slide the lever in the rear door to the lock position, and close the door.

### ■ When opening the door

Open the door using the outside door handle.

### ☒ Childproof Door Locks

To open the door from the inside when the childproof door lock is on, put the lock tab in the unlock position, lower the rear window, put your hand out of the window, and pull the outside door handle.



## Auto Door Locking/Unlocking

Your vehicle locks all doors and unlocks the driver's door automatically when a certain condition is met.

### ■ Auto Door Locking

#### ■ Drive lock mode

All doors lock when the vehicle's speed reaches about 10 mph (15 km/h).

### ■ Auto Door Unlocking

#### ■ Park unlock mode

The driver's door unlocks when the shift lever is moved into **P** with the brake pedal depressed.

### ☒ Auto Door Locking/Unlocking

You can turn off or change to another auto door locking/unlocking setting using the multi-information display.

☒ **Customized Features** P. 89

## Precautions for Opening/Closing the Tailgate

Always make sure individuals and objects are clear of the tailgate before opening or closing it.

### ■ Opening the tailgate

- Open the tailgate all the way.
  - ▶ If it is not fully opened, the tailgate may begin to close under its own weight.
- Be careful when it is windy. The wind may cause the tailgate to close.

### ■ Closing the tailgate

Keep the tailgate closed while driving to:

- ▶ Avoid possible damage.

### ⚠ Precautions for Opening/Closing the Tailgate

Be careful not to put your hands between the tailgate and the cargo area when closing the tailgate.

Do not allow any passenger in the cargo space. They may get hurt during hard braking, a sudden acceleration, or a crash.

## Using the Tailgate Open Handle

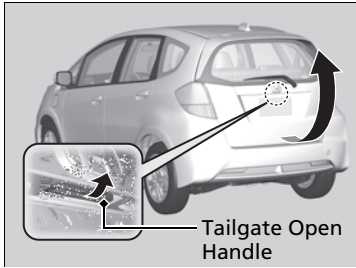

When all the doors are unlocked, the tailgate is unlocked.

Pull up the tailgate open handle and lift open the tailgate.

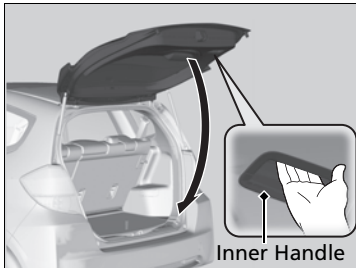

To close the tailgate, grab the inner handle, pull the tailgate down, and push it closed from outside.

## Immobilizer System

The immobilizer system prevents a key that has not been pre-registered from starting the motor. Each key contains electronic transmitters that use electronic signals to verify the key.

Pay attention to the following when inserting the key into the power switch:

- Do not allow objects that emit strong radio waves near the power switch.
- Make sure the key is not covered by or touching a metal object.
- Do not bring a key from another vehicle's immobilizer system near the power switch.

## Security System Alarm

The security system alarm activates when the tailgate, hood or doors are opened without the key, or remote transmitter.

### ■ When the security system alarm activates

The horn sounds intermittently and all the exterior lights flash.

### ■ To deactivate the security system alarm

Unlock the vehicle using the key or remote transmitter, or turning the power switch to ON **[II]**. The system, along with the horn and flashing lights, is deactivated.

### » Immobilizer System

#### NOTICE

Leaving the key in the vehicle can result in theft or accidental movement of the vehicle. Always take the key with you whenever you leave the vehicle unattended.

Do not alter the system or add other devices to it. Doing so may damage the system and make your vehicle inoperable.

### » Security System Alarm

The security alarm continues for a maximum of two minutes until the security system deactivates.

### ■ Setting the security system alarm

The security system alarm automatically sets when the following conditions have been met:

- The power switch is in LOCK [0], and the key has been removed from the power switch.
- The hood is closed.
- All doors and the tailgate are locked with the key or the remote transmitter.

### ■ When the security system alarm sets

The security system alarm indicator in the instrument panel blinks. When the blinking interval changes after about 15 seconds, the security system alarm is set.

### ■ To cancel the security system alarm

The security system alarm is canceled when the vehicle is unlocked using the key or remote transmitter, or the power switch is turned to ON [II]. The security system alarm indicator goes off at the same time.

## ■ Panic Mode

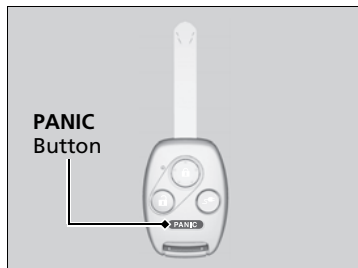

### ■ The PANIC button on the remote transmitter

If you press the **PANIC** button for approximately one second, the following will occur for about 30 seconds:

- The horn sounds.
- Some exterior lights flash.

### ■ Canceling panic mode

Press any button on the remote transmitter, or turn the power switch to ON [II].

## ⌘ Security System Alarm

Do not set the security system alarm when someone is in the vehicle or a window is open. The system can accidentally activate when unlocking the door with the lock tab.

If the 12 volt battery goes dead after you have set the security system alarm, the security alarm may go off once the 12 volt battery is recharged or replaced. If this occurs, deactivate the security system alarm by unlocking a door using the key or remote transmitter.

Do not attempt to alter this system or add another device to it.

## Opening/Closing the Power Windows

The power windows can be opened and closed when the power switch is in ON (II), using the switches on the doors. The driver's side switches can be used to open and close all of the windows.

The power window lock button on the driver's side must be switched off (not pushed in) to open and close the windows from anywhere other than the driver's seat.

When the power window lock button is pushed in, you can only operate the driver's window. Turn the power window lock button on when children are in the vehicle.

### Opening/Closing Windows with Auto-Open/Close Function

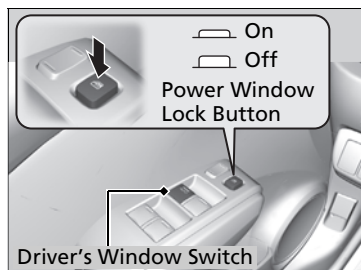

#### Automatic operation

**To open:** Push the switch down firmly.

**To close:** Pull the switch up firmly.

The window opens or closes completely. To stop the window at any time, push or pull the switch briefly.

#### Manual operation

**To open:** Push the switch down lightly.

**To close:** Pull the switch up lightly.

Release the switch when the window reaches the desired position.

### Opening/Closing the Power Windows

## ⚠ WARNING

Closing a power window on someone's hands or fingers can cause serious injury.

Make sure your passengers are away from the windows before closing them.

The power windows can be operated for up to 10 minutes after you turn the power switch off. Opening either front door cancels this function.

#### Auto Reverse

If a power window senses resistance when closing automatically, it will stop closing and reverse direction.

The driver's window auto reverse function is disabled when you continuously pull up the switch.

The auto reverse function stops sensing when the window is almost closed to ensure that it fully closes.

## ■ Opening/Closing Windows without Auto-Open/Close Function

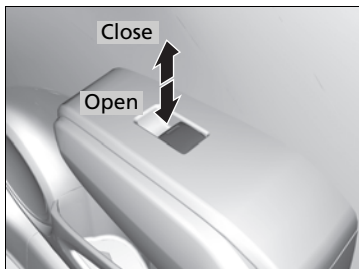

**To open:** Push the switch down.

**To close:** Pull the switch up.

Release the switch when the window reaches the desired position.

## Power Switch

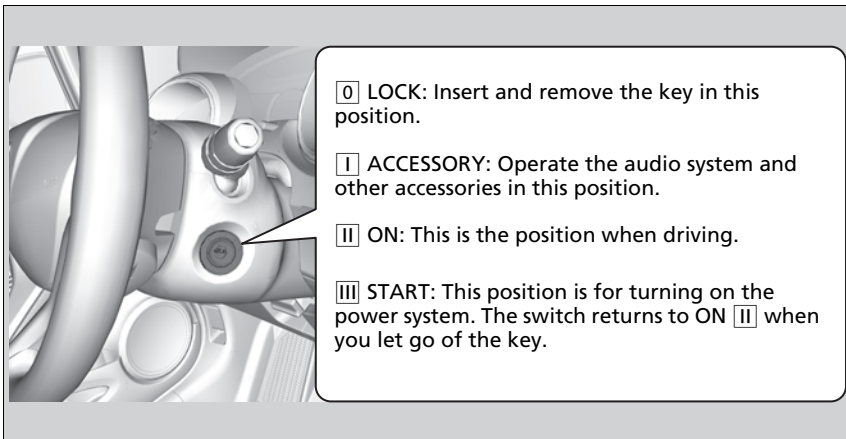

### Power Switch

You cannot take the key out unless the shift lever is in **P**.

If you open the driver's door when the key is in LOCK **0** or ACCESSORY **I**, a warning buzzer will sound to remind you to take the key out.

When this happens, the following messages appear on the multi-information display:

- In LOCK **0**: **REMOVE KEY**
- In ACCESSORY **I**: **RETURN IGNITION SWITCH TO LOCK (0) POSITION**

If the key won't turn from LOCK **0** to ACCESSORY **I**, turn the key while moving the steering wheel left and right. The steering wheel will unlock, allowing the key to turn.

The 12 volt battery cannot be charged unless the power system is on.



## Turn Signals

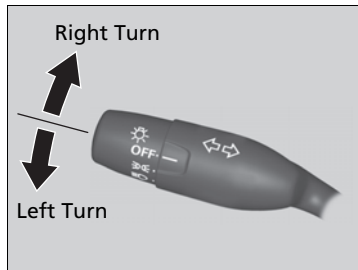

The turn signals can be used when the power switch is in ON **II**.

## Light Switches

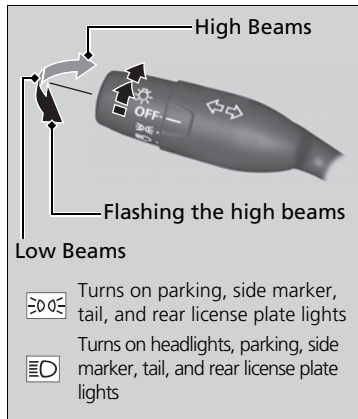

Rotating the light switch turns the lights on and off, regardless of the position of the power switch.

### ■ High beams

Push the lever forward until you hear a click.

### ■ Low beams

When in high beams, pull the lever back to return to low beams.

### ■ Flashing the high beams

Pull the lever back, and release it.

### ⊗ Light Switches



If you remove the key from the power switch while the lights are on, a chime sounds when the driver's door is opened.

Do not leave the lights on when the power system is off, because it will cause the 12 volt battery to discharge.

## Daytime Running Lights

---

The high beam headlights come on slightly dimmer than normal when the following conditions have been met:

- The power switch is in ON .
- The headlight switch is off, or in .
- The parking brake is released.

The lights remain on even if you set the parking brake. Turning off the power switch will turn off the daytime running lights.

The high beam headlights return to the original brightness once the headlight switch is turned on.

## Wipers and Washers

### ■ Front Wiper/Washer

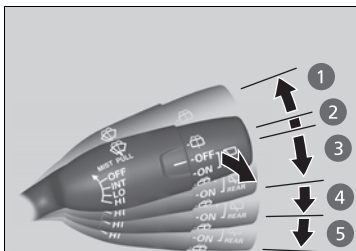

- 1 **MIST**
- 2 **OFF**
- 3 **INT:** Low speed with intermittent
- 4 **LO:** Low speed wipe
- 5 **HI:** High speed wipe

The windshield wipers and washers can be used when the power switch is in ON **II**.

#### ■ MIST

The wipers run at high speed until you release the lever.

#### ■ Wiper switch (OFF, INT, LO, HI)

Change the wiper switch setting according to the amount of rain.

#### ■ Washer

Sprays while you pull the lever toward you.

When you release the lever, the wipers make two or three more sweeps before stopping.

### » Wipers and Washers

#### NOTICE

Do not use the wipers when the windshield is dry. The windshield will get scratched, or the rubber blades will get damaged.

#### NOTICE

In cold weather, the blades may freeze to the windshield, becoming stuck. Operating the wipers in this condition may damage the wipers. Use the defroster to warm the windshield, then turn the wipers on.

Turn the washers off if no washer fluid comes out. The pump may get damaged.

If the wiper stops operating due to any obstacle such as the build-up of snow, park the vehicle in a safe place.

Rotate the wiper switch to **OFF**, and turn the power switch to ACCESSORY **I** or LOCK **0**, then remove the obstacle.

The wiper motor is equipped with a breaker that may stop motor operation temporarily to prevent an overload. Wiper operation will return to normal within a few minutes, once the circuit has returned to normal.

## ■ Rear Wiper/Washer

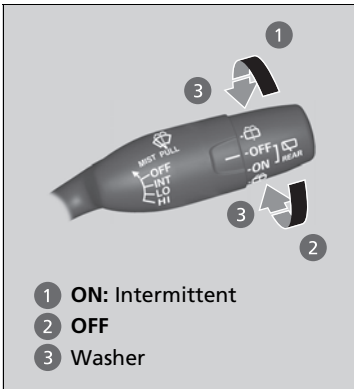

The rear wiper and washer can be used when the power switch is in ON **II**.

### ■ Wiper switch (OFF, ON)

The wiper operates intermittently after completing a few sweeps.

### ■ Washer (Washer symbol)

Sprays while you rotate the switch to this position.

Hold it to activate the wiper and to spray the washer. Once released, it stops operating after a few more sweeps.

### ■ Operating in reverse

When you shift the transmission to **R** with the front wiper activated, the rear wiper operates automatically as follows even if its switch is off.

Front Wiper Position	Rear Wiper Operation
<b>INT</b> (Intermittent)	Intermittent
<b>LO</b> (Low speed wipe) <b>HI</b> (High speed wipe)	Continuous

## Brightness Control

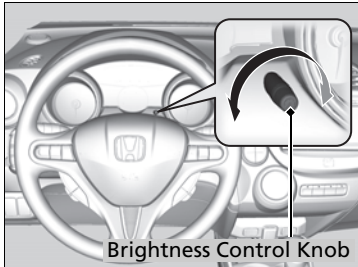

When the exterior lights are turned on and the power switch is in ON **II**, you can use the brightness control knob to adjust instrument panel brightness.

**Brighten:** Turn the knob to the right.

**Dim:** Turn the knob to the left.

You will hear a beep when the brightness reaches minimum or maximum. The multi-information display will return to its original state several seconds after you adjust the brightness.

### ■ Brightness level indicator

The brightness level is shown on the multi-information display while you are adjusting it.

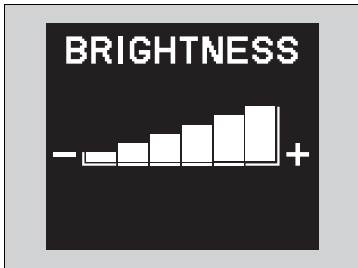

### ▶▶ Brightness Control

If you turn the knob to the right until the brightness display is up to max, the beeper sounds. This cancels the reduced instrument panel brightness when the exterior lights are on.

## Rear Defogger Button

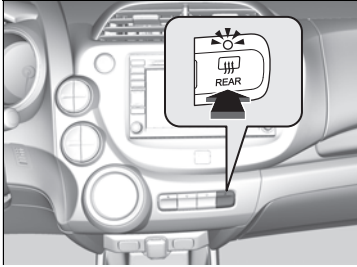

Press the rear defogger button to defog the rear window when the power switch is in ON .

The rear defogger automatically switches off after 10-30 minutes depending on the outside temperature. However, if the outside temperature is 32°F (0°C) or below, it does not automatically switch off.

### Rear Defogger Button

#### NOTICE

When cleaning the inside of the rear window, be careful not to damage the heating wires. It is critical to wipe the window from side to side along the defogger heating wires.

This system consumes a lot of power, so turn it off when the window has been defogged. Also, do not use the system for a long period when the power system is off. This may weaken the 12 volt battery, making it difficult to turn the power system on.

## Adjusting the Steering Wheel

The steering wheel height and distance from your body can be adjusted so that you can comfortably grip the steering wheel in an appropriate driving posture.

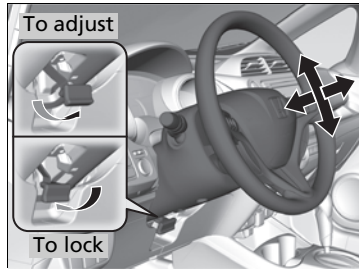

1. Pull the steering wheel adjustment lever up.
  - The steering wheel adjustment lever is under the steering column.
2. Move the steering wheel up or down, and in or out.
  - Make sure you can see the instrument panel gauges and indicators.
3. Push the steering wheel adjustment lever down to lock the steering wheel in position.
  - After adjusting the position, make sure you have securely locked the steering wheel in place by trying to move it up, down, in, and out.

### Adjusting the Steering Wheel

#### **WARNING**

Adjusting the steering wheel position while driving may cause you to lose control of the vehicle and be seriously injured in a crash.

Adjust the steering wheel only when the vehicle is stopped.

Make any steering wheel adjustments before you start driving.

# Adjusting the Mirrors

## Interior Rearview Mirror

Adjust the angle of the rearview mirror when you are sitting in the correct driving position.

### Rearview Mirror with Day and Night Positions

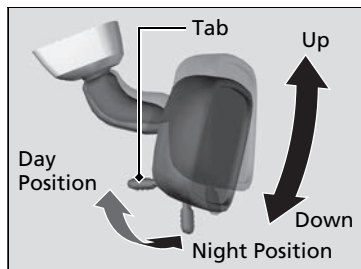

Flip the tab to switch the position. The night position will help to reduce the glare from headlights behind you when driving after dark.

## Power Door Mirrors

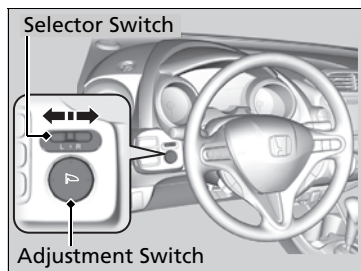

You can adjust the door mirrors when the power switch is in ON **II**.

### Mirror position adjustment

**L/R selector switch:** Select the left or right mirror. After adjusting the mirror, return the switch to the center position.

**Mirror position adjustment switch:** Press the switch left, right, up, or down to move the mirror.

### Adjusting the Mirrors

Keep the inside and outside mirrors clean and adjusted for best visibility.

Adjust the mirrors before you start driving.

➤ **Adjusting the Seat Positions** P. 120

### Power Door Mirrors

You can manually fold or unfold the mirrors while the power switch is in LOCK **0** or ACCESSORY **I**.



## Adjusting the Seat Positions

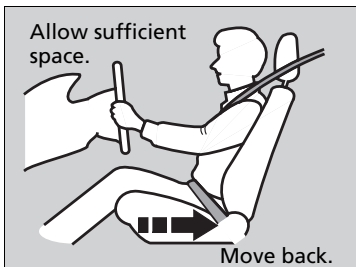

Adjust the driver's seat as far back as possible while allowing you to maintain full control of the vehicle. You should be able to sit upright, well back in the seat and be able to adequately press the pedals without leaning forward, and grip the steering wheel comfortably. The passenger's seat should be adjusted in a similar manner, so that it is as far back from the front airbag in the dashboard as possible.

### ■ Adjusting the front seat

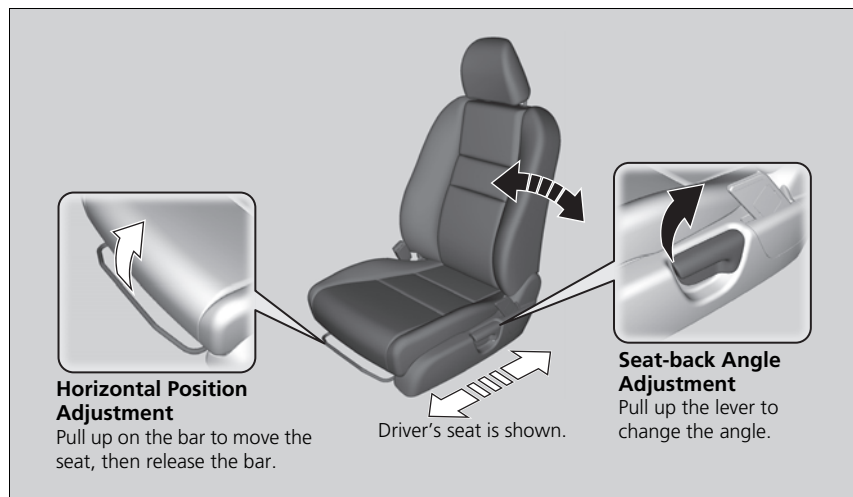

### ⌘ Adjusting the Seats

## **⚠ WARNING**

**Sitting too close to a front airbag can result in serious injury or death if the front airbags inflate.**

**Always sit as far back from the front airbags as possible while maintaining control of the vehicle.**

The National Highway Traffic Safety Administration and Transport Canada recommend that drivers allow at least 10 inches (25 cm) between the center of the steering wheel and the chest.

Always make seat adjustments before driving.

### ⌘ Adjusting the front seat

Once a seat is adjusted correctly, rock it back and forth to make sure it is locked in position.

## ■ Adjusting the Seat-Backs

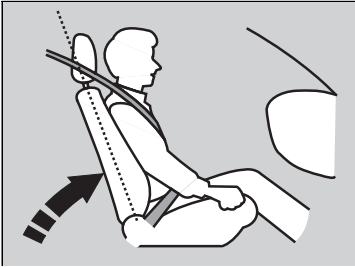

Adjust the driver's seat-back to a comfortable, upright position, leaving ample space between your chest and the airbag cover in the center of the steering wheel.

The front seat passenger should also adjust their seat-back to a comfortable, upright position.

Reclining a seat-back so that the shoulder part of the belt no longer rests against the occupant's chest reduces the protective capability of the belt. It also increases the chance of sliding under the belt in a crash and being seriously injured. The farther a seat-back is reclined, the greater the risk of injury.

## ▣ Adjusting the Seat-Backs

### ⚠ WARNING

Reclining the seat-back too far can result in serious injury or death in a crash.

Adjust the seat-back to an upright position, and sit well back in the seat.

Do not put a cushion, or other object, between the seat-back and your back.

Doing so may interfere with proper seat belt or airbag operation.

If you cannot get far enough away from the steering wheel and still reach the controls, we recommend that you investigate whether some type of adaptive equipment may help.

## ■ Adjusting the Head Restraints

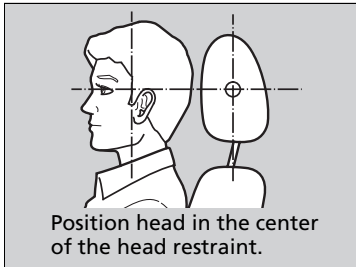

Your vehicle is equipped with head restraints in all seating positions.

Head restraints are most effective for protection against whiplash and other rear-impact crash injuries when the center of the back of the occupant's head rests against the center of the restraint. The tops of the occupant's ears should be level with the center height of the restraint.

## ■ Adjusting the front head restraint positions

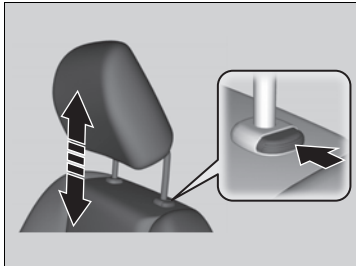

**To raise the head restraint:** Pull it upward.

**To lower the head restraint:** Push it down while pressing the release button.

## ►► Adjusting the Head Restraints

### **⚠ WARNING**

Improperly positioning head restraints reduces their effectiveness and increases the likelihood of serious injury in a crash.

**Make sure head restraints are in place and positioned properly before driving.**

The driver's and front passenger's seats have active head restraints.

► **Active Head Restraints** P. 124

## ■ Changing the Rear Seat Head Restraint Positions

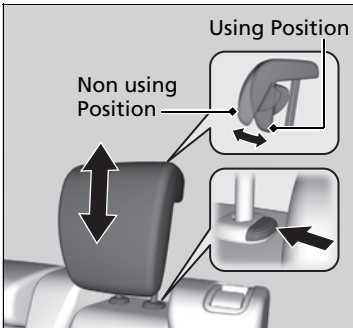

A passenger sitting in a back seating position should adjust the height of their head restraint to an appropriate position before the vehicle begins moving.

### To raise the head restraint:

1. Pull it upward.

#### Rear outer head restraint

2. Push back the front side of the head restraint.

### To lower the head restraint:

#### Rear outer head restraint

1. Pull up the front side of the head restraint.

#### All rear head restraints

2. Push it down while pressing the release button.

## ■ Removing and Reinstalling the Head Restraints

Head restraints can be removed for cleaning or repair.

### To remove a head restraint:

Pull the restraint up as far as it will go. Then push the release button, and pull the restraint up and out.

### To reinstall a head restraint:

Insert the legs back in place, then adjust the head restraint to an appropriate height while pressing the release button. Pull up on the restraint to make sure it is locked in position.

### ✕ Removing and Reinstalling the Head Restraints

## ⚠ WARNING

Failure to reinstall, or correctly reinstall, the head restraints can result in severe injury during a crash.

Always replace the head restraints before driving.

Continued

## ■ Active Head Restraints

The driver's and front passenger's seats have active head restraints. In a rear impact, an occupant properly secured by a seat belt will be pushed against the seat-back and the head restraint will move forward. This reduces the distance between the restraint and the occupant's head, which helps reduce the likelihood of whiplash and injuries to the neck and upper spine.

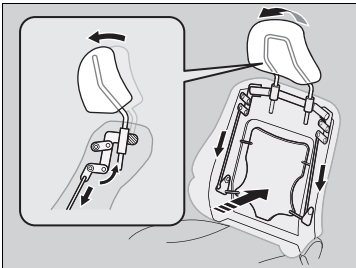

## ■ Maintain a Proper Sitting Position

After all occupants have adjusted their seats and head restraints, and put on their seat belts, it is very important that they continue to sit upright, well back in their seats, with their feet on the floor, until the vehicle is safely parked and the power system is off.

Sitting improperly can increase the chance of injury during a crash. For example, if an occupant slouches, lies down, turns sideways, sits forward, leans forward or sideways, or puts one or both feet up, the chance of injury during a crash is greatly increased.

In addition, an occupant who is out of position in the front seat can be seriously or fatally injured in a crash by striking interior parts of the vehicle or being struck by an inflating front airbag.

## ⌘ Active Head Restraints

In order for the active head restraints to operate properly:

- Do not hang any items on the head restraints, or from the restraint legs.
- Do not place any objects between an occupant and the seat-back.
- Install each restraint in its proper location.

After a collision, the activated restraint should return to its normal position. If the restraint does not return to its normal position, or in the event of a severe collision, have the vehicle inspected by an authorized Honda Fit EV dealer.

## ⌘ Maintain a Proper Sitting Position

### **⚠ WARNING**

**Sitting improperly or out of position can result in serious injury or death in a crash.**

**Always sit upright, well back in the seat, with your feet on the floor.**

## Rear Seats

### Folding Down the Rear Seats

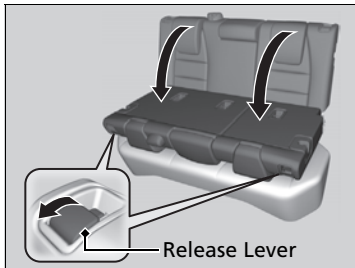

Pull the release lever and fold down the seat-back.

## Armrest

### Using the Driver's Seat Armrest



Pull down the armrest.

### Folding Down the Rear Seats

The rear seat-backs can be folded down to accommodate bulkier items in the cargo area.

**Make sure all items in the cargo area or items extending to the rear seats are properly secured. Loose items can fly forward if you have to brake hard.**

To lock a seat-back upright, push it backwards until it locks. When returning a seat-back to its original position, push it firmly back. Also, make sure all rear shoulder belts are positioned in front of the seat-back.

Make sure that the folded seat-back does not press against the front passenger seat, as this can cause the front passenger seat weight sensor to work improperly.

▶ Side Airbag Off Indicator P. 54

## Interior Lights

### Interior Light Switch

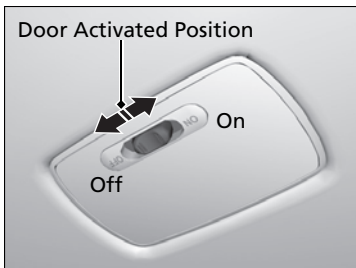

#### ■ ON

The interior light comes on regardless of whether the doors are open or closed.

#### ■ Door activated

The interior light comes on in the following situations:

- When any of the doors are opened.
- You unlock the driver's door.
- You remove the key from the power switch.

#### ■ OFF

The interior light remains off regardless of whether the doors are open or closed.

### Interior Light Switch

In the door activated position, the interior light fades out and goes off about 30 seconds after the doors are closed.

The light goes off after 30 seconds in the following situations:

- When you unlock the driver's door but do not open it.
- When you remove the key from the power switch but do not open a door.

The interior light goes off immediately in the following situations:

- When you lock the driver's door.
- When you close the driver's door with the key in the power switch.
- When you turn the power switch to ON **II**.

If you leave any of the doors open without the key in the power switch, the interior light goes off after about 15 minutes.

### Map Lights

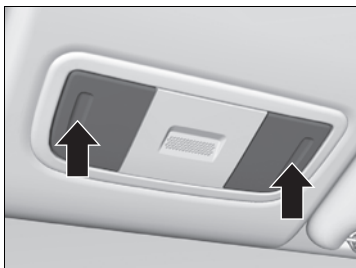

The map lights can be turned on and off by pressing the lenses.

## ■ Cargo Area Light

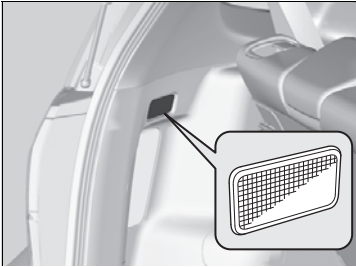

The light comes on when you open the tailgate.



## Interior Convenience Items

### ■ Glove Box

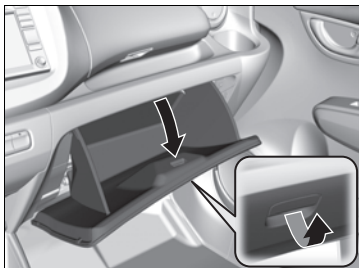

Pull the handle to open the glove box.

### ■ Upper Glove Box

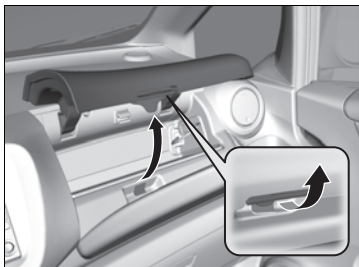

Pull up on the lever to open the upper glove box.

### ☒ Glove Box

#### **⚠ WARNING**

An open glove box can cause serious injury to your passenger in a crash, even if the passenger is wearing the seat belt.

Always keep the glove boxes closed while driving.

## ■ Beverage Holders

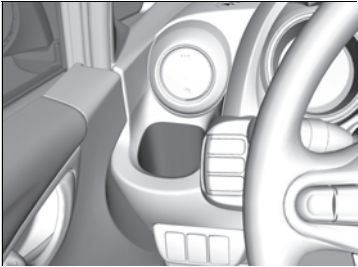

### ■ Front seat beverage holders

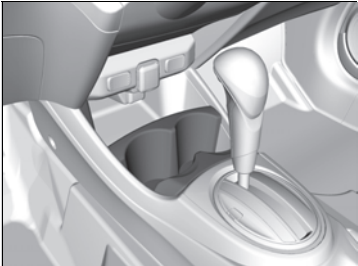

### ■ Rear seat beverage holders

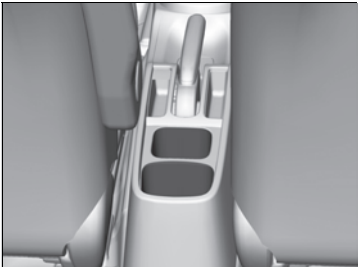

## » Beverage Holders

### NOTICE

Spilled liquids can damage the upholstery, carpeting, and electrical components in the interior.

Be careful when you are using the beverage holders. Hot liquid can scald you.

### ■ Cargo Floor Box

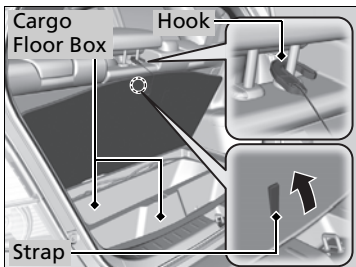

Pull up the strap and open the cargo area floor lid.

### ■ Accessory Power Socket

The accessory power socket can be used when the power switch is in ACCESSORY **I** or ON **II**.

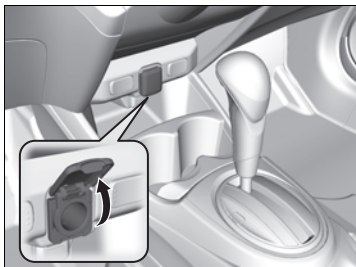

Open the cover to use it.

### ▣ Cargo Floor Box

To keep the cargo floor lid open, hook the strap on the rear center head restraint leg.

### ▣ Accessory Power Socket

#### NOTICE

Do not insert an automotive type cigarette lighter element. This can overheat the power socket.

#### NOTICE

Do not operate the tire repair kit compressor for more than 15 minutes. The accessory power socket and compressor can overheat and become permanently damaged.

The accessory power socket is designed to supply power for 12 volt DC accessories that are rated 180 watts or less (15 amps).

To prevent 12 volt battery drain, only use the power socket with the power system on.

## ■ Coat Hook

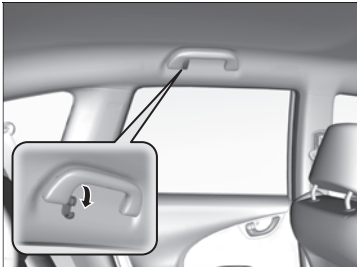

There is a coat hook on the rear left grab handle. Pull it down to use it.

## ☒ Coat Hook

The coat hook is not designed for large or heavy items.

## Seat Heaters



The power switch must be in ON **II** to use the seat heaters. The **HI** setting heats the seats faster than the **LO** setting.

There is no heater in the passenger's seat-back due to the side airbag cutoff system.

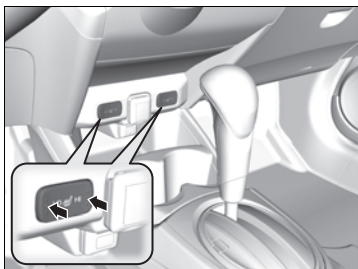

While in **HI**, the heater cycles on and off.

- The appropriate indicator will be on while the seat heater is on. Briefly press the switch on the opposite side to turn the heater off. The indicator will be off. When a comfortable temperature is reached, select **LO** to keep the seat warm.

## Seat Heaters

### **WARNING**

Heat induced burns are possible when using seat heaters.

Persons with a diminished ability to sense temperature (e.g., persons with diabetes, lower-limb nerve damage, or paralysis) or with sensitive skin should not use seat heaters.

Do not use the seat heaters even in **LO** when the power system is off. Under such conditions, the 12 volt battery may be weakened, making the power system difficult to start.

In the **LO** setting, the heater runs continuously and does not automatically turn off.

## Using Automatic Climate Control

The automatic climate control system maintains the interior temperature you select. The system also raises or lowers the interior temperature to your preference as quickly as possible.

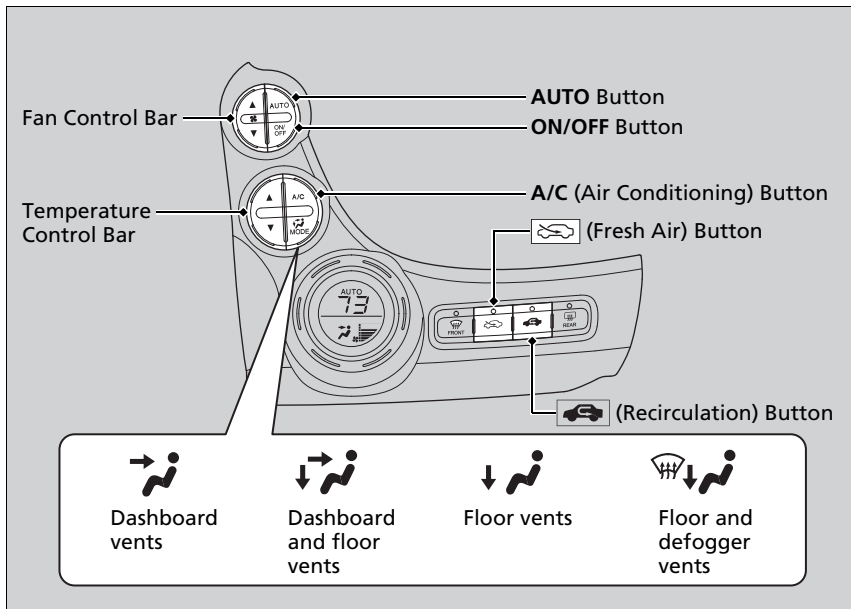

Use the system when the power system is on.

1. Press the **AUTO** button.
2. Adjust the interior temperature using the temperature control bar.
3. Press the **ON/OFF** button to cancel.

### Using Automatic Climate Control

If any buttons are pressed while using the climate control system in **AUTO**, the function of the button that was pressed will take priority.

The **AUTO** indicator will go off, but functions unrelated to the button that were pressed will be controlled automatically.

To prevent cold air from blowing in from outside, the fan may not start immediately when the **AUTO** button is pressed.



If the interior is very warm, you can cool it down more rapidly by partially opening the windows, turning the system on **AUTO**, and setting the temperature to low. Change the fresh mode to recirculation mode until the temperature cools down.

When you set the temperature to the lower or upper limit, **Lo** or **Hi** is displayed.

Pressing the **ON/OFF** button switches the climate control system between on and off. When turned on, the system returns to your last selection.

While in the **ECON** mode, the climate control system has greater temperature fluctuations.

### ■ Switching between the recirculation and fresh air modes

Press the  (recirculation) or the  (fresh air) button and switch the mode depending on environmental conditions.

Recirculation Mode: Recirculates air from the vehicle's interior through the system.

Fresh Air Mode: Maintains outside ventilation. Keep the system in fresh air mode in normal situations.

### ■ Defrosting the Windshield and Windows

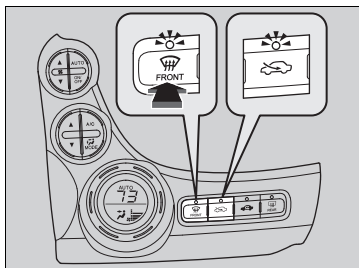

Pressing the  (windshield defroster) button turns the air conditioner system on and automatically switches the system to fresh air mode.

Press the  button again to turn off, the system returns to the previous settings.

### ■ To rapidly defrost the windows

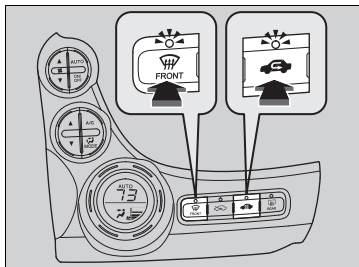

1. Press the  button.
2. Press the  button.

### ►► Defrosting the Windshield and Windows

**For your safety, make sure you have a clear view through all the windows before driving.**

Do not set the temperature near the upper or lower limit.

When cold air hits the windshield, the outside of the windshield may fog up.

If the side windows fog up, adjust the vents so that the air hits the side windows.

### ►► To rapidly defrost the windows

After defrosting the windows, switch over to fresh air mode.

If you keep the system in recirculation mode, the windows may fog up from humidity. This impedes visibility.

## Automatic Climate Control Sensors

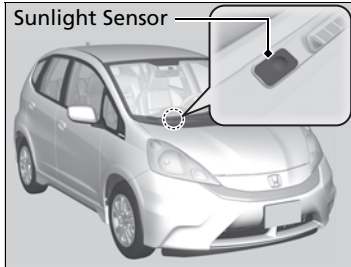

The automatic climate control system is equipped with a sunlight sensor, an interior temperature and humidity sensor. Do not cover or spill any liquid on them.

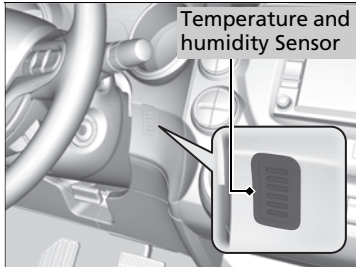



# Interactive Remote

The display on the interactive remote control can show the remaining High Voltage battery charge level percentage, the interior temperature, the High Voltage battery charging status, and other information. You can also start or stop the High Voltage battery charge and turn the climate control system on and off using this remote.

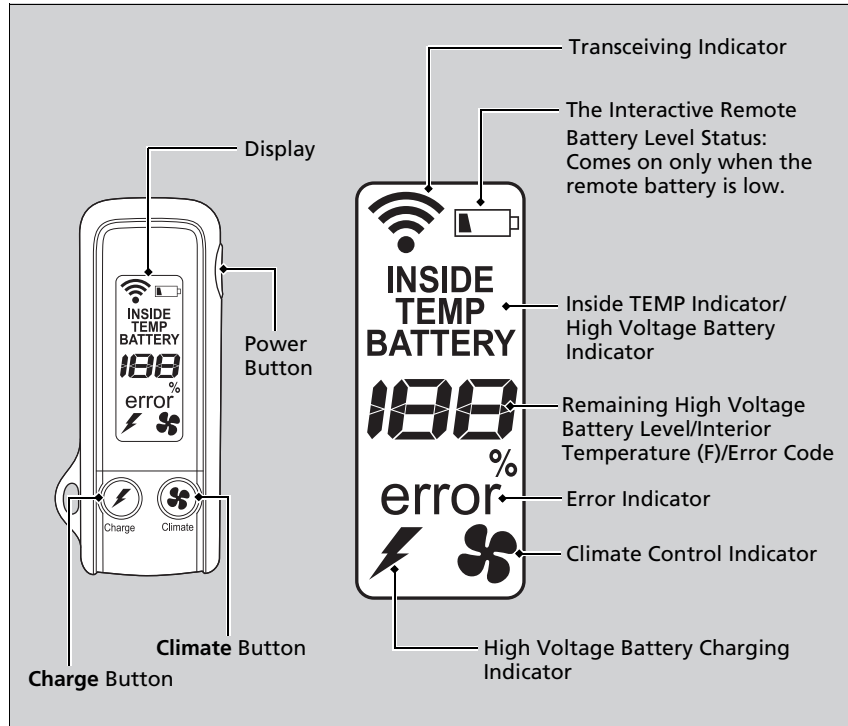

## Interactive Remote

Operate the remote in an open space. If there are buildings and obstacles between your vehicle and the remote, it works from around 100 feet to the vehicle. This distance may vary by external electrical interference.

The interactive remote contains precision electronics. Adhere to the following advice to prevent damage to the electronics:

- Do not leave the remote in direct sunlight, or in locations with high temperature or high humidity.
- Do not drop the remote or set heavy objects on it.
- Keep the keys away from liquids.
- Do not take the remote apart except for replacing the battery.

## ■ Turning on the Interactive Remote Control

Press the power button to turn on the remote. The beeper sounds once after the remote has received the information.

- ▶ The remote starts receiving information from the vehicle, the information includes:
  - Remaining High Voltage battery charge level percentage
  - Interior temperature in Fahrenheit
  - High Voltage battery charging status
    - ▶ While the High Voltage battery is being charged, the charging indicator blinks.
  - Climate control system status
    - ▶ While the climate control system is in use, the climate control indicator blinks.

## ■ Switching the display

Press the power button again to switch the display from remaining High Voltage battery level to the interior temperature.



## ■ Turning off the remote

Press and hold the power button. The power goes off automatically if you do not operate the remote for more than 15 seconds.

## ☒ Turning on the Interactive Remote Control

The transeiving indicator and error indicator blink simultaneously when the remote is not receiving signals from the vehicle. Find a place where signals coming from the vehicle are not blocked. The remote is more likely to receive signals when you hold up around your shoulder level in the upright position.

When you check your vehicle status using the interactive remote control or smartphone app, the navigation system comes on, performs a system checkup, and goes into standby mode. It automatically shuts off after a while.

If you want to operate the system while it is in standby mode, turn the power switch to ACCESSORY  or ON .

The temperature lower than 15°F remains displayed as **15**.

## ■ Charging the High Voltage Battery using the Remote

1. Make sure the charge connector is plugged in.
2. Press the power button to turn on the interactive remote.
3. Press and hold the **Charge** button.
  - ▶ The beeper sounds once.
  - ▶ The vehicle starts charging the High Voltage battery. The High Voltage battery charging indicator blinks. The charge stops when the High Voltage battery level is full.

## ■ Turning on the Climate Control System

Adjusting the interior temperature to the comfortable level of 77°F while the High Voltage battery is being charged can help reduce the battery use while driving.

1. Press the power button to turn on the interactive remote.
2. Press and hold the **Climate** button.
  - ▶ The beeper sounds once.
  - ▶ The climate control system turns on. The climate control indicator blinks.

## ■ Muting the Beeper Sounds

You can mute the beeper sounds that operate on the remote.

1. Press the power button to turn on the interactive remote.
2. Press and hold the power and **Charge** buttons at the same time.
  - ▶ To unmute the beeper sounds, press and hold the power and **Climate** buttons at the same time.
  - ▶ A chime sounds when the beeper sounds are muted or unmuted.

### ☒ Charging the High Voltage Battery using the Remote

Pressing and holding the **Charge** button again stops the High Voltage battery charging.

### ☒ Turning on the Climate Control System

The climate control system cannot be turned on when:

- The tailgate, hood, or any doors are open
- The key is in the power switch
- The brake pedal is depressed.

The climate control system may not be turned on if the interior and outside ambient temperatures are within certain parameters.

Pressing and holding the **Climate** button again turns off the climate control system.

The climate control system is automatically turned off when:

- If it is continuously on for 30 minutes.
- When the High Voltage battery level goes down to 15% or lower.
- The driver door or hood is open.
- The brake pedal is depressed.

If the charge connector is unplugged, the battery is used to power the climate control system.

If you are using the 120V (level 1) charge, you cannot turn on the climate control system remotely while the charge connector and the charging cable are plugged in.

## Error Code

If an error code appears on the display while operating the remote, refer to the table and take appropriate action.

Error Code	Problem/Explanation	What to Do
00	The remote or the vehicle's telecommunication device may have malfunctioned.	Consult an authorized Honda Fit EV dealer.
C0		
C9		
A0		
A9		
C1	The High Voltage battery charge failed to start.	Make sure the charging cable is plugged in.
C2		Make sure that you have removed the key from the power switch.
C3		Follow the C1 and C2 solutions while the shift lever is in <b>P</b> . If the error code still does not disappear, consult an authorized Honda Fit EV dealer.
C5	The High Voltage battery charge did not finish by the set charging time.	Release the charge connector from the vehicle, and consult an authorized Honda Fit EV dealer.
A1	The climate control system did not turn on.	The climate control system does not turn on when the High Voltage battery level is less than 15%. Charge the High Voltage battery first.
A2		Make sure that the hood and the doors are closed, and the key is removed from the power switch.
A3		Follow the A1 and A2 solutions. If the error code still does not disappear, consult an authorized Honda Fit EV dealer.
A4		The climate control system did not turn off. Consult an authorized Honda Fit EV dealer.



# Features

This chapter describes how to operate technology features.



## **Audio System**

About Your Audio System ..... 142

## About Your Audio System

---

See the Navigation System Manual for operation of the audio system, *Bluetooth*<sup>®</sup> HandsFreeLink<sup>®</sup>, and voice commands for these features.



# Driving

This chapter discusses driving, refueling, and information on items such as accessories.

## Before Driving

Driving Preparation .....	144
Maximum Load Limit.....	147

## When Driving

Turning on the Power .....	150
Precautions While Driving.....	152
Transmission .....	152
Shifting .....	153
3-Mode Drive System .....	155
Acoustic Vehicle Alerting System.....	156
Cruise Control .....	157
VSA® (Vehicle Stability Assist), aka ESC (Electronic Stability Control), System..	160

TPMS (Tire Pressure Monitoring System)..	162
Tire Pressure Monitoring System (TPMS) - Required Federal Explanation.....	163

## Braking

Brake System .....	165
ABS (Anti-lock Brake System) .....	167
Brake Assist System.....	168

## Parking Your Vehicle

When Stopped.....	169
-------------------	-----

## Rearview Camera

About Your Rearview Camera .....	170
----------------------------------	-----

## Charging

Before Charging .....	171
-----------------------	-----

Charge the High Voltage battery using a Level 1 or 2 charger .....	172
Control Box .....	177
High Voltage Battery.....	181
Using a Timer .....	182

## Energy Economy

Improving Energy Economy.....	184
-------------------------------	-----

## Modifications

Modifications.....	185
--------------------	-----



## Driving Preparation

Check the following items before you start driving.

### Exterior Checks

- Make sure there are no obstructions on the windows, door mirrors, exterior lights, or other parts of the vehicle.
  - ▶ Remove any frost, snow, or ice.
  - ▶ Remove any snow on the roof, as this can slip down and obstruct your field of vision while driving. If frozen solid, remove ice once it has softened.
  - ▶ When removing ice from around the wheels, be sure not to damage the wheel or wheel components.
- Make sure the hood is securely closed.
  - ▶ If the hood opens while driving, your front view will be blocked.
- Make sure the tires are in good condition.
  - ▶ Check air pressure, and check for damage and excessive wear.
    - ✎ **Checking and Maintaining Tires** P. 211
- Make sure there are no people or objects behind or around the vehicle.
  - ▶ There are blind spots from the inside.
- Disconnect the charging cable.

### Exterior Checks

#### NOTICE

When doors are frozen shut, use warm water around the door edges to melt any ice. Do not try to force them open, as this can damage the rubber trim around the doors. When done, wipe dry to avoid further freezing.

Do not pour warm water into the key cylinder. You will be unable to insert key if the water freezes in the hole.

Heat from the power system can ignite flammable materials left under the hood, causing a fire. If you've parked your vehicle for an extended period, inspect and remove any debris that may have collected, such as dried grass and leaves that have fallen or have been carried in for use as a nest by a small animal. Also check under the hood for leftover flammable materials after you or someone else has performed maintenance on your vehicle.

## Interior Checks

- Store or secure all items on board properly.
  - ▶ Carrying too much cargo, or improperly storing it, can affect your vehicle's handling, stability, stopping distance, and tires, and make it unsafe.
    - ✦ **Maximum Load Limit** P. 147
- Do not pile items higher than the seat height.
  - ▶ They can block your view and may be thrown forward in the event of sudden braking.
- Do not place anything in the front seat footwells. Make sure to secure the floor mat.
  - ▶ An object or unsecured floor mat can interfere with your brake and accelerator pedal operation while driving.
- If you have any animals on board, do not let them move around in the vehicle.
  - ▶ They may interfere with driving and a crash could occur.
- Securely close and lock all doors and the tailgate.
  - ✦ **Locking/Unlocking the Doors from the Inside** P. 102
- Adjust your seating position properly.
  - ▶ Adjust the head restraint, too.
    - ✦ **Adjusting the Seats** P. 120
    - ✦ **Adjusting the Head Restraints** P. 122
- Adjust the mirrors and steering wheel properly for your driving.
  - ▶ Adjust them while sitting in the proper driving position.
    - ✦ **Adjusting the Mirrors** P. 119
    - ✦ **Adjusting the Steering Wheel** P. 118

## Interior Checks

The headlight aim is set by the factory, and does not need to be adjusted. However, if you regularly carry heavy items in the cargo area, have the aiming readjusted at an authorized Honda Fit EV dealer or by a qualified technician.

- Be sure items placed on the floor behind the front seats cannot roll under the seats.
  - ▶ They can interfere with the driver's ability to operate the pedals, the operation of the seats, or the operation of the sensors under the seats.
- Everyone in the vehicle must fasten their seat belt.
  - 📄 **Fastening a Seat Belt** P. 37
- Make sure that the indicators in the instrument panel come on when you start the vehicle, and go off soon after.
  - ▶ Always have an authorized Honda Fit EV dealer check the vehicle if a problem is indicated.
    - 📄 **Indicators** P. 70

## Maximum Load Limit

The maximum load for your vehicle is 850 lbs (385 kg). See Tire and Loading Information label attached to the driver's doorjamb.

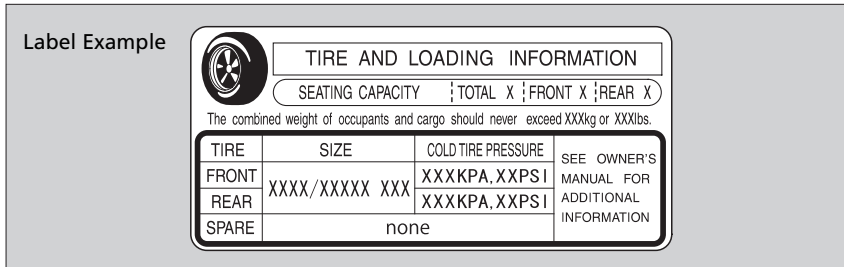

This figure includes the total weight of all occupants, cargo, and accessories, and the tongue load if you are towing a trailer.  
Steps for Determining Correct Load Limit -

- (1)** Locate the statement "The combined weight of occupants and cargo should never exceed XXX kg or XXX lbs." on your vehicle's placard.
- (2)** Determine the combined weight of the driver and passengers that will be riding in your vehicle.
- (3)** Subtract the combined weight of the driver and passengers from XXX kg or XXX lbs.
- (4)** The resulting figure equals the available amount of cargo and luggage load capacity. For example, if the "XXX" amount equals 1,400 lbs. and there will be five 150 lb. passengers in your vehicle, the amount of available cargo and luggage load capacity is 650 lbs.  
(1,400 - 750 (5 x 150) = 650 lbs.)

Continued

### Maximum Load Limit

## ⚠ WARNING

Overloading or improper loading can affect handling and stability and cause a crash in which you can be hurt or killed.

Follow all load limits and other loading guidelines in this manual.

Gross Vehicle Weight Rating (GVWR):  
The maximum allowable weight of the vehicle, all occupants, all accessories, all cargo, and the tongue load.

📖 **Specifications** P. 254







Gross Axle Weight Rating (GAWR):  
The maximum allowable weight of the vehicle axle.

📖 **Specifications** P. 254

- (5) Determine the combined weight of luggage and cargo being loaded on the vehicle. That weight may not safely exceed the available cargo and luggage load capacity calculated in step 4.
- (6) If your vehicle will be towing a trailer, load from your trailer will be transferred to your vehicle. Consult this manual to determine how this reduces the available cargo and luggage load capacity of your vehicle.

In addition, the total weight of the vehicle, all occupants, accessories, cargo, and trailer tongue load must not exceed the Gross Vehicle Weight Rating (GVWR) or the Gross Axle Weight Rating (GAWR). Both are on a label on the driver's doorjamb.

**Load Limits Example**

<p>Example1</p>  <p>Max Load 850 lbs (385 kg)</p>	$\geq$		$+$		<p>Passenger Weight 150 lbs x 2 = 300 lbs (68 kg x 2 = 136 kg)</p> <p>Cargo Weight 550 lbs (249 kg)</p>
<p>Example2</p>  <p>Max Load 850 lbs (385 kg)</p>	$\geq$		$+$		<p>Passenger Weight 150 lbs x 5 = 750 lbs (68 kg x 5 = 340 kg)</p> <p>Cargo Weight 100 lbs (45 kg)</p>

Your vehicle is not designed to tow a trailer. Attempting to do so can void your warranties.

### Towing Your Vehicle

---

Your vehicle is not designed to be towed behind a motor home. If your vehicle needs to be towed in an emergency, refer to the emergency towing information.

📄 **Emergency Towing** P. 250

## Turning on the Power

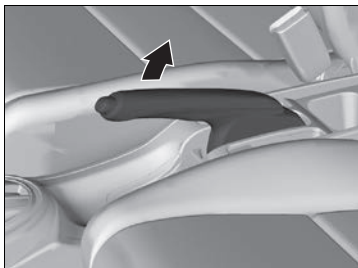

1. Make sure the parking brake is applied.

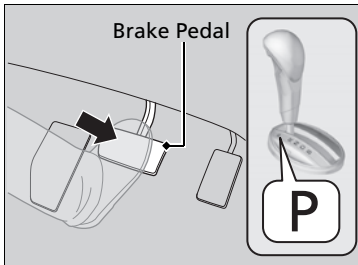

2. Check that the shift lever is in **P**, then depress the brake pedal.

▶ Although it is possible to start the vehicle in **N**, it is safer to start it in **P**.

### When Driving

When you turn the power switch to ON **II**, you may feel as if the brake pedal sinking down. This is normal.

### Turning on the Power

Keep your foot firmly on the brake pedal when activating the power system.

Turn on the power system in cold weather, turn off all electrical accessories such as the lights, climate control system, and rear defogger in order to reduce battery drain.

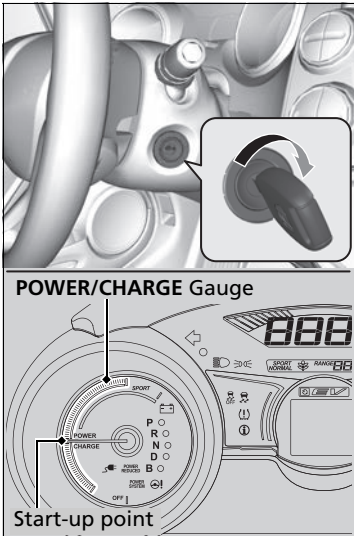



3. Turn the power switch to START  without depressing the accelerator pedal.
  - ▶ The **READY TO DRIVE** message appears on the multi-information display and a buzzer sounds.
  - ▶ The **POWER/CHARGE** gauge pointer goes to the start-up point.

#### Turning on the Power

The immobilizer system protects your vehicle from theft. If an improperly coded key (or other device) is used, the power system does not activate.

When you turn the power switch to ON , you may feel the brake pedal slightly sink down. This is normal.

### Starting to Drive

1. Keeping your right foot on the brake pedal, release the parking brake. Check that the brake warning indicator has gone off.
2. Put the shift lever in . Select  when reversing.
3. Gradually release the brake pedal and gently depress the accelerator pedal to pull away.



## Precautions While Driving

### In Rain

Avoid driving in deep water and on flooded roads. This can damage the power system, and driveline, or cause electrical component failure.

### Other Precautions

If there is a strong impact with something under the vehicle, stop in a safe location. Check the underside of the vehicle for damage or any fluid leaks.

## Transmission

### Creeping

As with a conventional gasoline powered vehicle with an automatic transmission, this vehicle will creep.

Keep the brake pedal firmly depressed when stopped.

### Precautions While Driving

#### NOTICE

Do not operate the shift lever while pressing the accelerator pedal.

If the power switch is turned to ACCESSORY [1] or LOCK [0] while driving, the power system goes down and all steering and brake power assist functions stop, making it difficult to control the vehicle.

Do not put the shift lever in [N], as you will lose regenerative braking (and acceleration) performance.

Avoid hard braking for the first 200 miles (300 km). You should also follow this when the brake pads are replaced.

#### NOTICE

The following can damage the under spoiler:

- Parking the vehicle by a parking block
- Parallel parking along the road shoulder
- Driving towards the bottom of a hill
- Driving up or down to a different surface level (such as a road shoulder)
- Driving on a rutted or bumpy road
- Driving on a road with potholes.

## Shifting

Change the shift position in accordance with your driving needs.

### ■ Shift lever positions

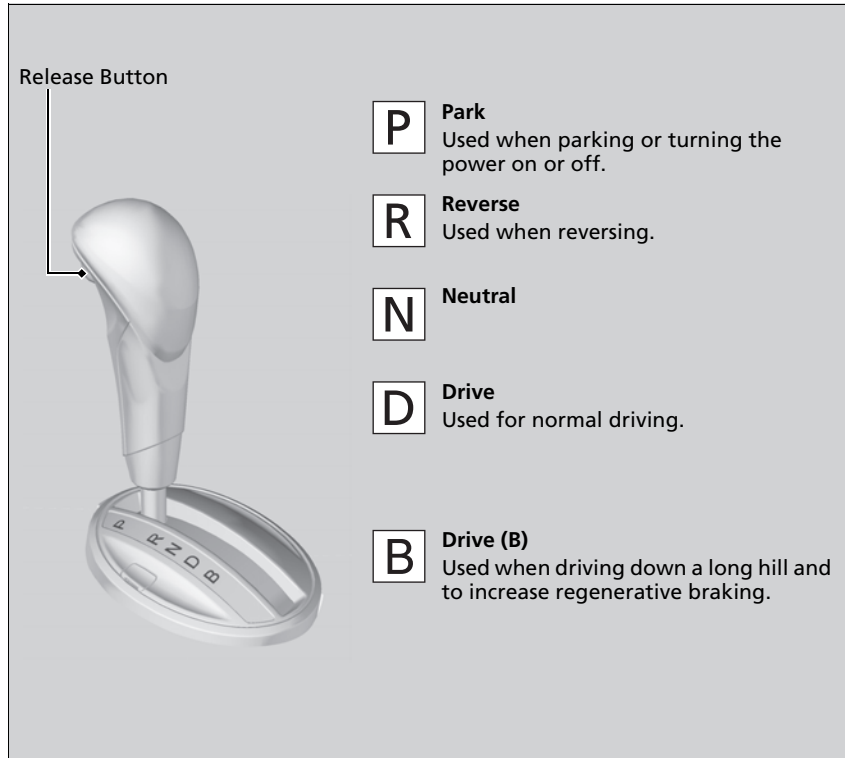

### ▶▶ Shifting

While the High Voltage battery level is full, or the High Voltage battery temperature is low, regenerative braking may become less effective.

You cannot turn the power switch to LOCK **[0]** and remove the key unless the shift lever is in **[P]**.

## ■ Shift Lever Operation

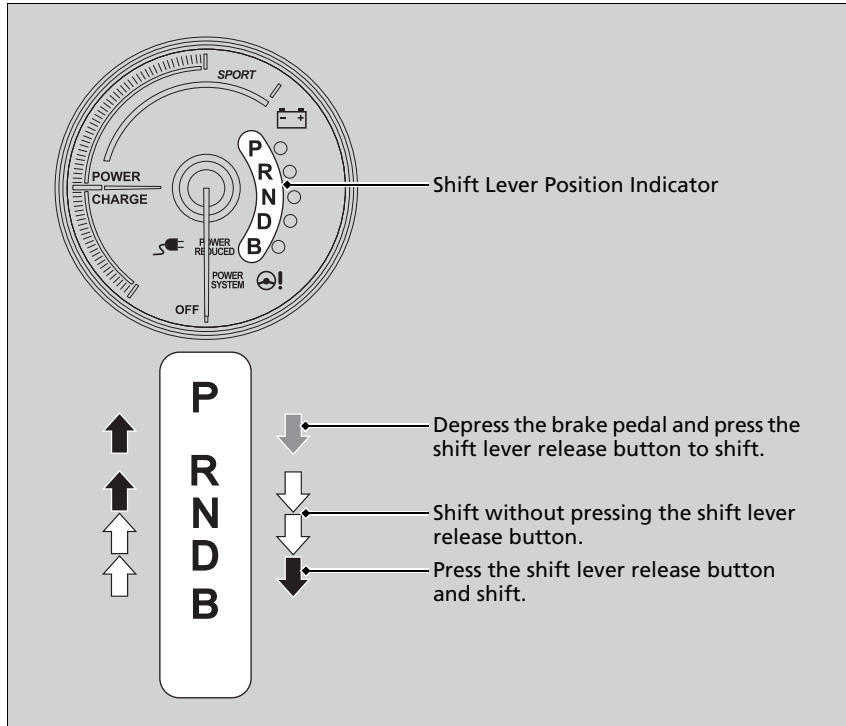

## ▶ Shift Lever Operation

When you change the shift lever from **D** to **R** and vice versa, come to a complete stop and keep the brake pedal depressed.

Use the shift lever position indicator to check the lever position before pulling away.

Whichever position the shift lever is in when driving, a blinking **D** indicator indicates a transmission problem.

Avoid sudden acceleration and have the transmission checked by an authorized Honda Fit EV dealer as soon as possible.

It may not be possible to operate the shift lever if the brake pedal is applied while the shift lever release button is held down.

Depress the brake pedal first.

## 3-Mode Drive System

There are three driving modes for your vehicle: SPORT, NORMAL, and ECON.

Each mode offers a different level of driving performance. The mode buttons are located on the control panel.

To change driving modes, press the desired mode button with the power switch ON **II**. The corresponding mode indicator comes on in the instrument panel, and the mode icon appears briefly on the multi-information display.

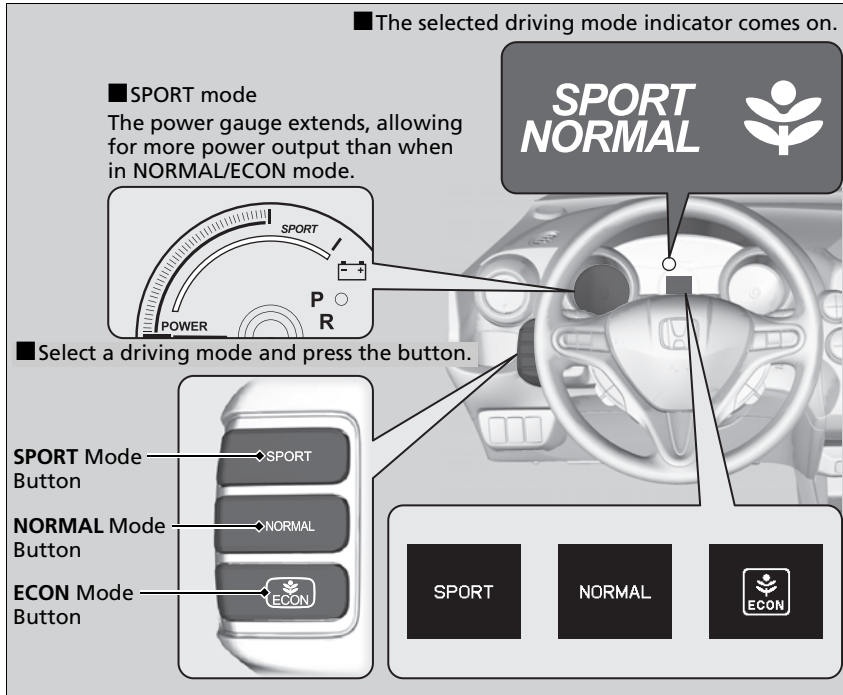

### 3-Mode Drive System

If you have selected the ECON mode, it remains on next time you turn the power switch to ON **II**. If the SPORT mode has been selected, the mode returns to NORMAL.

If you always want to start driving in NORMAL regardless of the mode you have selected last time you drove, go to **METER SETUP** and select **HOLD ECON MODE** on the multi-information display.

The ECON mode helps you improve your vehicle range by changing the motor, climate control system, cruise control, and high voltage system performances.

While in ECON mode, the climate control system has greater temperature fluctuations.

## Acoustic Vehicle Alerting System

Alerts pedestrians that a vehicle is approaching when the vehicle speed is around 12 mph or less.

## Cruise Control

Maintains a constant vehicle speed without having to keep your foot on the accelerator. Use cruise control on freeways or open roads where you can travel at a constant speed with little acceleration or deceleration.

### When to use

- **Vehicle speed for cruise control:**  
Desired speed in a range above roughly 25 mph (40 km/h) ~
- **Shift positions for cruise control:**  
In **D**

Always keep sufficient distance between you and the vehicle in front of you.



### How to use

- Press the **CRUISE** button on the steering wheel.

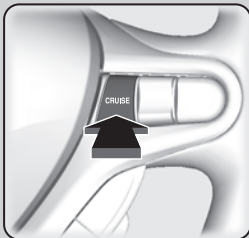

CRUISE  
MAIN

**CRUISE MAIN** is on in the instrument panel.  
Cruise control is ready to use.

### ⊗ Cruise Control

## ⚠ WARNING

Improper use of the cruise control can lead to a crash.

Use the cruise control only when traveling on open highways in good weather.

It may not be possible to maintain a constant speed when driving uphill or downhill.

When not using cruise control:  
Turn off cruise control by pressing the **CRUISE** button.

While in the ECON mode, it may take relatively more time to accelerate.

## ■ To Set the Vehicle Speed

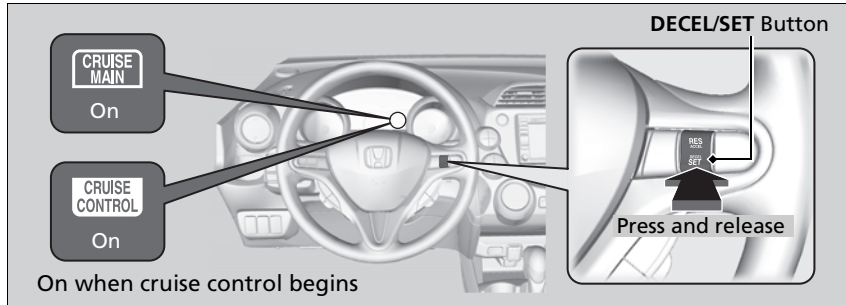

Take your foot off the pedal and press the **DECEL/SET** button when you reach the desired speed.

The moment you release the **DECEL/SET** button, the set speed is fixed, and cruise control begins. The **CRUISE CONTROL** indicator comes on.

## ■ To Adjust the Vehicle Speed

Increase or decrease the vehicle speed using the **RES/ACCEL** or **DECEL/SET** buttons on the steering wheel.

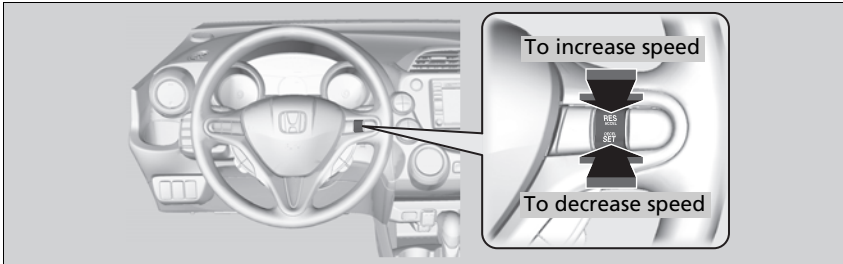

- Each time you press the button, the vehicle speed is increased or decreased by about 1 mph (1.6 km/h).
- If you keep the button pressed, the vehicle speed increases or decreases until you release it. This speed is then set.

## ■ To Cancel

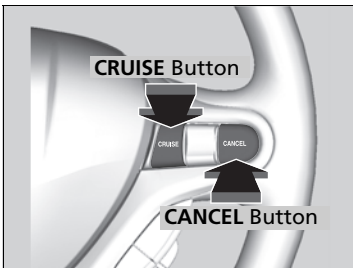

To cancel cruise control, do any of the following:

- Press the **CANCEL** button.
- Press the **CRUISE** button.
- Depress the brake pedal.

The **CRUISE CONTROL** indicator goes off.

### ☒ To Adjust the Vehicle Speed

You can set the vehicle speed using the **DECEL/SET** button on the steering wheel when adjusting the speed with the accelerator and brake pedals.

### ☒ To Cancel

Resuming the prior set speed:

After cruise control has been canceled, you can still resume the prior set speed by pressing the **RES/ACCEL** button while driving at a speed of at least 25 mph (40 km/h) or more.

You cannot set or resume in the following situations:

- When vehicle speed is less than 25 mph (40 km/h)
- When the **CRUISE** button is turned off

At vehicle speeds of 22 mph (35 km/h) or less, cruise control is canceled automatically.



## VSA® (Vehicle Stability Assist), aka ESC (Electronic Stability Control), System

VSA® helps to stabilize the vehicle during cornering if the vehicle turns more or less than what was intended. It also assists in maintaining traction on slippery surfaces. It does so by regulating motor output and selectively applying the brakes.

### ⚠ VSA® (Vehicle Stability Assist), aka ESC (Electronic Stability Control), System

VSA® may not function properly if tire types and sizes are mixed. Make sure to use the same size and type of tire, and the air pressures are as specified.

When the VSA® indicator comes on and stays on while driving, there may be a problem with the system. While this may not interfere with normal driving, have your vehicle checked by an authorized Honda Fit EV dealer immediately.

VSA® cannot enhance stability in all driving situations and does not control the entire braking system. You still need to drive and corner at speeds appropriate for the conditions and always leave a sufficient margin of safety.

The main function of the VSA® system is generally known as Electronic Stability Control (ESC). The system also includes a traction control function.

### ■ VSA® Operation

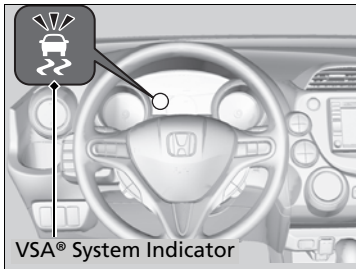

When VSA® activates, you may notice that the motor does not respond to the accelerator. You may also notice some noise from the hydraulic system. You will also see the indicator blink.

## VSA® On and Off

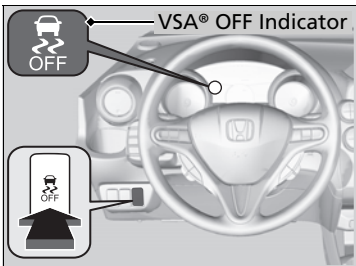

This button is on the driver side control panel. To turn the VSA® system on and off, press and hold it until you hear a beep.

VSA® will stop and the indicator will come on.

To turn it on again, press the  (VSA® OFF) button until you hear a beep.

VSA® is turned on every time you start the motor, even if you turned it off the last time you drove the vehicle.

## VSA® (Vehicle Stability Assist), aka ESC (Electronic Stability Control), System

Without VSA®, your vehicle will have normal braking and cornering ability, but it will not have VSA® traction and stability enhancement.

In certain unusual conditions when your vehicle gets stuck in shallow mud or fresh snow, it may be easier to free it with the VSA® temporarily switched off.

When the VSA® system is off, the traction control system is also off. You should only attempt to free your vehicle with VSA® off if you are not able to free it when the VSA® is on.

Immediately after freeing your vehicle, be sure to switch VSA® on again. We do not recommend driving your vehicle with the VSA® and traction control systems switched off.

If the low tire pressure or TPMS indicator comes on or blinks, the VSA® system comes on automatically. In this case, you cannot turn the system off by pressing the  button.

You may hear a motor sound coming from the motor compartment while system checks are being performed immediately after starting the motor or while driving. This is normal.

## TPMS (Tire Pressure Monitoring System)



Monitors the tire pressure while you are driving. If your vehicle's tire pressure becomes significantly low, the low tire pressure indicator comes on.

### ▶ TPMS (Tire Pressure Monitoring System)

Conditions such as low ambient temperature and altitude change directly affect tire pressure and can trigger the low tire pressure indicator to come on.

#### ▶ If the Low Tire Pressure/TPMS Indicator Comes On or Blinks P. 244

Tire pressure checked and inflated in:

- Warm weather can become under-inflated in colder weather.
- Cold weather can become over-inflated in warmer weather.

The low tire pressure indicator will not come on as a result of over inflation.

## Tire Pressure Monitoring System (TPMS) - Required Federal Explanation

---

Each tire, including the spare (if provided), should be checked monthly when cold and inflated to the inflation pressure recommended by the vehicle manufacturer on the vehicle placard or tire inflation pressure label.

(If your vehicle has tires of a different size than the size indicated on the vehicle placard or tire inflation pressure label, you should determine the proper tire inflation pressure for those tires.)

As an added safety feature, your vehicle has been equipped with a tire pressure monitoring system (TPMS) that illuminates a low tire pressure telltale



when one or more of your tires is significantly under-inflated.

Accordingly, when the low tire pressure telltale illuminates, you should stop and check your tires as soon as possible, and inflate them to the proper pressure.

Driving on a significantly under-inflated tire causes the tire to overheat and can lead to tire failure. Under-inflation also reduces fuel efficiency and tire tread life, and may affect the vehicle's handling and stopping ability.

Please note that the TPMS is not a substitute for proper tire maintenance, and it is the driver's responsibility to maintain correct tire pressure, even if under-inflation has not reached the level to trigger illumination of the TPMS low tire pressure telltale.

Your vehicle has also been equipped with a TPMS malfunction indicator to indicate when the system is not operating properly. The TPMS malfunction indicator is combined with the low tire pressure telltale. When the system detects a malfunction, the telltale will flash for approximately one minute and then remain continuously illuminated. This sequence will continue upon subsequent vehicle start-ups as long as the malfunction exists.

When the malfunction indicator is illuminated, the system may not be able to detect or signal low tire pressure as intended.

TPMS malfunctions may occur for a variety of reasons, including the installation of replacement or alternate tires or wheels on the vehicle that prevent the TPMS from functioning properly.

Always check the TPMS malfunction telltale after replacing one or more tires or wheels on your vehicle to ensure that the replacement or alternate tires and wheels allow the TPMS to continue to function properly.

## Brake System

### ■ Parking Brake

Use the parking brake to keep the vehicle stationary when parking.

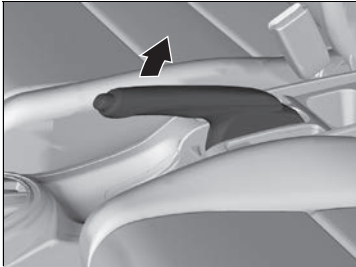

#### To apply:

Pull the lever fully up without pressing the release button.

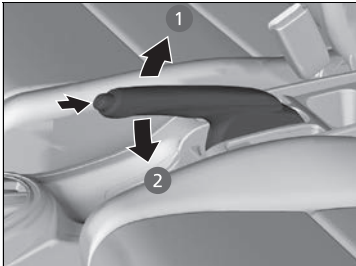

#### To release:

1. Pull the lever slightly, and press and hold the release button.
2. Lower the lever down all the way, then release the button.

#### ▣ Brake System

When you depress the brake pedal, you may hear a whirling sound from the motor compartment. This is because the brake system is in operation, and it is normal.

#### ▣ Parking Brake

##### NOTICE

Release the parking brake fully before driving. The rear brakes and axle can be damaged if you drive with the parking brake applied.

If you start driving without fully releasing the parking brake, a buzzer sounds as a warning, and **RELEASE PARKING BRAKE** appears on the multi-information display.

Always apply the parking brake when parking.

## ■ Foot Brake

Your vehicle is equipped with front disc brakes. The brakes on the rear wheels are drum. A power assist helps reduce the effort needed on the brake pedal. The brake assist system increases the stopping force when you depress the brake pedal hard in an emergency situation. The anti-lock brake system (ABS) helps you retain steering control when braking very hard.

➤ **Brake Assist System** P. 168

➤ **ABS (Anti-lock Brake System)** P. 167

## ☒ Foot Brake

Check the brakes after driving through deep water, or if there is a buildup of road surface water. If necessary, dry the brakes by lightly depressing the pedal several times.

If you hear a continuous metallic friction sound when applying the brakes, the brake pads need to be replaced. Have the vehicle checked by an authorized Honda Fit EV dealer.

Constantly using the brake pedal while going down a long hill builds up heat, which reduces the brake effectiveness. Apply regenerative braking by taking your foot off the accelerator pedal and shifting to position B.

Do not rest your foot on the brake pedal while driving, as it will lightly apply the brakes and cause them to lose effectiveness over time and reduce pad life. It will also confuse drivers behind you.

## ABS (Anti-lock Brake System)

### ■ ABS

Helps prevent the wheels from locking up, and helps you retain steering control by pumping the brakes rapidly, much faster than you.

The electronic brake distribution (EBD) system, which is part of the ABS, also balances the front-to-rear braking distribution according to vehicle loading.

You should never pump the brake pedal. Let the ABS work for you by always keeping firm, steady pressure on the brake pedal. This is sometimes referred to as “stomp and steer.”

### ■ ABS operation

The brake pedal may pulsate slightly when the ABS is working. Keep holding the pedal firmly down. On dry pavement, you will need to press on the brake pedal very hard before the ABS activates. However, you may feel the ABS activate immediately if you are trying to stop on snow or ice.

When the vehicle speed goes under 6 mph (10 km/h), the ABS stops.

### ▶▶ ABS (Anti-lock Brake System)

#### NOTICE

The ABS may not function correctly if you use an incorrect tire type and size.

When the **ABS** indicator comes on while driving, there may be a problem with the system. While normal braking is not affected, there is a possibility of the ABS not operating. Have the vehicle checked by an authorized Honda Fit EV dealer immediately.

The ABS does not reduce the time or distance it takes to stop the vehicle. It only helps with steering control during hard braking.

In the following cases, your vehicle may need more stopping distance than a vehicle without the ABS:

- When driving on rough road surfaces, including when driving on uneven surfaces, such as gravel or snow.
- When tire chains are installed.

You may hear a motor sound coming from the motor compartment while system checks are being performed immediately after turning the power switch to START **III** or while driving. This is normal.



## Brake Assist System

---

### ■ Brake Assist System

Designed to assist the driver by generating greater braking force when you depress the brake pedal hard during emergency braking.

#### ■ Brake assist system operation

Press the brake pedal firmly for more powerful braking.

When brake assist operates, the pedal may wiggle slightly and an operating noise may be heard. This is normal. Keep holding the brake pedal firmly down.

## When Stopped

1. Depress the brake pedal firmly with the shift lever in **D**.
  2. Apply the parking brake.
  3. Move the shift lever from **D** to **P**.
  4. Turn off the power system.
- Always set the parking brake firmly, in particular if you are parked on an incline.

### When Stopped

#### NOTICE

The following can damage the driveline:

- Depressing the accelerator and brake pedals simultaneously.
- Moving the shift lever into **P** before the vehicle stops completely.

When facing uphill, do not hold the vehicle by depressing the accelerator pedal.

Doing so may cause the power system to overheat and fail.

Raise the wiper arms when snow is expected.

### About Your Rearview Camera

---

See the Navigation System Manual for operation of the rearview camera.

## Before Charging

Check the following items before you start charging your vehicle.

### Safety Checklist

- The 120 volt charger draws approximately 12 amps. Make sure to use a dedicated and properly grounded circuit that can supply 12 amps continuously.
  - ▶ Have an electrician inspect the outlet you are using to see if it meets these criteria.
- Make sure you plug the charging cable directly into the wall outlet dedicated to vehicle charging.
  - ▶ Do not use extension cords, adaptors, or multi-outlet plugs between the charging cable and the outlet.
- Make sure the charging cable is fully uncoiled before use.
- Make sure the control box, charge connector, and charging cable are free from any damage, including cracks or frays.
  - ▶ If you find any damage to the devices, contact an authorized Honda Fit EV dealer.
- Make sure the charge connector and inlet are clean.
  - ▶ If you find any contamination or foreign object in the connector or inlet, contact an authorized Honda Fit EV dealer.
- Make sure the charging cable is dry.
  - ▶ Check that there is no water in the immediate area, and that your hands are dry.

### Charging

#### **⚠ WARNING**

Using a 120 volt wall outlet that is rated less than 12 amps or one that is powering other devices can cause a fire, seriously injuring you or others.

When using the 120 volt charger, make sure to use a dedicated and properly grounded circuit that can supply 12 amps continuously. Consult an electrician if you are not sure.

## Charge the High Voltage battery using a Level 1 or 2 charger

There are two ways to charge the High Voltage battery; by using the Level 1 120 volt (12 amp) charger supplied with the vehicle plugged into a standard three-prong wall outlet, or by using a professionally installed Level 2 240 volt (32 amp) charger.

Charging with	Suggested full charging time
AC 240 V (Level 2)	3 hours* <sup>1</sup>
AC 120 V (Level 1)	15 hours* <sup>1</sup>

\*<sup>1</sup>: Charging time varies depending on conditions, such as the remaining battery level and the ambient temperature.

The suggested full charging time in this table indicates the hours it may likely take for the High Voltage battery to be fully charged from the moment the low charge indicator comes on with the ambient temperature at 77°F.

### ⚠ Charging

## ⚠ WARNING

Improper usage and handling of the 120 volt charger can cause a fire, seriously injuring you or others.

- Always insert the plug fully into a properly rated and grounded the wall outlet.
- Plug the charging cable directly to the wall outlet. Do not use extension cords or multi-plug adapters.
- Prevent the vehicle charge connector from becoming contaminated. Clean if necessary.

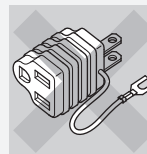
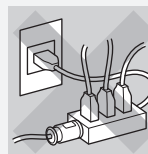
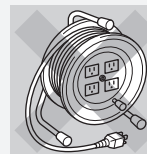

## How to Charge (Level 1)

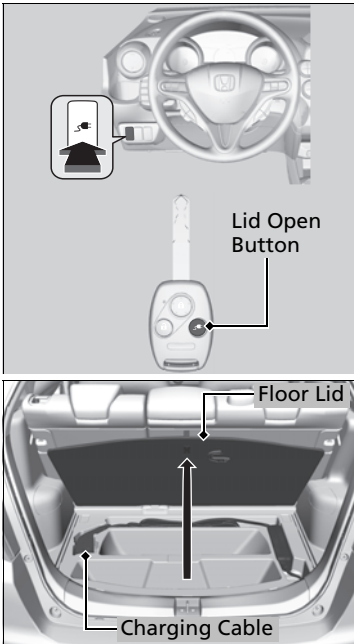

1. Turn the power switch to LOCK [0], and move the shift lever to [P].
2. Press and hold the lid open button on the remote transmitter, or press and hold the charge lid release button on the dashboard.  
▶ The lid opens.
3. Open the cargo area floor lid and take out the charge connector.  
▶ Do not tie or coil the cable when in use.

## ⚠ Charging

### ⚠ WARNING

Charging the High Voltage battery under the following conditions is a potential source of electric shock and fire, which can result in serious injury or death:

- Charging the battery during an electric storm.
- Using the charging cable near water or handling with wet hands.
- Using a charger, whose case is broken or cracked or whose cable is frayed or damaged.

Never charge the vehicle in any of the above situations.

### ⚠ WARNING

Using a charger that is damaged or modified can cause electrical shock and fire, which can result in serious injury or death.

Never disassemble or modify the charger. If the charger becomes damaged, stop using it and consult your dealer.

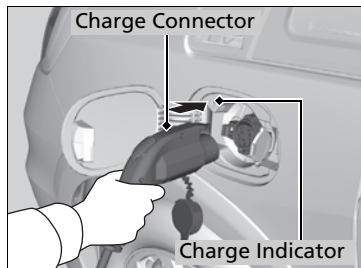
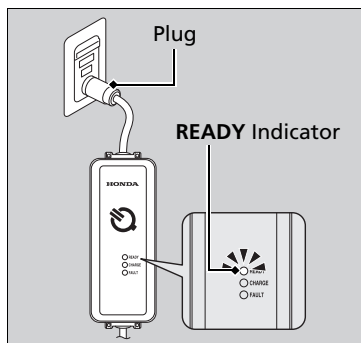
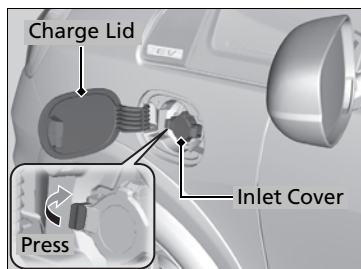

4. Open the vehicle's charge lid and inlet cover.

- ▶ The illumination lamp inside the charge lid comes on for a few minutes.

5. Insert the plug into a 120 volt wall outlet.

- ▶ Insert the plug completely until it stops.

6. Check that the **READY** indicator on the control box comes on.

7. Remove the cover from the charge connector. Align and insert the charge connector into the vehicle's inlet until you hear a click.

- ▶ The charge indicator stops blinking, and stays on when charging starts.

#### ⊠ Charging

##### NOTICE

Do not charge the vehicle with a vehicle cover on. It can cause a malfunction and damage the vehicle or charging components

Keep the hood closed while the vehicle is being charged. If the hood is open, charge time may become longer since the cooling fan does not turn.

The 120 volt charger requires a properly grounded and dedicated circuit that is protected by a 15 amp or greater over-current protection device (circuit breaker). For more information consult an authorized Honda dealer.

We recommend that a GFCI (ground-fault circuit interrupter) protected outlet be used to charge the vehicle. Follow the GFCI maker's installation instructions, or consult an electrician if you are not sure about installation requirements.

Inspect the charging cable plug and charging connector, as well as the vehicle's charge inlet, before use. If the plug or connector are dirty or otherwise contaminated, carefully clean them with a dry clean cloth before use. Do not wipe the metal part of the inlet and the charge connector by yourself. Also, if you are unable to clean the plug or connector, if the inlet is dirty, or if any are damaged or corroded, take the charging cable and vehicle to an authorized dealer for inspection and possible repair.

Before using a vehicle charging cable, inspect the cable for damage such as scratches, cracks, or tears. If you find any damage, do not use the charging cable; instead, take it to an authorized Honda dealer for inspection.

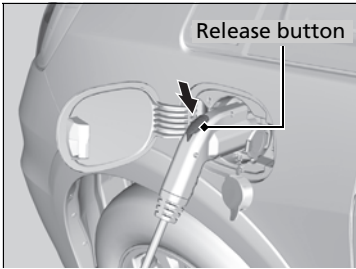

### ■ When charging is completed

Press the release button on the charge connector to release it from the inlet.

- ▶ Make sure to close the inlet cover before you close the charge lid.

The charge indicator goes off once charging is completed.

## ■ How to Charge (Level 2)

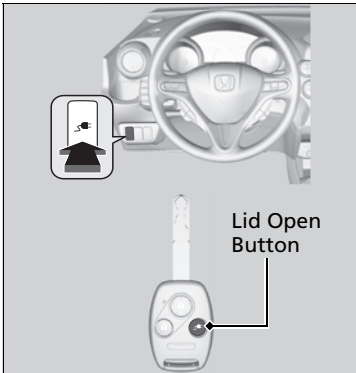

1. Stop your vehicle at a station specific for electric vehicles. Park with the charge lid closest to the charge plug, just in front of the driver's door.
2. Move the shift lever to **P**.
3. Turn off the power system.
4. Press and hold the charge lid release button.
  - ▶ The lid opens.

### ⊠ Charge the High Voltage battery using a Level 1 or 2 charger

If a blackout or other electrical interruption occurs during vehicle charging, the vehicle will automatically resume charging once power is restored.

If you cannot start charging even if the charge connector is plugged into the inlet, check the following:

- If the charging timer has been set.
- If you have remotely canceled charging, using the interactive remote control.

To avoid damage to the charger, take these precautions:

- Do not hit the charge connector components with a hard object or drop them on the ground.
- Do not pull, twist, tangle, drag or step on the charging cable.
- Do not use or store near any sources of heat.
- Do not expose to liquids or use harsh chemicals to clean.

If you unplug the charge connector from the inlet, charging cancels automatically.

When you plug in or unplug the charge connector into or from the inlet, the navigation system comes on, performs a system checkup, and goes into standby mode. It automatically shuts off after a while. If you want to operate the system while it is in standby mode, turn the power switch to ACCESSORY **I** or ON **II**.



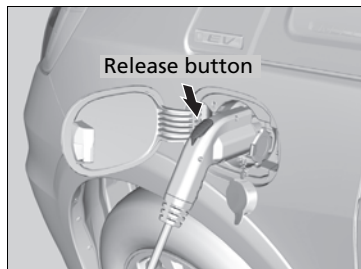
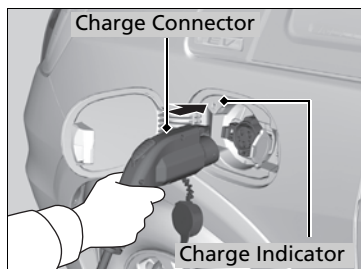
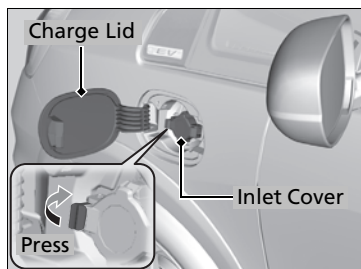

5. Open the charge lid and the inlet cover.

6. To connect the cable to the vehicle, push the cable's charge connector until it clicks to the charge lid.

- ▶ The charge indicator on the charge lid stays on.

■ **When charging is completed**

Press the release button on the charge connector to release it from the inlet.

- ▶ Make sure to close the inlet cover before you close the lid.

The charge indicator goes off once charging is completed.

⌘ **How to Charge (Level 2)**

The charge speed slows down towards the completion of the battery charging.

The charge lid can open by remote transmitter.

Under the following circumstances, the High Voltage battery may not be charged even if the charge connector is properly connected to the vehicle's inlet:

- When the charging timer is set but the timer has not yet started.
- When the High Voltage battery's charge mode has been remotely turned off.

Be sure to follow the instructions and safety precautions provided with the Level 2 charging equipment.

## Control Box

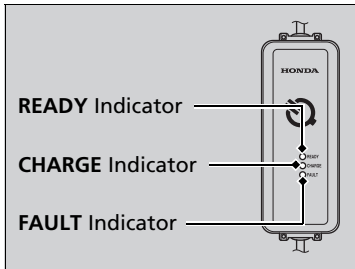

**READY:** Comes on when the charging cable is plugged into the wall outlet.

Blinks when the ground wire is disconnected. Inspect if the circuit is grounded.

**CHARGE:** Comes on during charge, or when the climate control system is in use while the charging cable is plugged in.

**FAULT:** Comes on if there is a problem with the charging cable. Stop using the cable immediately, and contact an authorized Honda Fit EV dealer.

## ■ What to do when you cannot start charging

If charging does not start, even if the **READY** indicator comes on, and the charge connector is plugged in, perform one of the following solutions.

Cause	Solution
The timer has been set, but the start time is in the future.	Start charging using the interactive remote. <ul style="list-style-type: none"> <li>▶ The timer will also start charging if the cable is plugged in, and the battery needs to be recharged at a set time.</li> </ul>
	Change the customized setting of the charge timer to OFF using the multi-information display. <ul style="list-style-type: none"> <li>▶ The timer setting will be canceled.</li> <li>📖 <b>Using a Timer</b> P. 182</li> </ul>
Charging was canceled using the remote before the charge connector was unplugged.	Restart charging using the remote.
	Turn the power switch ON <b>II</b> briefly, then LOCK <b>0</b> .
The shift lever is in a position other than <b>P</b> .	Move the shift lever to <b>P</b> .
The 12 volt battery is weaken.	Check the 12 volt battery condition. If necessary, charge the battery.
The power switch is in ON <b>II</b> .	Turn the power switch to ACCESSORY <b>I</b> or LOCK <b>0</b> .
The charge connector is not properly attached to the vehicle's inlet.	Release the connector from the inlet.
	Align and insert the connector into the inlet until you hear a click.

Note: The charging equipment provided with this vehicle has been tested and found to comply with the limits for a Class B digital device, pursuant to part 15 of the FCC Rules.

These limits are designed to provide reasonable protection against harmful interference in a residential installation.

This equipment generates, uses and can radiate radio frequency energy and, if not installed and used in accordance with the instructions, may cause harmful interference to radio communications.

However, there is no guarantee that interference will not occur in a particular installation.

If this equipment does cause harmful interference to radio or television reception, which can be determined by turning the equipment off and on, the user is encouraged to try to correct the interference by one or more of the following measures:

- Reorient or relocate the receiving antenna.
- Increase the separation between the equipment and receiver.
- Connect the equipment into an outlet on a circuit different from that to which the receiver is connected.
- Consult the dealer or an experienced radio/TV technician for help.

## ■ Charge Indicator on the Vehicle Side

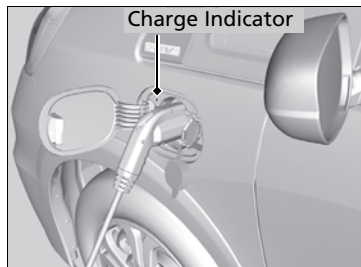

Shows the High Voltage battery charging status.

If it blinks for a while, then stays on after the charge connector is plugged in, it indicates that the battery is being charged.

Indicator status	Explanation
Blinks slowly	<ul style="list-style-type: none"> <li>• The charger is ready to charge the battery.</li> <li>• Charging is programmed to start using the timer.                             <ul style="list-style-type: none"> <li>▶ The indicator goes off after about 15 seconds.</li> </ul> </li> <li>• The power switch is turned to ON <span style="border: 1px solid black; padding: 0 2px;">II</span> while the battery is being charged.</li> </ul>
Stays on	<ul style="list-style-type: none"> <li>• The battery is being charged.</li> <li>• The climate control system is activated with the remote while the charging cable is plugged in.</li> </ul>
Goes off	<ul style="list-style-type: none"> <li>• Charging is complete.</li> </ul>
Blinks rapidly	<ul style="list-style-type: none"> <li>• There is a problem with the charging system.                             <ul style="list-style-type: none"> <li>▶ The indicator goes off after 15 seconds. Charging does not start.</li> </ul> </li> <li>• The charge inlet temperature increased and the charge rate was reduced to prevent overheating.                             <ul style="list-style-type: none"> <li>▶ It may take longer than usual to complete charging. See an authorized Honda Fit EV dealer if this problem persists.</li> </ul> </li> </ul>

## High Voltage Battery

The High Voltage battery gradually discharges even if the vehicle is not in use. As a result, if your vehicle is parked for an extended period of time, the battery level may get low. Keeping your vehicle's battery level low can shorten the battery life, negatively affecting the vehicle's range. To maintain the battery while the vehicle is not in use, recharge the battery at least once every three months.

The High Voltage battery life can also be affected by ambient temperature. In particular, when it is cold outside, the vehicle's driving range can be reduced, and a longer battery charging time is required. In addition, parking in extremely hot or cold environments can accelerate battery drain.

### ⌘ High Voltage Battery

The High Voltage battery drains over time, and under some conditions, drains faster. When the battery life is shortened, this changes the vehicle's driving distance.

## Using a Timer

You can set the timer for the High Voltage battery charge using the multi-information display's customization feature.

The vehicle automatically begins charging at the scheduled time when the charge connector is connected to the vehicle.

### Multi-Information Display

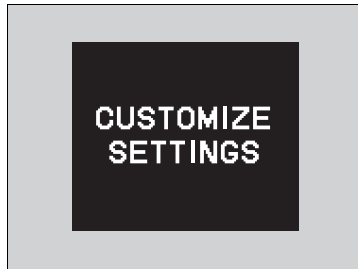

1. Press the /▼ button until **CUSTOMIZE SETTINGS** appears on the display, then press the **SEL/RESET** button.



2. Press the **SEL/RESET** button.

### Multi-Information Display

**TIMER:** Select **ON** or **OFF**

**MODE:** When **TIMER** is **ON**, select the charging mode, **FULL** or **TIME**.

**FULL:** Charging will continue until the battery is fully charged.

**TIME:** The battery will be charged between the time you have designated to start and end.

**START:** Set the time when to start the High Voltage battery charge.

**END:** Set the time when to end the High Voltage battery charging. You cannot set this when the **FULL** mode is selected.



3. Press the **SEL/RESET** button to select the item you want to set.
4. Press the **▲①/▼** button to select when to start and end the charging, and the charging mode.
5. Press the **SEL/RESET** button again.



## Improving Energy Economy

Fuel economy depends on several conditions, including driving conditions, your driving habits, the condition of your vehicle, and loading. Depending on these and other conditions, you may or may not achieve the rated fuel economy of this vehicle.

### Maintenance and Energy Economy

You can optimize your fuel economy with proper maintenance of your vehicle. Always maintain your vehicle in accordance with the messages displayed on the information display.

- Maintain the specified tire pressure.
- Do not load the vehicle with excess cargo.
- Keep your vehicle clean. A buildup of snow or mud on your vehicle's underside adds weight and increases wind resistance.

### Improving Energy Economy

Direct calculation is the recommended method to determine actual energy consumed while driving.

$$\boxed{\text{Miles driven}} \div \boxed{\text{Kilowatt hour of fuel}} = \boxed{\text{Miles per kWh}}$$

## Modifications

---

Do not modify your vehicle or use non-Honda components that can affect its handling, stability, and reliability.

Overall vehicle performance can be affected. Always make sure all equipment is properly installed and maintained, and that it meets federal, state, province, territory, and local regulations.



# Maintenance

This chapter discusses basic maintenance.



## **Before Performing Maintenance**

Inspection and Maintenance .....	188
Safety When Performing Maintenance...	189
Parts and Fluids Used in Maintenance	
Service .....	190

## **Maintenance Minder™**

When Required Maintenance Approaches..	191
--	-----

## **Maintenance Schedule** .....

Maintenance Record .....	194
--------------------------	-----

## **Maintenance Under the Hood**

Maintenance Items Under the Hood..	195
Opening the Hood .....	196

Cooling System.....	197
Climate Control Coolant.....	199
Brake Fluid.....	200
Refilling Window Washer Fluid.....	201

## **Replacing Light Bulbs** .....

## **Checking and Maintaining Wiper Blades**..

## **Checking and Maintaining Tires**

Checking Tires .....	211
Tire and Loading Information Label ...	212
Tire Labeling .....	212
DOT Tire Quality Grading (U.S. Vehicles)..	214
Wear Indicators.....	216

Tire Service Life.....	216
Tire and Wheel Replacement .....	217
Tire Rotation.....	218
Winter Tires .....	219

## **12 Volt Battery**.....

## **Remote Transmitter Care**.....

## **Interactive Remote Care** .....

## **Climate Control System Maintenance**...

## **Cleaning**

Interior Care .....	224
Exterior Care.....	225

## Inspection and Maintenance

For your safety, perform all listed inspections and maintenance to keep your vehicle in good condition. If you become aware of any abnormality (noise, smell, insufficient brake fluid, etc.), have your vehicle inspected by an authorized Honda Fit EV dealer. (Note, however, that service at an authorized Honda Fit EV dealer is not mandatory to keep your warranties in effect.) Refer to the separate maintenance booklet for detailed maintenance and inspection information.

### ▣ Inspection and Maintenance

At this time all maintenance will only be performed an authorized Honda Fit EV dealer.

### ■ Types of Inspection and Maintenance

#### ■ Daily inspections

Perform inspections before long distance trips, when washing the vehicle, or when charging.

#### ■ Periodic inspections

- Check the brake fluid level monthly.
  - ▣ **Brake Fluid** P. 200
- Check the tire pressure monthly. Examine the tread for wear and foreign objects.
  - ▣ **Checking and Maintaining Tires** P. 211
- Check the operation of the exterior lights monthly.
  - ▣ **Replacing Light Bulbs** P. 202
- Check the condition of the wiper blades at least every six months.
  - ▣ **Checking and Maintaining Wiper Blades** P. 207

## Safety When Performing Maintenance

Some of the most important safety precautions are given here. However, we cannot warn you of every conceivable hazard that can arise in performing maintenance. Only you can decide whether or not you should perform a given task.

### Maintenance Safety

- To reduce the possibility of fire or explosion, keep cigarettes, sparks, and flames away from the battery and all High Voltage system related parts.
- Never leave rags, towels, or other flammable objects under the hood.
  - ▶ Heat from the motor can ignite them causing a fire.
- Wear eye protection and protective clothing when working with the 12 volt battery or compressed air.

### Vehicle Safety

- The vehicle must be in a stationary condition.
  - ▶ Make sure your vehicle is parked on level ground, the parking brake is set, and the power system is turned off.
- Be aware that hot parts can burn you.
  - ▶ Make sure to let the power system cool thoroughly before touching vehicle parts.
- Be aware that moving parts can injure you.
  - ▶ Do not activate the power system unless instructed to do so. Keep your hands and limbs away from moving parts

#### ⚠ Safety When Performing Maintenance

### ⚠ WARNING

Improperly maintaining this vehicle or failing to correct a problem before driving can cause a crash in which you can be seriously hurt or killed.

Always follow the inspection and maintenance recommendations according to the schedules in this owner's manual.

### ⚠ WARNING

Failure to properly follow maintenance instructions and precautions can cause you to be seriously hurt or killed.

Always follow the procedures and precautions in this owner's manual.

## Parts and Fluids Used in Maintenance Service

---

The use of Honda genuine parts and fluids is recommended when maintaining and servicing your vehicle. Honda genuine parts are manufactured according to the same high quality standards used in Honda vehicles.







When your vehicle's travel distance has been accumulated, you will see a message that reminds you it is time to take your vehicle in for scheduled maintenance.

➤ **Maintenance Schedule** P. 193

## When Required Maintenance Approaches

A message appears on the multi-information display every time you turn the power switch to ON .

### Reminder Message on the Multi-Information Display

Reminder Message	Explanation	Information
	Your vehicle's accumulated distance is between 6,300 miles (10,140 km) and 7,500 miles (12,000 km). Once you switch the display by pressing the  /  button, this message will go off.	Your vehicle should be inspected and serviced soon.
	Your vehicle's accumulated distance has exceed 7,500 miles (12,000 km). Without performing scheduled maintenance. Press the  /  button to switch to another display.	Have the scheduled maintenance performed as soon as possible.



## ■ Resetting the Display

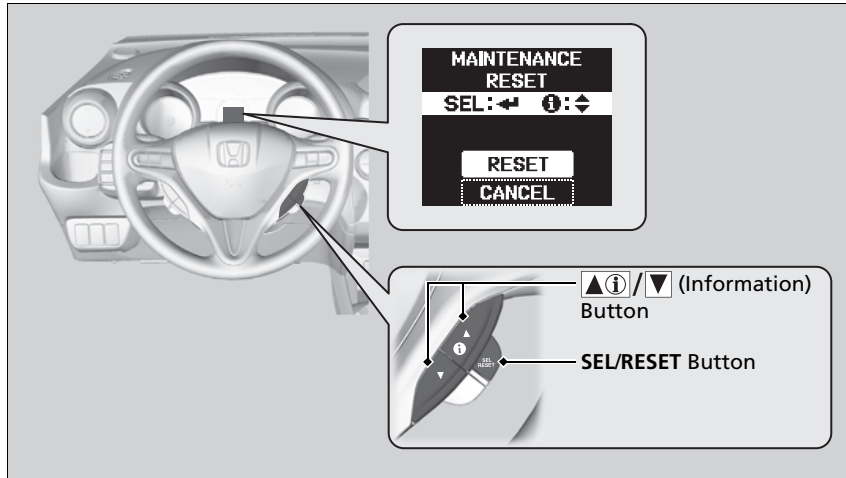

1. Press and hold the **SEL/RESET** button, and turn the power switch ON **II**.
  - ▶ Make sure that the light control switch is in **OFF**.
2. Continue holding the **SEL/RESET** button for 10 seconds or more.
  - ▶ The service reminder information reset mode is displayed on the multi-information display.
3. Select **RESET** using the **▲▲i/▼▼** button, then press the **SEL/RESET** button.
  - ▶ The service information will disappear.

To cancel the service reminder information reset mode, select **CANCEL**, then press the **SEL/RESET** button.

## ▣ Resetting the Display

The an authorized Honda Fit EV dealer will reset the maintenance reminder display after completing the required maintenance service.

If someone other than an authorized Honda Fit EV dealer performs maintenance service, reset it yourself.

# Maintenance Schedule

The maintenance schedule outlines the minimum required maintenance that you should perform to ensure the troublefree operation of your vehicle. Due to regional and climatic differences, some additional servicing may be required. Please consult your warranty booklet for a more detailed description.

Maintenance work should be performed by properly trained and equipped technicians. An authorized Honda Fit EV dealer meets all of these requirements.

Service at the indicated distance or time - whichever comes first.	miles x 1,000	15	30	45	60	75	90
	months	12	24	36	48	60	72
Inspect front and rear brakes	Normal	•	•	•	•	•	•
	Severe	Every 7,500 miles or 6 months					
Replace brake fluid		Every 3 years					
Check parking brake adjustment		•	•	•	•	•	•
Replace dust and pollen filter* <sup>1</sup>	Normal		•		•		•
	Severe	•	•	•	•	•	•
Check expiration date for TRK bottle		•	•	•	•	•	•
Rotate tires (Check tires inflation and condition at least once per month)		Every 7,500 miles					
<b>Visually inspect the following items:</b>							
Tie rod ends, steering gear box and boots Suspension components Driveshaft boots	Normal	•	•	•	•	•	•
	Severe	Every 7,500 miles or 6 months					
Brake hoses and lines (including ABS)		•	•	•	•	•	•
All fluid levels and condition of fluid		•	•	•	•	•	•

\*1: When you drive primarily in urban areas that have high concentrations of shot in air, under dusty conditions or the air flow from the heating and cooling/climate control system becomes less than usual. Replace the filter every 15,000 miles or 1 year.

Severe Conditions:

- Driving in hot (over 90°F) conditions.
- Driving on muddy, dusty, or de-iced roads.
- Driving in mountainous conditions.

## Maintenance Record

Have an authorized Honda Fit EV dealer record all required maintenance below. Keep receipts for all work done on your vehicle.

Mi. or Month	Date	Sign or Stamp
<b>15,000 Mi. (or 12 Mo.)</b>		
<b>30,000 Mi. (or 24 Mo.)</b>		
<b>45,000 Mi. (or 36 Mo.)</b>		
<b>60,000 Mi. (or 48 Mo.)</b>		
<b>75,000 Mi. (or 60 Mo.)</b>		
<b>90,000 Mi. (or 72 Mo.)</b>		

## Maintenance Items Under the Hood

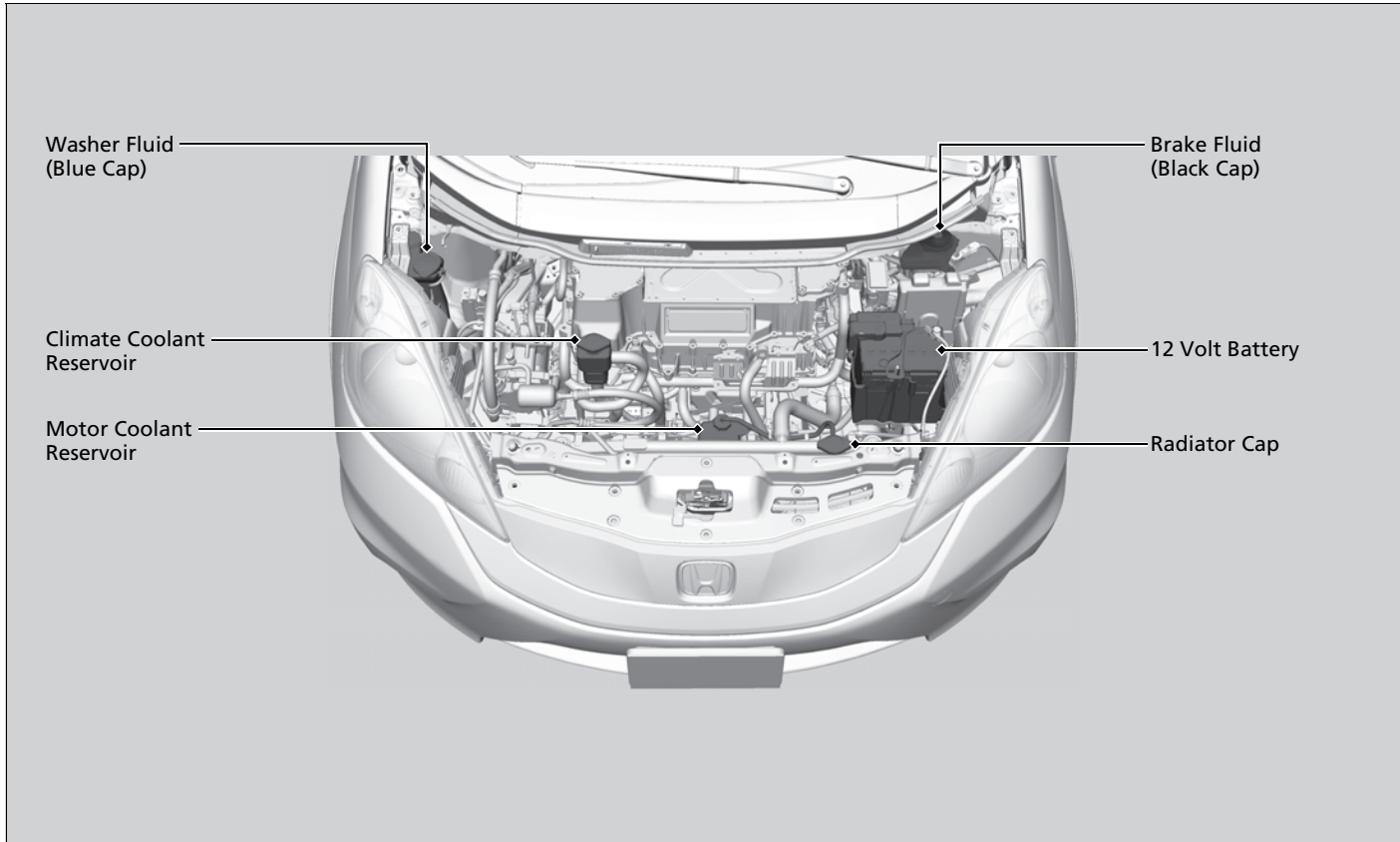

## Opening the Hood

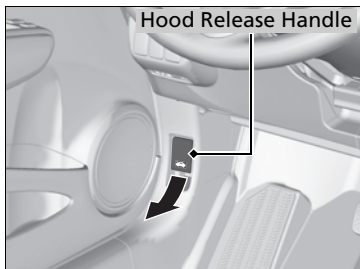

1. Park the vehicle on a level surface, and set the parking brake.
2. Pull the hood release handle under the lower left corner of the dashboard.
  - The hood will pop up slightly.

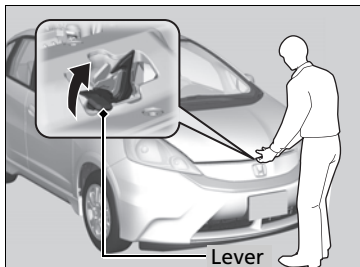

3. Push up the hood latch lever in the center of the hood to release the lock mechanism, and open the hood.

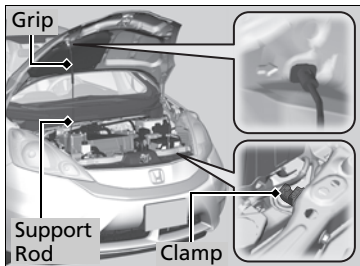

4. Remove the support rod from the clamp using the grip. Mount the support rod in the hood.

When closing, remove the support rod, and stow it in the clamp, then gently lower the hood. Remove your hand at a height of approximately 12 inches (30 cm) and let the hood close.

### ►► Opening the Hood

#### NOTICE

Do not open the hood when the wiper arms are raised. The hood will strike the wipers, and may damage either the hood or the wipers.

When closing the hood, check that the hood is securely latched.

If the hood latch lever moves stiffly, or if you can open the hood without lifting the lever, the latch mechanism should be cleaned and lubricated.

When the hood is open, the radiator fans and the climate control system will not operate.

## Cooling System

### Specified coolant: Honda Long Life Antifreeze/Coolant Type 2

This coolant is premixed with 50% antifreeze and 50% water. Do not add any straight antifreeze or water.

We recommend you check the coolant level every time you charge the High Voltage battery. Check the reserve tank first. If it is completely empty, also check the coolant level in the radiator. Add the coolant accordingly.

### Reserve Tank

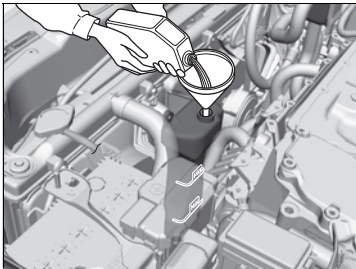
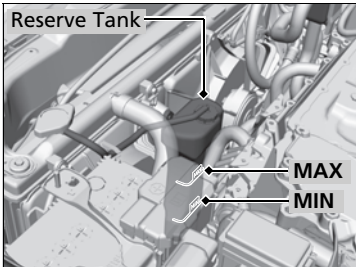

1. Check the amount of coolant in the reserve tank.

2. If the coolant level is below the **MIN** mark, add the specified coolant until it reaches the **MAX** mark.
3. Inspect the cooling system for leaks.

### ⌘ Cooling System

#### NOTICE

If Honda antifreeze/coolant is not available, you may use another major brand non-silicate coolant as a temporary replacement. Check that it is a high quality coolant recommended for aluminum motors. Continued use of any non-Honda coolant can result in corrosion, causing the cooling system to malfunction or fail. Have the cooling system flushed and refilled with Honda antifreeze/coolant as soon as possible.

Do not add rust inhibitors or other additives to your vehicle's coolant system. They may not be compatible with the coolant or with the motor components.

Continued

## Radiator

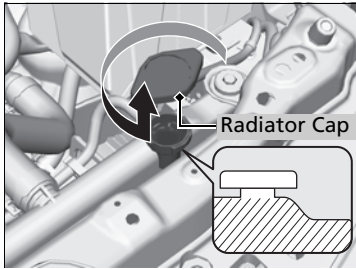

1. Make sure the motor and radiator are cool.
2. Turn the radiator cap counterclockwise and relieve any pressure in the coolant system. Do not push the cap down when turning.
3. Push down and turn the radiator cap counterclockwise to remove it.
4. The coolant level should be up to the base of the filler neck. Add coolant if it is low.
5. Put the radiator cap back on, and tighten it fully.
6. Pour coolant into the reserve tank until it reaches the **MAX** mark. Put the cap back on the reserve tank.

## Radiator

### **WARNING**

Removing the radiator cap while the motor is hot can cause the coolant to spray out, seriously scalding you.

Always let the motor and radiator cool down before removing the radiator cap.

### **NOTICE**

Pour the fluid slowly and carefully so you do not spill any. Clean up any spills immediately; they can damage components in the motor compartment.

## Climate Control Coolant

### Specified coolant: Honda Long Life Antifreeze/Coolant Type 2

This coolant is premixed with 50% antifreeze and 50% water. Do not add any straight antifreeze or water.

We recommend you check the coolant level every time you charge the High Voltage battery. Check the reserve tank. Add the climate control coolant accordingly.

### Reserve Tank

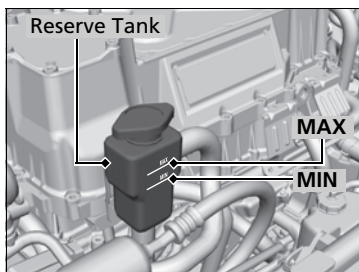

1. Check the amount of coolant in the reserve tank.

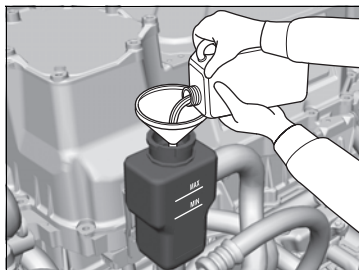

2. If the coolant level is below the **MIN** mark, add the specified coolant until it reaches the **MAX** mark.
3. Inspect the cooling system for leaks.

### Climate Control Coolant

#### NOTICE

If Honda antifreeze/coolant is not available, you may use another major brand non-silicate coolant as a temporary replacement. Check that it is a high quality coolant recommended for aluminum motors. Continued use of any non-Honda coolant can result in corrosion, causing the cooling system to malfunction or fail. Have the cooling system flushed and refilled with Honda antifreeze/coolant as soon as possible.

Do not add rust inhibitors or other additives to your vehicle's coolant system. They may not be compatible with the coolant or with the motor components.



## Brake Fluid

**Specified fluid: Honda Heavy Duty Brake Fluid DOT 3**

### ■ Checking the Brake Fluid

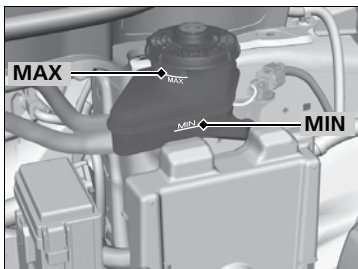

The fluid level should be between the **MIN** and **MAX** marks on the side of the reservoir.

### » Brake Fluid

#### NOTICE

Brake fluid marked DOT 5 is not compatible with your vehicle's braking system and can cause extensive damage.

If the specified brake fluid is not available, you should use only DOT 3 or DOT 4 fluid from a sealed container as a temporary replacement.

Using any non-Honda brake fluid can cause corrosion and decrease the longevity of the system. Have the brake system flushed and refilled with Honda Heavy Duty Brake Fluid DOT 3 as soon as possible.

If the brake fluid level is at or below the **MIN** mark, have an authorized Honda Fit EV dealer inspect for leaks or worn brake pads as soon as possible.

## Refilling Window Washer Fluid

Check the amount of washer fluid using the washer fluid level gauge on the cap. If the level is low, fill the washer reservoir.

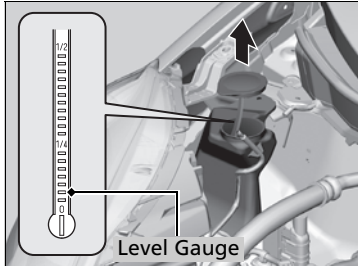

### ✘ Refilling Window Washer Fluid

#### NOTICE

Do not use motor antifreeze or a vinegar/water solution in the windshield washer reservoir. Antifreeze can damage your vehicle's paint. A vinegar/water solution can damage the windshield washer pump.

## Headlight Bulbs

When replacing, use the following bulbs.

**High/Low beam headlight: 60/55 W (HB2)**

### High/Low Beam Headlight

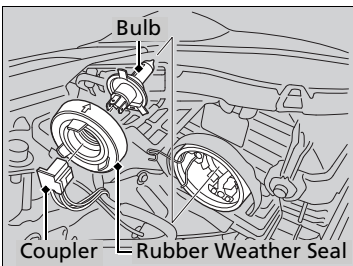

1. Remove the coupler.
2. Remove the rubber weather seal.

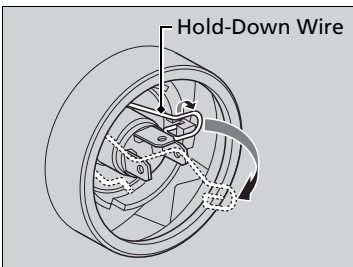

3. Remove the hold-down wire, then remove the bulb.
4. Insert a new bulb.

### Headlight Bulbs

#### NOTICE

Halogen bulbs get very hot when lit. Oil, perspiration, or a scratch on the glass can cause the bulb to overheat and shatter.

The headlight aim is set by the factory, and does not need to be adjusted. However, if you regularly carry heavy items in the cargo area, have the aiming readjusted at an authorized Honda Fit EV dealer or by a qualified technician.

The HB2 type is halogen bulb. When replacing a bulb, handle it by its base, and protect the glass from contact with your skin or hard objects. If you touch the glass, clean it with denatured alcohol and a clean cloth.

The exterior lights' inside lenses (headlights, brake lamps, etc.) may fog temporarily after a vehicle wash or while driving in the rain. This does not impact the exterior light function.

However, if you see a large amount of water or ice accumulated inside the lenses, have your vehicle inspected by an authorized Honda Fit EV dealer.

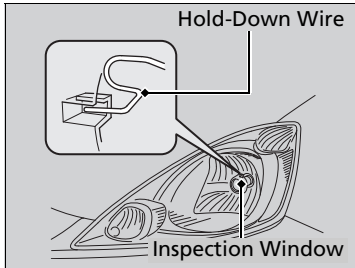

5. Reinstall the hold-down wire. Hook the end of the wire on the knob in the slot.
  - ▶ You can see if the hold-down wire is in the right place from the inspection window.
6. Reinstall the rubber weather seal.
7. Insert the coupler into the connector of the bulb.

## Front Turn Signal Light Bulbs

When replacing, use the following bulbs.

**Front Turn Signal Light: 21 W (Amber)**

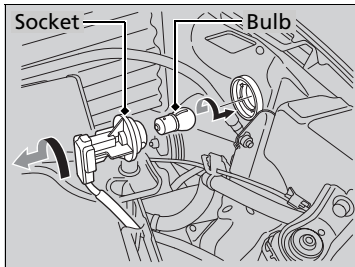

1. Turn the socket to the left and remove it.
2. Push in the old bulb, rotate to the left until it unlocks, and remove.
3. Insert a new bulb.

## Parking/Side Marker Light Bulbs

When replacing, use the following bulbs.

**Parking/Side Marker Light: 3.8 W (Amber)**

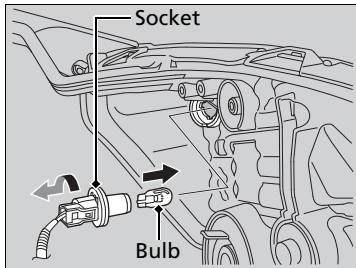

1. Turn the socket to the left and remove it.
2. Remove the old bulb and insert a new bulb.

## Back-Up Light and Rear Turn Signal Light Bulbs

When replacing, use the following bulbs.

**Back-Up Light: 16 W**  
**Rear Turn Signal Light: 21 W (Amber)**

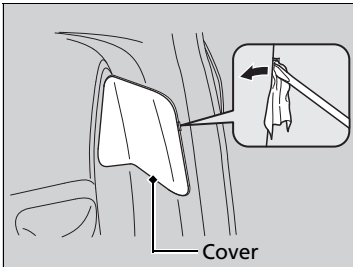

1. Pry on the edge of the cover using a flat-tip screwdriver to remove the cover.
  - ▶ Wrap the flat-tip screwdriver with a cloth to prevent scratches.

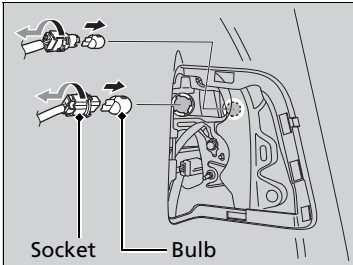

2. Turn the socket to the left and remove it. Remove the old bulb.
3. Insert a new bulb.

## Brake/Taillight Bulbs

Brake/rear taillight bulbs are LED type. Have an authorized Honda Fit EV dealer inspect and replace the light bulbs.

## High-Mount Brake Light Bulb

High-mount brake light bulbs are LED type. Have an authorized Honda Fit EV dealer inspect and replace the light bulbs.

## Rear License Plate Light Bulb

When replacing, use the following bulb.

**Rear License Plate Light: 5 W**

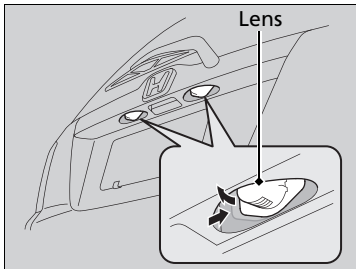

1. Push the lens to the right and pull out the lens and the socket attached to it.

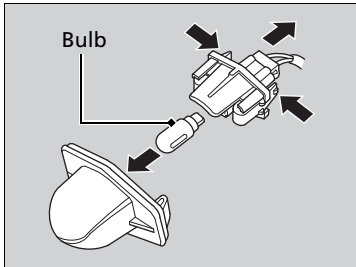

2. Remove the license plate light assembly by squeezing the tabs on both sides of the socket.
3. Remove the old bulb and insert a new bulb.

## Checking Wiper Blades

If the wiper blade rubber has deteriorated, it will leave streaks and the metal wiper arm may scratch the window glass.

## Changing the Front Wiper Blade Rubber

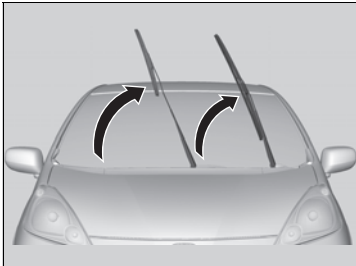

1. Lift the driver side wiper arm first, then the passenger side.

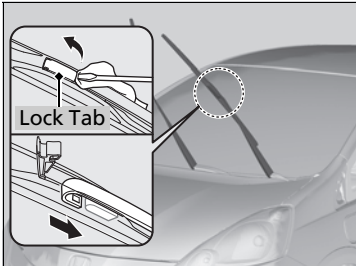

2. Place a cloth on the edge of the lock tab. Push the lock tab up with a flat-tip screwdriver.
3. Slide the blade from the wiper arm.

### ✘ Changing the Front Wiper Blade Rubber

#### NOTICE

Avoid dropping the wiper arm; it may damage the windshield.



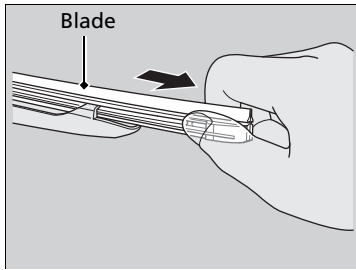

4. Slide the wiper blade out from its holder by pulling the tabbed end out.

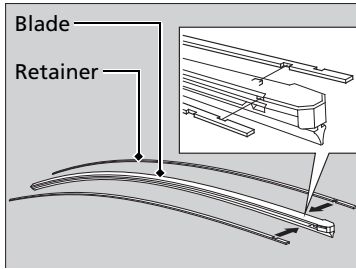

5. Remove the retainers from the rubber blade that has been removed, and mount to a new rubber blade.
  - ▶ Correctly align the rubber protrusion and the retainer grooves.

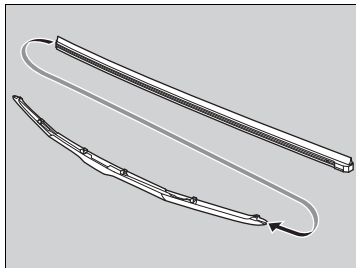

6. Slide the new wiper blade onto the holder from the bottom end.
  - ▶ The tab on the holder should fit in the indent of the wiper blade.
7. Slide the wiper blade onto the wiper arm, then push down the lock tab.
8. Lower the passenger side wiper arm first, then the driver side.

## Changing the Rear Wiper Blade Rubber

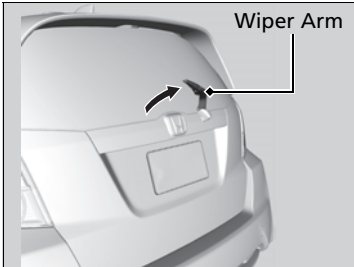

1. Raise the wiper arm off.

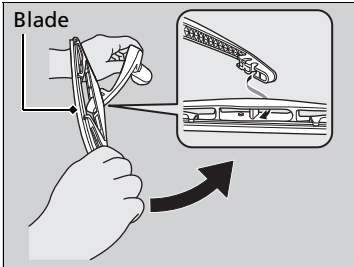

2. Pivot up the bottom end of the wiper blade until it comes off from the wiper arm.

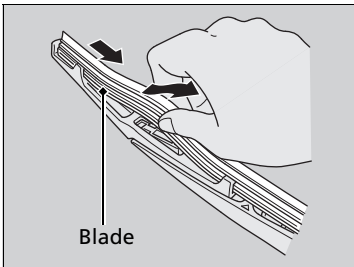

3. Slide the wiper blade out from the end with the indent.

### Changing the Rear Wiper Blade Rubber

#### NOTICE

Avoid dropping the wiper blade; it may damage the rear window.

Continued

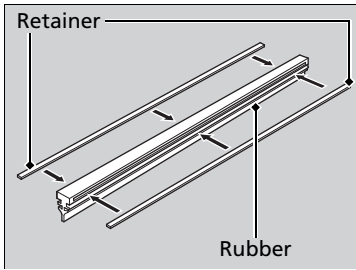

**4.** Remove the retainers from the rubber blade that has been removed, and mount to a new rubber blade.

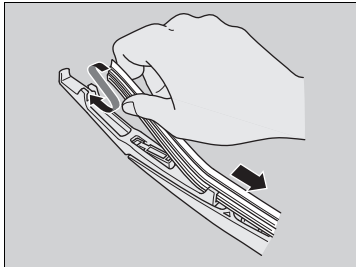

**5.** Slide the wiper blade onto the holder.  
▶ Make sure it is engaged correctly, then install the wiper blade assembly onto the wiper arm.

## Checking Tires

To safely operate your vehicle, your tires must be of the proper type and size, in good condition with adequate tread, and properly inflated.

### ■ Inflation guidelines

Properly inflated tires provide the best combination of handling, tread life, and comfort. Refer to the driver's doorjamb label or specification's page for the specified pressure.

Underinflated tires wear unevenly, adversely affect handling and fuel economy, and are more likely to fail from overheating.

Overinflated tires make your vehicle ride harshly, are more prone to road hazards, and wear unevenly.

Every day before you drive, look at each of the tires. If one looks lower than the others, check the pressure with a tire gauge.

At least once a month or before long trips, use a gauge to measure the pressure in all tires, including a spare. Even tires in good condition can lose 1 to 2 psi (10 to 20 kPa, 0.1 to 0.2 kgf/cm<sup>2</sup>) per month.

### ■ Inspection guidelines

Every time you check inflation, also examine the tires and valve stems.

Look for:

- Bumps or bulges on the side or in the tread. Replace the tire if you find any cuts, splits, or cracks in the side of the tire. Replace it if you see fabric or cord.
- Remove any foreign objects and inspect for air leaks.
- Uneven tread wear. Have an authorized Honda Fit EV dealer check the wheel alignment.
- Excessive tread wear.

📄 **Wear Indicators** P. 216

- Cracks or other damage around valve stem.

### 🔍 Checking Tires

## ⚠️ WARNING

Using tires that are excessively worn or improperly inflated can cause a crash in which you can be seriously hurt or killed.

Follow all instructions in this owner's manual regarding tire inflation and maintenance.

Measure the air pressure when tires are cold. This means the vehicle has been parked for at least three hours, or driven less than 1 mile (1.6 km). If necessary, add or release air until the specified pressure is reached.

If checked when hot, tire pressure can be as much as 4–6 psi (30–40 kPa, 0.3–0.4 kgf/cm<sup>2</sup>) higher than if checked when cold.

Have an authorized Honda Fit EV dealer check the tires if you feel a consistent vibration while driving. New tires and any that have been removed and reinstalled should be properly balanced.

## Tire and Loading Information Label

The label attached to the driver’s doorjamb provides necessary tire and loading information.

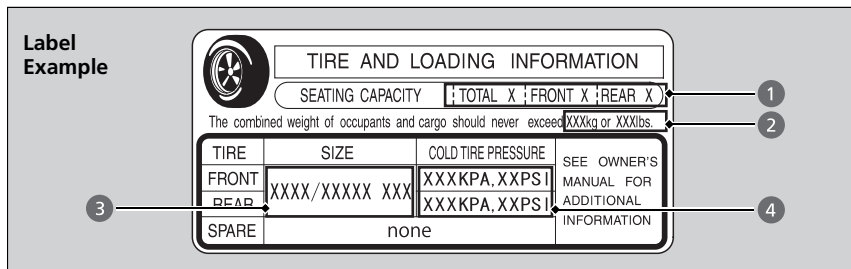

### ▶▶ Tire and Loading Information Label

The tire and loading information label attached to the driver’s doorjamb contains:

- 1 The number of people your vehicle can carry.
- 2 The total weight your vehicle can carry. Do not exceed this weight.
- 3 The original tire sizes for front, rear, and spare.
- 4 The proper cold tire pressure for front and rear.

## Tire Labeling

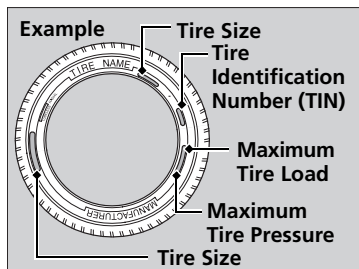

The tires that came on your vehicle have a number of markings. Those you should be aware of are described below.

### ▶▶ Tire Sizes

Following is an example of tire size with an explanation of what each component means.

#### **185/65R15 88H**

- 185: Tire width in millimeters.
- 65: Aspect ratio (the tire’s section height as a percentage of its width).
- R: Tire construction code (R indicates radial).
- 15: Rim diameter in inches.
- 88: Load index (a numerical code associated with the maximum load the tire can carry).
- H: Speed symbol (an alphabetical code indicating the maximum speed rating).

### Tire Sizes

Whenever tires are replaced, they should be replaced with tires of the same size.

## ■ Tire Identification Number (TIN)

The tire identification number (TIN) is a group of numbers and letters that look like the example in the side column. TIN is located on the sidewall of the tire.

## ■ Glossary of Tire Terminology

**Cold Tire Pressure** – The tire air pressure when the vehicle has been parked for at least three hours or driven less than 1 mile (1.6 km).

**Load Rating** – Means the maximum load that a tire is rated to carry for a given inflation pressure.

**Maximum Inflation Pressure** – The maximum tire air pressure that the tire can hold.

**Maximum Load Rating** – Means the load rating for a tire at the maximum permissible inflation pressure for that tire.

**Recommended Inflation Pressure** – The cold tire inflation pressure recommended by the manufacturer.

**Treadwear Indicators (TWI)** – Means the projections within the principal grooves designed to give a visual indication of the degrees of wear of the tread.

### ☒ Tire Identification Number (TIN)

For example:

**DOT B97R FW6X 2209**

DOT: This indicates that the tire meets all requirements of the U.S. Department of Transportation.

B97R: Manufacturer's identification mark.

FW6X: Tire type code.

22 09: Date of manufacture.

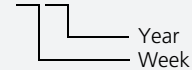

## DOT Tire Quality Grading (U.S. Vehicles)

The tires on your vehicle meet all U.S. Federal Safety Requirements. All tires are also graded for treadwear, traction, and temperature performance according to Department of Transportation (DOT) standards. The following explains these gradings.

### ■ Uniform Tire Quality Grading

Quality grades can be found where applicable on the tire sidewall between tread shoulder and maximum section width.

### ■ Treadwear

The treadwear grade is a comparative rating based on the wear rate of the tire when tested under controlled conditions on a specified government test course. For example, a tire graded 150 would wear one and one-half (1 1/2) times as well on the government course as a tire graded 100. The relative performance of tires depends upon the actual conditions of their use, however, and may depart significantly from the norm due to variations in driving habits, service practices and differences in road characteristics and climate.

### ▣ Uniform Tire Quality Grading

For example:  
**Treadwear 200**  
**Traction AA**  
**Temperature A**

All passenger car tires must conform to Federal Safety Requirements in addition to these grades.

## ■ Traction

The traction grades, from highest to lowest, are AA, A, B, and C. Those grades represent the tire's ability to stop on wet pavement as measured under controlled conditions on specified government test surfaces of asphalt and concrete. A tire marked C may have poor traction performance.

## ■ Temperature

The temperature grades are A (the highest), B, and C, representing the tire's resistance to the generation of heat and its ability to dissipate heat when tested under controlled conditions on a specified indoor laboratory test wheel. Sustained high temperature can cause the material of the tire to degenerate and reduce tire life, and excessive temperature can lead to sudden tire failure. The grade C corresponds to a level of performance which all passenger car tires must meet under the Federal Motor Vehicle Safety Standard No. 109. Grades B and A represent higher levels of performance on the laboratory test wheel than the minimum required by law.

### ⌘ Traction

Warning: The traction grade assigned to this tire is based on straight-ahead braking traction tests, and does not include acceleration, cornering, hydroplaning, or peak traction characteristics.

### ⌘ Temperature

Warning: The temperature grade for this tire is established for a tire that is properly inflated and not overloaded. Excessive speed, underinflation, or excessive loading, either separately or in combination, can cause heat buildup and possible tire failure.



## Wear Indicators

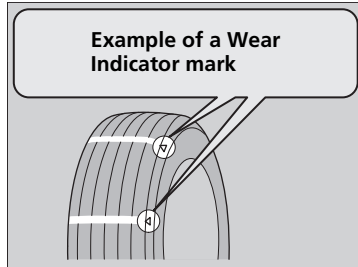

The groove where the wear indicator is located is 1/16 inch (1.6 mm) shallower than elsewhere on the tire. If the tread has worn so that the indicator is exposed, replace the tire.

**Worn out tires have poor traction on wet roads.**

## Tire Service Life

The life of your tires is dependent on many factors, including driving habits, road conditions, vehicle loading, inflation pressure, maintenance history, speed, and environmental conditions (even when the tires are not in use).

In addition to regular inspections and inflation pressure maintenance, it is recommended that you have annual inspections performed once the tires reach five years old. All tires, should be removed from service after 10 years from the date of manufacture, regardless of their condition or state of wear.

## Tire and Wheel Replacement

Replace your tires with radials of the same size, load range, speed rating, and maximum cold tire pressure rating (as shown on the tire's sidewall). Using tires of a different size or construction can cause the ABS and VSA® (vehicle stability assist) system to work incorrectly.

It is best to replace all four tires at the same time. If that isn't possible, replace the front or rear tires in pairs.

Make sure that the wheel's specifications match those of the original wheels.

If you replace a wheel, only use TPMS specified wheels approved for your vehicle.

### ⚠ Tire and Wheel Replacement

#### **⚠ WARNING**

Installing improper tires on your vehicle can affect handling and stability. This can cause a crash in which you can be seriously hurt or killed.

Always use the size and type of tires recommended in this owner's manual.

## Tire Rotation

Rotating tires according to the Maintenance Schedule helps to distribute wear more evenly and increase tire life.

### ■ Tires without rotation marks

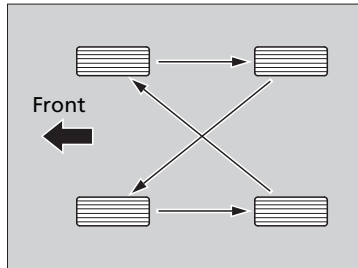

Rotate the tires as shown here.

### ■ Tires with rotation marks

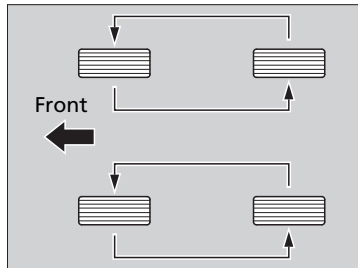

Rotate the tires as shown here.

### ▶▶ Tire Rotation

Tires with directional tread patterns should only be rotated front to back (not from one side to the other). Directional tires should be mounted with the rotation indication mark facing forward, as shown below.

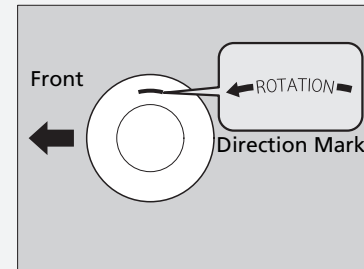

## Winter Tires

If driving on snowy or frozen roads, mount all season marked “M+S” tires, snow tires, or tire chains; reduce speed; and maintain sufficient distance between vehicles when driving.

Be particularly careful when operating the steering wheel or brakes to prevent skidding.

Use tire chains, snow tires, or all season tires when necessary or according to the law.

When mounting, refer to the following points.

For winter tires:

- Select the size and load ranges that are the same as the original tires.
- Mount the tires to all four wheels.

For tire chains:

- Install them on the front tires only.
- Because your vehicle has limited tire clearance, we strongly recommend using the chains listed below:

**Cable-type: SCC Radial Chain SC1026**

- Follow the chain manufacturer’s instruction when installing. Mount them as tightly as you can.
- Check that the chains do not touch the brake lines or suspension.
- Drive slowly.

### ❗ Winter Tires

## ⚠ WARNING

Using the wrong chains, or not properly installing chains, can damage the brake lines and cause a crash in which you can be seriously injured or killed.

Follow all instructions in this owner’s manual regarding the selection and use of tire chains.

### NOTICE

Traction devices that are the wrong size or improperly installed can damage your vehicle’s brake lines, suspension, body, and wheels. Stop driving if they are hitting any part of the vehicle.

When tire chains are mounted, follow the chain manufacturer’s instructions regarding vehicle operational limits.

If your vehicle is equipped with summer tires, be aware that these tires are not designed for winter driving conditions. For more information, contact an authorized Honda Fit EV dealer.

## Checking the 12 Volt Battery

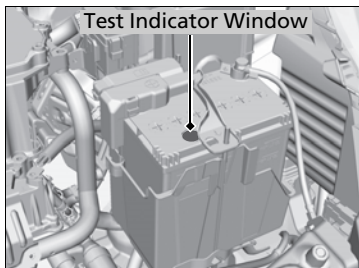

Check the battery condition monthly. Look at the test indicator window and check the terminals for corrosion.

If your vehicle's battery is disconnected or goes dead:

- The navigation system is disabled.
  - **Refer to the navigation system manual**

## Charging the 12 Volt Battery

Disconnect both battery cables to prevent damaging your vehicle's electrical system. Always disconnect the negative (-) cable first, and reconnect it last.

### 12 Volt Battery

#### **⚠ WARNING**

The battery gives off explosive hydrogen gas during normal operation.

A spark or flame can cause the battery to explode with enough force to kill or seriously hurt you.

When conducting any battery maintenance, wear protective clothing and a face shield, or have a skilled technician do it.

**WARNING:** Battery post, terminals, and related accessories contain lead and lead compounds.

**Wash your hands after handling.**

The test indicator's color information is on the battery.

When you find corrosion, clean the battery terminals by applying a baking powder and water solution. Rinse the terminals with water. Cloth/towel dry the battery. Coat the terminals with grease to help prevent future corrosion.

## Replacing the Battery

If the indicator does not come on when the button is pressed, replace the battery.

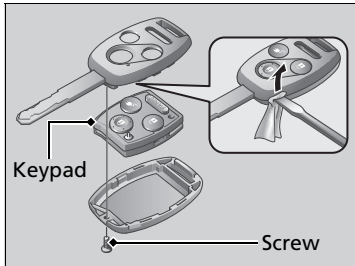

### Battery type: CR1616

1. Unscrew the cover with a small Phillips-head screwdriver.
  - ▶ Wrap the small flat-tip screwdriver with a cloth to prevent scratching the transmitter.
2. Open the keypad.
  - ▶ Wrap a coin with a cloth to prevent scratching the transmitter.
3. Make sure to replace the battery with the correct polarity.

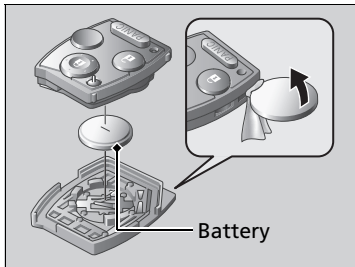

### Replacing the Battery

#### NOTICE

An improperly disposed of battery can damage the environment. Always confirm local regulations for battery disposal.

Replacement batteries are commercially available or at an authorized Honda Fit EV dealer.

## Replacing the Battery

If the low battery indicator comes on when the button is pressed, replace the battery.

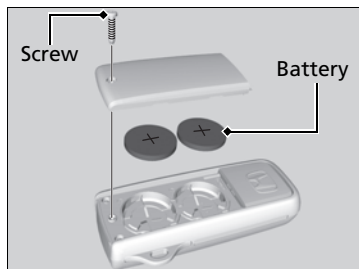

### Battery type: CR2032

1. Unscrew the cover with a small Phillips-head screwdriver.
2. Remove the cover.
3. Make sure to replace the new battery with the correct polarity.

### Replacing the Battery

#### NOTICE

An improperly disposed of battery can damage the environment. Always confirm local regulations for battery disposal.

Replacement batteries are commercially available or at an authorized Honda Fit EV dealer.

Make sure to replace the two batteries at once.

## Air Conditioning

To ensure proper and safe operation, the Society of Automotive Engineers (SAE J2845) recommends that the refrigerant system only be serviced by trained and certified technicians.

Never repair or replace the air conditioning evaporator (cooling coil) with one removed from a used or salvaged vehicle.

New replacement mobile air conditioning evaporators must be certified (and labeled) as meeting SAE Standard J2842.

## Dust and Pollen Filter

The climate control system is equipped with a dust and pollen filter that collects pollen, dust, and other debris in the air. Replace the dust and pollen filter according to your vehicle's recommended maintenance schedule.

We recommend that you replace the dust and pollen filter sooner when using your vehicle in areas with high concentrations of dust.

### Climate Control System Maintenance

#### NOTICE

Vented refrigerant is harmful to the environment. To avoid refrigerant from venting, never replace the evaporator with one removed from a used or salvaged vehicle.

Refrigerant in your vehicle's air conditioning system is flammable and can be ignited during servicing if proper procedures are not followed.

The following label is found under the hood:

 : Caution



 : Flammable Refrigerant

 : Requires a qualified technician to service

 : See the Service Manual

 **Specifications** P. 254

### Dust and Pollen Filter

If the airflow from the climate control system deteriorates noticeably, and the windows fog up easily, the filter may need to be replaced. Please contact an authorized Honda Fit EV dealer for replacement.



## Interior Care

Use a damp cloth with a mixture of mild detergent and warm water to remove dirt. Use a clean cloth to remove detergent residue.

### Cleaning Seat Belts

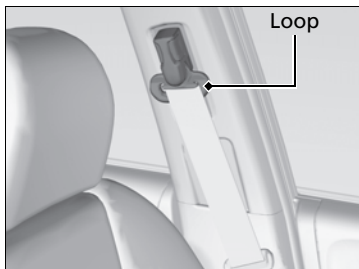

Use a soft brush with a mixture of mild soap and warm water to clean the seat belts. Let the belts air dry. Wipe the loop of the seat belt anchors using a clean cloth.

### Floor Mats

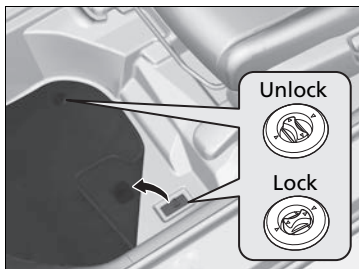

The driver's floor mat hooks over the floor anchors, which keep the mat from sliding forward. To remove a mat for cleaning, turn the anchor knobs to the unlock position. When reinstalling the mat after cleaning, turn the knobs to the lock position.

**Do not put additional floor mats on top of the anchored mat.**

### Control Box

When the control box gets dirty, wipe the dirt with a soft cloth.

### Interior Care

Do not spill liquids inside the vehicle. Electrical devices and systems may malfunction if liquids are splashed on them.

Do not use silicone based sprays on electrical devices such as audio devices and switches. Doing so may cause the items to malfunction or a fire inside the vehicle. If a silicone based spray is inadvertently used on electrical devices, consult an authorized Honda Fit EV dealer.

Depending on their composition, chemicals and liquid aromatics may cause discoloration, wrinkles, and cracking to resin-based parts and textiles. Do not use alkali solvents or organic solvents such as benzene or gasoline.

After using chemicals, make sure to gently wipe them off using a dry cloth. Do not place used cloths on top of resin based parts or textiles for long periods of time without washing.

### Floor Mats

If you use any floor mats that were not originally provided with your vehicle, make sure they are designed for your specific vehicle, fit correctly, and are securely anchored by the floor anchors. Position the rear seat floor mats properly. If they are not properly positioned, the floor mats can interfere with the front seat functions.

## Exterior Care

Dust off the vehicle body after you drive.

Regularly inspect your vehicle for scratches on painted surfaces. A scratch on a painted surface can result in body rust. If you find a scratch, promptly repair it.

### ■ Washing the Vehicle

Wash the vehicle regularly. Wash more frequently when driving in the following conditions:

- If driving on roads with road salt.
- If driving in coastal areas.
- If tar, soot, bird droppings, insects, or tree sap are stuck to painted surfaces.

### ■ Using an Automated Car Wash

Fold in the door mirrors. Make sure to follow the instructions indicated on the automated car wash.

### ■ Using High Pressure Cleaners

- Keep sufficient distance between the cleaning nozzle and the vehicle body.
- Do not spray water under the hood where the electric motor and other high voltage system components are located. It could cause a malfunction.
- Do not spray water directly at the charging port.
- Do not spray water into the climate control system front air intake vents.
- Take particular care around the windows. Standing too close may cause water to enter the vehicle interior. Do not spray water into the motor compartment.

### ▶▶ Washing the Vehicle

If the airflow from the climate control system deteriorates noticeably, and the windows fog up easily, the filter may need to be replaced. Please contact an authorized Honda Fit EV dealer for replacement.

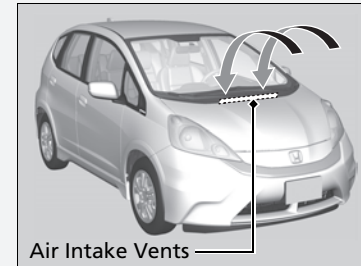

## ■ Applying Wax

A good coat of automotive body wax helps protect your vehicle's paint from the elements. Wax will wear off over time and expose your vehicle's paint to the elements, so reapply as necessary.

## ■ Maintaining the Bumpers and Other Resin Coated Parts

If you get gasoline, oil, coolant, or battery fluid on resin coated parts, they may be stained or the coating may peel. Promptly wipe it away using a soft cloth and clean water.

## ■ Cleaning the Window

Wipe using a glass cleaner.

## ■ Maintaining Aluminum Wheels

Aluminum is susceptible to deterioration caused by salt and other road contaminants. Use a sponge and mild detergent to wipe away promptly. Be careful not to use harsh chemicals (including some commercial wheel cleaners) or a stiff brush. They can damage the clear coat of the aluminum alloy wheels that helps keep the aluminum from corroding and tarnishing.

### ☒ Applying Wax

#### NOTICE

Chemical solvents and strong cleaners can damage the paint, metal, and plastic on your vehicle. Wipe up spills immediately.

### ☒ Maintaining the Bumpers and Other Resin Coated Parts

Ask an authorized Honda Fit EV dealer about the correct coating material when you want to repair the painted surface of the parts made of resin.

### ☒ Cleaning the Window

Wires are mounted to the inside of the rear window. Wipe along the same direction as the wires with a soft cloth so as not to damage them.

# Handling the Unexpected

This chapter explains how to handle unexpected troubles.

<b>Tools</b>	
Types of Tools.....	228
<b>If a Tire Goes Flat</b>	
Temporarily Repairing a Flat Tire .....	229
<b>Power System Won't Start</b>	
Checking the Procedure.....	237
<b>Jump Starting</b> .....	238
<b>Shift Lever Does Not Move</b> .....	240
<b>Overheating</b>	
How to Handle Overheating.....	241
<b>Indicator, Coming On/Blinking</b>	
If the 12 Volt Battery Charging System Indicator Comes On .....	242
If the Brake Warning Indicator Comes On ..	243
If the EPS System Indicator Comes On...243	
If the Low Tire Pressure/TPMS Indicator Comes On or Blinks .....	244
<b>Fuses</b>	
Fuse Locations .....	245
Inspecting and Changing Fuses.....	249
<b>Emergency Towing</b> .....	250
<b>When You Cannot Open the Tailgate</b> ..	251
<b>When You Cannot Open the Charge Lid</b> ..	252

## Types of Tools

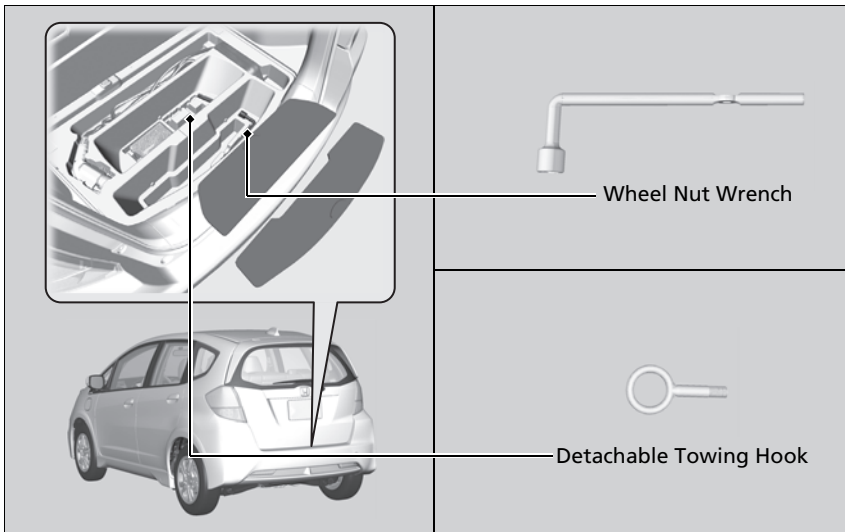

### Types of Tools

The tools are stored in the cargo area.

## Temporarily Repairing a Flat Tire

If the tire has a large cut or is otherwise severely damaged, you will need to have the vehicle towed. If the tire only has a small puncture, from a nail for instance, you can use the temporary tire repair kit so that you can drive to the nearest service station for a more permanent repair.

If a tire goes flat while driving, grasp the steering wheel firmly, and brake gradually to reduce speed. Then stop in a safe place.

1. Park the vehicle on firm, level, non-slippery surface and apply the parking brake.
2. Put the shift lever in **P**.
3. Turn on the hazard warning lights and turn the power switch to LOCK **0**.

### Temporarily Repairing a Flat Tire

The kit should not be used in the following situations. Instead, contact an authorized Honda Fit EV dealer or a roadside assistant to have the vehicle towed.

- The tire sealant has expired.
- More than two tires are punctured.
- The puncture or cut is larger than 3/16 inch (4 mm) in cut.
- The tire side wall is damaged or the puncture is outside the contact area.



When the puncture is:	Kit Use
Smaller than 3/16 inch (4 mm)	Yes
Larger than 3/16 inch (4 mm)	No

- Damage has been caused by driving with the tires extremely under inflated.
- The tire bead is no longer seated.
- A rim is damaged.

Do not remove a nail or screw that punctured the tire. If you remove it from the tire, you may not be able to repair the puncture using the kit.

#### NOTICE

Do not use a puncture-repairing agent other than the one provided in the kit that came with your vehicle. If a different agent is used, you may permanently damage the tire pressure sensor.

## ■ Getting Ready to Temporarily Repair the Flat Tire

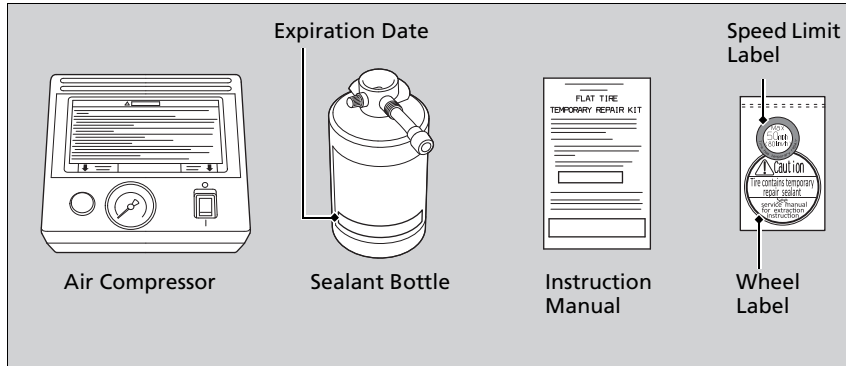

## ▶▶ Getting Ready to Temporarily Repair the Flat Tire

When making a temporary repair, carefully read the instruction manual provided with the kit.

1. Pull up the strap and open the cargo area floor lid.
2. Take the lid.
3. Take the kit out of the case.
4. Place the kit, face up, on flat ground near the flat tire, away from traffic. Do not place the kit on its side.

## Injecting Sealant and Air

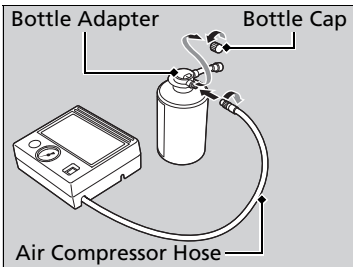
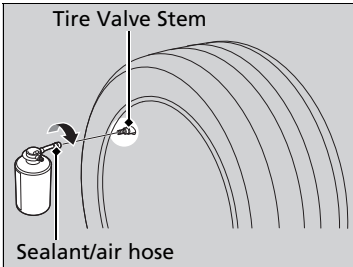
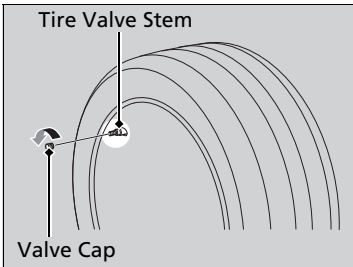

**1.** Remove the valve cap from the tire valve stem.

**2.** Shake the sealant bottle.

**3.** Attach the sealant/air hose onto the tire valve stem. Screw it until it is tight.

► Make sure the bottle remains upright to ensure all of the sealant flows into the tire.

**4.** Remove the bottle cap from the bottle adapter.

**5.** Attach the air compressor hose onto the bottle adapter. Screw it until it is tight.

### Injecting Sealant and Air

In cold temperatures, the sealant may not flow easily. In this situation, warm it up for five minutes before using.

The sealant can permanently stain clothing and other materials. Be careful during handling and wipe away any spills immediately.



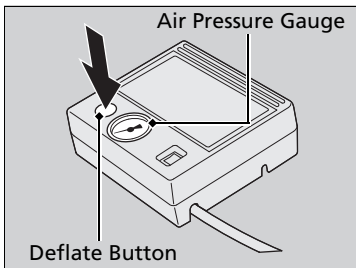
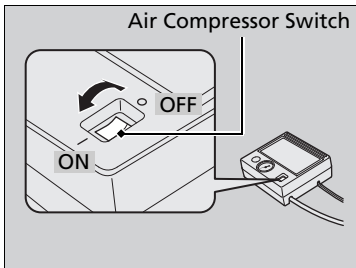
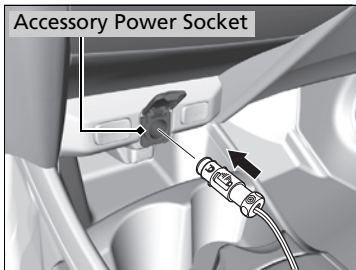

6. Plug in the compressor to the accessory power socket.

▶ Be careful not to pinch the cord in a door or window.

▶ **Accessory Power Socket** P. 130

7. Turn the power switch to ACCESSORY **I**.

▶ In freezing temperatures, turn the power switch to ON **II**.

8. Turn the air compressor on to inflate the tire.

▶ The compressor starts injecting sealant and air into the tire.

9. After the air pressure reaches 32 psi (220 kPa), turn off the kit.

▶ Check the air pressure gauge on the air compressor.

10. Unplug the kit from the accessory power socket.

11. Unscrew the sealant/air hose from the tire valve stem. Reinstall the valve cap.

12. Push the deflate button until the gauge returns 0 psi.

### ▶▶ Injecting Sealant and Air

#### NOTICE

Do not operate the tire repair kit compressor for more than 15 minutes. The compressor can overheat and become permanently damaged.

Until the sealant injection is complete, the pressure shown on the pressure gauge will appear higher than actual. After the sealant injection is complete the pressure will drop and then begin to rise again as the tire is inflated with air. This is normal. To accurately measure the air pressure using the gauge, turn the air compressor off only after the sealant injection is complete.

If the required air pressure is not reached within 15 minutes, the tire may be too severely damaged for the kit to provide the necessary seal and your vehicle will need to be towed.

See an authorized Honda Fit EV dealer for a replacement sealant bottle and proper disposal of an empty bottle.

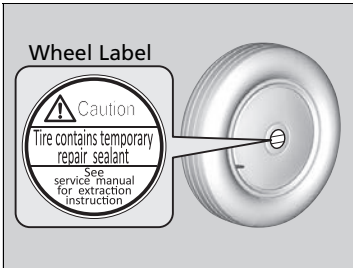

13. Apply the wheel label to the flat surface of the wheel.
  - The wheel surface must be clean to ensure the label adheres properly.

### ■ Distributing the Sealant in the Tire

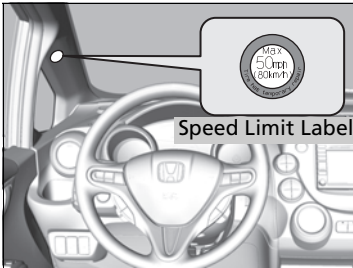

1. Apply the speed limit label to the location as shown.
2. Drive the vehicle for about five minutes.
  - Do not exceed 50 mph (80 km/h).
3. Stop the vehicle in a safe place.

### ▣ Distributing the Sealant in the Tire

Stop and recheck the air pressure after every five minutes of driving as necessary until you reach the nearest service station where you should have the tire permanently repaired or replaced.

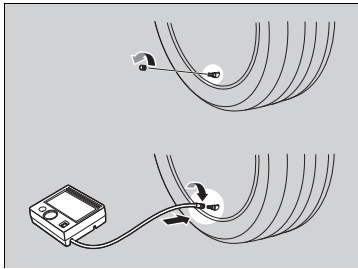

4. Recheck the air pressure using the gauge on the air compressor.
  - ▶ Do not turn the air compressor on to check the pressure.
5. If the air pressure is
  - Less than 19 psi (130 kPa):  
Do not add air and/or continue driving. The leak is too severe. Call for help and have your vehicle towed.
    - ✘ **Emergency Towing** P. 250
  - 32 psi (220 kPa) or more:  
Continue driving for another five minutes or until you reach the nearest service station. Do not exceed 50 mph (80 km/h).
    - ▶ If the air pressure does not go down after the five minute driving, you do not need to check the pressure any more.
  - Greater than 19 psi (130 kPa), but less than 32 psi (220 kPa):  
Add air using the pump until the tire pressure reaches 32 psi (220 kPa), then drive carefully for five more minutes or until you reach the nearest service station.
    - Do not exceed 50 mph (80 km/h).
    - ▶ You can repeat this procedure as long as the air pressure is within this range.
6. Repackage and properly stow the kit.

## ■ Inflating an Under-inflated Tire

You can use the kit to inflate a non-punctured under-inflated tire.

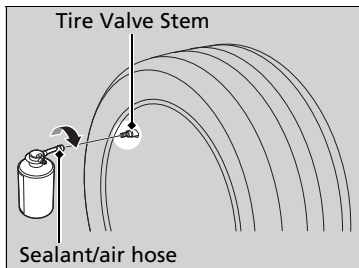
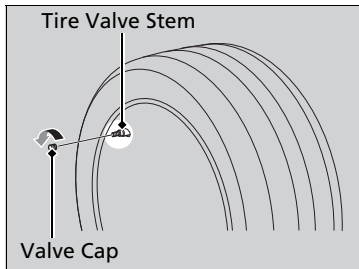
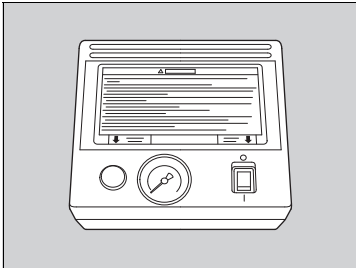

1. Pull up the strap and open the cargo area floor lid.
2. Take the lid.
3. Take the kit out of the case.
4. Place the kit, face up, on flat ground near the flat tire, away from traffic. Do not place the kit on its side.
5. Remove the valve cap.

6. Attach the air hose onto the tire valve stem. Screw it until it is tight.

## ►► Inflating an Under-inflated Tire

### NOTICE

Do not operate the temporary tire repair kit compressor for more than 15 minutes. The compressor can overheat and become permanently damaged.

*Continued*

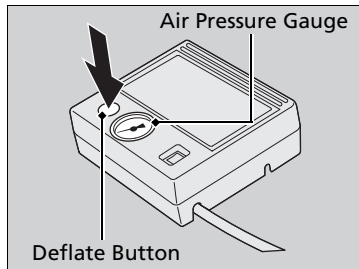
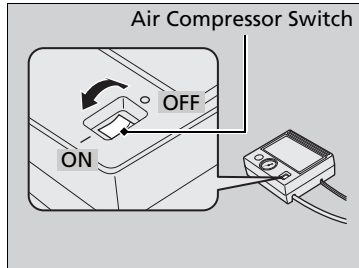
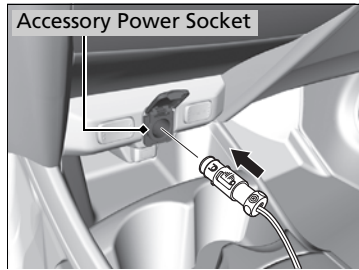

7. Plug in the compressor to the accessory power socket.
  - ▶ Be careful not to pinch the cord in a door or window.
  - ▶ **Accessory Power Socket** P. 130
8. Turn the power switch to ACCESSORY **I**.
  - ▶ In freezing temperatures, turn the power switch to ON **II**.
9. Turn the air compressor switch on to inflate the tire.
  - ▶ The compressor starts to inject air into the tire.
  - ▶ If you have started the power system, leave it running while injecting air.
10. Inflate the tire to the specified air pressure.
11. Turn off the kit.
  - ▶ Check the pressure gauge on the air compressor.
  - ▶ If overinflated, press the deflate button.
12. Unplug the kit from the accessory power socket.
13. Unscrew the air hose from the tire valve stem. Reinstall the valve cap.
14. Push the deflate button until the gauge returns 0 psi (0 kPa).
15. Repackage and properly stow the kit.

## Checking the Procedure

When the **READY TO DRIVE** message does not appear on the multi-information display, check the following items and take appropriate action.

### ☒ Checking the Procedure

If you must start the vehicle immediately, use an assisting vehicle to jump start it.

☒ **Jump Starting** P. 238

Checklist	Condition	What to Do
Check if the related indicator or multi-information display message come on	The plug in indicator comes on	Removing a charge connector. Set the power switch to ACCESSORY <b>I</b> , then set the switch to ON <b>II</b> .
	The <b>POWER REDUCED</b> indicator comes on	Charge the High Voltage battery. ☒ <b>Charging</b> P. 171
	The <b>POWER SYSTEM</b> indicator comes on	Have the vehicle checked by an authorized Honda Fit EV dealer.
Check the brightness of the interior lights	The interior lights are dim or do not come on at all	Have the 12 volt battery checked by an authorized Honda Fit EV dealer.
	The interior lights come on normally	Check all fuses, or have the vehicle checked by an authorized Honda Fit EV dealer. ☒ <b>Inspecting and Changing Fuses</b> P. 249
Check the select lever position	The shift lever is not in <b>P</b> or <b>N</b>	Move the shift lever to <b>P</b> position.

## Jump Starting Procedure

Turn off the power to electric devices, such as audio and lights. Turn off the power system, then open the hood.

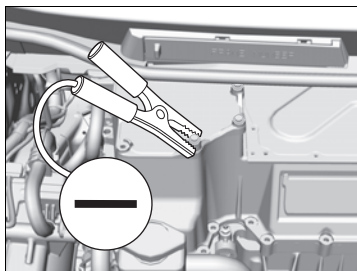
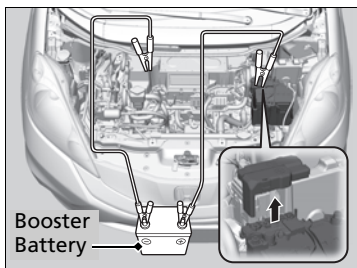

1. Connect the first jumper cable to your vehicle's battery  $\oplus$  terminal.
  - ▶ Remove the cover from the under-hood fuse box.
    - ❏ **Motor Compartment Fuse Box (On the 12V battery)** P. 245
2. Connect the other end of the first jumper cable to the booster battery  $\oplus$  terminal.
  - ▶ Use a 12-volt booster battery only.
3. Connect the second jumper cable to the booster battery  $\ominus$  terminal.
4. Connect the other end of the second jumper cable to the power system case underneath the bolt head as shown. Do not connect this jumper cable to any other part.
5. If your vehicle is connected to another vehicle, start the assisting vehicle's engine and increase its rpm slightly.
6. Attempt to start your vehicle's power system. If it isn't turn on, check that the jumper cables have good metal-to-metal contact.

## Jump Starting

### **WARNING**

A battery can explode if you do not follow the correct procedure, seriously injuring anyone nearby.

Keep all sparks, open flames, and smoking materials away from the battery.

Battery performance degrades in cold conditions and may prevent the power system from starting.

## ■ What to Do After the Power System Starts

Once your vehicle's power system has started, remove the jumper cables in the following order.

1. Disconnect the jumper cable from your vehicle's ground.
2. Disconnect the other end of the jumper cable from the booster battery ⊖ terminal.
3. Disconnect the jumper cable from your vehicle's battery ⊕ terminal.
4. Disconnect the other end of the jumper cable from the booster battery ⊕ terminal.

Have your vehicle inspected by a nearby service station or an authorized Honda Fit EV dealer.



# Shift Lever Does Not Move

Follow the procedure below if you cannot move the shift lever out of the **P** position.

## Releasing the Lock

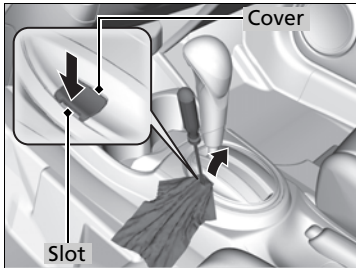

1. Set the parking brake.
2. Remove the key from the power switch.
3. Wrap a cloth around the tip of a small flat-tip screwdriver and remove the cover of the shift lock release slot.
  - ▶ Put the tip of the flat-tip screwdriver into the slot and remove it as shown in the image.

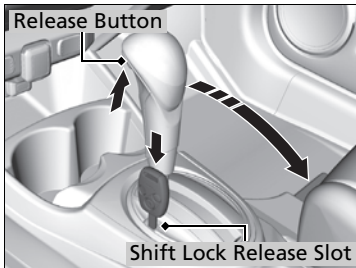

4. Insert the key into the shift lock release slot.
5. While pushing on the key, press the shift lever release button and place the shift lever into **N**.
  - ▶ The lock is now released. Have the shift lever checked by an authorized Honda Fit EV dealer as soon as possible.

## How to Handle Overheating

The **POWER REDUCED** indicator comes on and **HIGH TEMPERATURE. POWER REDUCED.** appears on the multi-information display when the power system temperature is high.

📖 **Indicators** P. 70

1. Immediately park the vehicle in a safe place.
  - ▶ Move the shift lever to **[P]**, and set the parking brake. Turn off all accessories and turn on the hazard warning lights.
2. Keep the power switch in ON **[II]**, and wait until the indicator goes off.
  - ▶ If the indicator does not go off, have the vehicle inspected at an authorized Honda Fit EV dealer.

### 📖 How to Handle Overheating

Keep the hood closed when cooling down the power system with the vehicle parked. If you open the hood, the radiator fan stops, making it take longer to cool the system down.

### If the 12 Volt Battery Charging System Indicator Comes On



#### ■ Reasons for the indicator to come on

Comes on when the 12 volt battery is not being charged.

#### ■ What to do when the indicator comes on

Turn off the climate control system, rear defogger, and other electrical systems, and immediately contact an authorized Honda Fit EV dealer for repairs.

#### ☒ If the 12 Volt Battery Charging System Indicator Comes On

The power system uses the 12 volt battery to activate. You may not be able to turn the power system on again if you have turned it off with this indicator on.

## If the Brake Warning Indicator Comes On



### ■ Reasons for the indicator to come on

- The brake fluid is low.
- There is a malfunction in the brake system.

### ■ What to do when the indicator comes on while driving

Press the brake pedal lightly to check pedal pressure.

- If normal, check the brake fluid level the next time you stop.
- If abnormal, take immediate action. If necessary, downshift the transmission to slow the vehicle using regenerative braking.

### ☒ If the Brake Warning Indicator Comes On

Have your vehicle repaired immediately. It is dangerous to drive with low brake fluid. If there is no resistance from the brake pedal, stop immediately in a safe place. If necessary downshift the transmission.

If the brake warning indicator and ABS indicator come on simultaneously, the electronic brake distribution system is not working. This can result in vehicle instability under sudden braking. Have your vehicle inspected by an authorized Honda Fit EV dealer immediately.

## If the EPS System Indicator Comes On



### ■ Reasons for the indicator to come on

- Comes on when there is a problem with EPS system.

### ■ What to do when the indicator comes on

Stop the vehicle in a safe place and turn on the power system again.

If the indicator comes on and stays on, immediately have your vehicle inspected by an authorized Honda Fit EV dealer.

### ☒ If the EPS System Indicator Comes On

#### NOTICE

If you repeatedly turn the steering wheel at an extremely low speed, or hold the steering wheel on the full left or right position for a while, the system heats up. The system goes into a protective mode, and limits its performance. The steering wheel becomes harder and harder to operate. Once the system cools down, EPS system is restored. Repeated operation under these conditions can eventually damage the system.

## If the Low Tire Pressure/TPMS Indicator Comes On or Blinks



### ■ Reasons for the indicator to come on or blink

A tire pressure is significantly low. If there is a problem with the TPMS, the indicator blinks for about one minute, and then stays on.

### ■ What to do when the indicator comes on

Stop your vehicle in a safe place. Check the tire pressure and adjust the pressure to the specified level. The specified tire pressure is on a label on the driver side doorjamb.

### ■ What to do when the indicator blinks

Have the tire inspected by an authorized Honda Fit EV dealer as soon as possible. If the compact spare tire causes the indicator to blink, change the tire to a full size tire. The indicator goes off after driving for a few miles.

### ▶▶ If the Low Tire Pressure/TPMS Indicator Comes On or Blinks

#### NOTICE

Driving on an extremely underinflated tire can cause it to overheat. An overheated tire can fail. Always inflate your tires to the prescribed level.

## Fuse Locations

If any electrical devices are not working, turn the power switch to LOCK **0** and check to see if any applicable fuse is blown.

Fuse locations are shown on the fuse box cover. Locate the fuse in question by the fuse number and box cover number.

### Motor Compartment Fuse Box (On the 12V battery)

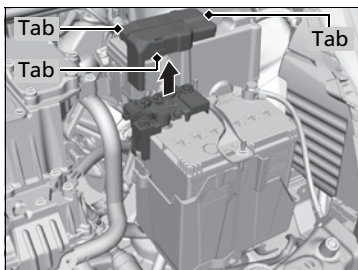

Pull up the cover by pushing the three tabs as shown.

Replacement of motor compartment fuses should be done by an authorized Honda Fit EV dealer.

#### ■ Circuit protected and fuse rating

	Circuit Protected	Amps
1	Battery	100 A
2	EPS	70 A
3	Horn/Stop/Hazard	20 A

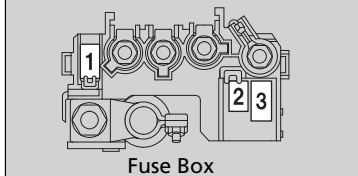

**Motor Compartment Fuse Box (Near the brake fluid reservoir)**

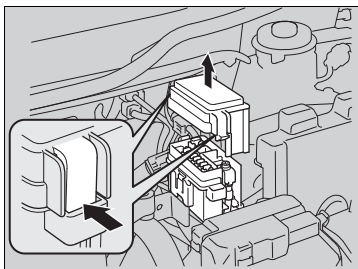

Push the tabs to open the box.

**■ Circuit protected and fuse rating**

	Circuit Protected	Amps
1	–	–
2	Battery Fan 1	15 A
3	Battery Fan 2	15 A
4	Electric Water Pump Heater	10 A
5	Electric Water Pump Cooling	7.5 A
6	Spare Fuse	15 A
7	Spare Fuse	10 A
8	Spare Fuse	7.5 A
9	Battery ECU	7.5 A
10	–	–
11	–	–

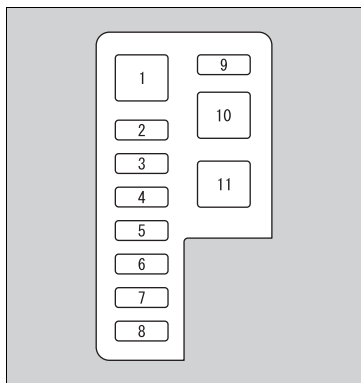

## Interior Fuse Box

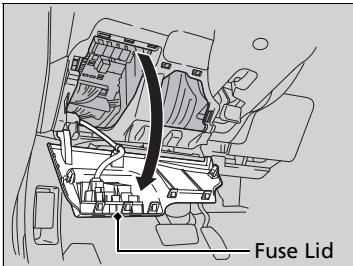

Located behind the fuse lid. Pull the fuse lid toward you.

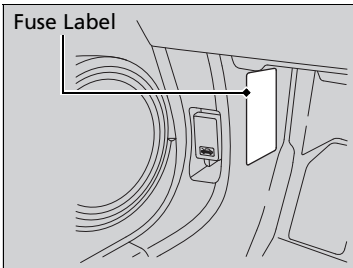

Fuse locations are shown on the label on the side panel.

Locate the fuse in question by the fuse number and label number.

## ■ Circuit protected and fuse rating

	Circuit Protected	Amps
1	Back Up	10 A
2	TPMS	7.5 A
3	Driver's Power Window	20 A
4	–	–
5	Back Up Light	10 A
6	SRS	10 A
7	E-Drive Immobilizer System	7.5 A
8	SRS	7.5 A
9	–	–
10	A/C	7.5 A
11	VSA	7.5 A
12	D/V	7.5 A
13	ACC Socket	20 A
14	Key Lock/Radio	7.5 A
15	Daytime Running Light	7.5 A
16	Rear Wiper	10 A
17	Front Passenger's Power Window	20 A
18	Rear Passenger's Side Power Window	20 A
19	Rear Driver's Side Power Window	20 A
20	–	–

	Circuit Protected	Amps
21	Washer	15 A
22	Meter	7.5 A
23	Hazard	10 A
24	Stop/Horn	10 A
25	–	–
26	E-Drive	7.5 A
27	Door Lock Main	30 A
28	Headlight Main	20 A
29	Small Light	10 A
30	Main Fan Motor	30 A
31	–	–
32	Passenger's Side Headlight Low Beam	10 A
33	–	–
34	Driver's Side Headlight Low Beam	10 A
35	Door Lock	15 A
36	Door Lock	15 A
37	VSA	30 A
38	Door Lock	15 A
39	E-Drive	10 A
40	Seat Heaters	20 A
41	E-Drive	7.5 A
42	–	–



	Circuit Protected	Amps
43	A/C Main	7.5 A
44	STS	7.5 A
45	Charge Lid	15 A
46	–	–
47	Sub Fan Motor	30 A
48	Driver's Side Headlight High Beam	10 A
49	Door Lock	15 A
50	Door Lock	15 A
51	Passenger's Side Headlight High Beam	10 A
52	E-Drive	7.5 A
53	–	–
54	–	–
55	–	–
56	Front Wiper	30 A
57	Blower Motor	30 A
58	VSA	30 A
59	Rear Defogger	20 A
60	IG Main/ ESB	50 A/ 40 A

## Inspecting and Changing Fuses

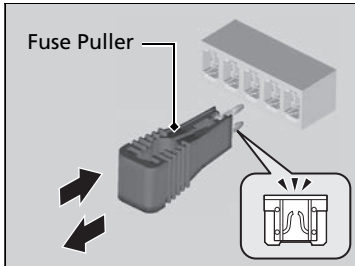
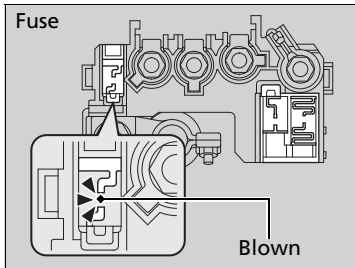

1. Turn the power switch to LOCK **0**. Turn headlights and all accessories off.
2. Check the fuses (on the 12 volt battery) in the motor compartment.
  - ▶ If the fuse is blown, have it replaced by an authorized Honda Fit EV dealer.
3. Inspect the small fuses in the motor compartment and the vehicle interior.
  - ▶ If there is a burned out fuse, remove it with the fuse puller and replace it with a new one.

### Inspecting and Changing Fuses

#### NOTICE

Replacing a fuse with one that has a higher rating greatly increases the chances of damaging the electrical system.

Replace fuse with a spare fuse of the same specified amperage.

Confirm the specified amperage using the charts on P. 245, 246 and P. 247.

There is a fuse puller on the interior fuse box.

Call a professional towing service if you need to tow your vehicle.

## ■ Flat bed equipment

The operator loads your vehicle on the back of a truck.

**This is the only way to transport your vehicle.**

## » Emergency Towing

### NOTICE

Trying to lift or tow your vehicle by the bumpers will cause serious damage. The bumpers are not designed to support the vehicle's weight.

### NOTICE

Improper towing such as towing behind a motorhome or other motor vehicle can damage the transmission.

# When You Cannot Open the Tailgate

## When You Cannot Open the Tailgate

If you cannot open the tailgate use the following procedure.

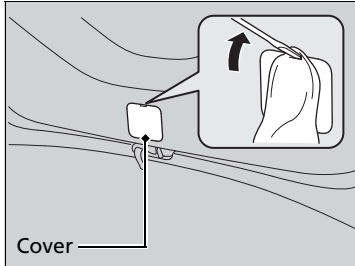

1. Wrap a cloth around the tip of a flat-tip screwdriver and remove the cover on the back of the tailgate.

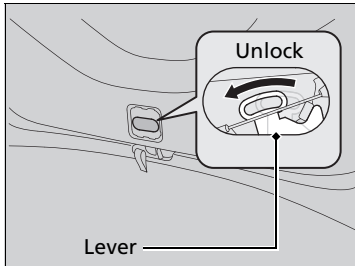

2. To open the tailgate, push the tailgate while pushing the lever to the unlocking direction.

## When You Cannot Open the Tailgate

What to do-Following up

After taking these steps, contact an authorized Honda Fit EV dealer to have the vehicle checked.

## ■ What to Do When Unable to Open the Charge Lid

If you cannot open the charge lid use the following procedure.

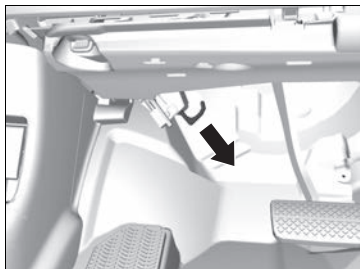

Pull the release lever under the lower left corner of the dashboard.

- ▶ The lid will pop up slightly.

## ▣ What to Do When Unable to Open the Charge Lid

After taking this step, contact an authorized Honda Fit EV dealer to have the vehicle checked.

# Information

This chapter includes your vehicle's specifications, locations of identification numbers, and other information required by regulation.

<b>Specifications</b> .....	254
<b>Identification Numbers</b>	
Vehicle Identification Number (VIN) ..	255
Motor Number .....	255
<b>Devices that Emit Radio Waves</b> .....	256
<b>Reporting Safety Defects</b> .....	257
<b>Warranty Coverages</b> .....	258
<b>Authorized Manuals</b> .....	259
<b>Customer Service Information</b> .....	260

## ■ Vehicle Specifications

Model	Honda Fit EV
No. of Passengers:	
Front	2
Rear	3
Total	5
<b>Weights:</b>	
Gross Vehicle Weight Rating	U.S.: 4,178 lbs (1,895 kg)
Gross Axle Weight Rating (Front)	U.S.: 2,083 lbs (945 kg)
Gross Axle Weight Rating (Rear)	U.S.: 2,183 lbs (990 kg)

## ■ 12 Volt Battery

Capacity/Type	28AH(5)/35AH(20)
---------------	------------------

## ■ Washer Fluid

Tank Capacity	2.1 US qt (2.0 ℓ)
---------------	-------------------

## ■ Light Bulbs

Headlights (High/Low Beam)	60/55W (HB2)
Parking/Side Marker Lights	3.8W (Amber)
Front Turn Signal Lights	21W (Amber)
Brake/Taillights	LED
Back-Up Lights	16W
Rear Turn Signal Lights	21W (Amber)
High-Mount Brake Light	LED
Rear License Plate Light	5W
Cargo Area Light	5W
<b>Interior Lights</b>	
Map Lights	8W
Ceiling Light	8W

## ■ Brake Fluid

Specified	Honda Heavy Duty Brake Fluid DOT 3
-----------	------------------------------------

## ■ Motor Coolant

Specified	Honda Long-Life Antifreeze/Coolant Type2
Ratio	50/50 with distilled water
Capacity	1.03 US gal (3.88 ℓ) (change including the remaining 0.12 US gal (0.44 ℓ) in the reserve tank)

## ■ Air Conditioning

Refrigerant Type	HFO-1234yf (R-1234yf)
Charge Quantity	13.2 – 15.0 oz (375 – 425 g)
Lubricant Type	ND-OIL11
Quantity	3.4 – 3.9 oz (96 – 111 g)

## ■ Tire

	Size	185/65R15 88H
Regular	Pressure	32 (220 [2.2])
	psi (kPa [kgf/cm <sup>2</sup> ])	
Wheel Size	Regular	15 x 6J

## Vehicle Identification Number (VIN)

Your vehicle has a 17-digit vehicle identification number (VIN) used to register your vehicle for warranty purposes, and for licensing and insuring your vehicle. See the image below for the VIN locations.

## Motor Number

See the image below for the location of your vehicle's motor number.

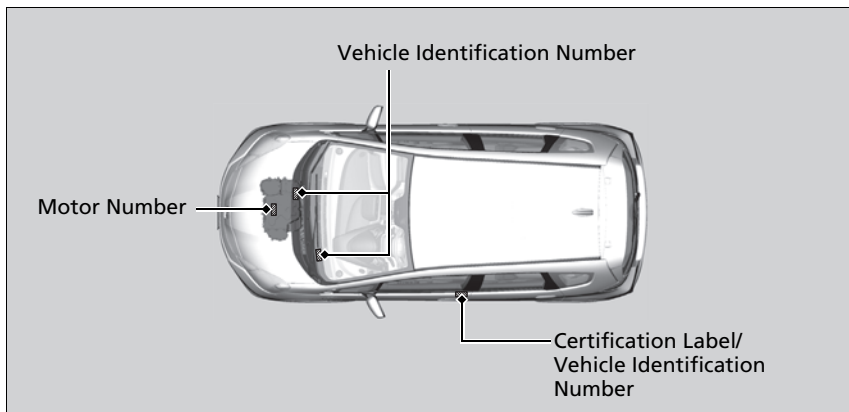



## Devices that Emit Radio Waves

The following products and systems on your vehicle emit radio waves when in operation.

Audio System	<i>Bluetooth</i> ® Audio
<i>Bluetooth</i> ® HandsFreeLink®	Immobilizer System
Remote Transmitter	Tire Pressure Monitoring System (TPMS)
Interactive Remote Control	Charging Cable

Each of the above complies with the appropriate requirements or the required standards of FCC (Federal Communications Commission) described below:

As required by the FCC:

This device complies with Part 15 of the FCC rules. Operation is subject to the following two conditions: (1) This device may not cause harmful interference, and (2) this device must accept any interference received, including interference that may cause undesired operation.

Changes or modifications not expressly approved by the party responsible for compliance could void the user's authority to operate the equipment.

In the U.S.

If you believe that your vehicle has a defect which could cause a crash or could cause injury or death, you should immediately inform the National Highway Traffic Safety Administration (NHTSA) in addition to notifying American Honda Motor Co., Inc.

If NHTSA receives similar complaints, it may open an investigation, and if it finds that a safety defect exists in a group of vehicles, it may order a recall and remedy campaign. However, NHTSA cannot become involved in individual problems between you, your authorized Honda Fit EV dealer, or American Honda Motor Co., Inc.

To contact NHTSA, you may call the Vehicle Safety Hotline toll-free at 1-888-327-4236 (TTY: 1-800-424-9153); go to <http://www.safercar.gov>; or write to: Administrator, NHTSA, 1200 New Jersey Avenue, SE., Washington, DC 20590. You can also obtain other information about motor vehicle safety from <http://www.safercar.gov>.

## ■ U.S. Owners

Your new vehicle is covered by these warranties:

***New Vehicle Limited Warranty*** – covers your new vehicle, except for the emissions control systems and accessories, against defects in materials and workmanship.

***Seat Belt Limited Warranty*** – a seat belt that fails to function properly is covered by a limited warranty. Please read your warranty booklet for details.

***Rust Perforation Limited Warranty*** – all exterior body panels are covered for rust-through from the inside for the specified time period with no mileage limit.

***Replacement Parts Limited Warranty*** – covers all Honda replacement parts against defects in materials and workmanship.

***Replacement 12 Volt Battery Limited Warranty*** – provides prorated coverage for a replacement battery purchased from an authorized Honda Fit EV dealer.

Restrictions and exclusions apply to all these warranties. Please read the Honda warranty information booklet that came with your vehicle for precise information on warranty coverages. Your vehicle's original tires are covered by their manufacturer. Tire warranty information is in a separate booklet.

## ■ Service Express

For electronic copies of service publications, you can purchase a subscription to Service Express. Visit [www.techinfo.honda.com](http://www.techinfo.honda.com) for pricing and options.

## ■ For U.S. Owners:

Manuals can be purchased from Helm Incorporated. You can order a manual by phone at (800) 782-4356 (credit card orders only), or online at [www.helminc.com](http://www.helminc.com).

## ☒ Authorized Manuals

### **Service Manual:**

Covers maintenance and recommended procedures for repair to motor and chassis components. It is written for the journeyman technician, but it is simple enough for most mechanically inclined owners to understand.

### **Electrical Troubleshooting Manual:**

Complements the Service Manual by providing in-depth troubleshooting information for each electrical circuit in your vehicle.

### **Body Repair Manual:**

Describes the procedures involved in the replacement of damaged body parts.

Honda dealership personnel are trained professionals.

They should be able to answer all your questions. If you encounter a problem that your dealership does not solve to your satisfaction, please discuss it with the dealership's service manager or general manager. If you are dissatisfied with the decision made by the dealership's management, contact Honda Customer Services.

## **U.S. Owners:**

American Honda Motor Co., Inc.  
Honda Automobile Customer Service  
Mail Stop 500-2N-7A  
1919 Torrance Blvd.  
Torrance, CA 90501-2746  
Tel: (800) 999-1009

## Customer Service Information

When you call or write, please give us the following information:

- Vehicle Identification Number
  - **Vehicle Identification Number (VIN)**  
P. 255
- Date of purchase
- Odometer reading of your vehicle
- Your name, address, and telephone number
- A detailed description of the problem
- Name of the dealer who sold the vehicle to you

## Numbers

120V AC (AC Level 1) .....	173
240V AC (AC Level 2) .....	175
3-Mode Drive System .....	14, 155

## A

ABS (Anti-lock Brake System) .....	167
Accessory Power Socket .....	130
Acoustic Vehicle Alerting System .....	156
Active Head Restraints .....	124

### Additives

Coolant .....	197
Washer .....	201

### Adjusting

Armrest .....	125
Front Seats .....	120
Head Restraints .....	122
Headlights .....	202
Mirrors .....	119
Rear Seats .....	125
Steering Wheel .....	118

### Air Conditioning System (Climate Control System)

Changing the Mode .....	133
Defrosting the Windscreen and Windows .....	134
Dust and Pollen Filter .....	223
Recirculation/Fresh Air Mode .....	134
Sensors .....	135
Using Automatic Climate Control .....	133

Using the Interactive Remote .....	138
<b>Air Pressure</b> .....	212, 254
<b>Airbags</b> .....	41
Advanced Airbags .....	47
After a Collision .....	45
Airbag Care .....	55
Event Data Recorder .....	27
Front Airbags (SRS) .....	44
Indicator .....	52, 74, 76
Passenger Airbag Off Indicator .....	53
Sensors .....	41
Side Airbag Cutoff System .....	50
Side Airbag Off Indicator .....	54
Side Airbags .....	48
Side Curtain Airbags .....	51
<b>Anti-lock Brake System (ABS)</b> .....	167
Indicator .....	74
<b>Armrest</b> .....	125
<b>Audio System</b> .....	142
Remote Controls .....	3
<b>Authorized Manuals</b> .....	259
<b>Auto Door Locking/Unlocking</b> .....	104
<b>Auxiliary Input Jack</b> .....	5
<b>Average Fuel Economy</b> .....	86
<b>Average Fuel Economy Records</b> .....	86
<b>Average Speed</b> .....	85

## B

### Battery

Charging .....	171
----------------	-----

Charging System Indicator .....	242
Energy Economy .....	184
High Voltage .....	11, 181
High Voltage Battery Charge Level Gauge .....	82
Jump Starting .....	238
Low Charge Indicator .....	71
Maintenance (Replacing) .....	221, 222
Safety Checklist .....	171
<b>Belts (Seat)</b> .....	34
<b>Beverage Holders</b> .....	129
<b>Bluetooth® HandsFreeLink®</b> .....	3
<b>Booster Seats (For Children)</b> .....	67
<b>Brake System</b> .....	165
Anti-lock Brake System (ABS) .....	167
Brake Assist System .....	168
Fluid .....	200
Foot Brake .....	166
Indicator .....	70, 243
Parking Brake .....	165
<b>Brake Warning Indicator</b> .....	70, 243
<b>Brightness Control (Instrument Panel)</b> .....	116
<b>Bulb Replacement</b> .....	202
Back-Up Light .....	205
Brake/Taillight Bulbs .....	205
Front Turn Signal Light Bulbs .....	203
Headlights .....	202
High-Mount Brake Light .....	206
Parking/Side Marker Light Bulbs .....	204
Rear License Plate Light .....	206
Rear Turn Signal Light Bulbs .....	205

Bulb Specifications..... 254

## C

Cargo Floor Box ..... 130

Carrying Cargo..... 145, 147

Certification Label ..... 255

Changing Bulbs..... 202

Charge Connector..... 174

Charge Lid..... 174, 176

Unable to Open..... 252

Charge Lid Release Button..... 2, 173, 175

Charge Timer Setting ..... 182

Charging..... 171

120V AC (AC Level 1)..... 173

240V AC (AC Level 2)..... 175

Cannot Start Charging..... 178

Charge Connector..... 174

Charge Indicator (vehicle side)..... 180

Charge Lid..... 174, 176

Charging Cable ..... 173

Control Box ..... 177

High Voltage Battery..... 181

Timer..... 182

Using the Interactive Remote ..... 138

Charging System Indicator ..... 72, 242

Child Safety..... 56

Childproof Door Locks..... 103

Child Seat..... 56

Booster Seats..... 67

Child Seat for Infants..... 58

Child Seat for Small Children..... 59

Installing a Child Seat with a Lap/Shoulder

Seat Belt..... 63

Larger Children ..... 66

Rear-facing Child Seat..... 58

Selecting a Child Seat..... 60

Childproof Door Locks ..... 103

Cleaning the Exterior..... 225

Cleaning the Interior..... 224

Climate Control System..... 133

Changing the Mode..... 133

Defrosting the Windscreen and

Windows..... 134

Dust and Pollen Filter..... 223

Recirculation/Fresh Air Mode..... 134

Sensors ..... 135

Using Automatic Climate Control..... 133

Using the Interactive Remote..... 138

Coat Hook..... 131

Control Box..... 177

Controls..... 97

Coolant ..... 197

Adding to the Radiator..... 198

Adding to the Reserve Tank..... 197, 199

Coolant (Climate Control System)..... 199

Adding to the Reserve Tank..... 199

Coolant (Motor) ..... 197

Adding to the Radiator..... 198

Adding to the Reserve Tank..... 197

Creeping (Transmission)..... 152

Cruise Control ..... 157

Indicator ..... 78

Cup Holders..... 129

Customer Service Information ..... 260

Customized Features ..... 89

## D

Daytime Running Lights ..... 113

Dead Battery (12 volt) ..... 238

Devices that Emit Radio Waves..... 256

Dimming

Headlights ..... 112

Rearview Mirror ..... 119

Directional Signals (Turn Signal)..... 112

Door Mirrors..... 119

Doors ..... 98

Auto Door Locking..... 104

Auto Door Unlocking ..... 104

Door and Tailgate Open Indicator ..... 33, 75

Keys..... 98

Locking/Unlocking the Doors from the

Inside..... 102

Locking/Unlocking the Doors from the

Outside..... 100

Lockout Prevention System ..... 101

DOT Tire Quality Grading..... 214

Driving ..... 143

Braking..... 165

Cruise Control ..... 157

Shifting..... 153

Transmission .....	152
Turning on the Power .....	150
Dust and Pollen Filter .....	223

## E

Eco Assist System .....	12
Eco Drive Bar .....	13, 88
Eco Score .....	13, 87
ECON Mode Indicator .....	78, 155
Elapsed Time .....	85
Electric Power Steering (EPS) System	
Indicator .....	75, 243
Electric Vehicle .....	8
How the Electric Vehicle Works .....	10
Electricity Consumption Indicators .....	82
Electronic Stability Control (ESC) .....	160
Emergency .....	250
EPS (Electric Power Steering)	
System .....	75, 243
Exterior Care (Cleaning) .....	225
Exterior Mirrors .....	119

## F

Features .....	141
Filters	
Dust and Pollen .....	223
Flat Tire .....	229
Floor Mats .....	224

## Fluids

Brake .....	200
Climate Control Coolant .....	199
Coolant .....	197
Windshield Washer .....	201
Folding Down the Rear Seats .....	125
Foot Brake .....	166
Front Airbags (SRS) .....	44
Front Seats .....	120
Adjusting .....	120
Fuses .....	245
Inspecting and Changing .....	249
Locations .....	245

## G

Gauges .....	81, 98
kmh/mph Change Button .....	81
Glass (care) .....	226
Glove Box .....	128

## H

Halogen Bulbs .....	202
Handling the Unexpected .....	227
HandsFreeLink® (HFL) .....	3
Hazard Warning Button .....	2
Head Restraints .....	122
Headlights .....	112
Aiming .....	202
Dimming .....	112, 113

Operating .....	112
Heaters (Seat) .....	132
HFL (HandsFreeLink®) .....	3
High Beam Indicator .....	77
High Voltage Battery .....	11, 181
Charge Level Gauge .....	82
Charging .....	171
Energy Economy .....	184
Low Charge Indicator .....	71
High Voltage Battery Charge Level	
Gauge .....	82

## I

Identification Numbers .....	255
Motor and Transmission .....	255
Vehicle Identification .....	255
Illumination Control .....	116
Knob .....	116
Immobilizer System .....	107
Indicator .....	77
Indicators .....	70
ABS (Anti-lock Brake System) .....	74
Brake System .....	70
Brake Warning .....	70, 243
Charge Connector .....	71
Charging System .....	72, 242
CRUISE CONTROL .....	78, 158
CRUISE MAIN .....	78, 157
Door and Tailgate Open .....	33, 75
ECON Mode .....	78, 155



EPS (Electric Power Steering) System ..	75, 243		
High Beam.....	77		
Immobilizer System.....	77		
Lights On.....	77		
Low Charge.....	71		
Low Tire Pressure/TPMS .....	75, 162		
NORMAL Mode.....	78, 155		
POWER REDUCED.....	72		
POWER SYSTEM .....	71		
Seat Belt Reminder .....	35, 73		
Security System Alarm .....	77		
Shift Position .....	73		
Side Airbag Off.....	54, 76		
SPORT Mode .....	78, 155		
Supplemental Restraint System .....	52, 74		
System Message .....	76		
Turn Signal .....	76		
VSA® (Vehicle Stability Assist) System.....	74, 160		
VSA® OFF .....	74, 161		
<b>Information</b> .....	253		
<b>Instrument Panel</b> .....	69		
Brightness Control .....	116		
<b>Interactive Remote</b> .....	136		
Error Code.....	139		
<b>Interior Lights</b> .....	126		
<b>Interior Rearview Mirror</b> .....	119		
<b>J</b>			
<b>Jump Starting</b> .....	238		
<b>K</b>			
<b>Keyless Lockout Prevention</b> .....	101		
<b>Keys</b>			
Lockout Prevention.....	101		
Rear Door Won't Open.....	103		
Remote Transmitter.....	100		
Types and Functions .....	98		
Won't Turn .....	25		
<b>L</b>			
<b>LATCH (Child Seats)</b> .....	61		
<b>Lights</b> .....	112, 202		
Bulb Replacement .....	202		
Daytime Running Lights.....	113		
High Beam Indicator.....	77		
Interior.....	126		
Light Switches .....	112		
Lights On Indicator.....	77		
Turn Signals .....	112		
<b>Load Limits</b> .....	147		
<b>Locking/Unlocking</b> .....	98		
Auto Door Locking/Unlocking.....	104		
Childproof Door Locks.....	103		
From Inside .....	102		
From Outside .....	100		
Keys .....	98		
Lockout Prevention System.....	101		
Using a Key .....	101		
<b>Lockout Prevention System</b> .....	101		
<b>Low Battery Charge (12 volt)</b> .....	242		
<b>Low Charge Indicator</b> .....	71		
<b>Lower Anchors</b> .....	61		
<b>Lubricant Specifications Chart</b> .....	254		
<b>Luggage (Maximum Load Limit)</b> .....	147		
<b>M</b>			
<b>Maintenance</b> .....	187		
Battery (12 volt) .....	220		
Brake Fluid .....	200		
Cleaning .....	224		
Climate Control System .....	223		
Coolant (Climate Control System) .....	199		
Coolant (Motor).....	197		
Interactive Remote .....	222		
Minder™ .....	191		
Precautions .....	188		
Radiator .....	198		
Remote Transmitter .....	221		
Replacing Light Bulbs .....	202		
Schedule.....	193		
Tires.....	211		
Under the Hood .....	195		
<b>Maintenance Minder™</b> .....	191		
<b>Maintenance Schedule</b> .....	193		
<b>Map Lights</b> .....	126		
<b>Maximum Load Limit</b> .....	147		
<b>Meters, Gauges</b> .....	81		
<b>Mirrors</b> .....	119		
Adjusting .....	119		
Door .....	119		

Exterior .....	119
Interior Rearview .....	119
<b>Modifications</b> .....	185
<b>Motor</b> .....	255
Jump Starting .....	238
Starting .....	150
Switch Buzzer .....	111
<b>Multi-Information Display</b> .....	83
 <b>N</b>	
<b>NORMAL Mode Indicator</b> .....	78, 155
<b>Numbers (Identification)</b> .....	255
 <b>O</b>	
<b>Odometer</b> .....	84
<b>Opening/Closing</b>	
Hood .....	196
Power Windows .....	109
Tailgate .....	105
<b>Outside Temperature</b> .....	85
<b>Overheating</b> .....	241
 <b>P</b>	
<b>Panic Mode</b> .....	108
<b>Parking</b> .....	169
<b>Parking Brake</b> .....	165
<b>Passenger Airbag Off Indicator</b> .....	53
<b>Passing Indicators</b> .....	112
<b>POWER REDUCED Indicator</b> .....	72

<b>Power Switch</b> .....	111
<b>Power System</b> .....	10, 111, 150
Overheating .....	241
<b>POWER SYSTEM Indicator</b> .....	71
<b>POWER/CHARGE Gauge</b> .....	81
<b>Precautions While Driving</b> .....	152
Rain .....	152
<b>Pregnant Women</b> .....	39
<b>Puncture (Tire)</b> .....	229

## R

<b>Radiator</b> .....	198
<b>Range Display</b> .....	16, 82
<b>Rear Defogger Button</b> .....	117
<b>Rear Seats (Folding Down)</b> .....	125
<b>Rearview Camera</b> .....	7
<b>Rearview Mirror</b> .....	119
<b>Regulations</b> .....	163, 179, 214, 256
<b>Remote Transmitter</b> .....	100
<b>Replacement</b>	
Battery .....	221, 222
Bulbs .....	202
Fuses .....	245, 246, 247
Tires .....	217
Wiper Blade Rubber .....	207, 209
<b>Reporting Safety Defects</b> .....	257
<b>Resetting a Trip Meter</b> .....	84

## S

<b>Safe Driving</b> .....	29
<b>Safety Check</b> .....	33
<b>Safety Labels</b> .....	68
<b>Safety Message</b> .....	28
<b>Seat Belts</b> .....	34
Adjusting the Shoulder Anchor .....	38
Automatic Seat Belt Tensioners .....	36
Checking .....	40
Fastening .....	37
Installing a Child Seat with a Lap/Shoulder Seat Belt .....	63
Pregnant Women .....	39
Reminder .....	35
Warning Indicator .....	35, 73
<b>Seat Heaters</b> .....	132
<b>Seats</b> .....	120
Adjusting .....	120
Front Seats .....	120
Rear Seats .....	125
Seat Heaters .....	132
<b>Security System</b> .....	107
Immobilizer System Indicator .....	77
Security System Alarm Indicator .....	77
<b>SEL/RESET Button</b> .....	83, 89
<b>Select Lever</b> .....	21
Operation .....	21, 153, 154
Releasing .....	240
Won't Move .....	240
<b>Selecting a Child Seat</b> .....	60
<b>Shift Lever</b> .....	21, 153

Shift Lever Position Indicator .....	73, 154
Shift Lever Positions	
Transmission .....	153
Shifting (Transmission) .....	153
Shoulder Anchor .....	38
Side Airbags .....	48
Cutoff System .....	50
Off Indicator .....	50
Side Curtain Airbags .....	51
Smartphone App .....	20
Snow Tires .....	219
Specifications .....	254
Speedometer .....	81
SPORT Mode Indicator .....	78, 155
SRS Airbags (Airbags) .....	44
Steering Wheel .....	118
Adjusting .....	118
Stopping .....	169
Summer Tires .....	219
Supplemental Restraint System (SRS) .....	44
Switches (Around the Steering Wheel) .....	2, 3, 111
System Message Indicator .....	76

## T

Tailgate .....	105
Unable to Open .....	251
Telematics Control Unit .....	95
Smartphone App .....	20
Timer .....	182

Tire Pressure Monitoring System (TPMS) .....	162
Indicator .....	75
Tire Repair Kit .....	229
Tires .....	211
Air Pressure .....	212, 254
Checking and Maintaining .....	211
Inspection .....	211
Labeling .....	212
Puncture (Flat Tire) .....	229
Regulations .....	214
Rotation .....	218
Summer .....	219
Tire Chains .....	219
Tire Repair Kit .....	229
Wear Indicators .....	216
Winter .....	219
Tools .....	228
Towing Your Vehicle	
Emergency .....	250
TPMS (Tire Pressure Monitoring System) .....	162
Indicator .....	75
Transmission .....	152, 153
Creeping .....	152
Number .....	255
Operating the Shift Lever .....	21, 154
Shift Lever Does Not Move .....	240
Shift Lever Position Indicator .....	73, 154
Shifting .....	153
Trip Meter .....	84

Trip Summary .....	95
Troubleshooting .....	227
Blown Fuse .....	245, 246, 247
Brake Pedal Vibrates .....	25
Buzzer Sounds When Opening Door .....	26
Cannot Open the Tailgate .....	251
Cannot Start Charging .....	178
Emergency Towing .....	250
Error Code (Interactive Remote) .....	139
Motor Won't Start .....	237
Noise When Braking .....	26
Overheating .....	241
Puncture/Flat Tire .....	229
Rear Door Won't Open .....	25, 103
Select Lever Won't Move .....	240
Unable to Open the Charge Lid .....	252
Warning Indicators .....	70
Turn Signals .....	112
Indicators (Instrument Panel) .....	76
Turning on the Power .....	150
Does Not Start .....	237
Jump Starting .....	238
Power Switch Buzzer .....	111

## U

Unlocking the Doors .....	100, 102
USB Adapter Cable .....	5

## V

Vanity Mirrors .....	5
Vehicle Identification Number (VIN) .....	255
Vehicle Stability Assist (VSA®) .....	160
Off Button .....	161
Off Indicator .....	74
System Indicator .....	74
VSA® (Vehicle Stability Assist) .....	160

## W

Warning and Information Messages .....	79
Warning Indicator On/Blinking .....	242
Warning Labels .....	68
Warranties (Warranty Manual provided separately) .....	258
Watts .....	254
Wear Indicators (Tire) .....	216
Wheel Nut Wrench .....	228
Window Washers .....	114
Adding/Refilling Fluid .....	201
Switch .....	114
Windshield .....	114
Cleaning .....	226
Washer Fluid .....	201
Wiper Blades .....	207
Wipers and Washers .....	114
Winter Tires .....	219
Snow Tires .....	219
Tire Chains .....	219

Wipers and Washers .....	114
Checking and Replacing Wiper Blades .....	207, 209
Worn Tires .....	211

