

Adding Oil

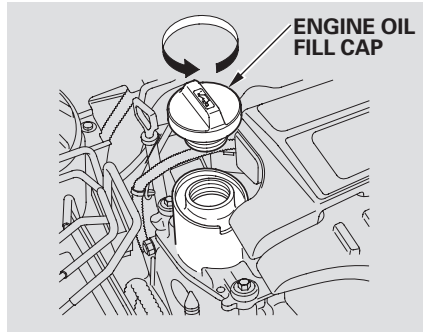

To add oil, unscrew and remove the engine oil fill cap on top of the valve cover. Pour in the oil, and install the engine oil fill cap. Tighten it securely. Wait a few minutes and recheck the oil level. Do not fill above the upper mark; you could damage the engine.

Pour the oil slowly and carefully so you do not spill. Clean up any spills immediately. Spilled oil could damage components in the engine

compartment.

Recommended Oil

Oil is a major contributor to your engine's performance and longevity. Always use a premium-grade 0W-20 detergent oil displaying the API Certification Seal. This seal indicates the oil is energy conserving, and that it meets the American Petroleum Institute's latest requirements.

Honda Motor Oil is the preferred 0W-20 lubricant for your vehicle. It is highly recommended that you use Honda Motor Oil in your vehicle for optimum engine protection.

Make sure the API Certification Seal says "For Gasoline Engines."



CONTINUED

Engine Oil

The oil's viscosity or weight is provided on the container's label. Select the oil for your vehicle according to this chart.

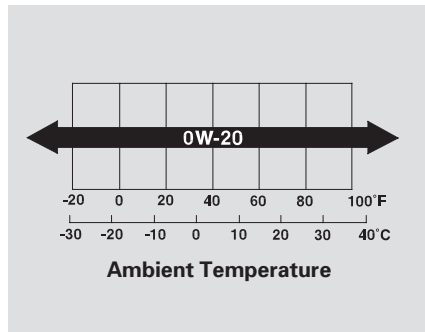

A very low-viscosity, fuel-efficient 0W-20 oil is the preferred engine lubricant for your Civic Hybrid. This special oil is formulated to help your engine use less fuel. It is available at your Honda dealer. A 5W-20 oil may be used if 0W-20 is not available.

Synthetic Oil

You may use a synthetic motor oil if it meets the same requirements given for a conventional motor oil: it displays the API Certification Seal, and it is the proper weight as shown on the chart. When using synthetic oil, you must follow the oil and filter change intervals given in the maintenance schedule.

Additives

Your Honda does not require any oil additives. Additives may adversely affect your engine's or transmission's performance and durability.

Changing the Oil and Filter

Always change the oil and filter according to the time and distance (miles/kilometers) recommendations in the maintenance schedule. The oil and filter collect contaminants that can damage your engine if they are not removed regularly.

Changing the oil and filter requires special tools and access from underneath the car. The car should be raised on a service station-type hydraulic lift for this service. Unless you have the knowledge and proper equipment, you should have this maintenance done by a skilled mechanic.

1. Run the engine until it reaches normal operating temperature, then shut it off.
2. Open the hood and remove the engine oil fill cap.

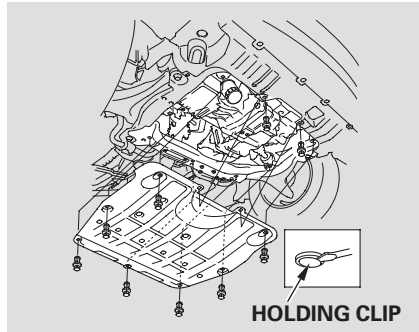

3. Remove the nine holding clips with a flat-tipped screwdriver, then pull the cover down.

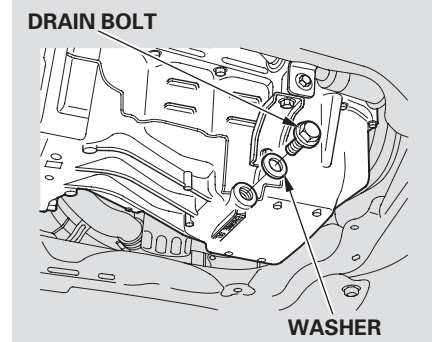

4. Remove the oil drain bolt and washer from the bottom of the engine. Drain the oil into an appropriate container.

CONTINUED

Engine Oil

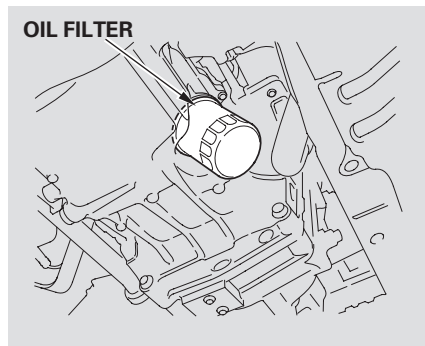

5. Remove the oil filter and let the remaining oil drain. A special wrench (available from your Honda dealer) is required to remove the filter.
6. Install a new oil filter according to instructions that come with it.
7. Put a new washer on the drain bolt, then reinstall the drain bolt. Tighten it to:

29 lbf-ft (39 N·m , 4.0 kgf·m)
8. Refill the engine with the recommended oil.
Engine oil change capacity (including filter):

3.4 US qt (3.2 ℓ , 2.8 Imp qt)
9. Replace the engine oil fill cap. Start the engine. The oil pressure indicator light should go out within five seconds. If it does not, turn off the engine and reinspect your work.
10. Let the engine run for several minutes and check the drain bolt and oil filter for leaks.

11. Turn off the engine, let it sit for several minutes, then check the oil level. If necessary, add oil to bring the level to the upper mark on the dipstick.
12. Put the under cover back in place and reinstall the nine holding clips. Lock the clips securely by pushing on the center of each clip.

NOTICE

Improper disposal of engine oil can be harmful to the environment. If you change your own oil, please dispose of the used oil properly. Put it in a sealed container and take it to a recycling center. Do not discard it in a trash bin or dump it on the ground.