

Your Civic GX is designed to operate on Compressed Natural Gas (CNG). The natural gas you use to refuel must meet NFPA-52 and SAE J1616 standards for fuel composition and quality.

If you use a fuel that does not meet these standards, you may feel a decrease in engine power and your vehicle's emissions controls may be damaged.

Compressed Natural Gas (CNG)

The main component of compressed natural gas is methane, a highly flammable, colorless gas. While it is the same gas that is burned in everyday home appliances such as kitchen stoves and water heaters, the CNG in your vehicle is stored under high pressure (maximum 3,600 psi/24,800 kPa).

The CNG fuel system in your Civic, including the tank and hose, has been designed to hold gas at this pressure. It has also been tested for safety. You should never smell gas or hear a hissing sound unless you are refueling. If you smell gas or hear a hissing sound at any other time, you need to shut down the fuel system. Follow the instructions on page 13.

⚠ WARNING

Compressed natural gas is flammable and highly explosive. You could be killed or seriously injured if leaking natural gas is ignited.

If you suspect a leak, have your vehicle immediately inspected and repaired by an authorized Honda Civic GX dealer.

Fuel, Refueling Procedure

CNG Identification

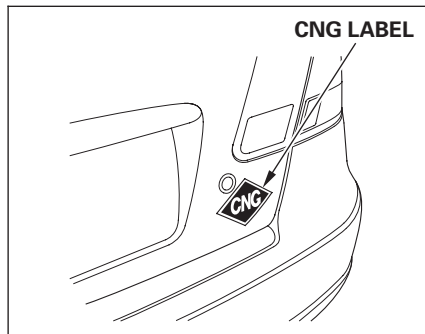

Your vehicle has an identifying “CNG” label attached next to the rear license plate. Do not remove this label. This label is necessary for insuring your vehicle. Driving without this label may violate the laws or regulations in some states.

Refueling Procedure

There are two methods of refueling, fast filling or slow filling.

Fast filling is normally used in fuel stations for natural gas vehicles. It takes about three to five minutes to fill up the fuel tank.

Slow filling is done with a vehicle refueling appliance. Refueling takes approximately 1 hour per gallon.

Always observe all safety recommendations and operating instructions on the refueling equipment.

When refueling, you should use a fuel fill nozzle that complies with ANSI/AGA NGV-1-1994 standards. Nozzles are designed according to their maximum fill pressure: P24 for 2,400 psi (pounds per square inch), P30 for 3,000 psi, and P36 for 3,600 psi.

Your Civic’s maximum fill pressure is 3,600 psi (24,800 kPa), so you should refuel with a P36 nozzle. Using a P30 nozzle will fill the tank to the second (3,000 psi) fill mark on the fuel gauge. Using a P24 nozzle will not fill the tank completely.

During a fast fill, the natural gas will be warmed by the refueling process, causing it to expand and reduce the amount of fuel you can put in.

Filling the Fuel Tank

The refueling procedure can vary with the refueling station. The following explains the typical refueling procedure with fast fill equipment. With slow fill equipment, or other types of refueling equipment, follow the instructions on the equipment.

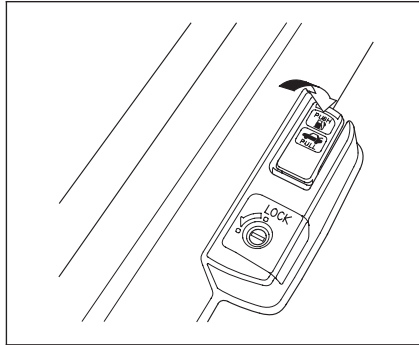

1. Because the fuel receptacle is on the driver's side of the vehicle, park with that side closest to the refueling station.
2. Turn the ignition switch to LOCK (0) and apply the parking brake.
3. Open the fuel receptacle door by pushing on the handle to the left of the driver's seat.

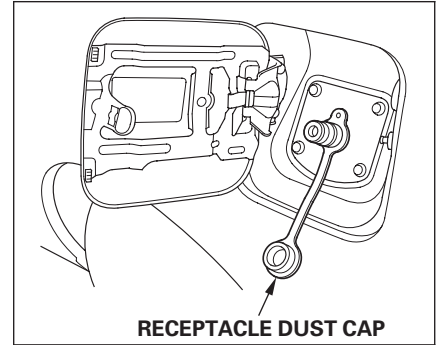

4. Remove the receptacle dust cap from the fuel receptacle. Clean up any dirt and debris around the fuel receptacle.

CONTINUED

Refueling Procedure

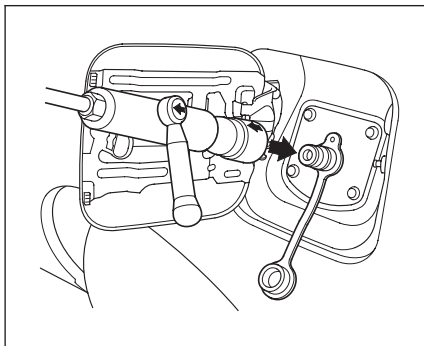

5. Securely connect the CNG fill nozzle to the fuel receptacle by turning the lever until the arrows on the nozzle point to each other.

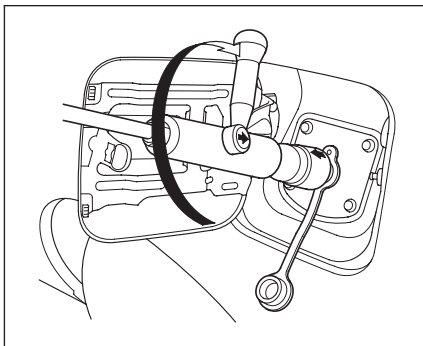

6. Follow the instructions on the refueling station to begin refueling.

While refueling, you may hear a chattering sound. This is normal.

If you hear or see fuel/vapor leaking from the nozzle-receptacle connection, stop refueling immediately. Dirt or other debris may be preventing a positive connection. Turn off the refueling station, remove the nozzle, reconnect it to the receptacle, and begin refueling again. If it continues to leak, have an authorized Honda Civic GX dealer inspect the sealing O-ring in the receptacle. It may be missing, damaged, or worn.

7. Refueling will stop automatically when the tank is full. Follow the instructions on the refueling station to turn it off.
8. Disconnect the CNG fill nozzle from the fuel receptacle by slowly turning the lever on the nozzle 180 degrees. You may hear a brief hissing sound as a small amount of gas escapes. This is normal.

9. Put the receptacle dust cap on the fuel receptacle securely.
10. Push the fuel receptacle door closed until it latches.

If you are not sure how to operate the refueling station, ask for assistance.

Refueling Station Information

To obtain information about the locations of Compressed Natural Gas (CNG) refueling stations, contact the Natural Gas Vehicle Coalition (NGVC) at (202) 824-7360, extension 1. Online, use www.afdc.doe.gov for the 49 states, or www.cngvc.org for California.

Fuel System Components

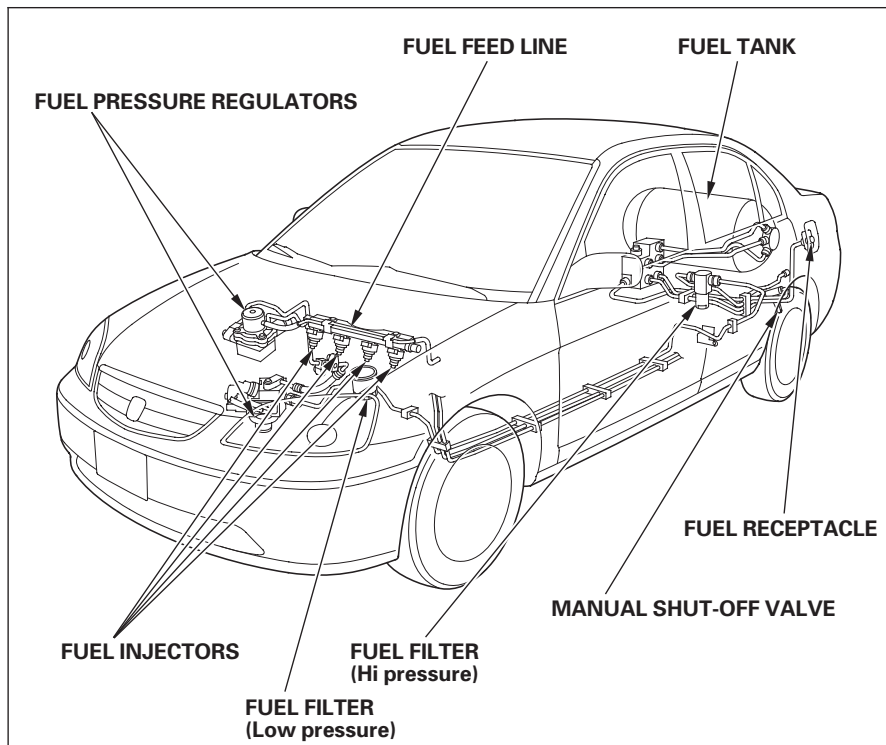

Fuel system components include a fuel tank located in the trunk, an integrated fuel pressure regulator, an in-tank fuel shut-off valve, fuel high pressure lines, electronically controlled multipoint fuel injectors and other equipment.

Fuel system components in the Civic CNG comply with NFPA-52 standards.

Your vehicle is equipped with genuine Honda component parts that have been designed and approved for use in a compressed natural gas vehicle. Never modify or replace any original components or parts with those specified for a gasoline-powered vehicle.

Improper parts or components can damage your vehicle's fuel system and affect your vehicle's safety and performance.

Fuel System Components, Fuel Cutoff System

Fuel system maintenance and repair should be done only by an authorized Honda Civic GX dealer.

⚠ WARNING

Tampering with, or improperly maintaining the high-pressure fuel system can cause a dangerous condition in which you can be seriously hurt or killed.

Never attempt to modify the fuel system, and always have maintenance performed by an authorized Honda Civic GX dealer.

Fuel Cutoff System

The in-tank fuel shut-off valve is controlled by the ignition switch. When the ignition switch is in the LOCK (0) or ACCESSORY (I) position, the valve is closed, shutting off fuel flow to the engine. It opens when the ignition switch is turned to ON (II). This is similar to how an electric fuel pump works in a gasoline-powered vehicle.

Manual Shut-off Valve

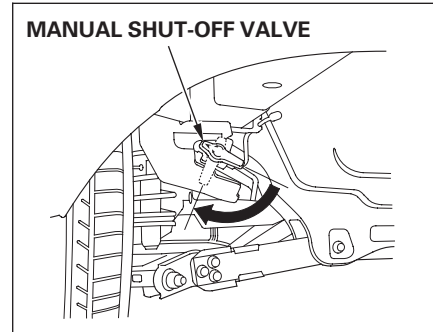

A manual shut-off valve is located underneath the vehicle, near the rear tire on the driver's side. We recommend that you locate this valve so you can find it quickly.

CONTINUED

Fuel Cutoff System, Carrying Cargo

To turn off the valve, turn the lever one-quarter turn clockwise. Turn it counterclockwise to turn the valve back on.

Turn off the valve if you ever suspect a fuel leak or are involved in an accident.

Carrying Cargo

The maximum load you can carry in your vehicle is 700 lbs (317 kg). That figure includes the total weight of four occupants (driver and three passengers), their cargo, and any accessories. The maximum recommended weight for cargo in the trunk is 100 lbs (45 kg).

The fuel tank is located in the trunk, with a partition between the fuel tank and the cargo space.

When you store small items in the trunk, secure them so they will not shift while you are driving. Loose items can fly over the partition and damage the fuel tank and fuel system components.

Do not carry large, heavy or pointed objects in the trunk. They may damage the fuel tank.