

Symbol	Maintenance Main Items
A	<ul style="list-style-type: none"> <li>● Replace engine oil<sup>1</sup></li> </ul>
B	<ul style="list-style-type: none"> <li>● Replace engine oil<sup>1</sup> and oil filter</li> <li>● Inspect front and rear brakes</li> <li>● Check parking brake adjustment</li> <li>● Inspect these items:               <ul style="list-style-type: none"> <li>● Tie rod ends, steering gear box, and boots</li> <li>● Suspension components</li> <li>● Driveshaft boots</li> <li>● Brake hoses and lines (including ABS)</li> <li>● All fluid levels and condition of fluids</li> <li>● Exhaust system<sup>#</sup></li> <li>● Fuel lines and connections<sup>#</sup></li> </ul> </li> </ul>

1: If the message "SERVICE" does not appear more than 12 months after the display is reset, change the engine oil every year.

# : See information on maintenance and emissions warranty on page 185.

NOTE: ● Independent of the maintenance minder display, replace the brake fluid every 3 years.  
 ● Inspect idle speed every 160,000 miles (256,000 km).  
 ● Adjust the valves during services A, B, 1, 2, or 3 only if they are noisy.

Symbol	Maintenance Sub Items
1	<ul style="list-style-type: none"> <li>● Rotate tires</li> </ul>
2	<ul style="list-style-type: none"> <li>● Replace air cleaner element If you drive in dusty conditions, replace every 15,000 miles (24,000 km).</li> <li>● Replace dust and pollen filter If you drive primarily in urban areas that have high concentrations of soot in the air from industry and from diesel-powered vehicles, replace every 15,000 miles (24,000 km).</li> <li>● Inspect drive belt</li> </ul>
3	<ul style="list-style-type: none"> <li>● Replace transmission fluid</li> </ul>
4	<ul style="list-style-type: none"> <li>● Replace spark plugs</li> <li>● Inspect valve clearance</li> </ul>
5	<ul style="list-style-type: none"> <li>● Replace engine coolant</li> </ul>

# Maintenance Record

You or the servicing dealer can record all completed maintenance here. When maintenance is performed, record the mileage, circle the coded item(s) completed, and write in any other non-coded items (such as brake fluid replacement) below the codes. Keep the receipts for all work done on your vehicle. Maintenance can also be recorded in your Honda service history booklet.

Mileage	Maintenance Performed							Signature
								Date
mi km	A	B	1	2	3	4	5	
mi km	A	B	1	2	3	4	5	
mi km	A	B	1	2	3	4	5	
mi km	A	B	1	2	3	4	5	
mi km	A	B	1	2	3	4	5	
mi km	A	B	1	2	3	4	5	
mi km	A	B	1	2	3	4	5	
mi km	A	B	1	2	3	4	5	

Mileage	Maintenance Performed							Signature
								Date
mi km	A	B	1	2	3	4	5	
mi km	A	B	1	2	3	4	5	
mi km	A	B	1	2	3	4	5	
mi km	A	B	1	2	3	4	5	
mi km	A	B	1	2	3	4	5	
mi km	A	B	1	2	3	4	5	
mi km	A	B	1	2	3	4	5	
mi km	A	B	1	2	3	4	5	

# Maintenance Record

Mileage	Maintenance Performed							Signature
								Date
mi km	A	B	1	2	3	4	5	
mi km	A	B	1	2	3	4	5	
mi km	A	B	1	2	3	4	5	
mi km	A	B	1	2	3	4	5	
mi km	A	B	1	2	3	4	5	
mi km	A	B	1	2	3	4	5	
mi km	A	B	1	2	3	4	5	

Mileage	Maintenance Performed							Signature
								Date
mi km	A	B	1	2	3	4	5	
mi km	A	B	1	2	3	4	5	
mi km	A	B	1	2	3	4	5	
mi km	A	B	1	2	3	4	5	
mi km	A	B	1	2	3	4	5	
mi km	A	B	1	2	3	4	5	
mi km	A	B	1	2	3	4	5	

Maintenance

## Fluid Locations

---

Except U.S. Si model

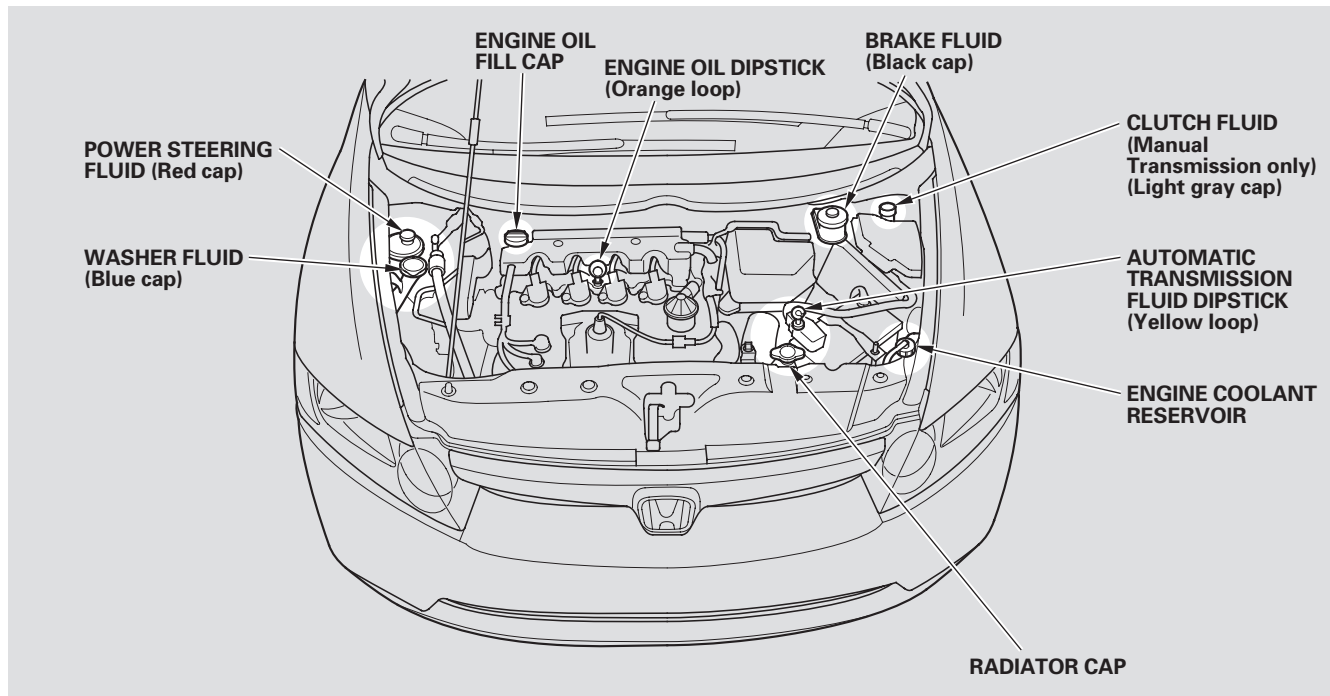

## U.S. Si model

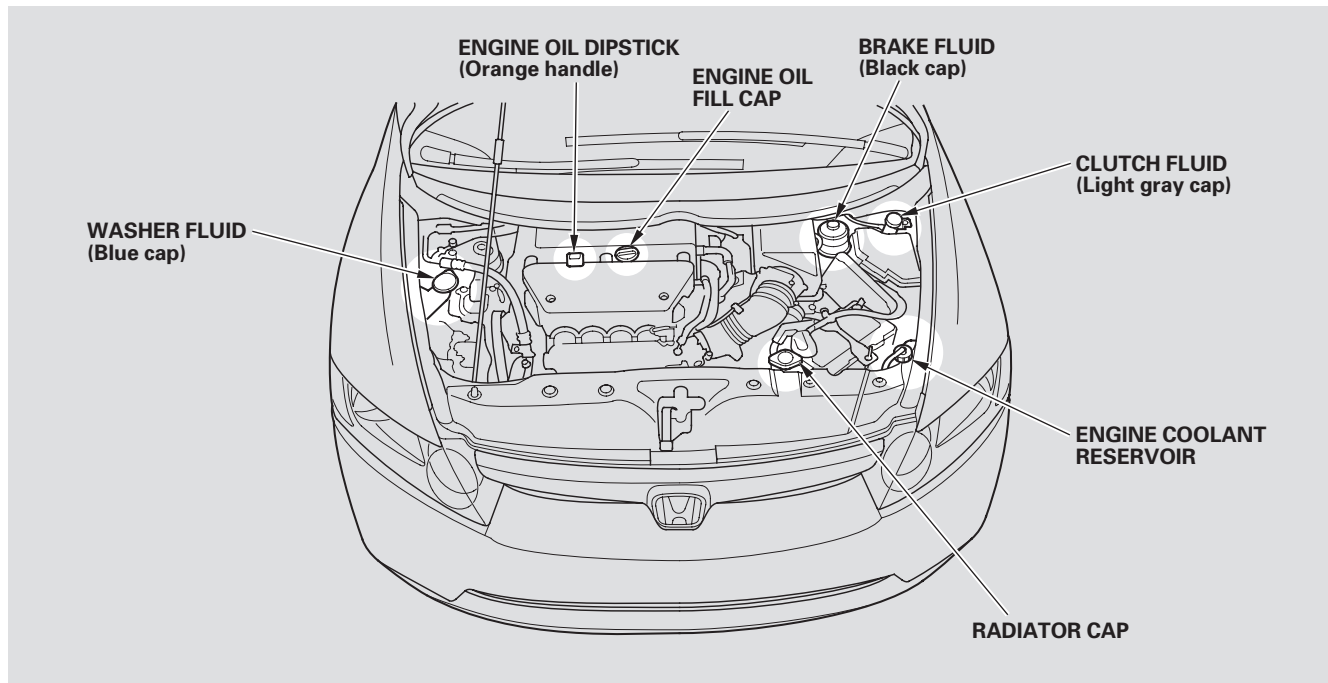

## Adding Engine Oil

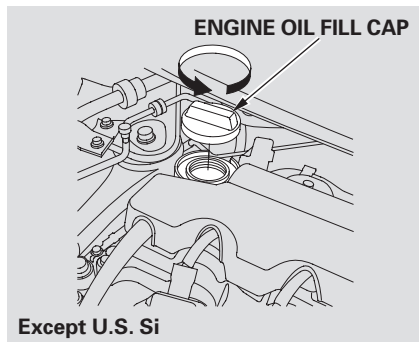

Unscrew and remove the engine oil fill cap on the valve cover. Pour in the oil slowly and carefully so you do not spill any. Clean up any spills immediately. Spilled oil could damage components in the engine compartment.

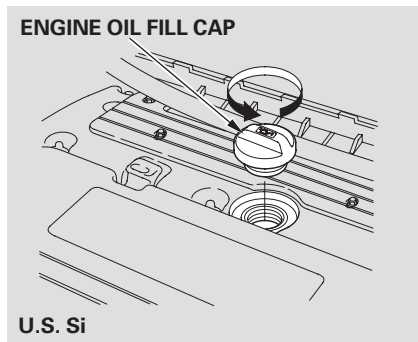

Reinstall the engine oil fill cap, and tighten it securely. Wait a few minutes, and recheck the oil level on the engine oil dipstick. Do not fill above the upper mark; you could damage the engine.

**Recommended Engine Oil**  
Oil is a major contributor to your engine's performance and longevity. Always use a premium-grade detergent oil displaying the API Certification Seal. This seal indicates the oil is energy conserving, and that it meets the American Petroleum Institute's latest requirements. It is highly recommended that you use Honda Motor Oil in your vehicle for optimum engine protection.

API CERTIFICATION SEAL

