

HONDALINK®

HONDA
The Power of Dreams

BLUETOOTH®
HANDSFREELINK®

AUDIO AND
CONNECTIVITY

VEHICLE
CONTROLS

INSTRUMENT PANEL

SAFETY
INFORMATION

VISUAL INDEX

TABLE OF CONTENTS

Accord

2017 Accord Sedan
OWNER'S GUIDE

INDEX

VOICE COMMAND
INDEX

CUSTOMER
INFORMATION

SPECIFICATIONS

MAINTENANCE

HANDLING THE
UNEXPECTED

DRIVING

NAVIGATION

DISCLOSURES

■ Devices That Emit Radio Waves

The following products and systems on your vehicle emit radio waves when in operation:

- Audio system
- *Bluetooth* Audio
- *Bluetooth* HandsFreeLink
- HomeLink Universal Transceiver
- Collision Mitigation Braking System
- Immobilizer system
- Remote transmitter
- Smart entry system*
- Wireless charger*

Each of the above complies with the appropriate requirements or the required standards of the FCC (Federal Communications Commission) and Industry Canada, described below:

As required by the FCC:

This device complies with Part 15 of the FCC rules. Operation is subject to the following two conditions: (1) This device may not cause harmful interference, and (2) this device must accept any interference received, including interference that may cause undesired operation.

Changes or modifications not expressly approved by the party responsible for compliance could void the user's authority to operate the equipment.

As required by Industry Canada:

This device complies with Industry Canada licence-exempt RSS standard(s). Operation is subject to the following two conditions: (1) this device may not cause interference, and (2) this device must accept any interference, including interference that may cause undesired operation of the device.

■ California Perchlorate Contamination Prevention Act

The airbags, seat belt tensioners, and CR-type batteries in this vehicle may contain perchlorate materials—special handling may apply. See www.dtsc.ca.gov/hazardouswaste/perchlorate/ for more information.

■ California Proposition 65 Warning

WARNING: This product contains or emits chemicals known to the state of California to cause cancer and birth defects or other reproductive harm.

■ Event Data Recorders

This vehicle is equipped with an event data recorder (EDR). The main purpose of an EDR is to record, in certain crash or near crash-like situations, such as an air bag deployment or hitting a road obstacle, data that will assist in understanding how a vehicle's systems performed. **The EDR is designed to record data related to vehicle dynamics and safety systems for a short period of time, typically 30 seconds or less. The EDR in this vehicle is designed to record such data as:**

- **How various systems in your vehicle were operating;**
- **Whether or not the driver and passenger safety belts were buckled/fastened;**
- **How far (if at all) the driver was depressing the accelerator and/or brake pedal; and,**
- **How fast the vehicle was traveling.**

These data can help provide a better understanding of the circumstances in which crashes and injuries occur. NOTE: EDR data are recorded by your vehicle only if a non-trivial crash situation occurs; no data are recorded by the EDR under normal driving conditions and no personal data (e.g., name, gender, age, and crash location) are recorded. However, other parties, such as law enforcement, could combine the EDR data with the type of personally identifying data routinely acquired during a crash investigation.

To read data recorded by an EDR, special equipment is required, and access to the vehicle or the EDR is needed. In addition to the vehicle manufacturer, other parties such as law enforcement that have the special equipment can read the information if they have access to the vehicle or the EDR.

The data belong to the vehicle owner and may not be accessed by anyone else except as legally required or with the permission of the vehicle owner.

■ Service Diagnostic Recorders

This vehicle is equipped with service-related devices that record information about powertrain performance. The data can be used to verify emissions law requirements and/or help technicians diagnose and solve service problems. It may also be combined with data from other sources for research purposes, but it remains confidential.

*if equipped

NAVIGATION

DRIVING

HANDLING THE UNEXPECTED

MAINTENANCE

SPECIFICATIONS

CUSTOMER INFORMATION

VOICE COMMAND INDEX

INDEX

TABLE OF CONTENTS

VISUAL INDEX

SAFETY INFORMATION

INSTRUMENT PANEL

VEHICLE CONTROLS

AUDIO AND CONNECTIVITY

BLUETOOTH® HANDSFREELINK®

HONDA LINK®

INTRODUCTION

This Owner's Guide is intended to help you quickly get acquainted with your **2017 Honda Accord Sedan**. It provides basic information and instructions on technology and convenience features, as well as emergency procedures and how to get assistance.

This guide is for vehicles sold in the United States and Canada. It covers all Accord Sedan models, so you may find descriptions of features and equipment that are not in your vehicle. Images throughout this guide are from U.S. vehicles and represent features and equipment that are available on some, but not all, models.

This guide is not intended to be a substitute for the Owner's Manual. The Owner Information CD enclosed in your glove box kit includes the Owner's Manual, Navigation Manual, and vehicle and tire warranties in electronic format. This information can be viewed on a computer (PC or Mac platform) and saved or printed for your reference. You can also visit owners.honda.com (U.S.) or myhonda.ca (Canada) to view the complete and most current information.

If you are the first registered owner of your vehicle, you may request a complimentary printed copy of the Owner's Manual, Navigation Manual, or Vehicle Warranty within the first six months of vehicle purchase. To request a copy, visit owners.honda.com (U.S.) and create or log in to your account. In Canada, please request a copy from your Honda dealer.

American Honda Motor Company strives to be proactive in protecting our environment and natural resources. By using electronic delivery for a considerable portion of the information typically found in a vehicle owner's manual, we are further reducing our impact on the environment.

Honda Automobile Customer Service

Your authorized Honda dealer should be able to answer any questions you have about your vehicle. However, if you are dissatisfied with the information you receive, you can call Honda Automobile Customer Service (see page 152).

Call (800) 999-1009 (U.S.) or (888) 946-6329 (Canada)

Honda Roadside Assistance

24-hour emergency road service is available to you in the United States and Canada throughout your 3-year/36,000-mile warranty term. Services include jump starting, flat tire and lockout assistance, towing, and more (limitations apply).

Call (866) 864-5211 (U.S.) or (800) 465-7587 (Canada)

TABLE OF CONTENTS

VISUAL INDEX	1	AUDIO AND CONNECTIVITY	50
Steering Wheel and Nearby Controls	1	Basic Audio Operation	50
Dashboard and Other Controls	2	Models with one display	54
SAFETY INFORMATION	3	One Display Audio Operation	54
Important Safety Information	3	FM/AM Radio	55
Seat Belts	5	Compact Disc (CD)	56
Airbags	8	iPod®	57
Child Safety	14	USB Flash Drive	58
Safety Label Locations	21	Bluetooth® Audio	59
Reporting Safety Defects	22	Pandora®	60
INSTRUMENT PANEL	23	Models with touchscreen	61
Malfunction Indicators	23	Touchscreen Operation	61
Condition Indicators	25	HondaLink®	63
On/Off Indicators	26	Wi-Fi Connection	64
Information Display*	27	Aha™ Radio	64
Multi-Information Display (MID)*	28	Apple CarPlay™	65
VEHICLE CONTROLS	30	Android Auto™	66
Using the Key or Remote Transmitter*	30	FM/AM Radio	67
Smart Entry System*	31	SiriusXM® Radio*	68
Door Operation	32	Compact Disc (CD)	69
Power Window Operation	33	iPod®	70
Power Moonroof Operation*	34	USB Flash Drive	71
Interior and Exterior Lights	35	Bluetooth® Audio	72
Auto High-Beam System*	36	Pandora®	73
Wiper Operation	37	BLUETOOTH® HANDSFREELINK® (HFL)	74
One-Touch Turn Signal	38	Models with one display	74
Adjusting the Seats	39	Basic HFL Operation	74
Adjusting the Steering Wheel	43	Pairing a Phone	75
Driving Position Memory System*	43	Making a Call	76
Adjusting the Mirrors	44	SMS Text Messaging	78
HomeLink® Universal Transceiver*	45	Models with touchscreen	79
Climate Control System	46	Basic HFL Operation	79
Seat Heaters*	47	Pairing a Phone	81
Customized Features	48	Making a Call	82
Setting the Clock	49	SMS Text Messaging and E-Mail*	84
		HondaLink® Assist	85
		Siri™ Eyes Free	86
		NAVIGATION*	87
		Basic Navigation Operation	87
		Entering a Destination	89
		Routing	92

*if equipped

VISUAL INDEX

Quickly locate items in the vehicle's interior.

Steering Wheel and Nearby Controls

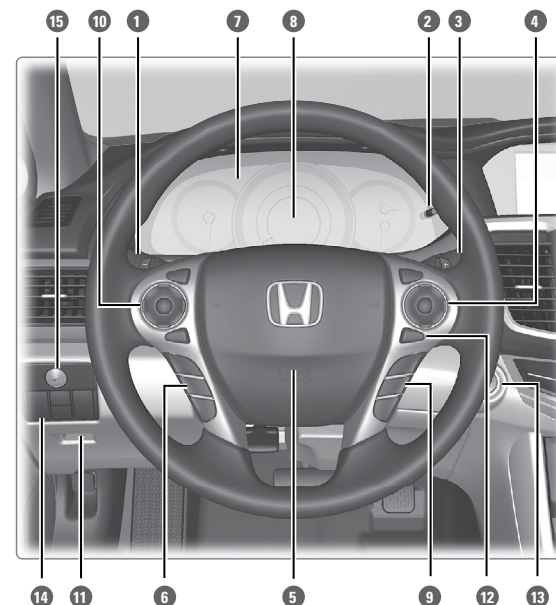

- 1 Lights/turn signals/LaneWatch button* p. 35, p. 38, p. 111
- 2 SEL/RESET knob p. 27
Brightness control p. 35
- 3 Wipers/washers p. 37
- 4 Cruise control buttons* p. 106
Adaptive Cruise Control (ACC) buttons* p. 106
Lane Keeping Assist System (LKAS) button* p. 110
- 5 Horn
- 6 Voice recognition buttons p. 74, p. 79, p. 87
- 7 Instrument panel p. 23
- 8 Information display* p. 27
Multi-information display* p. 28
- 9 Info (▲/▼) buttons* p. 28
SEL/RESET button* p. 28
- 10 Audio controls p. 52
- 11 Tire Pressure Monitoring System (TPMS) button p. 121
- 12 Lane Keeping Assist System (LKAS) button p. 110
- 13 ENGINE START/STOP button* p. 101
- 14 Vehicle Stability Assist (VSA) OFF button p. 105
Collision Mitigation Braking System (CMBS) OFF button* p. 112
Road Departure Mitigation (RDM) button* p. 109
Parking sensor system button* p. 113
- 15 ECON button p. 105

*if equipped

*if equipped

DRIVING	94	MAINTENANCE	129
Before Driving.....	94	Safety Precautions.....	129
Maximum Load Limit.....	96	Maintenance Minder™.....	130
Towing a Trailer.....	98	Under the Hood.....	132
Remote Engine Start*.....	99	Engine Oil.....	134
Starting to Drive.....	100	Engine Coolant.....	137
Shifting.....	101	Brake Fluid.....	138
Braking.....	104	Clutch Fluid*.....	138
Eco Assist System.....	105	Checking the Battery.....	139
Vehicle Stability Assist (VSA®).....	105	Window Washer Fluid.....	139
Cruise Control*.....	106	Changing Wiper Blades.....	140
Adaptive Cruise Control (ACC)*.....	107	Tire Information.....	141
Road Departure Mitigation (RDM)*.....	109	Tire Labeling.....	144
Lane Keeping Assist System (LKAS)*.....	110	DOT Tire Quality Grading.....	145
LaneWatch™*.....	111	Testing of Readiness Codes.....	147
Collision Mitigation Braking System™*.....	112	SPECIFICATIONS	148
Parking Sensor System*.....	113	CUSTOMER INFORMATION	151
Multi-View Rear Camera.....	114	Frequently Asked Questions/ Troubleshooting.....	151
Refueling.....	115	Contact Us.....	152
HANDLING THE UNEXPECTED	116	Honda Roadside Assistance.....	152
Smart Entry Remote Battery Strength*.....	116	Warranty Coverages.....	153
Shift Lever Does Not Move*.....	116	VOICE COMMAND INDEX	154
Jump Starting.....	117	INDEX	156
Overheating.....	119		
Emergency Engine Stop*.....	120		
Emergency Towing.....	120		
Tire Pressure Monitoring System (TPMS) ...	121		
Changing a Flat Tire.....	123		
Fuse Locations.....	126		

Dashboard and Other Controls

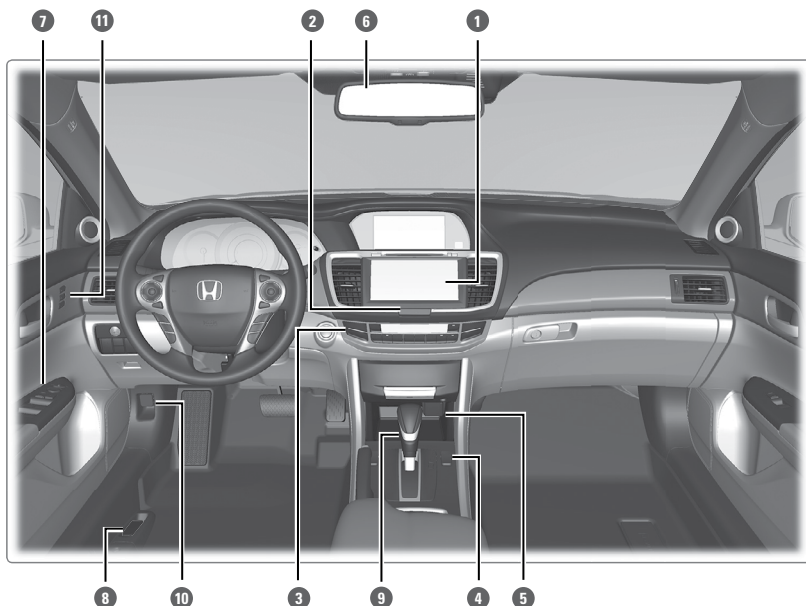

- | | |
|--|---|
| <p>1 Audio system/touchscreen*/ navigation* system p. 54, p. 79, p. 87</p> <p>2 Hazard warning button</p> <p>3 Climate control system p. 46</p> <p>4 Seat heater switches* p. 47</p> <p>5 USB port p. 50
Wireless charger* p. 51
Accessory power socket p. 50</p> <p>6 Rearview mirror p. 44</p> | <p>7 Power window switches p. 33
Door lock switches p. 32
Door mirror controls p. 45</p> <p>8 Fuel fill door release handle p. 115
Trunk release p. 32</p> <p>9 Shift lever p. 101</p> <p>10 Hood release handle p. 133</p> <p>11 Driving Position Memory System buttons* p. 43</p> |
|--|---|

*if equipped

SAFETY INFORMATION

Your safety—and the safety of others—is very important, and operating this vehicle safely is an important responsibility. While we strive to help you make informed decisions about safety, it is not practical or possible to warn you about all the hazards associated with operating or maintaining your vehicle. Therefore, you must use your own good judgment.

Important Safety Information

This guide explains many of your vehicle's safety features and how to use them. Please read this information carefully. Following the instructions below will also help to keep you and your passengers safe.

■ Important Safety Precautions

- Always wear your seat belt.
- Secure all children in the proper restraint system.
- Be aware of airbag hazards.
- Don't drink and drive.
- Pay appropriate attention to the task of driving safely.
- Control your speed.
- Keep your vehicle in safe condition.

Engaging in cell phone conversation or other activities that keep you from paying close attention to the road, other vehicles, and pedestrians could lead to a crash. Remember, situations can change quickly, and only you can decide when it is safe to divert some attention away from driving.

■ Safety Messages

When you see the following messages throughout this guide, pay close attention.

- ⚠ DANGER** You WILL be KILLED or SERIOUSLY HURT if you don't follow instructions.
- ⚠ WARNING** You CAN be KILLED or SERIOUSLY HURT if you don't follow instructions.
- ⚠ CAUTION** You CAN be HURT if you don't follow instructions.
- NOTICE** This information is intended to help you avoid damage to your vehicle, other property, or the environment.

■ Carbon Monoxide Gas

The engine exhaust from this vehicle contains carbon monoxide, a colorless, odorless, and highly toxic gas. As long as you properly maintain your vehicle and follow the instructions set forth below, you will not accumulate dangerous levels of carbon monoxide gas in the vehicle interior.

Have the exhaust system inspected for leaks whenever:

- The exhaust system is making an unusual noise.
- The exhaust system may have been damaged.
- The vehicle is raised for an oil change.

When you operate a vehicle with the trunk open, airflow can pull exhaust gas into the interior and create a hazardous condition. If you must drive with the trunk open, open all the windows and set the climate control system as shown below.

1. Select the fresh air mode.
2. Select the  mode.
3. Set the fan speed to high.
4. Set the temperature control to a comfortable setting.

Adjust the climate control system in the same manner if you sit in your parked vehicle with the engine running.

WARNING

Carbon monoxide gas is toxic. Breathing it can cause unconsciousness and even kill you.

Avoid any enclosed areas or activities that expose you to carbon monoxide.

An enclosed area such as a garage can quickly fill up with carbon monoxide gas. Do not run the engine with the garage door closed. Even when the garage door is open, drive out of the garage immediately after starting the engine.

Seat Belts

A seat belt is your best protection in all types of collisions. Airbags are designed to supplement seat belts, not replace them. So even though your vehicle is equipped with airbags, make sure you and your passengers always wear your seat belts and wear them properly.

■ Lap/Shoulder Seat Belts

All five seating positions are equipped with lap/shoulder seat belts with emergency locking retractors. In normal driving, the retractor lets you move freely while keeping some tension on the belt. During a collision or sudden stop, the retractor locks to restrain your body. The rear seat belts also have a lockable retractor for use with child seats.

The front seats are equipped with automatic seat belt tensioners to enhance safety. The tensioners automatically tighten the front seat belts during a moderate to severe frontal collision, sometimes even if the collision is not severe enough to inflate the front airbags.

■ Proper Use of Seat Belts

Follow these guidelines for proper use:

- All occupants should sit upright, well back in the seat, and remain in that position for the duration of the trip. Slouching and leaning reduce the effectiveness of the belt and can increase the chance of serious injury in a crash.
- Never place the shoulder part of a lap/shoulder seat belt under your arm or behind your back. This could cause very serious injuries in a crash.
- Two people should never use the same seat belt. If they do, they could be very seriously injured in a crash.
- Do not put any accessories on the seat belts. Devices intended to improve comfort or reposition the shoulder part of a seat belt can reduce the protective capability and increase the chance of serious injury in a crash.
- No one should sit in a seat with an inoperative seat belt or one that does not appear to be working correctly. Using a seat belt that is not working properly may not protect the occupant in a crash. Have a dealer check the belt as soon as possible.

WARNING

Not wearing a seat belt properly increases the chance of a serious injury or death in a crash, even though your vehicle has airbags.

Be sure you and your passengers always wear seat belts and wear them properly.

■ Seat Belt Inspection

Regularly check the condition of your seat belts as follows:

- Pull each belt out fully, and look for frays, cuts, burns, and wear.
- Check that the latches and buckles work smoothly and the belts retract easily. If a belt does not retract easily, cleaning the belt may correct the problem. Use only mild soap and warm water. Do not use bleach or cleaning solvents. Make sure the belt is completely dry before allowing it to retract.

Any belt that is not in good condition or working properly will not provide proper protection and should be replaced as soon as possible.

A belt that has been worn during a crash may not provide the same level of protection in a subsequent crash. Have your seat belts inspected by a dealer after any collision.

⚠ WARNING

Not checking or maintaining seat belts can result in serious injury or death if the seat belts do not work properly when needed.

Check your seat belts regularly and have any problem corrected as soon as possible.

■ Fastening a Seat Belt

Adjust your seat to the proper position (see page 39), and then follow the below steps.

1. Pull the seat belt out slowly.
2. Insert the latch plate into the buckle, then tug on the belt to make sure the buckle is secure. Make sure that the belt is not twisted or caught on anything.
3. Position the lap part of the belt as low as possible across your hips, then pull up on the shoulder part of the belt so the lap part fits snugly. This lets your strong pelvic bones take the force of a crash and reduces the chance of internal injuries.
4. If necessary, pull up on the belt again to remove any slack, then make sure that the belt rests across the center of your chest and over your shoulder. This spreads the forces of a crash over the strongest bones in your upper body.

To release the belt, push the red PRESS button then guide the belt by hand until it has retracted completely.

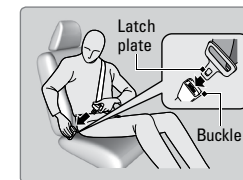
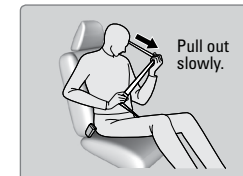

⚠ WARNING

Improperly positioning the seat belts can cause serious injury or death in a crash.

Make sure all seat belts are properly positioned before driving.

■ Adjusting the Shoulder Anchor

The front seats have adjustable shoulder anchors to accommodate taller and shorter occupants.

1. Move the anchor up and down while holding the release button.
2. Position the anchor so that the belt rests across the center of your chest and over your shoulder.

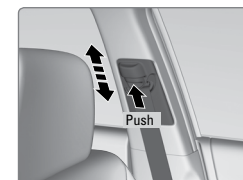

Airbags

Your vehicle is equipped with three types of airbags: front airbags, side airbags, and side curtain airbags.

■ Front Airbags (SRS)

The front SRS airbags inflate in a moderate-to-severe frontal collision to help protect the head and chest of the driver and/or front passenger. They are housed in the center of the steering wheel for the driver, and in the dashboard for the front passenger. Both airbags are marked **SRS AIRBAG**.

SRS (Supplemental Restraint System) indicates that the airbags are designed to supplement seat belts, not replace them. Seat belts are the occupant's primary restraint system.

■ Advanced Airbags

Your front airbags have advanced features to help reduce the likelihood of airbag-related injuries to smaller occupants.

The driver's advanced front airbag system includes a seat position sensor. Based on the seat position and crash severity, the system determines the optimal deployment of the driver's airbag.

If there is a problem with the driver's seat position sensor, the SRS indicator will come on and the airbag will inflate with full (normal) force, regardless of the driver's seating position.

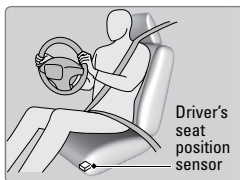

The passenger's advanced front airbag system has weight sensors. Although Honda recommends against carrying an infant or small child in front, if the sensors detect the weight of a child (up to 65 lbs or 29 kg), the system will automatically turn off the passenger's front airbag.

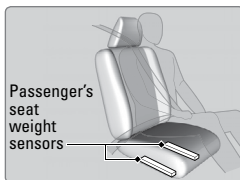

For both advanced front airbags to work properly:

- Do not spill any liquid on or under the seats.
- Do not put any object under the passenger's seat.
- Make sure any objects are positioned properly on the floor. Improperly positioned objects can interfere with the advanced airbag sensors.
- All occupants should sit upright and wear their seat belts properly.
- Do not place any cover over any part of the passenger side dashboard.

■ Side Airbags

The side airbags help protect the upper torso and pelvis of the driver or a front passenger during a moderate-to-severe side impact. They are housed in the outside edge of the driver's and front passenger's seat-backs. Both are marked **SIDE AIRBAG**.

■ Side Curtain Airbags

Side curtain airbags help protect the heads of the driver and passengers in outer seating positions during a moderate-to-severe side impact. The side curtain airbags equipped in this vehicle are also designed to help reduce the likelihood of partial and complete ejection of vehicle occupants through side windows in crashes, particularly rollover crashes.

The side curtain airbags are located in the ceiling above the side windows on both sides of the vehicle.

The side curtain airbags are designed to deploy in a rollover or moderate-to-severe side impact. If the SRS control unit senses that your vehicle is about to roll over, it immediately deploys both side curtain airbags and activates both front seat belt tensioners. If the impact is on the passenger's side, the passenger's side curtain airbag deploys even if there is no passenger in the passenger's seat.

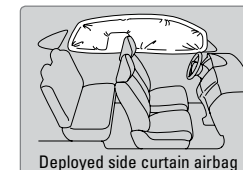
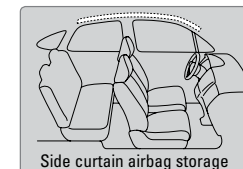

To get the best protection from the side curtain airbags, occupants should wear their seat belts properly and sit upright and well back in their seats.

Do not attach any objects to the side windows or roof pillars, as they can interfere with the proper operation of the side curtain airbags.

When side curtain airbags deploy in a frontal collision

One or both side curtain airbags may inflate in a moderate-to-severe angled frontal collision. In this case, the side curtain airbags will deploy slightly after the front airbags.

■ Important Facts About Your Airbags

Always wear your seat belt properly, and sit upright and as far back from the steering wheel as possible while allowing full control of the vehicle. A front passenger should move their seat as far back from the dashboard as possible.

Do not place hard or sharp objects between yourself and a front airbag. Carrying hard or sharp objects on your lap, or driving with a pipe or other sharp object in your mouth, can result in injuries if your front airbag inflates.

Do not attach or place objects on the front airbag covers. Objects on the covers marked **SRS AIRBAG** could interfere with the proper operation of the airbags or be propelled inside the vehicle and hurt someone if the airbags inflate.

Do not attach accessories on or near the side airbags. They can interfere with the proper operation of the airbags, or hurt someone if an airbag inflates.

Do not attach any objects to the side windows or roof pillars. They can interfere with the proper operation of the side curtain airbags.

Do not cover or replace the front seat-back covers. This can prevent your side airbags from properly deploying during a side impact.

⚠️ WARNING

An open glove box can cause serious injury to your passenger in a crash, even if the passenger is wearing the seat belt.

Always keep the glove box closed while driving.

■ Airbag System Indicators

If a problem occurs in the airbag system, the SRS indicator comes on and a message appears on the multi-information display*.

SRS (Supplemental Restraint System) indicator

If the indicator comes on at any other time besides vehicle start-up, or does not come on at all, have the system checked by a dealer as soon as possible. If you don't, your airbags and seat belt tensioners may not work properly when they are needed.

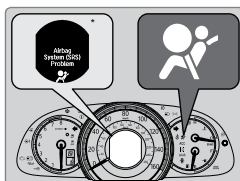

⚠️ WARNING

Ignoring the SRS indicator can result in serious injury or death if the airbag systems or tensioners do not work properly.

Have your vehicle checked by a dealer as soon as possible if the SRS indicator alerts you to a possible problem.

*if equipped

Passenger airbag off indicator

The indicator comes on to alert you that the front passenger's front airbag has been turned off. This occurs when the front passenger's weight sensors detect 65 lbs (29 kg) or less, the weight of an infant or small child, on the seat.

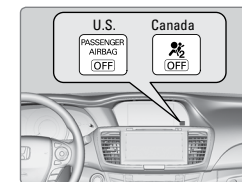

Infants and small children should always ride properly restrained in a back seat.

Objects placed on the seat can also cause the indicator to come on.

If the front passenger's seat is empty, the passenger's front airbag will not deploy and the indicator will not come on.

If the indicator comes on with no occupant or objects in the front passenger's seat, something may be interfering with the weight sensors, such as:

- An object hanging on the seat or in the seat-back pocket.
- A child seat or other object pressing against the rear of the seat-back.
- A rear passenger pushing or pulling on the back of the front passenger's seat.
- The front seat or seat-back is forced against an object on the seat or floor behind it.
- An object placed under the front passenger's seat.

If none of these conditions exist, have your vehicle checked by a dealer as soon as possible.

The passenger airbag off indicator may go on and off repeatedly if the total weight on the seat is near the airbag cutoff threshold.

Airbag System Components

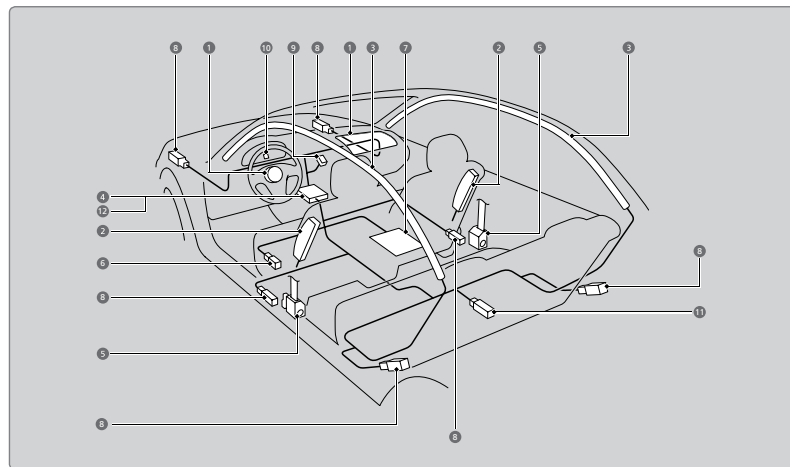

- 1 Two SRS (Supplemental Restraint System) front airbags. The driver's airbag is stored in the center of the steering wheel; the front passenger's airbag is stored in the dashboard. Both are marked **SRS AIRBAG**.
- 2 Two side airbags, one for the driver and one for the front passenger. The airbags are stored in the outer edges of the seat-backs. Both are marked **SIDE AIRBAG**.
- 3 Two side curtain airbags, one for each side of the vehicle. The airbags are stored in the ceiling, above the side windows. The front and rear pillars are marked **SIDE CURTAIN AIRBAG**.
- 4 An electronic control unit that continually monitors information about the various impact sensors, seat and buckle sensors, rollover sensor, airbag activators, seat belt tensioners, and other information while the vehicle is on. During a crash event the unit records such information.
- 5 Automatic front seat belt tensioners. The driver's and front passenger's seat belts incorporate sensors that detect whether or not they are fastened.
- 6 A driver's seat position sensor. If the seat is too far forward, the airbag will inflate with less force.
- 7 Weight sensors in the front passenger's seat. The front passenger's airbag will be turned off if the weight on the seat is 65 lbs (29 kg) or less (the weight of an infant or small child).
- 8 Impact sensors that can detect a moderate-to-severe front or side impact.
- 9 An indicator on the dashboard that alerts you that the front passenger's front airbag has been turned off.
- 10 An indicator on the instrument panel that alerts you to a possible problem with the airbag system or seat belt tensioners.

- 11 Safing sensor
- 12 A rollover sensor that detects whether the vehicle is about to roll over and signal the control unit to deploy both side curtain airbags.

Airbag Care

You do not need to, and should not, perform any maintenance on or replace any airbag system components yourself. However, you should have your vehicle inspected by a dealer in the following situations:

When the airbags have deployed

If an airbag has inflated, the control unit and other related parts must be replaced. Similarly, once an automatic seat belt tensioner has been activated, it must be replaced.

When the vehicle has been in a moderate-to-severe collision

Even if the airbags did not inflate, have your dealer inspect the following: the driver's seat position sensor, weight sensors in the passenger's seat, front seat belt tensioners, and each seat belt that was worn during the crash.

Do not remove or modify a front seat without first consulting a dealer

This would likely disable the driver's seat position sensor or the weight sensors in the passenger's seat. If it is necessary to remove or modify a front seat to accommodate a person with disabilities, contact a Honda dealer. For U.S. vehicles, call Honda Automobile Customer Service at (800) 999-1009. For Canadian vehicles, call Honda Canada Customer Relations at (888) 946-6329.

Child Safety

Each year, many children are injured or killed in vehicle crashes because they are either unrestrained or not properly restrained. In fact, vehicle collisions are the number one cause of death of children ages 12 and under.

The National Highway Traffic Safety Administration and Transport Canada recommend that all children ages 12 and under be properly restrained in a rear seat. Some states or provinces/territories have laws restricting where children may ride.

To reduce the number of child deaths and injuries, every state, Canadian province and territory requires that infants and children be properly restrained when they ride in a vehicle.

■ Protecting Child Passengers

- An inflating front or side airbag can injure or kill a child sitting in the front seat.
- A child in the front seat is more likely to interfere with the driver's ability to safely control the vehicle.
- Statistics show that children of all sizes and ages are safer when they are properly restrained in a rear seat.
- Any child who is too small to wear a seat belt correctly must be restrained in an approved child seat that is properly secured to the vehicle using either the lap belt portion of the lap/shoulder belt or the lower anchors of the LATCH system.
- Never hold a child on your lap because it is impossible to protect them in the event of a collision.
- Never put a seat belt over yourself and a child. During a crash, the belt would likely press deep into the child and cause serious or fatal injuries.
- Never let two children use the same seat belt. Both children could be very seriously injured in a crash.
- Do not allow children to operate the doors, windows, or seat adjusters.
- Do not leave children in the vehicle unattended, especially in hot weather when the inside of the vehicle can get hot enough to kill them. They could also activate vehicle controls, causing it to move unexpectedly.

⚠️ WARNING

Children who are unrestrained or improperly restrained can be seriously injured or killed in a crash.

Any child too small for a seat belt should be properly restrained in a child seat. A larger child should be properly restrained with a seat belt, using a booster seat if necessary.

⚠️ WARNING

Allowing a child to play with a seat belt or wrap one around their neck can result in serious injury or death.

Instruct children not to play with any seat belt and make sure any unused seat belt a child can reach is buckled, fully retracted, and locked.

■ Protecting Infants

An infant must be properly restrained in a rear-facing, reclining child seat until the infant reaches the seat maker's weight or height limit for the seat, and the infant is at least one year old. Many experts recommend use of a rear-facing seat for a child up to two years old if the child's height and weight are appropriate for a rear-facing seat.

Child seats must be placed and secured in a rear seating position. Rear-facing child seats should never be installed in a forward-facing position.

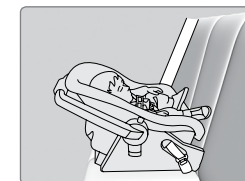

When properly installed, a rear-facing child seat may prevent the driver or a front passenger from moving their seat all the way back, or from locking their seat-back in the desired position. If this occurs, we recommend that you install the child seat directly behind the front passenger's seat, move the seat as far forward as needed, and leave it unoccupied. Or, you may wish to get a smaller rear-facing child seat.

⚠️ WARNING

Placing a rear-facing child seat in the front seat can result in serious injury or death during a crash.

Always place a rear-facing child seat in the rear seat, not the front.

■ Protecting Smaller Children

If a child is at least one year old and within the weight range indicated by the child seat manufacturer, the child should be properly restrained in a firmly secured forward-facing child seat.

We strongly recommend placing a forward-facing child seat in a rear seating position.

Placing a forward-facing child seat in the front seat can be hazardous, even with advanced front airbags that automatically turn the passenger's front airbag off. A rear seat is the safest place for a child.



⚠️ WARNING

Placing a forward-facing child seat in the front seat can result in serious injury or death if the front airbag inflates.

If you must place a forward-facing child seat in front, move the vehicle seat as far back as possible, and properly restrain the child.

■ Selecting a Child Seat

Most child seats are LATCH-compatible (Lower Anchors and Tethers for CHildren). Some have a rigid-type connector, while others have a flexible-type connector. Both are equally easy to use. Some existing and previously owned child seats can only be installed using the seat belt. Whichever type you choose, follow the child seat manufacturer's use and care instructions as well as the instructions in this manual. Proper installation is key to maximizing your child's safety.

In seating positions and vehicles not equipped with LATCH, a LATCH-compatible child seat can be installed using the seat belt and a top tether for added security. This is because all child seats are required to be designed so that they can be secured with a lap belt or the lap part of a lap/shoulder belt. In addition, the child seat manufacturer may advise that a seat belt be used to attach a LATCH-compatible seat once a child reaches a specified weight. Please read the child seat owner's manual for proper installation instructions.

Important considerations when selecting a child seat

Make sure the child seat meets the following three requirements:

- The child seat is the correct type and size for the child.
- The child seat is the correct type for the seating position.
- The child seat is compliant with Federal Motor Vehicle Safety Standard 213 or Canadian Motor Vehicle Safety Standard 213.

■ Installing a LATCH-Compatible Child Seat

A LATCH-compatible child seat can be installed in either of the two outer rear seats. A child seat is attached to the lower anchors with either the rigid or flexible type of connectors.

1. Locate the lower anchors under the marks.
2. Place the child seat on the vehicle seat, then attach the child seat to the lower anchors according to the instructions that came with the child seat. Make sure that the lower anchors are not obstructed by the seat belt or any other object.
3. Open the tether anchor cover behind the head restraint.
4. Raise the head restraint to its highest position, then route the tether strap between the head restraint legs, and secure the tether strap hook onto the anchor.
5. Tighten the tether strap according to the seat maker's instructions.
6. Make sure the child seat is firmly secured by rocking it forward and back and side to side; little movement should be felt.
7. Make sure any unused seat belt that a child can reach is buckled, the lockable retractor is activated, and the belt is fully retracted and locked.

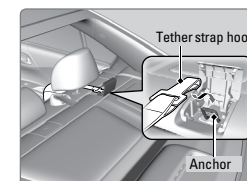
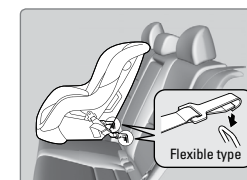
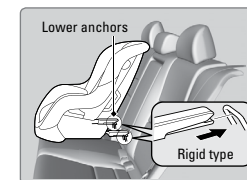
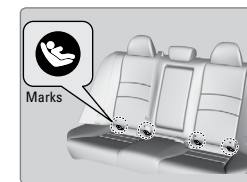

■ Installing a Child Seat with a Lap/Shoulder Seat Belt

1. Place the child seat on the vehicle seat.
2. Route the seat belt through the child seat according to the seat manufacturer's instructions, and insert the latch plate into the buckle. Insert the latch plate fully until it clicks.
3. Slowly pull the shoulder part of the belt all the way out until it stops. This activates the lockable retractor.
4. Let the seat belt retract a few inches, then try to pull it out to make sure the retractor is locked. If you are able to pull the shoulder belt out, the lockable retractor is not activated. Pull the seat belt all the way out, and repeat steps 3 – 4.
5. Grab the shoulder part of the seat belt near the buckle, and pull up to remove any slack from the lap part of the belt. When doing this, place your weight on the child seat and push it into the vehicle seat.
6. Make sure the child seat is firmly secured by rocking it forward and back and side to side; little movement should be felt.
7. Make sure any unused seat belt that a child can reach is buckled, the lockable retractor is activated, and the belt is fully retracted and locked.



To deactivate a lockable retractor, release the buckle and allow the seat belt to wind up all the way.

■ Adding Security with a Tether

A tether anchorage point is provided behind each rear seating position. A child seat that is installed with a seat belt and comes with a tether can use the tether for additional security.

1. Locate the appropriate tether anchorage point and lift the cover.
2. Raise the head restraint to its highest position, then route the tether strap through the head restraint legs. Make sure the strap is not twisted.
3. Secure the tether strap hook onto the anchor.
4. Tighten the tether strap according to the seat manufacturer's instructions.

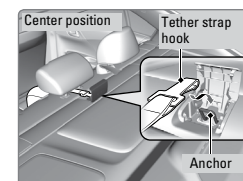
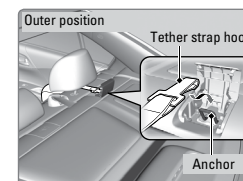
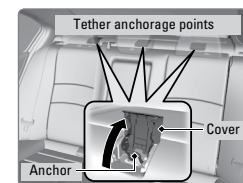

Protecting Larger Children

When a child is too big for a child seat, secure the child in a rear seat using the lap/shoulder seat belt.

Have the child sit upright and all the way back, then ensure the following:

- The child's knees bend comfortably over the edge of the seat.
- The shoulder belt crosses between the child's neck and arm.
- The lap part of the seat belt is as low as possible, touching the child's thighs.
- The child can stay seated for the whole trip.



If a lap/shoulder belt cannot be used properly, position the child in a booster seat in a rear seating position. For the child's safety, check that the child meets the booster seat manufacturer's recommendations.

Some U.S. states and Canadian provinces/territories require children to use a booster seat until they reach a given age or weight (e.g., 6 years or 60 lbs). Be sure to check current laws in the state or province/territory where you intend to drive.

WARNING

Allowing a child age 12 or under to sit in the front can result in injury or death if the passenger's front airbag inflates.

If a larger child must ride in front, move the vehicle seat as far to the rear as possible, then have the child sit up properly and wear the seat belt properly, using a booster seat if needed.

Safety Label Locations

Safety labels are in the locations shown. They warn you of potential hazards that can cause serious injury or death. Read these labels carefully.

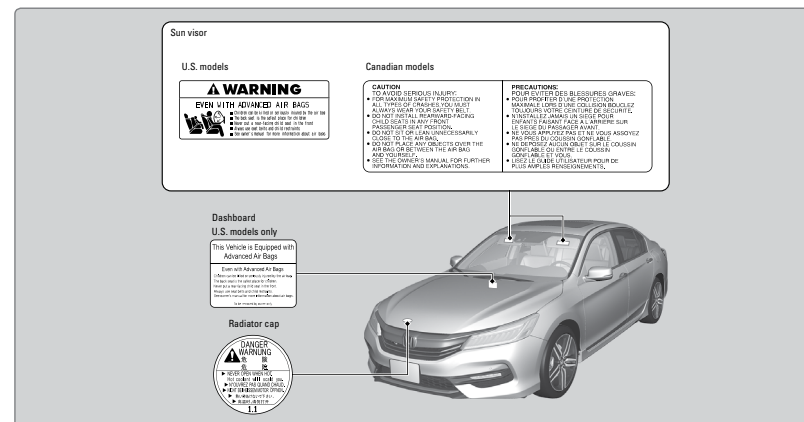

Reporting Safety Defects

In the U.S.

If you believe that your vehicle has a defect which could cause a crash or could cause injury or death, you should immediately inform the National Highway Traffic Safety Administration (NHTSA) in addition to notifying American Honda Motor Co., Inc.

If NHTSA receives similar complaints, it may open an investigation, and if it finds that a safety defect exists in a group of vehicles, it may order a recall and remedy campaign. However, NHTSA cannot become involved in individual problems between you, your dealer, or American Honda Motor Co., Inc.

To contact NHTSA, you may call the Vehicle Safety Hotline toll-free at 1-888-327-4236 (TTY: 1-800-424-9153); go to <http://www.safercar.gov>, or write to: Administrator, NHTSA, 1200 New Jersey Avenue, SE., Washington, DC 20590. You can also obtain other information about motor vehicle safety from <http://www.safercar.gov>.

In Canada

If you believe that your vehicle has a defect which could cause a crash or could cause injury or death, you should immediately inform Honda Canada, Inc., and you may also inform Transport Canada.

If Transport Canada receives similar complaints, it may open an investigation, and if it finds that a safety defect exists in a group of vehicles, it may lead to a recall and remedy campaign. However, Transport Canada cannot become involved in individual problems between you, your dealer, or Honda Canada, Inc.

To contact Transport Canada's Defect Investigations and Recalls Division, you may call 1-800-333-0510. For more information on reporting safety defects or about motor vehicle safety, go to <http://www.tc.gc.ca/roadsafety>.

INSTRUMENT PANEL

Learn about the indicators, gauges, and displays related to driving the vehicle.

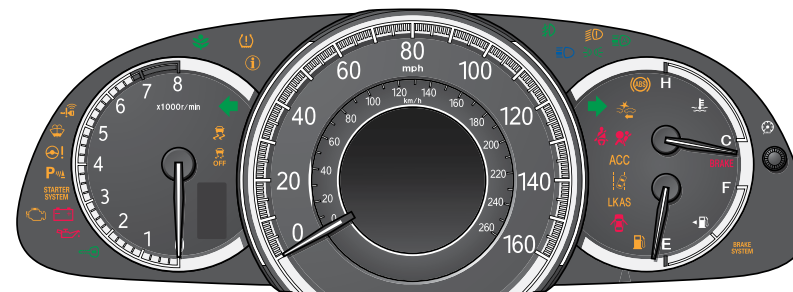

Indicators briefly appear with each engine start and then go out. Red and amber indicators are most critical. Blue and green indicators are used for general information.

Malfunction Indicators

These are the most critical indicators. If they come on and stay lit while driving or at any other time, there may be a problem. See your dealer if necessary.

BRAKE Brake system

U.S.

- Brake fluid is low.
- The brake system has a problem.



Canada

Press the brake pedal lightly to check pedal pressure. If normal, check the brake fluid level when you stop. If abnormal, take immediate action. If necessary, downshift the transmission to slow the vehicle using engine braking. Have your vehicle repaired immediately.



Low oil pressure

Engine oil pressure is low. Stop in a safe place. Open the hood. Check the oil level, and add oil if necessary (see page 134). If the indicator does not turn off, have your vehicle repaired immediately.



Charging system

The battery is not charging. Turn off all electrical items, but do not turn off the vehicle to prevent further battery discharge. Have your vehicle repaired immediately.



Supplemental Restraint System (SRS)

There is a problem with one of the airbag systems or seat belt tensioners.





Smart Entry system*

There is a problem with the smart entry system.

*if equipped

-  **Malfunction indicator lamp** (check engine light)
- The emissions control system may have a problem, or the fuel cap is loose or missing.
 - (Blinks) A misfire in the engine's cylinders is detected. Stop in a safe place, and wait for the engine to cool down.

-  **Anti-lock Brake System (ABS)**
- There is a problem with the anti-lock brake system. Your vehicle still has normal braking ability, but no anti-lock function.

-  **Tire Pressure Monitoring System (TPMS)**
- There is a problem with the tire pressure monitoring system, or the vehicle is fitted with the compact spare tire.

-  **Light control***
- There is a problem with the automatic lighting control system or low beam headlights.

-  **Parking sensor system***
- There is a problem with the system, or the sensor(s) are blocked.

-  **Collision Mitigation Braking System (CMBS)***
- There is a problem with the system, the temperature is too high, the camera is blocked or the radar is blocked.

-  **Vehicle Stability Assist (VSA)**
- There is a problem with the VSA system.

-  **Brake system**
- There is a problem with the brake system.

-  **Electric Power Steering (EPS)**
- There is a problem with the EPS system.

-  **Auto High-Beam System***
- There is a problem with the system, or the camera is blocked.

-  **Starter system***
- There is a problem with the starter system. If you cannot start the vehicle, press the brake pedal, then press and hold the ENGINE START/STOP button (see page 101) for 15 seconds.

-  **Adaptive Cruise Control (ACC)***
- There is a problem with the system, the temperature is too high, or the radar sensor is blocked.

*if equipped

-  **LKAS Lane Keeping Assist System (LKAS)***
- There is a problem with the system, the temperature is too high, or the camera is blocked.

-  **Road Departure Mitigation (RDM)***
- There is a problem with the system, the temperature is too high, or the camera is blocked.

Condition Indicators

These indicators may require you to perform an action.

-  **Parking brake**
- Release the parking brake before driving. You will hear a beep if you drive with it not fully released.

-  **Seat belt reminder**
- Make sure seat belts are fastened for you and all passengers. The indicator blinks and beeps sound continuously if you or your front passenger has not fastened your seat belts when you begin driving. If the indicator remains on after seat belts are fastened, see your dealer.

-  **Door open**
- A door is not closed. A beep sounds while driving if a door is open.

-  **Low fuel**
- Refuel as soon as possible. If the indicator blinks, there is a problem with the fuel gauge. See your dealer.

-  **Low tire pressure***
- Stop in a safe place, check tire pressures, and inflate tire(s) if necessary. The indicator also appears if your vehicle is fitted with the compact spare tire. Have your regular tire repaired or replaced as soon as possible.

-  **Washer fluid level** (Canadian models)
- The washer fluid is low. Refill the washer fluid (see page 139).

-  **System message***
- When a condition or malfunction indicator comes on, a message also appears on the multi-information display. Check the display for more information.













-  **Maintenance Minder***
- Scheduled maintenance for your vehicle is due (see page 131).

-  **Immobilizer**
- Your key or remote transmitter cannot be recognized by the vehicle. If the indicator blinks, you may not be able to start the engine. Turn the vehicle off, and then on again. If it continues to blink, there may be a problem with the system. See your dealer.

*if equipped

On/Off Indicators

These indicators remind you when an item is on or off.

-  VSA off
-  VSA engaged (blinking)
-  CRUISE MAIN on
-  CRUISE CONTROL on
-  ACC* on
-  LKAS* on
-  CMBS* off
-  Turn signals/hazards on
-  Fog lights* on
-  High beams on
-  Exterior lights on
-  Auto High-Beam System* on
-  ECON mode on

Information Display*

Consists of several displays that provide you with useful information.

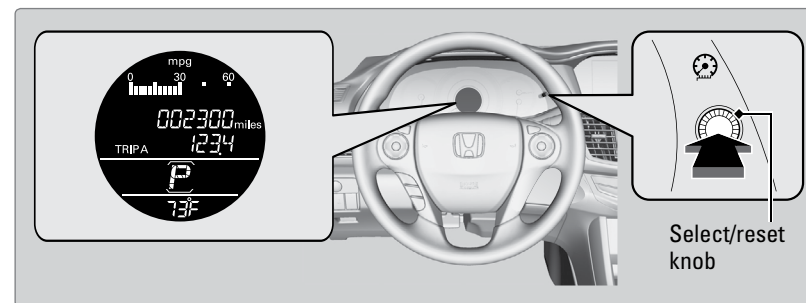

Press the select/reset knob to cycle through the displays shown below.

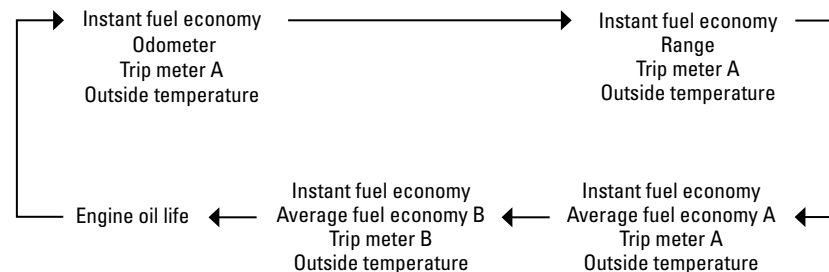

*if equipped

*if equipped

Multi-Information Display (MID)*

Consists of several displays that provide you with useful information.

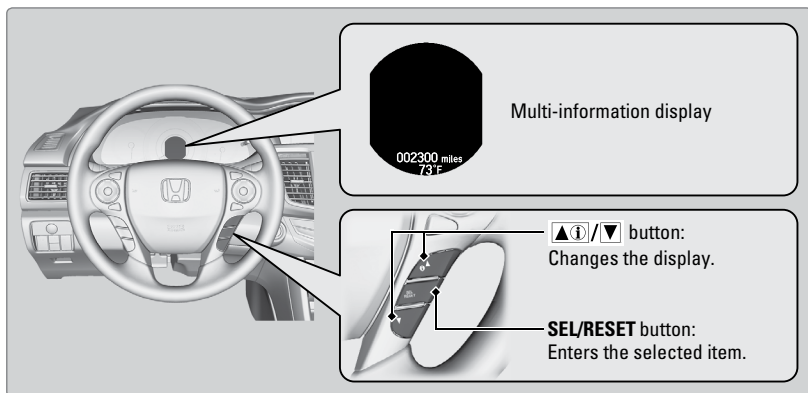

Main Displays

Press either Info (▲/▼) button to cycle through the displays shown below.

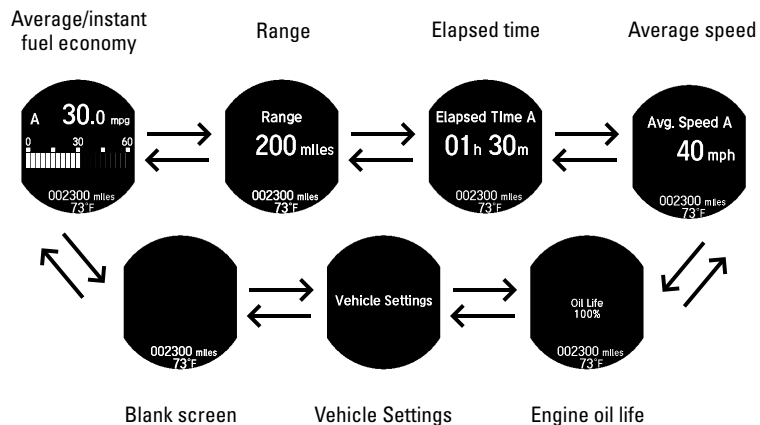

*if equipped

Lower Displays

Press the SEL/RESET button to cycle through the displays shown below.

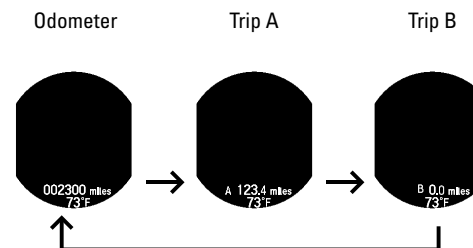

Vehicle Settings

Use the MID to customize certain vehicle features when the vehicle is in Park (P) or the parking brake is applied. You can also use the SETTINGS button* (see page 48).

An example of how to change the Trip A reset timing setting is below. Use the Info (▲/▼) and SEL/RESET buttons to make and enter selections.

1. Scroll to the Vehicle Settings menu and select it.



2. Scroll to Meter Setup and select it.

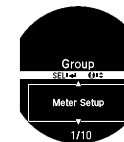

3. Scroll to "Trip A" Reset Timing and select it.



4. Scroll through the options, and select the one you want.



5. Scroll to Exit, and select it to exit the menus.

*if equipped

VEHICLE CONTROLS

Learn about the various controls necessary for operating and driving the vehicle.

Using the Key or Remote Transmitter*

Lock or unlock the doors and trunk.

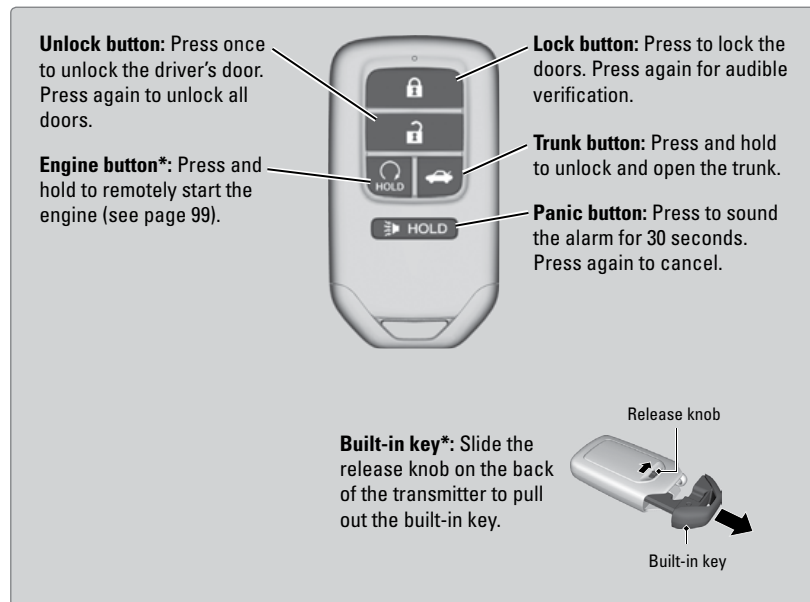

NOTICE

Leaving the key or remote transmitter in the vehicle can result in theft or accidental movement of the vehicle. Always take it with you whenever you leave the vehicle unattended.

*if equipped

Smart Entry System*

When you carry the remote transmitter (for example, in a pocket or purse) and it is outside the vehicle and within range (about 32 inches or 80 cm), you can lock or unlock the doors and trunk without handling the transmitter.

■ Unlocking/Locking the Doors

To unlock: Grab the driver's door handle when the vehicle is off to unlock the driver's door. Grab the front passenger's door handle to unlock all doors.

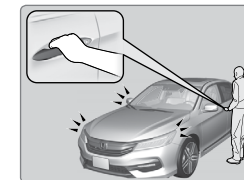

To lock: Press the door lock button on the front door handle when the vehicle is off. If the remote transmitter is inside the vehicle, the doors will not lock.

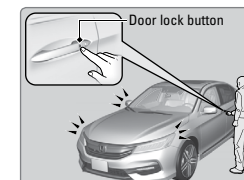

■ Unlocking the Trunk

Press the trunk release button to unlock and open the trunk.

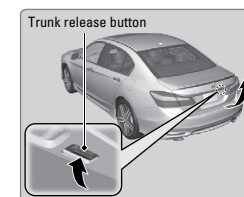

*if equipped

Door Operation

Use several methods to lock or unlock the doors.

Using the Lock Tab

To unlock: Pull the lock tab rearward. When you unlock the door using the lock tab on the driver's door, only the driver's door unlocks.

To lock: Push the lock tab forward. When you lock the door using the lock tab on the driver's door, all the other doors lock at the same time.

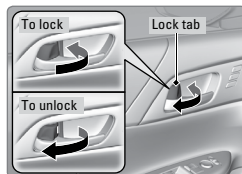

Using the Front Door Inner Handle

When you pull either front door inner handle, the door unlocks and opens. On vehicles with smart entry, pulling the driver's door inner handle unlocks all other doors.

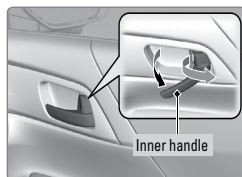

Using the Master Door Lock Switch

To unlock: Press the unlock side of the switch to unlock all doors.

To lock: Press the lock side of the switch to lock all doors.

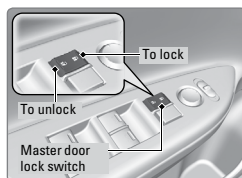

Childproof Door Locks

The childproof door locks prevent the rear doors from being opened from the inside regardless of the position of the lock tab.

Slide the lever in the rear door to the lock position, and close the door.

Open the door using the outer door handle.

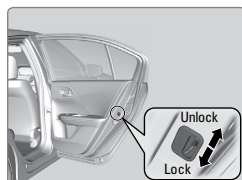

Using the Trunk Opener

Pull the trunk release near the bottom of the driver's seat to unlock and open the trunk.

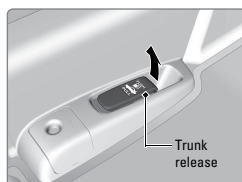

Power Window Operation

The power windows can be opened and closed when the vehicle is on by using the switches on the doors. The switches on the driver's side can be used to open and close all the windows.

Automatic Operation

To open: Push the switch down firmly.

To close: Pull the switch up firmly.

The window opens or closes completely. To stop the window at any time, push or pull the switch again briefly.

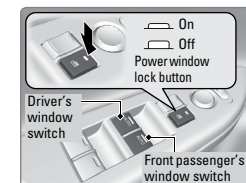

Manual Operation

To open: Push the switch down lightly.

To close: Pull the switch up lightly.

Release the switch when the window reaches the desired position.

Power Window Lock

Push in the power window lock button so only the driver's window can be operated.

WARNING

Closing a power window on someone's hands or fingers can cause serious injury.

Make sure your passengers are away from the windows before closing them.

Power Moonroof Operation*

The moonroof can be opened and closed when the vehicle is on by using the switch on the ceiling.

Automatic Operation

To open: Push the switch back firmly to the second detent, then release.

To close: Push the switch forward firmly to the second detent, then release.

The moonroof opens or closes completely. To stop the moonroof at any time, push the switch briefly.

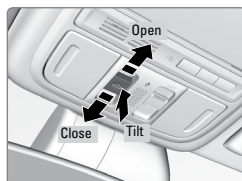

Manual Operation

To open: Push and hold the switch back to the first detent until the desired position is reached.

To close: Push and hold the switch forward to the first detent until the desired position is reached.

Moonroof Tilt

To tilt: Push the center of the switch.

To close: Push the switch forward firmly, then release.

WARNING

Closing the moonroof on someone's hands or fingers can cause serious injury. Make sure your passengers are away from the moonroof before closing it.

NOTICE

Opening the moonroof in below freezing temperatures or when it is covered with snow or ice can damage the moonroof panel or motor.

*if equipped

Interior and Exterior Lights

Operate interior and exterior lights when the vehicle is on or off.

Brightness Control

Adjust instrument panel brightness when the vehicle is on.

To brighten: Turn the knob to the right.

To dim: Turn the knob to the left.

A beep sounds when the brightness reaches its minimum or maximum.

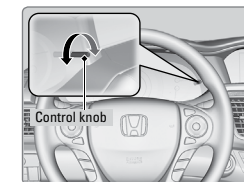

Interior Lights

Change the interior light settings using the switch on the ceiling.

ON position (rear): Interior lights remain on.

Door-activated position: Interior lights come on when any of the doors are opened, the driver's door is unlocked, or the vehicle is turned off.

OFF position: Interior lights remain off.

Map lights: Press the map lights to turn on or off.

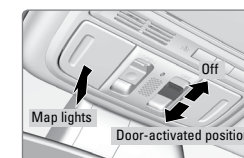

Exterior Lights

Rotate the switches on the headlight lever to operate the exterior lights.

OFF: All exterior lights are off.

☞☞: Turn on exterior lights except headlights.

AUTO: Turn on the automatic lighting feature. Headlights turn on or off depending on ambient brightness when the vehicle is on. Headlights automatically come on after the wipers are engaged for a certain time.*

☞☞☞: Turn on all exterior lights including headlights.

☞☞☞☞: Turn on fog lights* on or off.

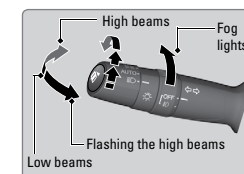

*if equipped

Auto High-Beam System*

Automatically changes the low beam headlights to high beam headlights when necessary.

How It Works

When you are driving at night above 25 mph (40 km/h) and the headlight lever is in the low beam position with the switch rotated to AUTO, the system changes between low and high beams depending on the surrounding conditions.

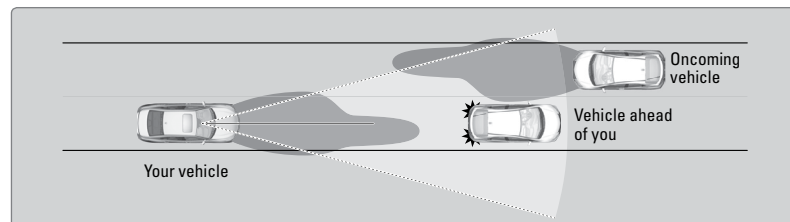

If a vehicle is detected ahead of you, the headlights stay in low beams. If the system does not detect any vehicles ahead of you, the headlights change to high beams.

Certain conditions, such as weather and brightness of other vehicles' lights, can affect system operation.

Turning the System On or Off

Make sure the headlight lever is in the low beam position with the switch rotated to the AUTO position. The auto high-beam system indicator comes on.

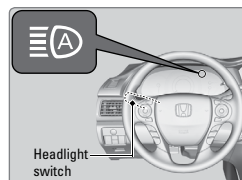

The system is canceled temporarily when you drive at speeds below 15 mph (24 km/h), the vehicle speed is below 6 mph (10 km/h), or the windshield wipers run at high speed for more than a few seconds.

To disable the system: When the vehicle is on and parked, pull the headlight lever towards you and hold it for 40 seconds. The auto high-beam indicator blinks twice.

To re-enable the system: Pull the headlight lever towards you and hold it for 30 seconds. The auto high-beam indicator blinks once.

To temporarily cancel operation, do either of the following:

- Flash the high beams by moving the lever toward you. Flash the high beams again to resume auto high beam operation.
- Engage high beams by moving the lever into the high beam position. Return the lever to the low beam position to resume auto high beam operation.

*if equipped

Using the Auto High-Beam System

If you find the timing of beam changes inconvenient for driving, change the headlight beams manually.

If the Can Not Operate:  message appears, park your vehicle in a safe place. Wipe away debris blocking the windshield, then start driving again. If the message remains on even after driving for a while with the clean windshield, have your vehicle checked by a dealer.

For the auto high-beam system to work properly:

- Do not place an object that reflects light on the dashboard.
- Keep the windshield around the camera clean.
- When cleaning the windshield, be careful not to apply the windshield cleanser to the camera lens.
- Do not attach an object, sticker or film in the area around the camera.
- Do not touch the camera lens.
- If the camera receives a strong impact, or repairing of the area near the camera is required, consult a dealer.

Wiper Operation

The windshield wipers and washers can be used when the vehicle is on.

Move the wiper lever up or down to the desired position.

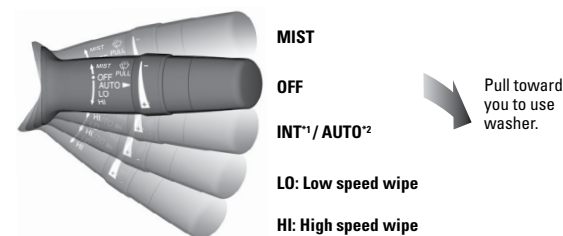

Headlight-Wiper Integration*

When the headlights are in the AUTO position, they automatically turn on when the front wipers operate several times within a certain interval. The headlights turn off shortly after the wipers are turned off, or if there is enough ambient light.

Intermittent (INT) Wipers*

When you move the lever to the INT position, the wipers operate based on the delay adjustment.

Rotate the adjustment ring to adjust the wiper delay.

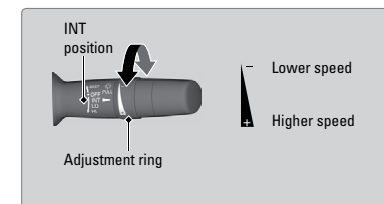

*1: models without automatic intermittent wipers

*2: models with automatic intermittent wipers

Automatic Intermittent Wipers*

When you move the lever to the AUTO position while driving in rainy weather, the wipers operate based on the amount of detected rainfall.

Put the lever in the AUTO position only when driving in rainy weather.

Rotate the adjustment ring to adjust the rainfall sensor sensitivity.

Return the lever to the OFF position when rain stops.

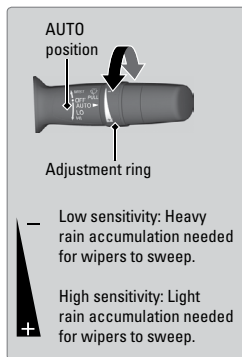

NOTICE

To prevent severe damage to the windshield wiper system, ensure the wiper lever is in the OFF position before entering a car wash or cleaning the windshield.

NOTICE

Do not use the wipers when the windshield is dry. The windshield will get scratched, or the rubber blades will get damaged.

In cold weather, the blades may freeze to the windshield, becoming stuck. Operating the wipers in this condition may damage the wipers. Use the defroster to warm the windshield, or manually clear the windshield of ice and snow before turning on the wipers.

One-Touch Turn Signal

Use this quick and convenient method to signal a lane change.

Lightly push the turn signal lever up or down for a three-blink sequence.

For a continuous signal, push the lever up or down until it locks into place.

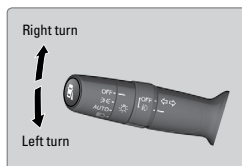

**if equipped*

Adjusting the Seats

Make seat adjustments before driving to ensure the best comfort and safety.

Adjusting the Front Seats

Adjust the driver's seat as far back as possible while allowing you to maintain full control of the vehicle. You should be able to sit upright and well back in the seat, adequately press the pedals without leaning forward, and grip the steering wheel comfortably. The passenger's seat should be adjusted so that it is as far back from the front airbag in the dashboard as possible.

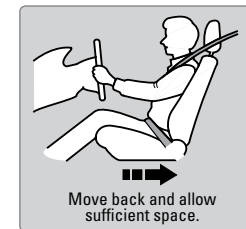

The National Highway Traffic Safety Administration and Transport Canada recommend that drivers allow at least 10 inches (25 cm) between the center of the steering wheel and the chest.

Power Seats*

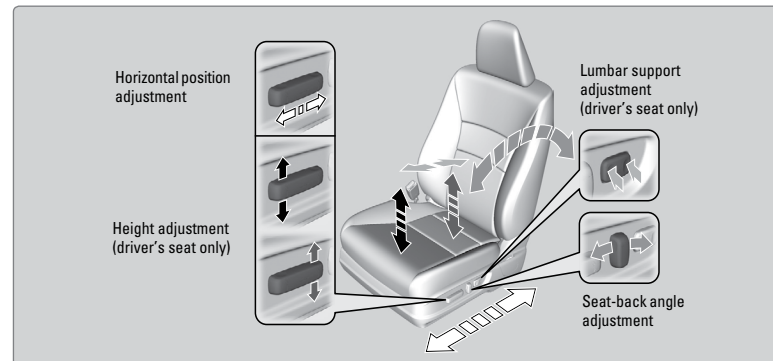

WARNING
Reclining the seat-back too far can result in serious injury or death in a crash. Adjust the seat-back to an upright position, and sit well back in the seat.

WARNING
Sitting too close to a front airbag can result in serious injury or death if the front airbags inflate. Always sit as far back from the front airbags as possible while maintaining control of the vehicle.

**if equipped*

Manual Seats*

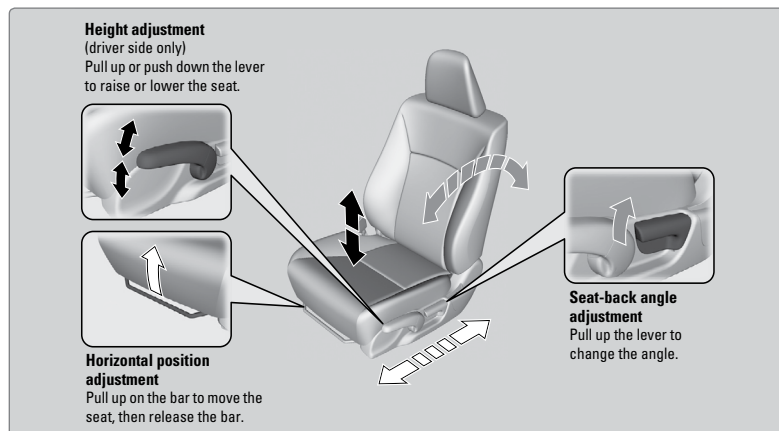

⚠ WARNING

Sitting improperly or out of position can result in serious injury or death in a crash.

Always sit upright, well back in the seat, with your feet on the floor.

Floor Mats

Position the front- and rear-seat floor mats properly, and anchor them. If they are not properly positioned, the floor mats can interfere with the front seat functions.

Do not put additional floor mats on top of the anchored mats.

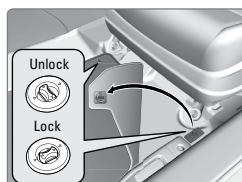

*if equipped

Adjusting the Head Restraints

Your vehicle is equipped with head restraints in all seating positions. Head restraints are most effective for protection against whiplash and other rear-impact crash injuries.

The center of the back of the occupant's head should rest against the center of the restraint. The tops of the occupant's ears should be level with the center height of the restraint.

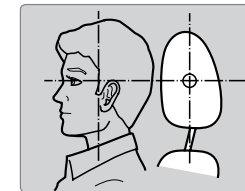

To raise the head restraint: Pull it upward.

To lower the head restraint: Push it down while pressing the release button.

To remove the head restraint: Pull the restraint up as far as it will go. Then push the release button, and pull the restraint up and out.

To reinstall a head restraint: Insert the legs back in place, then adjust the head restraint to an appropriate height while pressing the release button. Pull up on the restraint to make sure it is locked in position.

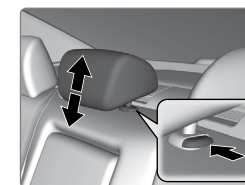
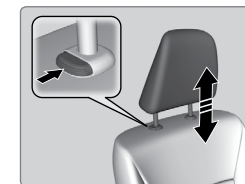

For a head restraint system to work properly:

- Do not hang any items on the head restraints, or from the restraint legs.
- Do not place any object between an occupant and the seat-back.
- Install each restraint in its proper location.

⚠ WARNING

Improperly positioning head restraints reduces their effectiveness and increases the likelihood of serious injury in a crash.

Make sure head restraints are in place and positioned properly before driving.

⚠ WARNING

Failure to reinstall, or correctly reinstall, the head restraints can result in severe injury during a crash.

Always replace the head restraints before driving.

Folding Down the Rear Seats

The rear seat-back(s^{*}) can be folded down to make room for large items in the trunk.

1. Remove the center shoulder belt from the guide.

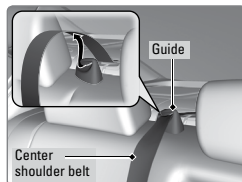

2. Pull the release lever in the trunk to release the lock.

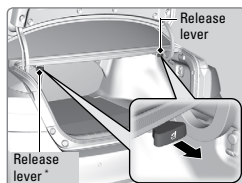

3. Fold down the seat-back. Remove the rear head restraints if necessary (see page 41). Push the seat-back up firmly until it locks into place to return it to its original position.

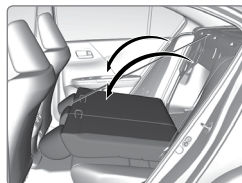

Make sure all items in the trunk or items extending through the opening into the rear seats are properly secured. Loose items can fly forward if you have to brake hard.

**if equipped*

Adjusting the Steering Wheel

The steering wheel height and distance from your body can be adjusted so that you can comfortably grip the steering wheel in an appropriate driving posture.

1. Pull up the steering wheel adjustment lever.
2. Move the steering wheel up or down, and in or out.
3. Push down the steering wheel adjustment lever to lock the steering wheel in position.

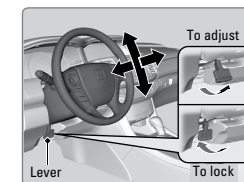

WARNING

Adjusting the steering wheel position while driving may cause you to lose control of the vehicle and be seriously injured in a crash.

Adjust the steering wheel only when the vehicle is stopped.

Driving Position Memory System*

You can store two driver's seat positions into memory when the vehicle is on using the buttons on the driver's door.

1. Adjust the seat to your preferred position.
2. Press SET.
3. Press and hold memory button 1 or 2. You will hear two beeps when the memory is set.
4. Press one of the memory buttons to recall previously stored positions.

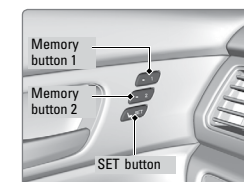

Lumbar positions cannot be stored.

When you unlock and open the driver's door with a remote transmitter, the seat adjusts automatically to one of the two preset positions.

**if equipped*

Adjusting the Mirrors

Adjust the angle of the mirrors for the best visibility when you are sitting in the correct driving position.

Rearview Mirror with Day/Night Positions*

Manually adjust the position to reduce headlight glare from vehicles behind you. Flip the tab to switch between day and night positions.

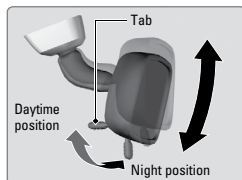

Automatic Dimming Rearview Mirror*

When driving after dark, the automatic dimming function reduces the glare from headlights behind you.

The function cancels when the shift lever is in Reverse (R).

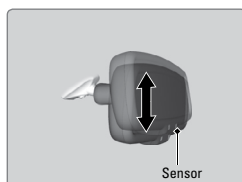

Power Door Mirrors

Adjust the power door mirrors when the vehicle is on.

L/R selector switch: Select the left or right mirror. After adjusting the mirror, return the switch to the center position.

Mirror position adjustment switch: Press the switch left, right, up, or down to move the mirror.

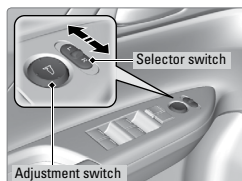

HomeLink® Universal Transceiver*

Program your vehicle to operate up to three remote-controlled devices around your home—such as garage doors, lighting, or home security systems—using the buttons on the ceiling.

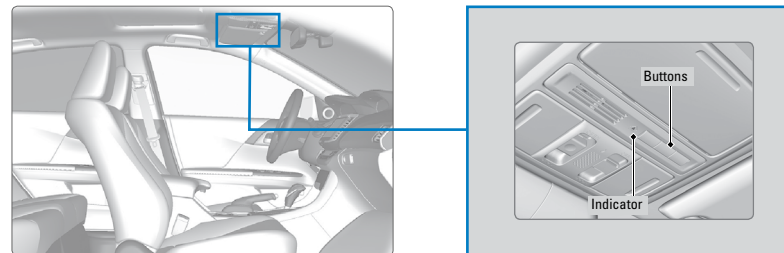

Training a Button

Park near the system you want to program, and follow the instructions in the flowchart below.

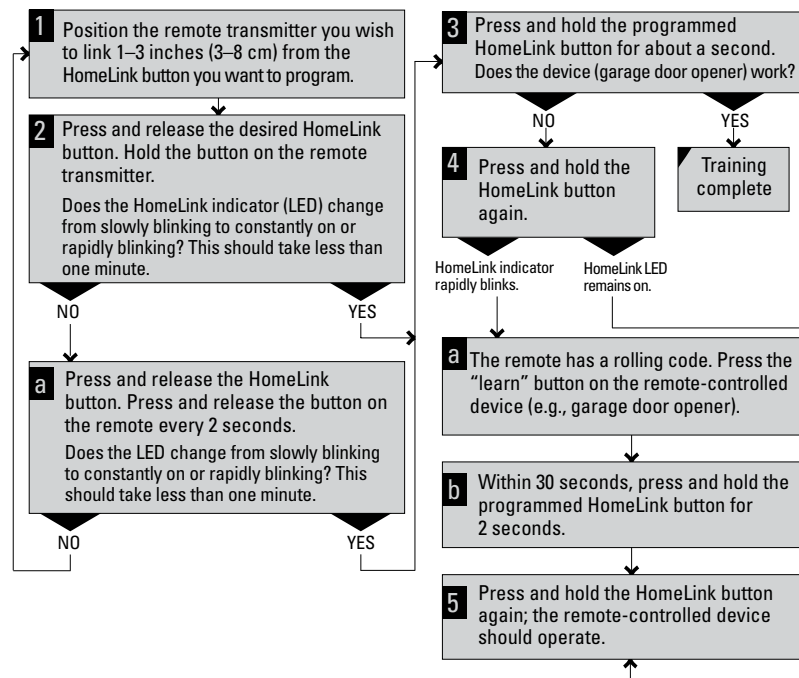

To retrain a button or erase codes, see the Owner's Manual on the Owner Information CD or at owners.honda.com (U.S.) or www.myhonda.ca (Canada). If you need help, visit www.homelink.com or call (800) 355-3515.

*if equipped

*if equipped

TABLE OF CONTENTS
VISUAL INDEX
SAFETY INFORMATION
INSTRUMENT PANEL
VEHICLE CONTROLS
AUDIO AND CONNECTIVITY
BLUETOOTH® HANDSFREE/INK®
HONDALINK®

NAVIGATION
DRIVING
HANDLING THE UNEXPECTED
MAINTENANCE
SPECIFICATIONS
CUSTOMER INFORMATION
VOICE COMMAND INDEX
INDEX

Climate Control System

The automatic climate control system can maintain your preferred interior temperature by selecting the proper mix of heated or cooled air and fan speed. Use the buttons on the dashboard to control the system.

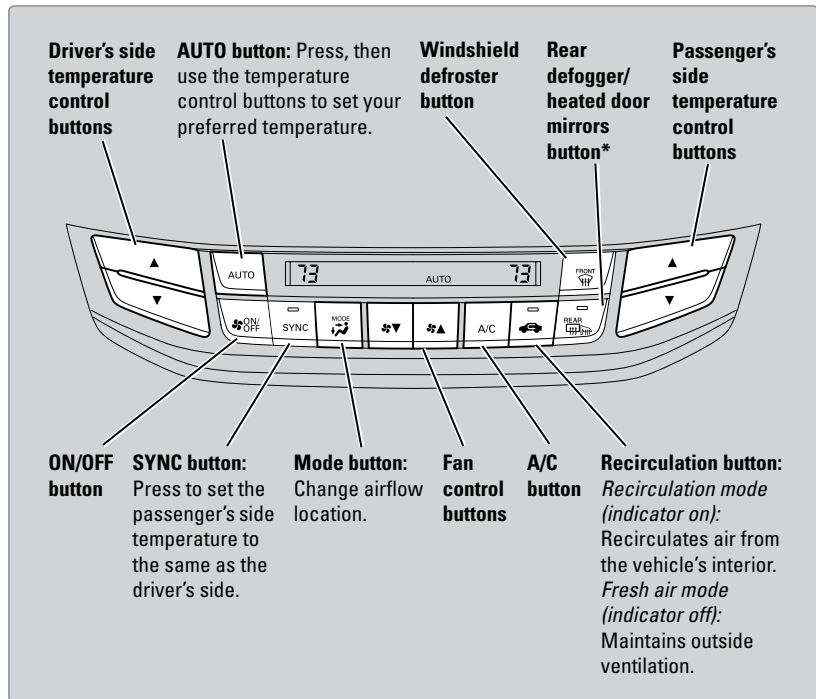

Seat Heaters*

Quickly warm the seats when the vehicle is on.

Press the seat heater switch to the LO or HI position. An indicator appears for the selected setting. Return the switch to the middle position to turn off. The switch for the front seat heaters is located in the front console.

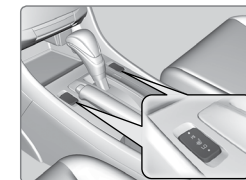

The switch for the rear seat heaters is located on the rear door. The rear middle seat does not have heating.



⚠ WARNING

Heat-induced burns are possible when using seat heaters. Persons with a diminished ability to sense temperature (e.g., persons with diabetes, lower-limb nerve damage, or paralysis) or with sensitive skin should not use the seat heaters.

*if equipped

TABLE OF CONTENTS

VISUAL INDEX

SAFETY INFORMATION

INSTRUMENT PANEL

VEHICLE CONTROLS

AUDIO AND CONNECTIVITY

BLUETOOTH® HANDSFREELINK®

HONDALINK®

NAVIGATION

DRIVING

HANDLING THE UNEXPECTED

MAINTENANCE

SPECIFICATIONS

CUSTOMER INFORMATION

VOICE COMMAND INDEX

INDEX

Customized Features

Use the Settings menu to customize certain features when the vehicle is stopped.

Using the SETTINGS Button*

Use the selector knob to make and enter selections.

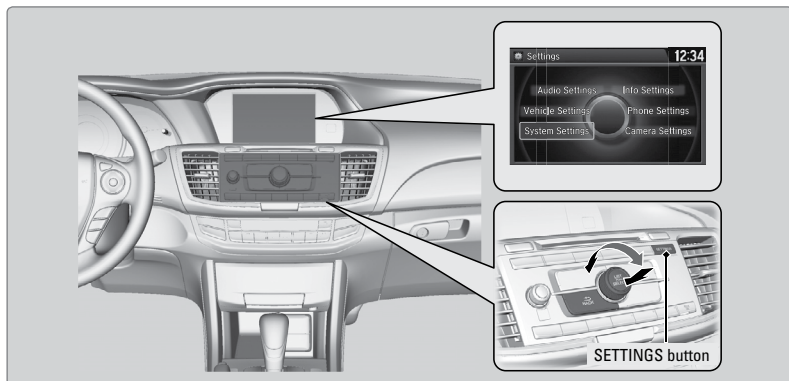

1. Press the SETTINGS button.
2. Select an option, and make your preferred changes.
3. Press the BACK button to exit the menus.

Using the Touchscreen*

Select items on the touchscreen to make selections.

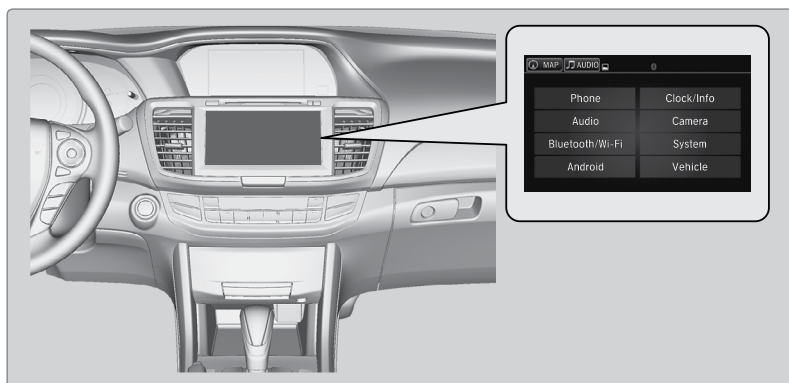

1. From the HOME screen, select Settings.
2. Select an option, and make your preferred changes.
3. Press BACK to exit the menus.

*if equipped

Customization Example: Door Lock/Unlock Settings

To customize the door lock/unlock settings, follow the steps below when the vehicle is stopped and the power mode is ON. Use the audio/information screen.

1. Press HOME
2. Press Settings
3. Press Vehicle
4. Press Door/Window Setup
 - To customize door lock settings, press Auto Door Lock
 - To customize door unlock settings, press Auto Door Unlock
5. Choose a setting
 - The default lock setting is Shift from Park
 - The default unlock setting is All Doors when Driver's Door Opens
 - Press the BACK or HOME button when you are done

Setting the Clock

Adjust the time using the steps described for your vehicle type.

Using the SETTINGS Button*

Use the selector knob to make and enter selections.

1. Press the SETTINGS button.
2. Select System Settings.
3. Select Clock.
4. Select Clock Adjustment.
5. Change the hour and minute values.
6. Press the BACK button to exit the menus.

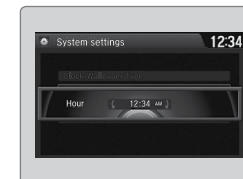

Using the Touchscreen*

Touch items to make selections.

1. From the HOME screen, select Settings.
2. Select Clock/Info.
3. Select Clock Adjustment.
4. Adjust the hour and minute values.
5. Select OK when complete.

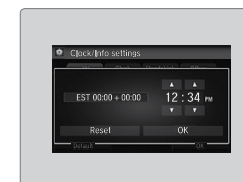

On vehicles with navigation, the time is automatically set using GPS signals.

*if equipped

AUDIO AND CONNECTIVITY

Learn how to operate the vehicle's audio system.

Basic Audio Operation

Connect audio devices and operate buttons and displays for the audio system.

■ USB Port

Connect a USB flash drive or other audio device, such as an iPod or iPhone®. Install the flash drive or cable connector to the USB port.

Models with one display

The USB port (1.0 A) is in the front console and is for playing audio and charging devices.

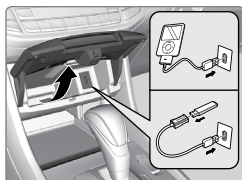

Models with two displays

The USB port (1.5 A) in the front console is for playing audio, charging devices, and connecting to Apple CarPlay (see "Apple CarPlay™" on page 65) or Android Auto (see "Android Auto™" on page 66).

The USB port (1.0 A) in the center console is for playing audio and device charging.

■ Auxiliary Input Jack*

Connect standard audio devices with a 1/8-inch (3.5 mm) stereo miniplug.

1. Open the AUX cover on the audio panel.
2. Insert the miniplug attached to the audio device into the jack. The audio system switches to AUX mode. Use the device to control the audio.

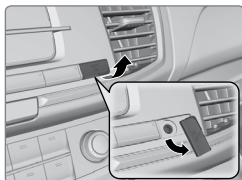

Applicable laws may prohibit the operation of handheld electronic devices while operating a vehicle.

■ Accessory Power Socket

Open the socket cover in the front console to use power when the vehicle is on.

There is an additional power socket inside the center console.

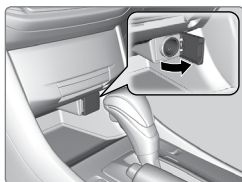

NOTICE

Do not insert an automotive type cigarette lighter element. This can overheat the power socket.

*iPod and iPhone are trademarks of Apple, Inc. *if equipped*

■ Wireless Charger*

Canadian models

Charge your Qi®-compatible device when the vehicle is on.

1. Press and hold the power button. A green indicator appears when the charger is on.
2. Place the chargeable side of the device on the charge area. The system begins charging the device when the amber indicator appears.
3. The green indicator appears when charging is complete. On some devices, the amber indicator may stay on even when charging is complete.

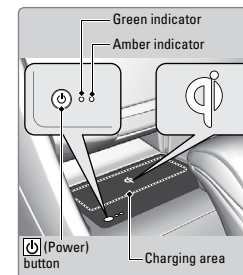

Notes:

- This system consumes a lot of power. It is best to charge your device when the engine is running.
- If the indicator light is blinking, there may be an obstacle between the device and charging area, the device may have moved, or the charger is malfunctioning.
- The device may not charge if you are near strong electromagnetic waves, such as at a gas station.
- The device and charging area may get warm during charging. This is normal.

CAUTION

Metal objects between the charge pad and the device to be charged will get hot and can burn you.

- Always remove foreign objects from the charge pad before charging the device.
- Be sure the surface is clear of dust and other debris before charging.

NOTICE

- Do not place any magnetic devices, credit cards, or watches within the charge area while charging. The data on credit cards can be lost, and watches may stop working.
- Do not spill liquids (i. e. water, drinks, etc.) on the charger and the device.
- Do not use oil, grease, alcohol, benzine or thinner for cleaning the charge pad.
- Do not cover the system with towels, clothing, or other objects while charging etc.
- Avoid spraying aerosols which may contact the charge pad surface.

**If equipped. Qi is a registered trademark of the Wireless Power Consortium.*

Steering Wheel Controls

You can operate certain functions of the audio system using the steering wheel controls.

SOURCE button: Cycle through available audio modes.

◀/▶ buttons: Change presets, tracks, albums, or folders.

+ / - buttons: Adjust audio volume.

MENU button*: On vehicles with touchscreen, press to view options for the current audio source. Use the other buttons to navigate through the options.

FM/AM/SiriusXM Radio

Press ▶ or ◀ for the next or previous station.

Press and hold ▶ or ◀ for the next or previous strong station.

CD/iPod/USB/Bluetooth Audio

Press ▶ or ◀ for the next or previous track.

Press and hold ▶ or ◀ for the next or previous folder (CD/USB).

Pandora (U.S. only)

Press ▶ for the next song.

Press and hold ▶ or ◀ for the next or previous station.



*if equipped

Adjusting the Sound

Adjust various sound settings.

Using the SETTINGS button*

Use the selector knob to make and enter selections.

1. Press the SETTINGS button.
2. Select Audio Settings.
3. Select Sound.
4. Select a sound mode to change, and adjust it using the selector knob.
5. Press the BACK button to exit the menu.



Using the touchscreen*

Touch items on the screen to make and enter selections.

1. From the HOME screen, select Settings.
2. Select Audio.
3. Select Sound.
4. Select the tabs to change the sound mode and adjust the setting.
5. Select OK when complete.

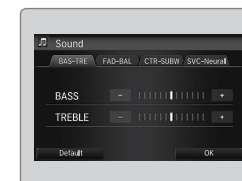

*if equipped

Models with one display

One Display Audio Operation

Control audio operation using the dashboard buttons.

*** button:** Adjust display brightness.

Power/volume knob: Press to turn the audio system on or off. Rotate to adjust volume.

BACK button: Return to the previous screen.

SETTINGS button: Display settings options.

Selector knob: Rotate and press to make and enter selections.

MENU button: Display menu items for the selected audio mode.

Main display

12:34

Press the display button to change displays.

Models with one display

FM/AM Radio

Play FM or AM radio stations.

FM/AM button: Select a band.

Preset buttons (1-6): Press and hold a preset button to store the current station. Press a preset button to select a previously stored station.

Seek/Skip buttons: Find the next or previous strong station.

Selector knob: Rotate to tune radio frequency.

FM/AM radio display

FM 12:34

97.9 MHz

Models with one display

Compact Disc (CD)

The audio system supports audio CDs, CD-Rs, and CD-RWs in MP3, WMA, or AAC formats.

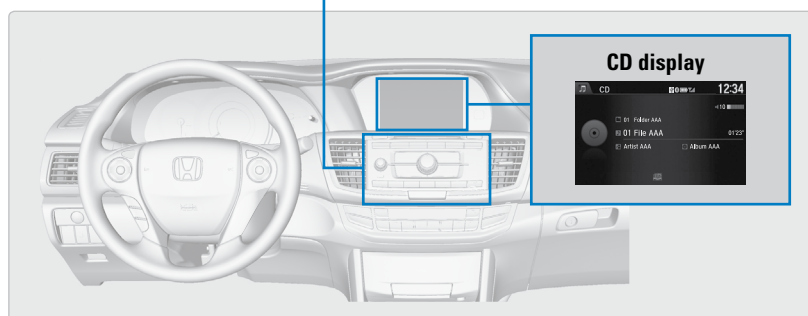
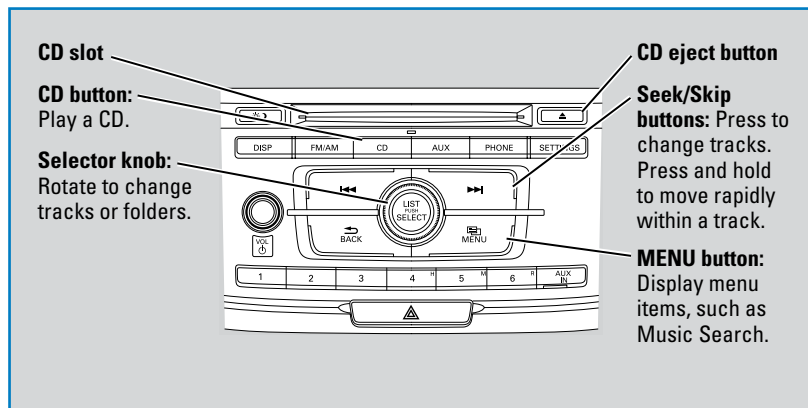

■ Searching for Music

Use the selector knob to search for tracks stored on the CD.

1. From the audio screen, press the MENU button.
2. Select Music Search.
3. Select the folder or track you want to play.



NOTICE

Do not use CDs with adhesive labels or insert a damaged CD. Inserting these types of CDs may cause them to get stuck or damage the audio unit.

Models with one display

iPod®

Play and operate an iPod through the vehicle's audio system. Connect your device to the USB port (see p. 50).

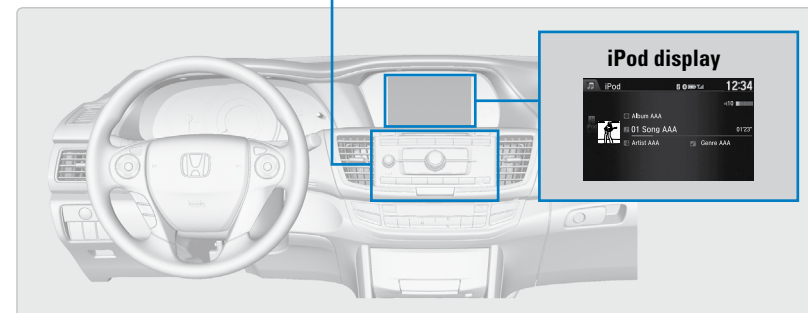
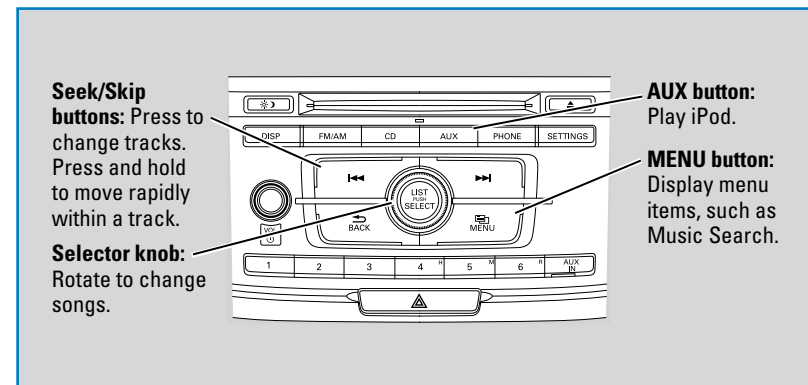

■ Searching for Music

Use the selector knob to search for tracks stored on the iPod.

1. From the audio screen, press the MENU button.
2. Select Music Search.
3. Select a search category.
4. Select the track you want to play.

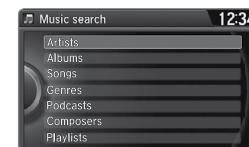

iPod is a trademark of Apple, Inc.

Models with one display

USB Flash Drive

Play and operate a USB flash drive through the vehicle's audio system. Only MP3, WMA, or AAC formats are supported. Connect your device to the USB port (see page 50).

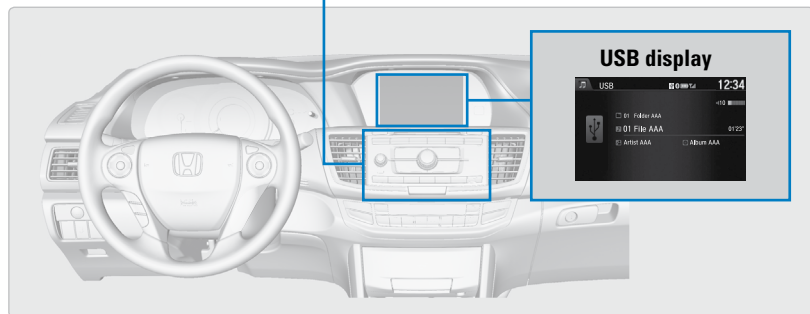
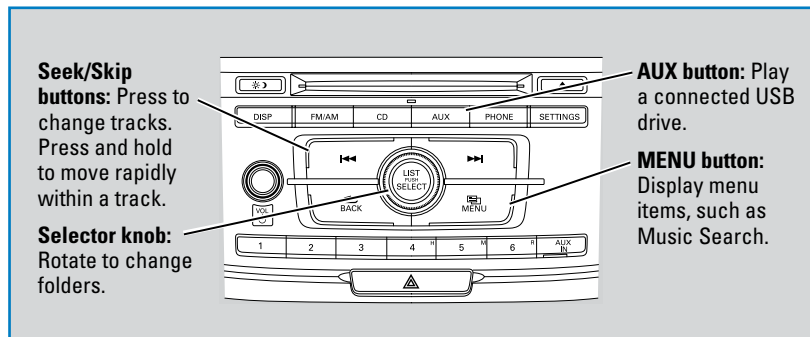

■ **Searching for Music**

Use the selector knob to search for tracks stored on the USB flash drive.

1. From the audio screen, press the MENU button.
2. Select Music Search.
3. Select a folder.
4. Select the track you want to play.



Models with one display

Bluetooth® Audio

Play streaming or stored audio from your compatible phone through the vehicle's audio system. Connect your phone to *Bluetooth* HandsFreeLink (see page 75). Visit *handsfreelink.com* (U.S.) or *handsfreelink.ca* (Canada) to check phone compatibility. Standard data rates apply.

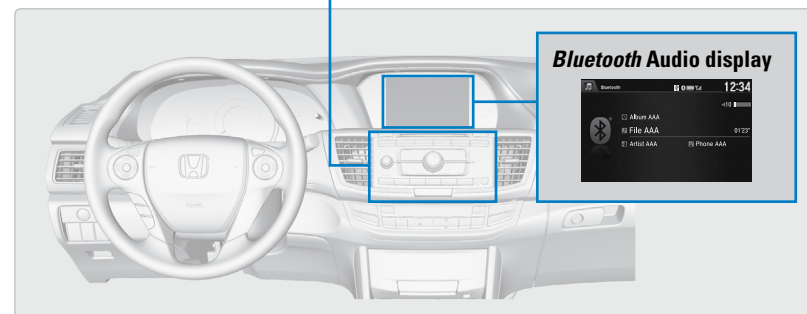
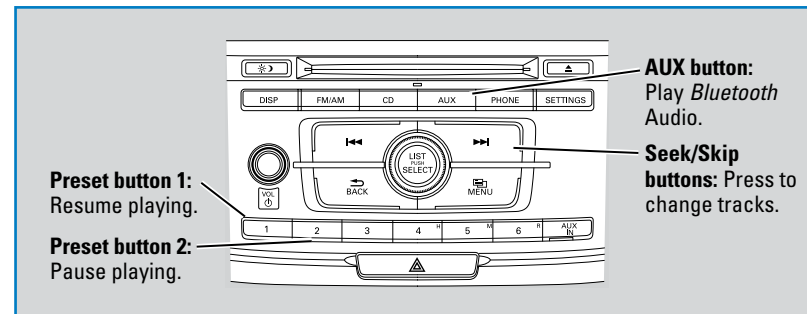

Notes:

- Make sure the volume on your phone is properly adjusted.
- You may need to enable additional settings on your phone for playback.
- The resume/pause function and remote audio controls are not supported on all phones.

Applicable laws may prohibit the operation of handheld electronic devices while operating a vehicle. Launch streaming audio on your phone only when safe to do so.

Models with one display

Pandora®*

Play and operate Pandora from your phone through the vehicle's audio system. Visit handsfreelink.com to check phone compatibility. Standard data rates apply.

Available in the U.S. only.

Connect your phone when the vehicle is stopped.

For iPhone:

- Connect via *Bluetooth* HandsFreeLink (see page 75) or USB port (see p. 50).
- A pop-up may appear on your phone requesting you to allow access for Pandora to be launched.
- If you cannot operate Pandora through the audio system, it may be streaming through *Bluetooth* Audio. Make sure Pandora is selected on the audio system.
- If Pandora still does not operate, try rebooting the phone and reconnecting the cable if necessary.

For Android or BlackBerry:

- Connect via *Bluetooth* HandsFreeLink (see page 75).

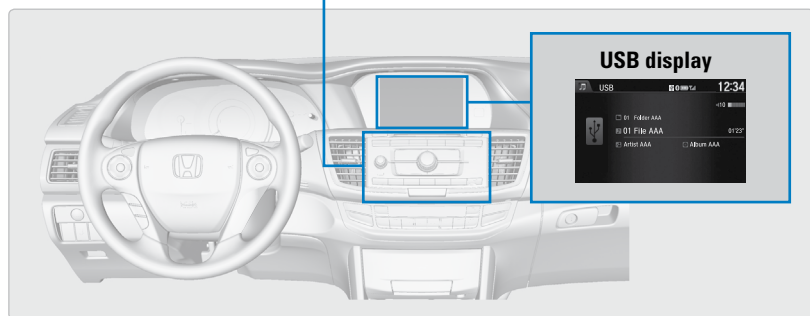
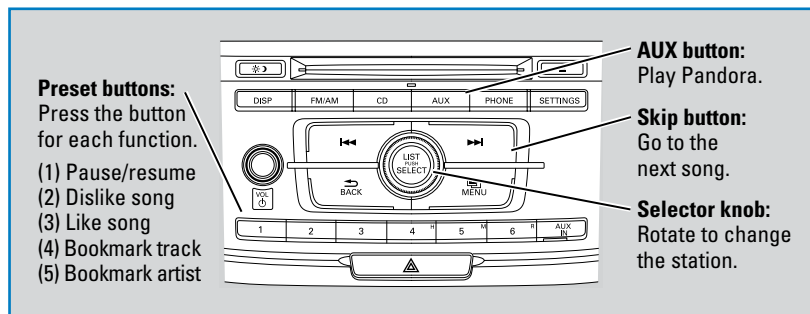

Applicable laws may prohibit the operation of handheld electronic devices while operating a vehicle. Launch streaming audio on your phone only when safe to do so.

Models with touchscreen

Touchscreen Operation

Use simple gestures—including touching, swiping, and scrolling—to operate certain audio functions.

Some items may be grayed out during driving to reduce the potential for distraction. You can select them when the vehicle is stopped or use voice commands* (see page 155).

Wearing gloves may limit or prevent touchscreen response.

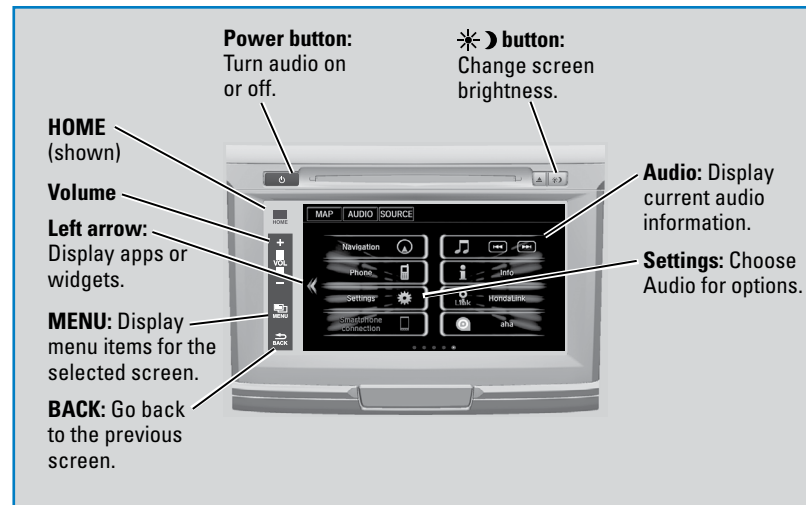

**if equipped*

■ Setting Touchscreen Sensitivity

You can adjust the touchscreen's sensitivity to your fingertip.

1. From the HOME screen, select Settings, then System.
2. Select Others, then Touch Panel Sensitivity.
3. Make your selection.

■ Changing Icon Order

You can change the order of the icons on the Home screen.

1. From the Home screen, select and hold an icon to enter the customization screen.
2. Select and hold the icon you want to move and slide it to a different position.
3. Select OK when complete.



■ Adding Apps or Widgets to the Home Screen

You can add apps or widgets to the Home screen for easy selection.

1. From the HOME screen, select the left arrow icon. Select and hold an empty space.
2. Select Add App or Add Widget. The Apps screen appears.
3. Select and hold the app or widget you want to add. The customization screen appears.
4. Select and hold the app or widget and move it to where you want. Hovering over either edge of the screen scrolls to the next page in that direction.
5. Select OK when complete.

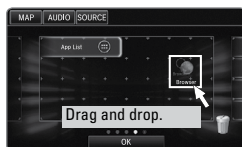
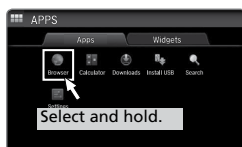
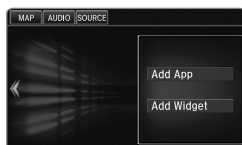

Models with touchscreen

HondaLink®

Provides you with useful information about your vehicle directly from Honda.

To check phone compatibility, visit handsfreelink.com (U.S.) or handsfreelink.ca (Canada). Standard data rates may apply with your phone service provider.

To get more information on HondaLink, visit www.hondalink.com (U.S.) or honda.ca/hondalink (Canada).

■ HondaLink Connection

Follow the steps below to connect to HondaLink and use its features.

1. Download the HondaLink Connect app to your compatible smartphone.
2. Pair your phone to *Bluetooth HandsFreeLink* (see page 81).
3. From the HOME screen, select HondaLink.
4. Certain features require you to send vehicle information to Honda. Select Enable Once, Always Enable, or Cancel.

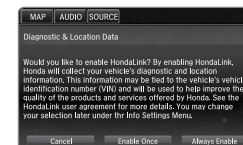

■ HondaLink Menu

Select a menu option.

Places*: Display restaurants, gas stations, and other locations. You can send a location to the navigation system and set a route.

Vehicle: Get instructional messages when your vehicle needs service.

Messages from Honda: Display helpful and important information from Honda.

Help & Support: Display tips for vehicle usage, get roadside assistance, or contact customer service.

Weather: Display a weekly five-day weather forecast for any zip code.



**if equipped*

Models with touchscreen

Wi-Fi Connection

You can connect the audio system to the internet using Wi-Fi and use online services through the touchscreen. If your compatible phone has hotspot capabilities, the system can be tethered to the phone. Follow the steps below to set up Wi-Fi when the vehicle is stopped. Standard data rates apply with your phone service provider.

1. From the HOME screen, select Settings.
2. Select Bluetooth/Wi-Fi. Select the Wi-Fi tab.
3. Select Wi-Fi On/Off Status, and select On.
4. Select Wi-Fi Network List. Make sure your phone's Wi-Fi setting is in access point (tethering) mode.
5. Select the phone you want to connect to the system. If the phone you want to connect does not appear, select Scan.
6. Select Connect.
7. Enter a password for your phone. Select Done.
The Wi-Fi symbol is displayed on the list when connection is successful.



Aha™ Radio

Access music and information programming, location-based services, and social media through your vehicle's audio system.

Visit handsfreelink.honda.com (U.S.) or handsfreelink.ca (Canada) to check phone compatibility. Standard data rates apply. Make sure you have an active Aha account.

Bluetooth connection

Connect your compatible smartphone via *Bluetooth* HandsFreeLink (see page 81). Make sure the HondaLink Connect app is downloaded to your phone (see page 63). Follow steps 1 and 2 below.

Wi-Fi connection

You can also connect via Wi-Fi (see page 64) or Wi-Fi tethering with your enabled smartphone. Follow steps 1 and 2 below.

1. From the HOME screen, select Aha (swipe to the second screen if necessary).
2. Enter your Aha account email and password to begin using Aha.

Models with touchscreen

Apple CarPlay™

Connect a compatible iPhone to the system. You can use the touchscreen to make a phone call, listen to music, and more. Visit the Apple CarPlay website for more information.

Park in a safe place before connecting your iPhone and launching any compatible apps.

1. Connect the iPhone to the front USB port (see p. 50).
2. From the HOME screen, select Apple CarPlay.
3. Apple CarPlay requires you to send vehicle information to Honda. Select Enable Once, Always Enable, or Cancel.
4. Select a menu option.

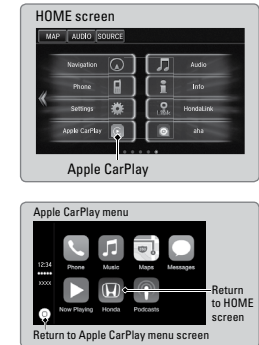

Phone: Access your contacts, make phone calls, or listen to voicemail. While connected to Apple CarPlay, calls can only be made through Apple CarPlay, not through *Bluetooth* HandsFreeLink.

Messages: View and reply to text messages, or have messages read to you aloud by the system.

Music: Play music stored on your iPhone.

Maps: View a map and operate navigation. You can only use Apple CarPlay or the pre-installed navigation system to set a destination with routing guidance.

Once connected, press and hold the Talk button to operate the system using voice commands with Siri Eyes Free.

Apple CarPlay requires a compatible iPhone with an active cellular connection and data plan. Your carrier's rate plans will apply.

Use of Apple CarPlay will result in the transmission of certain user and vehicle information (such as vehicle location, speed, and status) to your iPhone to enhance the Apple CarPlay experience. You will need to consent to the sharing of this information on the Display Audio screen.

Changes in operating systems, hardware, software, and other technology integral to providing Apple CarPlay functionality, as well as new or revised governmental regulations, may result in a decrease or cessation of Apple CarPlay functionality and services. Honda cannot and does not provide any warranty or guarantee of future Apple CarPlay performance or functionality.

It is possible to use third-party apps if they are compatible with Apple CarPlay. Refer to the Apple website for information on compatible apps.

Models with touchscreen

Android Auto™

Connect a compatible Android phone to the system. You can use the touchscreen to make a phone call, listen to music, and more. Visit the Android Auto website for more information.

Park in a safe place before connecting your Android phone and launching any compatible apps.

1. Download the Android Auto app to your phone.
2. Connect the phone to the front USB port (see p. 50). A tutorial appears.
3. From the HOME screen, select Android Auto.
4. Android Auto requires you to send vehicle information to Honda. Select Enable Once, Always Enable, or Cancel.
5. Select a menu option.

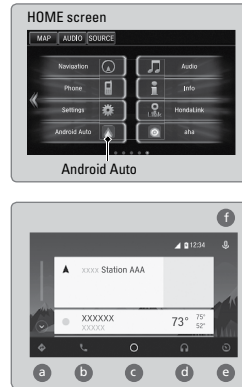

- a Maps/Navigation:** View a map and operate navigation. You can only use this system or the pre-installed navigation system to set a destination with routing guidance. You cannot enter destinations using the keyboard while the vehicle is moving.
- b Phone:** Make phone calls or listen to voicemail. While connected to Android Auto, calls can only be made through Android Auto, not through *Bluetooth HandsFreeLink*.
- c Google Now (Home):** Display useful information organized by Android Auto into simple cards that appear only when needed.
- d Music:** Play music from compatible apps. Select this icon to switch between music apps.
- e Return to HOME screen:** Go back to the vehicle system HOME screen.
- f Voice:** Use voice commands to operate Android Auto. You can also press and hold the Talk button on the steering wheel (see page 74) to say voice commands.

Android Auto requires a compatible Android phone with an active cellular connection and data plan. Your carrier's rate plans will apply.

Changes in operating systems, hardware, software, and other technology integral to providing Android Auto functionality, as well as new or revised governmental regulations, may result in a decrease or cessation of Android Auto functionality and services. Honda cannot and does not provide any warranty or guarantee of future Android Auto performance or functionality.

It is possible to use third-party apps if they are compatible with Android Auto. Refer to the Android Auto website for information on compatible apps.

Models with touchscreen

FM/AM Radio

Play FM or AM radio stations.

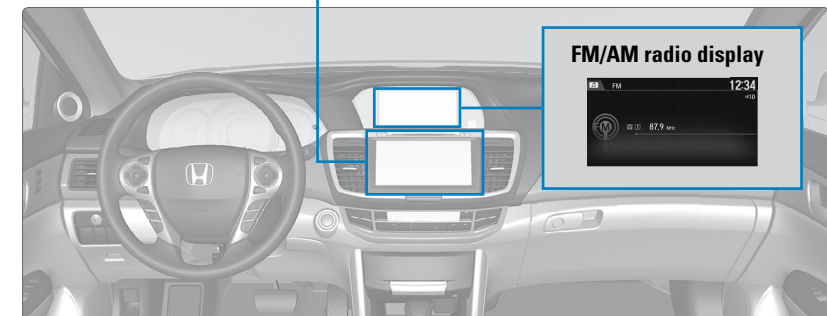
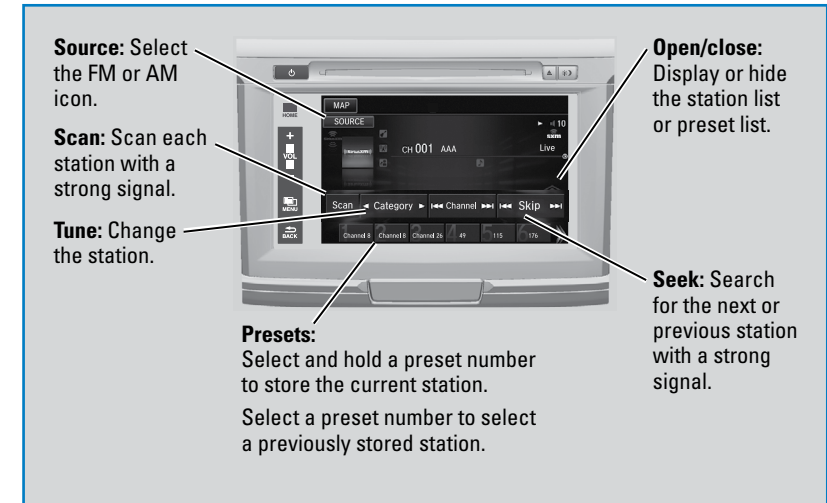

**if equipped*

Models with touchscreen

SiriusXM® Radio*

Available on a subscription basis only. For more information or to subscribe, contact your dealer, or visit www.siriusxm.com (U.S.) or www.sirius.ca (Canada).

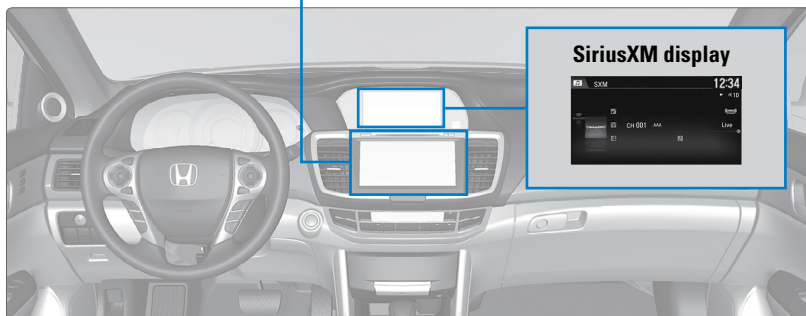
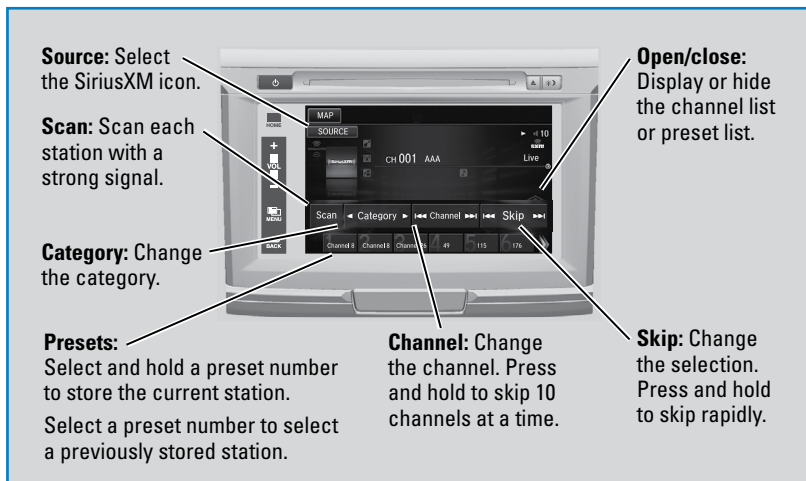

To learn about additional features—such as multi-channel preset, replay, or SportsFlash—see your Owner’s Manual on the Owner Information CD or visit owners.honda.com (U.S.) or myhonda.ca (Canada).

Available in the U.S. and Canada, except Hawaii, Alaska, and Puerto Rico.
 XM® is a registered trademark of Sirius XM Radio, Inc.
 *if equipped

Models with touchscreen

Compact Disc (CD)

The system supports audio CDs, CD-Rs, and CD-RWs in MP3, WMA, or AAC formats. Insert a CD to begin automatic playback.

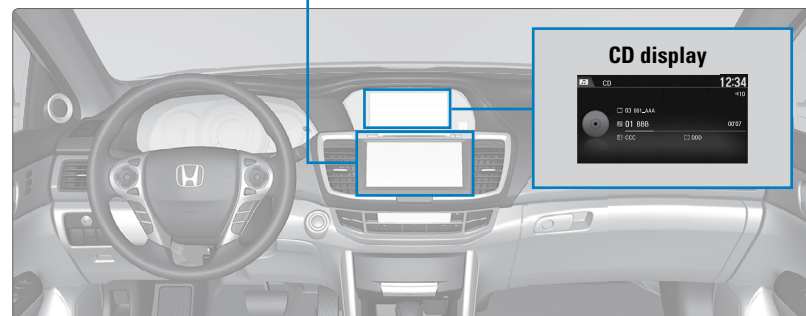
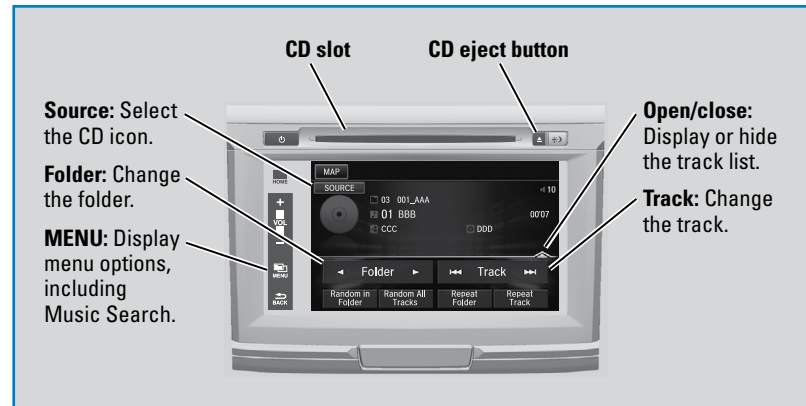

■ **Searching for Music**

Use the touchscreen to search for tracks stored on the CD.

1. From the audio screen, press MENU.
2. Select Music Search.
3. Select a folder.
4. Select the track you want to play.

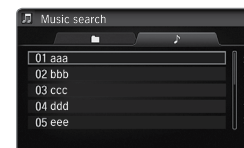

NOTICE

Do not use discs with adhesive labels or insert a damaged disc. Inserting these types of discs may cause them to get stuck or damage the audio unit.

Models with touchscreen

iPod®

Play and operate an iPod through the vehicle's audio system. Connect your device to the USB port (see p. 50).

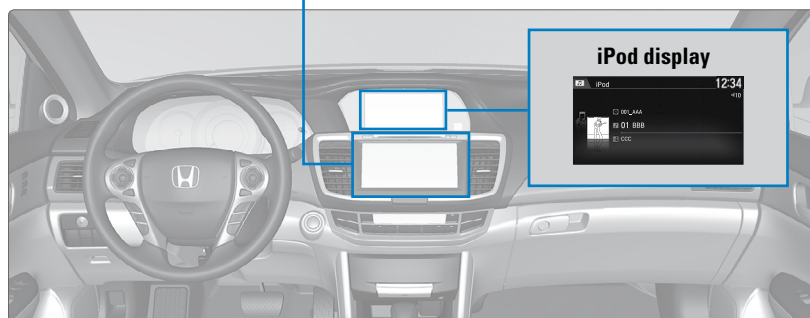
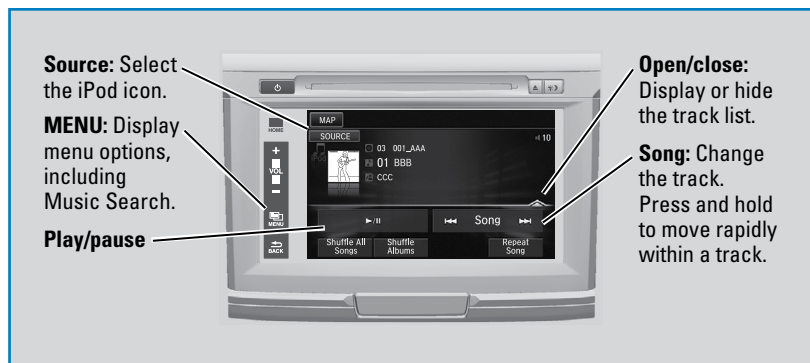

■ Searching for Music

Use the touchscreen to search for tracks stored on the iPod.

1. From the audio screen, press MENU.
2. Select Music Search.
3. Select a search option.
4. Select the track you want to play.

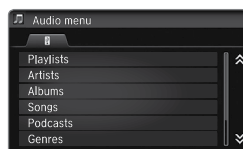

On vehicles with navigation, you can also search for and play iPod music using Song By Voice™ (see page 155).

iPod is a trademark of Apple, Inc.

Models with touchscreen

USB Flash Drive

Play and operate a USB flash drive through the vehicle's audio system. Only MP3, WMA, or AAC formats are supported. Connect your device to the USB port (see p. 50).

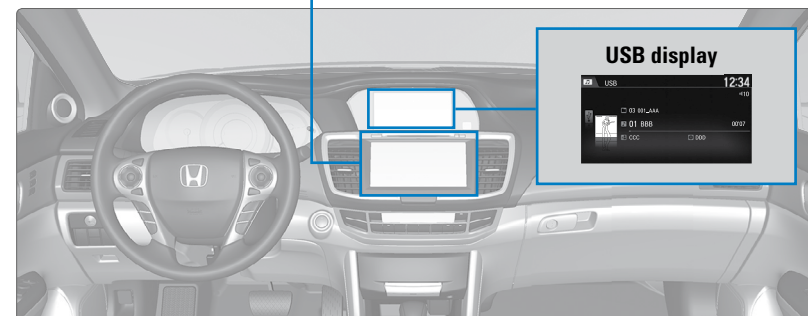
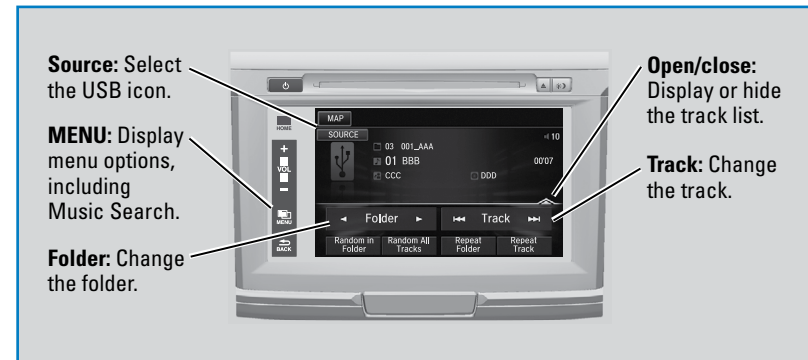

■ Searching for Music

Use the touchscreen to search for tracks stored on the USB flash drive.

1. From the audio screen, press MENU.
2. Select Music Search.
3. Select a folder.
4. Select the track you want to play.

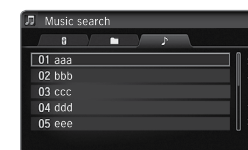

Models with touchscreen

Bluetooth® Audio

Play streaming or stored audio from your compatible phone through the vehicle's audio system. Visit handsfreelink.com (U.S.) or handsfreelink.ca (Canada) to check phone compatibility. Standard data rates apply with your phone service provider. Connect your phone to *Bluetooth* HandsFreeLink (see page 81).

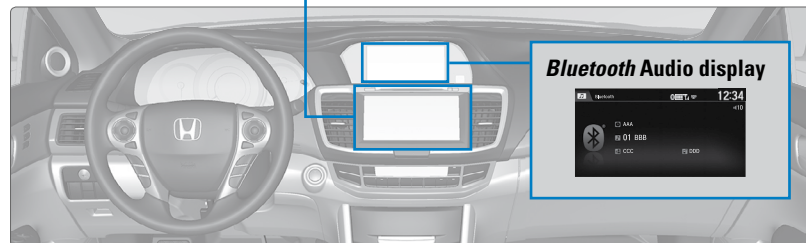
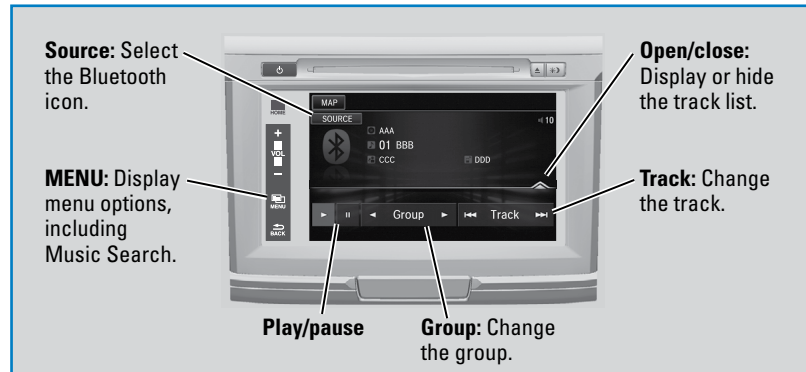
**■ Searching for Music**

Use the touchscreen to search for tracks stored on the device.

1. From the audio screen, press MENU.
2. Select Music Search.
3. Select a search category.
4. Select the track you want to play.

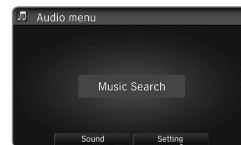
**Notes:**

- If a phone is currently connected via Apple CarPlay or Android Auto, *Bluetooth* Audio from that phone is unavailable.
- You may need to enable additional settings on your phone for playback.

Applicable laws may prohibit the operation of handheld electronic devices while operating a vehicle. Launch streaming audio on your phone only when safe to do so.

Models with touchscreen

Pandora®*

Play and operate Pandora from your compatible phone through the vehicle's audio system. Visit handsfreelink.com to check phone compatibility. Standard data rates apply with your phone service provider. **Available in the U.S. only.**

Connect your phone when the vehicle is stopped.

For iPhone:

- Connect via *Bluetooth* HandsFreeLink (see page 81) or USB port (see p. 50).
- A pop-up may appear on your phone requesting you to allow access for Pandora to be launched.
- If you cannot operate Pandora through the audio system, it may be streaming through *Bluetooth* Audio. Make sure Pandora is selected on the audio system.
- If a phone is connected via Apple CarPlay, Pandora can only be used within Apple CarPlay.
- If Pandora still does not operate, try rebooting the phone and reconnecting the cable if necessary.

For other compatible smartphones:

- Connect via *Bluetooth* HandsFreeLink (see page 81).

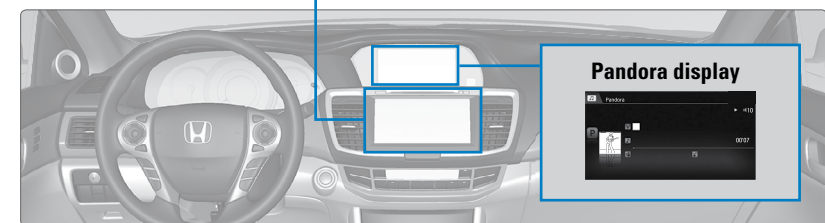
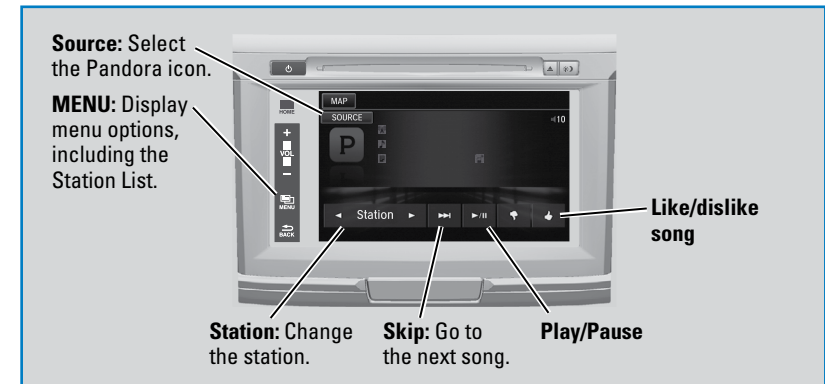

Applicable laws may prohibit the operation of handheld electronic devices while operating a vehicle. Launch streaming audio on your phone only when safe to do so.

BLUETOOTH® HANDSFREELINK® (HFL)

Learn how to operate the vehicle's hands-free calling system.

Models with one display

Basic HFL Operation

Make and receive phone calls using the vehicle's audio system, without handling your phone. Visit handsfreelink.com (U.S.) or handsfreelink.ca (Canada) to check phone compatibility.

To reduce the potential for driver distraction, certain manual functions may be inoperable or grayed out while the vehicle is moving. Stop or pull over to perform the function.

HFL Controls

Use the controls to enter information and make selections.

Pick-Up button: Answer an incoming call.

Hang-Up/Back button: End or decline a call, or cancel an operation.

Talk button: Make a call using a stored voice tag.

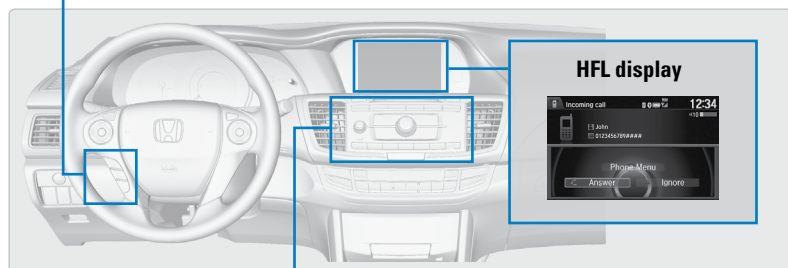

Selector knob: Rotate and press to make selections.

BACK button: Go back to the previous display.

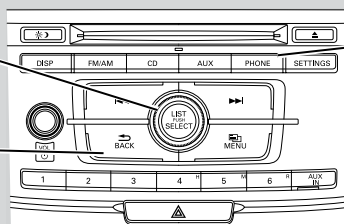

PHONE button: Display the phone screen.

Models with one display

Pairing a Phone

To use hands-free phone and streaming audio functions, you must first pair your phone to the system. This can only be done when the vehicle is stopped. Use the selector knob or interface dial to make and enter selections.

1. Press the SETTINGS button.
2. Select Phone Settings.
3. Select Bluetooth Device List (if no phone has been paired) or Connect Phone (if pairing an additional phone).
4. Select Add Bluetooth Device.
5. Make sure your phone is in discovery mode.
6. The system searches for your phone. Select your phone when it appears on the list.

If your phone does not appear:

Select Phone Not Found and search for HandsFreeLink from your phone.

7. The system gives you a pairing code. Compare it to the code that appears on your phone, and connect when prompted.
8. The system asks if you want to enable Automatic Phone Sync, which imports your phone's call history and phonebook. Select On.
9. Press the BACK button to exit the menu.



Applicable laws may prohibit the operation of handheld electronic devices while operating a vehicle.

Models with one display

Making a Call

You can make a call using several methods.

Dialing a Number

Enter a 10-digit phone number to call.

Using voice commands

Press the Talk button before you say each command.

1. Say "Dial by number."
2. Say the phone number. For example, "3-1-0-5-5-1-2-3-4."
3. The system begins to dial.

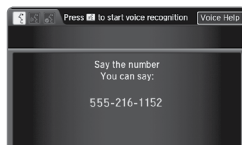

Using the menu

Use the selector knob or interface dial to make and enter selections. This method is inoperable while the vehicle is moving.

1. Press the PHONE button.
2. Press the MENU button.
3. Select Dial.
4. Enter the phone number. Select the green phone icon to call.



Storing Speed Dial Entries

Store up to 20 numbers for quick dialing. Use the selector knob or interface dial to make and enter selections.

1. Press the PHONE button.
2. Press the MENU button.
3. Select Speed Dial, then select New Entry.
4. Select an entry method.
5. If desired, you can create a voice tag for the number. Follow the prompts.



When a voice tag is created, you can press the Talk button and say "Call" and the stored voice tag to quickly call the number.

Using Speed Dial and Call History

Make calls quickly using stored speed dial entries or call history numbers.

Using voice commands

Press the Talk button before you say each command.

1. Say "Dial by voice tag."
2. Say the stored voice tag name. For example, "John Smith."



Using the menu

1. Press the PHONE button.
2. Press the MENU button.
3. Select Speed Dial or Call History.
4. Scroll through the list to find the entry you want to call, and select it to call.



Using the Phonebook

When your phone is paired, its entire phonebook can be automatically imported to the system. Automatic Phone Sync must be turned on.

Using voice commands

Press the Talk button before you say each command.

1. Say "Dial by name."
2. Say the phonebook name and phone type. For example, "John Smith mobile."



Using the menu

Use the selector knob or interface dial to make and enter selections. This method is inoperable while the vehicle is moving.

1. Press the PHONE button.
2. Press the MENU button.
3. Select Phonebook.
4. Scroll through the list to find the name and number you want to call, and select it to call.



Models with one display

SMS Text Messaging

Certain phones can receive and send messages while paired and connected. Visit handsfreelink.com (U.S.) or handsfreelink.ca (Canada) to check phone compatibility. Standard message rates apply. This feature is limited while the vehicle is moving.

■ **Receiving and Responding to Messages**

When you receive a new message, a pop-up appears on the display. Use the selector knob to view the message when the vehicle is stopped. You can also reply to it using fixed phrases or call the sender.

1. When the prompt appears, select Read.
2. The message is displayed, and the system reads it aloud.

To reply: With the message open, press the selector knob to enter the Text Message Menu. Select Reply, and choose one of the six available responses. Select Send to send the message. You cannot create a new text message.

To call the sender: With the message open, press the selector knob to enter the Text Message Menu. Select Call.

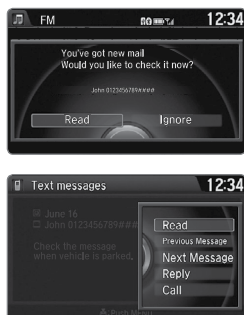

Models with touchscreen

Basic HFL Operation

Make and receive phone calls using the vehicle's audio system, without handling your phone. Visit handsfreelink.com (U.S.) or handsfreelink.ca (Canada) to check phone compatibility.

If your iPhone is connected to Apple CarPlay or Android Auto, calls can only be made through Apple CarPlay or Android Auto, not through *Bluetooth* HandsFreeLink.

To reduce the potential for driver distraction, certain manual functions may be inoperable or grayed out while the vehicle is moving. Stop or pull over to perform the function. Voice commands are also available.

■ **HFL Controls**

Use the controls to enter information and make selections.

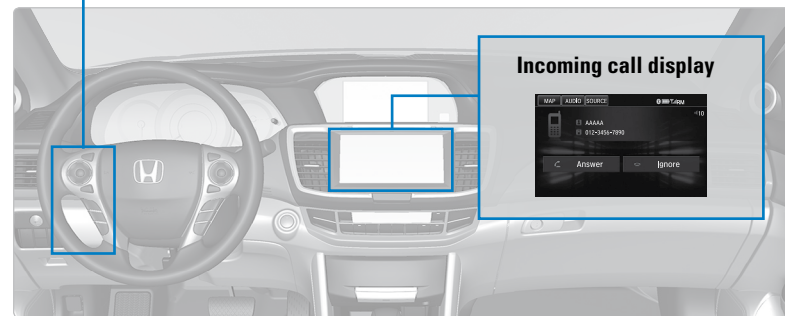
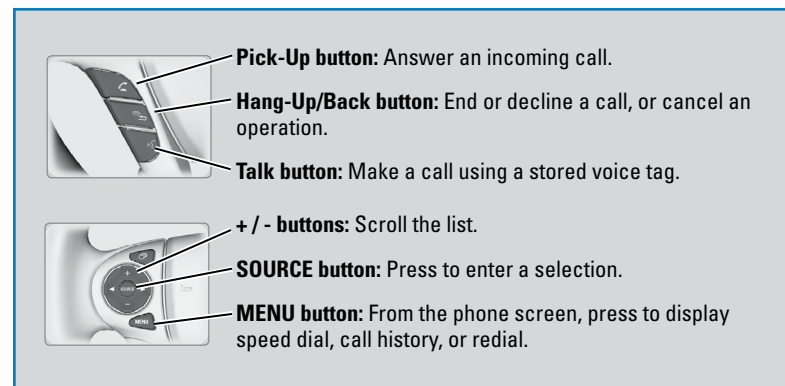
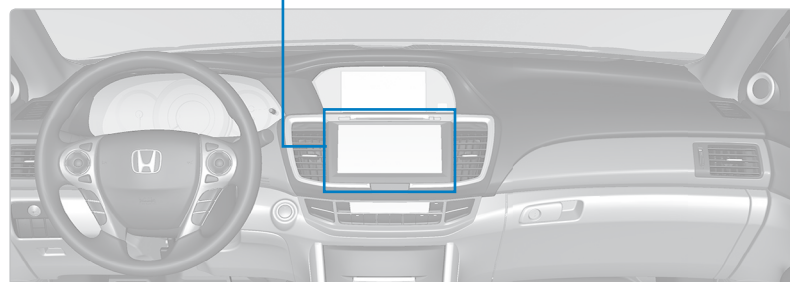
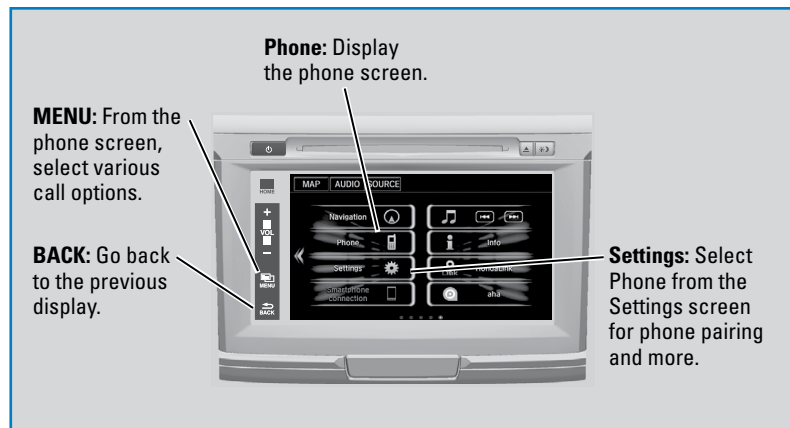

TABLE OF CONTENTS
VISUAL INDEX
SAFETY INFORMATION
INSTRUMENT PANEL
VEHICLE CONTROLS
AUDIO AND CONNECTIVITY
BLUETOOTH® HANDSFREELINK®
HONDALINK®

NAVIGATION
DRIVING
HANDLING THE UNEXPECTED
MAINTENANCE
SPECIFICATIONS
CUSTOMER INFORMATION
VOICE COMMAND INDEX
INDEX



Talk Button Tips

- When using the Talk button, wait for a beep before saying a command.
- To bypass the system prompts, simply press the Talk button again to say your command.
- When the Talk button is pressed, all available voice commands are highlighted in yellow.
- The system recognizes only those commands in the Voice Command Index (see page 154).
- Speak in a clear, natural voice.
- Reduce all background noise.
- Close the windows and moonroof.

Models with touchscreen

Pairing a Phone

To use hands-free phone and streaming audio functions, you must first pair your phone to the system. This can only be done when the vehicle is stopped. Use the touchscreen to make and enter selections.

If there is an active connection to Apple CarPlay (see page 65) or Android Auto (see page 66), pairing of additional Bluetooth-compatible devices is unavailable and Add Bluetooth Device is grayed out from the Bluetooth Device List screen.

1. From the HOME screen, select Settings.
2. Select Phone.
3. Select Bluetooth Device List
4. Select Add Bluetooth Device.
5. Make sure your phone is in discovery mode. Select OK.
6. The system searches for your phone. Select your phone when it appears on the list.
If your phone does not appear: Select Phone Not Found and search for HandsFreeLink from your phone.
7. The system gives you a pairing code. Compare it to the code that appears on your phone, and connect when prompted.
8. The system asks if you want to enable options:
HondaLink Assist: Select On to enable emergency collision notification (see page 85).
Automatic Phone Sync: Select On to automatically import contacts and call history from your phone.
9. Press BACK to exit the menu.

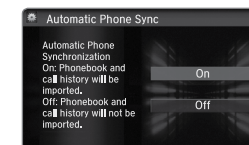

Applicable laws may prohibit the operation of handheld electronic devices while operating a vehicle.

Models with touchscreen

Making a Call

You can make a call using several methods.

■ Dialing a Number

Enter a 10-digit phone number to call.

Using voice commands

Press the Talk button before you say each command.

1. Say "Call by number."
2. Say the phone number. For example, "3-1-0-5-5-5-1-2-3-4."
3. The system begins to dial.



Using the touchscreen

Manual operation is limited while the vehicle is moving. Voice commands are always available.

1. From the HOME screen, select Phone.
2. Select MENU.
3. Select Dial.
4. Enter the phone number. Select the green phone icon to call.



■ Storing Speed Dial Entries

Store up to 20 numbers for quick dialing.

1. From the HOME screen, select Phone.
2. Select MENU.
3. Select Speed Dial, then select New Entry.
4. Select an entry method.
5. If desired, you can create a voice tag for the number. Follow the prompts.



■ Using Speed Dial and Call History

Make calls quickly using stored speed dial entries or call history numbers.

Using voice commands

Press the Talk button before you say each command.

1. Say "Dial by name."
2. Say the stored voice tag name. For example, "John Smith."

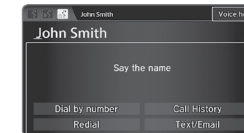

Using the touchscreen

1. From the Home screen, select Phone.
2. Scroll through the list to find the entry you want to call, and select it to call.



■ Using the Phonebook

When your phone is paired, its entire phonebook can be automatically imported to the system. Automatic Phone Sync must be turned on.

Using voice commands

Press the Talk button before you say each command.

1. Say "Call by name."
2. Say the phonebook name and phone type. For example, "John Smith mobile."



Using the touchscreen

Manual operation is limited while the vehicle is moving. Voice commands are always available.

1. From the HOME screen, select Phone.
2. Select MENU.
3. Select Phonebook.
4. Scroll through the list to find the name and number you want to call, and select it to call.

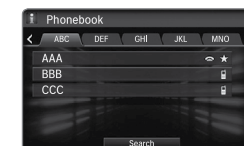

Models with touchscreen

SMS Text Messaging and E-Mail*

Certain phones can receive and send messages while paired and connected. Visit handsfreelink.honda.com (U.S.) or www.handsfreelink.ca (Canada) to check phone compatibility. Standard message rates apply. This feature is limited while the vehicle is moving.

■ Receiving and Responding to Messages

When you receive a new message, a pop-up appears on the touchscreen. You can view the message when the vehicle is stopped. You can also reply to it using fixed phrases or call the sender.

1. When the prompt appears, select Read.
2. The message is displayed, and the system reads it aloud.

To reply: With the message open, select Reply, and choose one of the six available responses. Select Send to send the message. You cannot create a new text message.

To call the sender: With the message open, select Call.

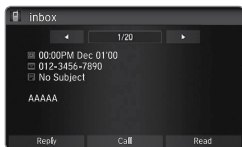

■ Selecting an Account

If your phone has both text message and e-mail accounts, you can select only one of them at a time to be active and receive notifications.

1. From the HOME screen, select Settings.
2. Select Phone.
3. Select Select Account.
4. Select Text Message or an e-mail account.



*if equipped

Models with touchscreen

HondaLink® Assist

Automatically attempts to connect and talk to an operator who can locate your vehicle and send emergency help in the event of a collision. Visit www.hondalink.com (U.S.) or honda.ca/hondalinkassist (Canada) for more information.

1. Make sure your phone is on and paired to Bluetooth HandsFreeLink (see page 81).
2. Select Call Now, or the system automatically connects after 10 seconds. The vehicle information and its position are sent to the operator.
3. Select Talk Now to immediately talk to the operator.
4. When the call is complete, select Hang Up or press the Hang Up/Back button on the steering wheel.

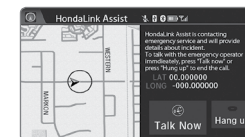
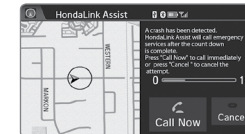

For vehicles equipped with HondaLink Assist, owner activation constitutes authorization for Honda to collect information from your vehicle needed to provide the service, and agreement to the Terms of Use at www.hondalink.com/TermsAndConditions. In a crash, HondaLink Assist will attempt to notify emergency services but NEITHER Honda NOR ITS SERVICE PROVIDERS GUARANTEE THAT SUCH NOTIFICATION WILL OCCUR.

TABLE OF CONTENTS
VISUAL INDEX
SAFETY INFORMATION
INSTRUMENT PANEL
VEHICLE CONTROLS
AUDIO AND CONNECTIVITY
BLUETOOTH® HANDSFREELINK®
HONDALINK®

NAVIGATION
DRIVING
HANDLING THE UNEXPECTED
MAINTENANCE
SPECIFICATIONS
CUSTOMER INFORMATION
VOICE COMMAND INDEX
INDEX

Models with touchscreen

Siri™ Eyes Free

Activate Siri through your vehicle when an iPhone is paired to the system. Visit handsfreelink.honda.com (U.S.) or honda.ca/siri (Canada) to check phone compatibility.

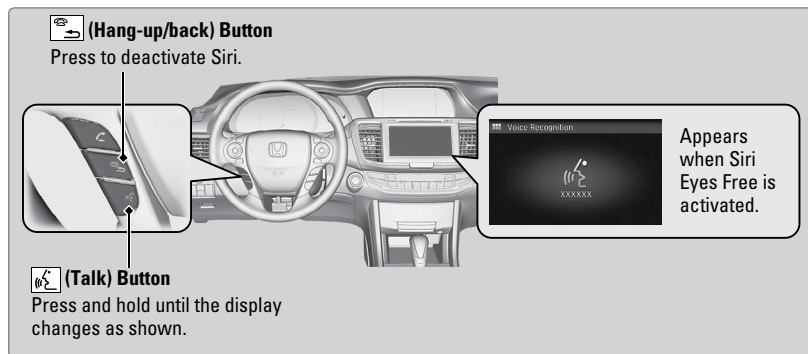

Here are some examples of Siri commands:

- | | |
|----------------------------------|------------------------------------|
| "Call John Smith" | "Remind me to pick up dinner" |
| "Read my new text message" | "Set up a meeting today at 3 p.m." |
| "Find a nearby sushi restaurant" | "Play song XYZ" |

Notes:

- Any requests that include visual feedback from Siri on your phone are not displayed in the vehicle.
- Certain commands rely on the iPhone's features and existing apps.
- To hear turn-by-turn directions or songs through the vehicle, set the audio source to *Bluetooth Audio*.

Siri and iPhone are trademarks of Apple, Inc.

NAVIGATION*

Learn how to enter a destination and operate the navigation system.

Basic Navigation Operation

A real-time navigation system uses GPS and a map database to show your current location and help guide you to a desired destination. You can operate the system using voice commands or the touchscreen.

To reduce the potential for driver distraction, certain manual functions may be inoperable or grayed out while the vehicle is moving. Voice commands are always available.

Steering Wheel Controls

Use the steering wheel controls to control the system.

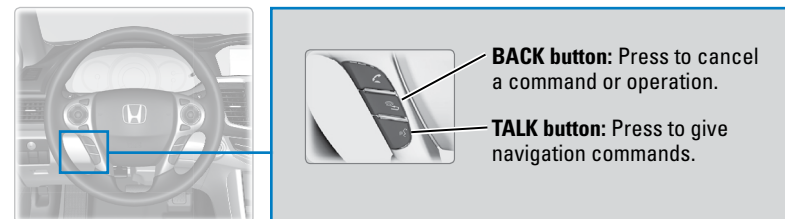

Talk Button Tips

- When using the Talk button, wait for a beep before saying a command.
- To bypass the system prompts, simply press the Talk button again to say your command.
- The system recognizes only those commands in the Voice Command Index (see page 154).
- Speak in a clear, natural voice.
- Reduce all background noise.
- Close the windows and moonroof.

System Guidance Volume

Adjust the navigation system volume.

1. From the HOME screen, select Settings.
2. Select System.
3. Select the Sound/Beep tab.
4. Select Guidance Volume, and adjust the level. Select OK when complete.
5. Press BACK to exit the menus.

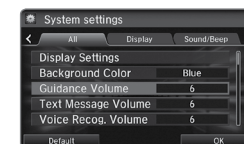

**if equipped*

TABLE OF CONTENTS
VISUAL INDEX
SAFETY INFORMATION
INSTRUMENT PANEL
VEHICLE CONTROLS
AUDIO AND CONNECTIVITY
BLUETOOTH® HANDSFREELINK®
HONDALINK®

NAVIGATION
DRIVING
HANDLING THE UNEXPECTED
MAINTENANCE
SPECIFICATIONS
CUSTOMER INFORMATION
VOICE COMMAND INDEX
INDEX

Navigation Display and Controls

Touch icons on the screen to enter information and make selections.

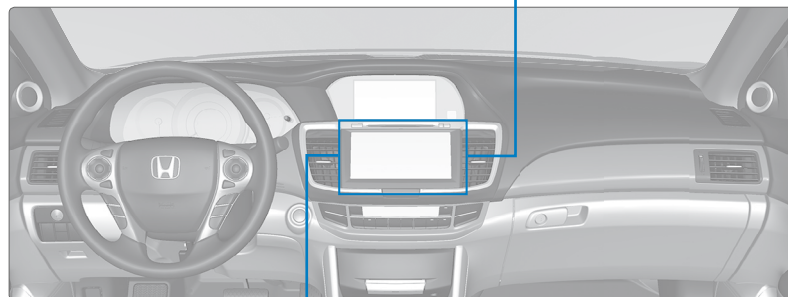
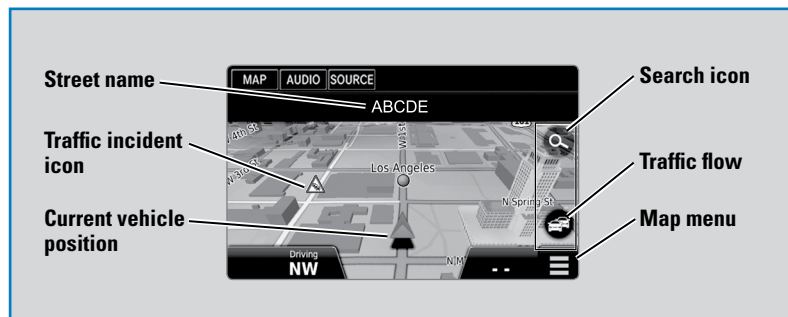

⚠ WARNING

Using the navigation system while driving can take your attention away from the road, causing a crash in which you could be seriously injured or killed. Operate system controls only when the conditions permit you to safely do so.

Entering a Destination

Use several methods to enter a destination.

Home Address

Store your home address in the system so you can easily route to it.

1. From the map screen, select the Search icon.
2. Select MENU.
3. Select Set Home Location.
4. Select Enter My Address.
5. Select Search All.
6. Enter the street number and select Done.
7. Enter the street name and select Done. Select the street from the list.
8. Select the address from the list. A map of the address is shown. Select Select.



When your home address is stored, you can press the Talk button and say "Navigation" and then "Go home" at any time. You can also select Go Home from the Where To? menu.

Street Address

Enter a street address.

1. From the map screen, select the Search icon.
2. Select Address.
3. Select Search All.
4. Enter the street number and select Done.
5. Enter the street name and select Done. Select the street from the list.
6. Select the address from the list.
7. Select Go!.

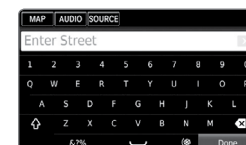

You can also enter a street address using voice commands. Press the Talk button and say "Navigation" and then "Find Address." Follow the prompts.

Place Category

Enter a destination using a point of interest or landmark.

1. From the map screen, press MENU.
2. Select Where To?.
3. Select Categories.
4. Select a category (and a subcategory if necessary).
5. Select a place from the list.
6. Select Go!.

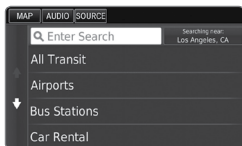
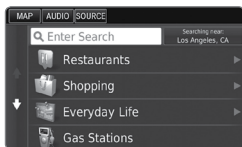

You can also enter a street address using voice commands. Press the Talk button and say "Navigation" and then "Find Place." Follow the prompts.

Recent Places

Select an address from a list of your 50 most recent destinations.

1. From the map screen, press MENU.
2. Select Where To?.
3. Select Recent.
4. Select a place from the list.
5. Select Go!.

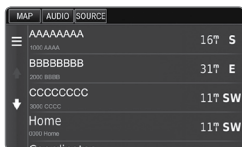

Saved Places

Save locations so you can quickly route to them.

- Saving a location**
1. From the map screen, press MENU.
 2. Select Where To?.
 3. Select Enter Search.
 4. Enter the address or place name.
 5. Select the destination name when it appears on the map screen.
 6. Select the menu icon.
 7. Select Save.
 8. Select OK.

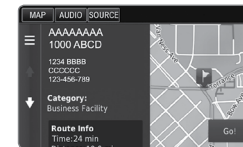

You can also save your current location. From the map screen, select the vehicle icon. Select Save. Enter a name for the location. Select Done. Select OK.

Routing to a saved location

1. From the map screen, press MENU.
2. Select Where To?.
3. Select Saved.
4. Select the destination from the list.
5. Select Go!.

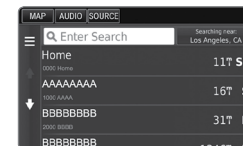

Routing

After a destination is set, you can alter or cancel your route.

Map Legend

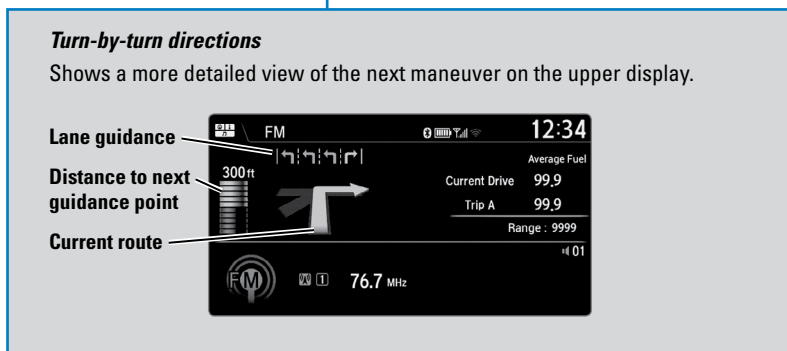
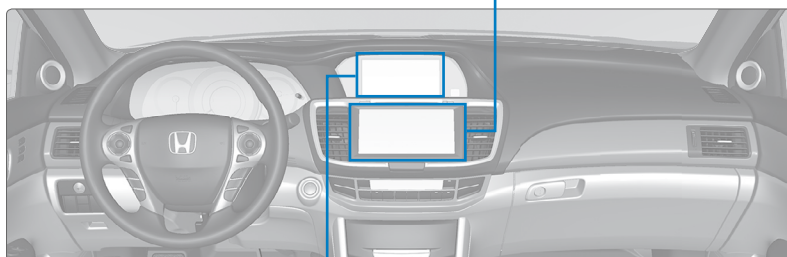
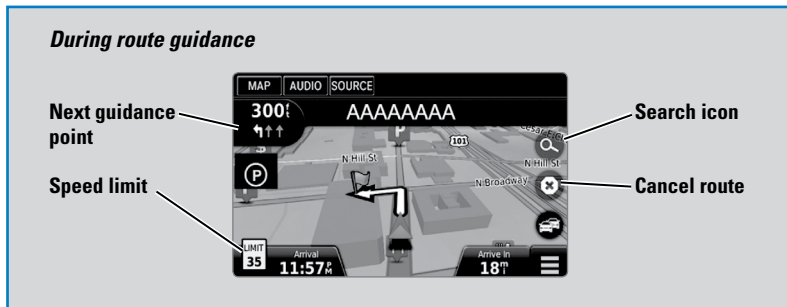

Traffic

View traffic flow and incidents in major metro areas. You can also select traffic to avoid. Traffic coverage is limited in Canada.

Viewing traffic

1. From the map screen, select the traffic icon.
2. Select Traffic Conditions.
3. Traffic icons are shown on the map. Select the magnifying glass icon to display a full list of traffic delays.



Avoiding traffic on your route

1. From the map screen, select the traffic icon.
2. Select Traffic on Route.
3. Select an incident to avoid from the list.
4. Select the menu icon.
5. Select Avoid.

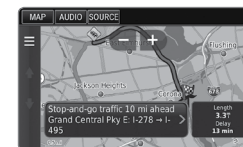
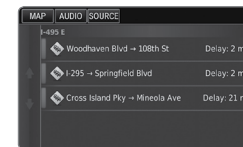

DRIVING

Learn about preparation for driving, as well as other features.

Before Driving

Check the following items before you begin driving.

■ Exterior Checks

- Make sure there are no obstructions on the windows, door mirrors, exterior lights, or other parts of the vehicle.
- Remove any frost, snow, or ice.
- Make sure the hood is securely closed.
- Heat from the engine and exhaust can ignite flammable materials left under the hood, causing a fire. If you've parked your vehicle for an extended period, inspect and remove any debris that may have collected, such as dried grass and leaves that have fallen or have been carried in for use as a nest by a small animal. Also check under the hood for leftover flammable materials after you or someone else has performed maintenance on your vehicle.
- Make sure the tires are in good condition.
- Make sure there are no people or objects behind or around the vehicle.

NOTICE

If the doors are frozen shut, use warm water around the door edges to melt any ice. Do not try to force them open, as this can damage the rubber trim around the doors. When done, wipe dry to avoid further freezing.

■ Interior Checks

- Store or secure all items on board properly.
- Do not pile items higher in the cargo area than the seat-back height.
- Do not place anything in the front seat footwells. Make sure to secure the floor mats.
- If you have any animals on board, do not let them move freely around in the vehicle.
- Securely close and lock all doors and the trunk.
- Adjust your seating position, mirrors, and steering wheel properly.
- Make sure items placed on the floor behind the front seats cannot roll under the seats.
- Everyone in the vehicle must fasten their seat belt.
- Make sure that the indicators in the instrument panel come on when you start the vehicle, and go off soon after.

In addition:

- During the first 600 miles (1,000 km) of operation, avoid sudden acceleration or full throttle operation so as not to damage the engine or powertrain.
- Avoid hard braking for the first 200 miles (300 km). You should also follow this when the brake pads are replaced.

WARNING

Improper accessories or modifications can affect your vehicle's handling, and stability, and performance, and cause a crash in which you can be seriously hurt or killed.

Follow all instructions in the vehicle owner's manual regarding accessories and modifications.

Maximum Load Limit

Carrying too much cargo or improperly storing it can affect your vehicle's handling, stability, stopping distance, and tires, and make it unsafe.

The maximum load for your vehicle is 850 lbs (385 kg). See the Tire and Loading Information label on the driver's doorjamb.

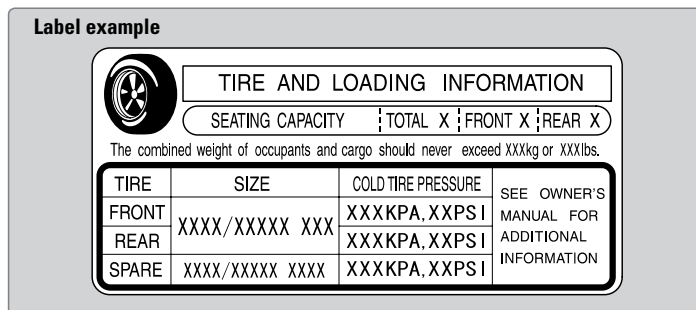

This figure includes the total weight of all occupants, cargo, and accessories, and the tongue load if you are towing a trailer. Below are the steps for determining the correct load limit:

1. Locate the statement "The combined weight of occupants and cargo should never exceed XXX kg or XXX lbs." on your vehicle's placard.
2. Determine the combined weight of the driver and passengers that will be riding in your vehicle.
3. Subtract the combined weight of the driver and passengers from XXX kg or XXX lbs.
4. The resulting figure equals the available amount of cargo and luggage load capacity. For example, if the "XXX" amount equals 1,400 lbs. and there will be five 150 lb. passengers in your vehicle, the amount of available cargo and luggage load capacity is 650 lbs. (1,400 - 750 (5 x 150) = 650 lbs.)
5. Determine the combined weight of luggage and cargo being loaded on the vehicle. That weight may not safely exceed the available cargo and luggage load capacity calculated in step 4.
6. If your vehicle will be towing a trailer, load from your trailer will be transferred to your vehicle. Consult the Owner's Manual on the Owner Information CD or at owners.honda.com (U.S.) or myhonda.ca (Canada) to determine how this reduces the available cargo and luggage load capacity of your vehicle.

In addition, the total weight of the vehicle, all occupants, accessories, cargo, and trailer tongue load must not exceed the Gross Vehicle Weight Rating (GVWR) or the Gross Axle Weight Rating (GAWR). Both are on a label on the driver's doorjamb.

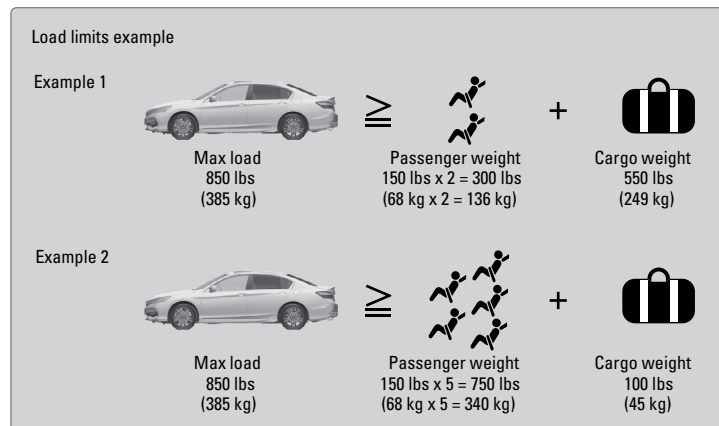

WARNING

Overloading or improper loading can affect handling and stability and cause a crash in which you can be hurt or killed.

Follow all load limits and other loading guidelines in this guide.

The headlight aim on your vehicle was set by the factory, and does not need to be adjusted. However, if you regularly carry heavy items in the trunk or tow a trailer, have the aiming readjusted at your dealer or by a qualified technician.

Towing a Trailer

Your vehicle can tow a trailer if you carefully observe the load limits, use the proper equipment, and follow the towing guidelines. See the Owner's Manual on the Owner Information CD or visit owners.acura.com (U.S.) or myacura.com (Canada) for more information.

■ Total Trailer Weight

Maximum allowable weight of the trailer, cargo, and everything in or on it must not exceed 1,000 lbs (450 kg). Towing loads in excess of this can seriously affect vehicle handling and performance and can damage the engine and drivetrain.

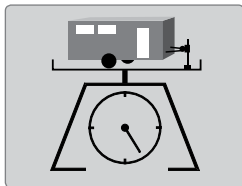

■ Tongue Load

The weight of the tongue with a fully loaded trailer on the hitch should be approximately 10% of the total trailer weight.

- Excessive tongue load reduces front tire traction and steering control. Too little tongue load can make the trailer unstable and cause it to sway.
- To achieve a proper tongue load, start by loading 60% of the load toward the front of the trailer and 40% toward the rear. Readjust the load as needed.

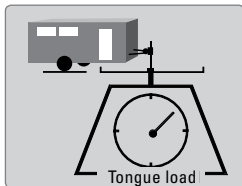

■ Pre-tow Checklist

When preparing to tow, and before driving away, ensure the following:

- The vehicle has been properly serviced, and the suspension and the cooling system are in good operating condition.
- Avoid towing a trailer during your vehicle's first 600 miles (1,000 km).
- The trailer has been properly serviced and is in good condition.
- All weights and loads are within limits. Never exceed the gross weight ratings.
- Check if all loads are within limits at a public scale. If a public scale is not available, add the estimated weight of your cargo load to the weight of your trailer (as quoted by the manufacturer) and the tongue load.
- The hitch, safety chains, and any other attachments are secure.
- All items in or on the trailer are properly secured and cannot shift while you drive.
- Trailer lights and brakes work properly.
- Trailer tire pressures (including spare tire) are correct.

⚠ WARNING

Exceeding any load limit or improperly loading your vehicle and trailer can cause a crash in which you can be seriously hurt or killed.

Check the loading of your vehicle and trailer carefully before starting to drive.

Remote Engine Start*

Start your vehicle's engine using the remote transmitter before you enter the vehicle.

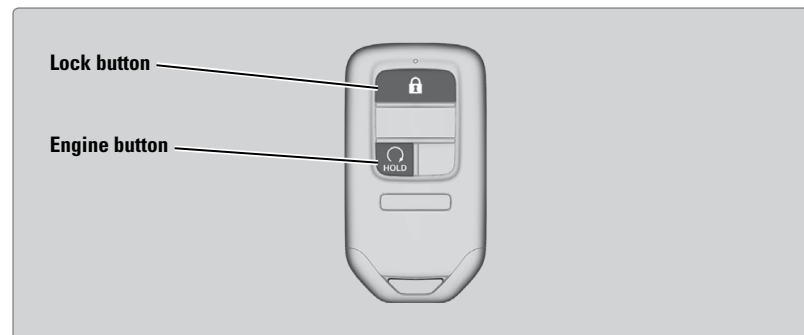

Make sure the vehicle is in a safe location when using remote engine start (i.e., a well-ventilated area, away from any flammable materials).

■ Starting the Engine

Press the Lock button, then press and hold the Engine button within 5 seconds to remotely start the engine.

The engine runs for up to 10 minutes. To extend the run time for another 10 minutes, repeat the procedure during the initial 10 minutes.

While the engine is running, the climate control system adjusts the cabin temperature, the security system remains on, and lights and accessories remain off.

■ Stopping the Engine

Press and hold the Engine button.

The engine will also stop if it has been running for more than 10 minutes, or if any door is opened without using the remote or smart entry.

⚠ WARNING

Engine exhaust contains toxic carbon monoxide gas.

Breathing carbon monoxide can kill you or cause unconsciousness.

Never use the remote engine starter when the vehicle is parked in a garage or other area with limited ventilation.

*if equipped

Starting to Drive

Turn on the vehicle and start the engine to begin driving.

Before Starting the Engine

Continuously Variable Transmission (CVT)

Check that the shift lever is in Park (P), then press the brake pedal. Keep your foot firmly on the brake pedal when starting the engine.

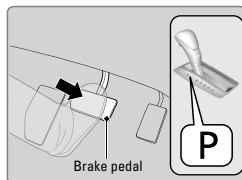

Manual transmission

Check that the shift lever is in Neutral (N), then press the brake pedal with your right foot and the clutch pedal with your left foot. The clutch must be fully pressed to start the engine.

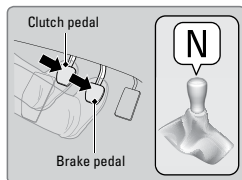

The engine is harder to start in cold weather and in thinner air found at altitudes above 8,000 feet (2,400 m). When starting the engine in cold weather, turn off all electrical accessories such as the lights, climate control system, and rear defogger in order to reduce battery drain.

Starting the Ignition*

Insert the key into the ignition and turn to turn on the vehicle or start the engine.

LOCK: Insert and remove the key in this position.

ACCESSORY: Operate the audio system and other accessories in this position.

ON: Operate other electrical items, such as wipers and power windows. This is also the position when driving.

START: This position is for starting the engine. The switch returns to ON when you release the key.

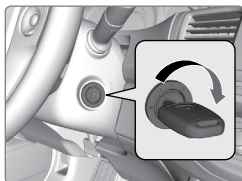

Manual transmission models

WARNING

Removing the key from the ignition switch while driving locks the steering. This can cause you to lose control of the vehicle.

Remove the key from the ignition switch only when parked.

*if equipped

Changing the Power Mode*

Use the ENGINE START/STOP button to cycle through power modes or start the engine.

Accessory or On mode: Press the ENGINE START/STOP button once without pressing the brake pedal for Accessory mode. Press it again for On mode.

Starting the engine: Press and hold the brake pedal or clutch, then press the ENGINE START/STOP button. Keep your foot firmly on the brake pedal when starting the engine.

Turning the vehicle off: Shift to Park (P) or apply the parking brake, then press the ENGINE START/STOP button. If you press the button and the shift lever is not in Park (P), the vehicle goes into Accessory mode.

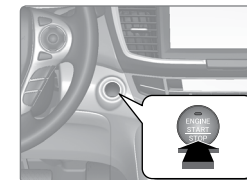

Shifting

Change the shift position based on your driving needs.

Continuously Variable Transmission (CVT)*

Park (P): Used for parking or starting/stopping the engine. Press the brake pedal, then press the release button to shift.

Reverse (R): Used for reversing.

Neutral (N): Used for idling.

Drive (D): Used for normal driving.

Drive (S): Used for better acceleration, increased engine braking, driving in hilly terrain, or paddle shifting*.

Low (L)*: Used for stronger engine power and braking when driving in hilly terrain.

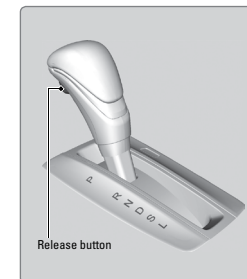

NOTICE

When you change the shift lever from D to R and vice versa, come to a complete stop and keep the brake pedal depressed. Operating the shift lever before the vehicle has come to a complete standstill can damage the transmission.

Do not operate the shift lever while pressing the accelerator pedal. You could damage the transmission.

*if equipped

■ Paddle Shifters*

Use the paddle shifters to change gears without removing your hands from the steering wheel.

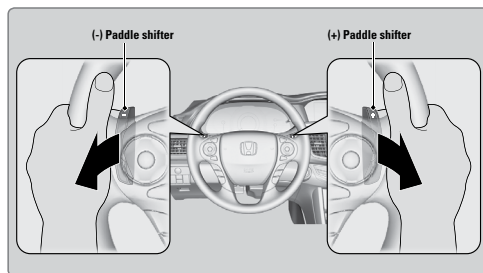

Recommended shift points

Shift up	Normal acceleration
1 to 2	15 mph (24 km/h)
2 to 3	25 mph (40 km/h)
3 to 4	40 mph (64 km/h)
4 to 5	45 mph (72 km/h)
5 to 6	50 mph (80 km/h)
6 to 7	55 mph (89 km/h)

When the shift lever is in D: The vehicle goes into manual shift mode temporarily, and the gear number appears in the instrument panel. When you start traveling at a constant speed or accelerate, manual shift mode automatically turns off, and the gear number goes off.

To cancel manual shift mode, pull and hold the (+) paddle shifter for a few seconds.

When the shift lever is in S: The vehicle goes into manual shift mode, and the M indicator and gear number appear in the instrument panel. When the vehicle comes to a stop, it automatically shifts down into 1st gear. You can pull away only in 1st gear. If the vehicle speed increases and the engine speed approaches the tachometer's red zone, the transmission automatically shifts up.

To cancel manual shift mode, move the shift lever from S to D. The M indicator and gear number go off.

*if equipped

■ Manual Transmission*

Fully press the clutch pedal to operate the shift lever and change gears.

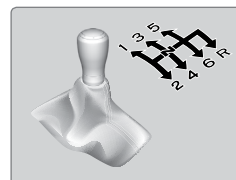

Recommended shift points (LX models)

Shift up	Normal acceleration
1 to 2	17 mph (27 km/h)
2 to 3	29 mph (46 km/h)
3 to 4	37 mph (60 km/h)
4 to 5	43 mph (69 km/h)
5 to 6	49 mph (79 km/h)

Recommended shift points (except LX models)

Shift up	Normal acceleration
1 to 2	15 mph (24 km/h)
2 to 3	25 mph (40 km/h)
3 to 4	40 mph (64 km/h)
4 to 5	47 mph (76 km/h)
5 to 6	52 mph (84 km/h)

NOTICE

Do not shift to Reverse (R) before the vehicle comes to a complete stop. This can damage the transmission.

NOTICE

Before downshifting, make sure the engine will not go into the tachometer's red zone. This can severely damage your engine.

*if equipped

Braking

Slow down or stop your vehicle, and keep it from moving when parked.

■ Foot Brake

Press the brake pedal to slow down or stop your vehicle from moving.

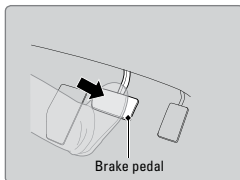

■ Brake Assist System

During hard or emergency braking, the system increases braking force. The brake pedal may move slightly or make a noise; this is normal. Continue to hold the brake pedal firmly down.

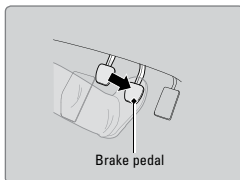

■ Anti-Lock Brake System (ABS)

During hard or emergency braking, the system rapidly pumps the brakes to prevent wheel lockup and help you maintain steering control. Do not pump the brake pedal, rather continue to hold it firmly down.

When ABS activates, you may notice vibrations through the brake pedal or the vehicle body, the brake pedal depressing further than usual, or hear a motor noise from the engine compartment. These are all normal.

In normal use, the ABS system will occasionally cause a motor sound from the engine compartment, especially when the engine is first started or after repeated use of the brakes.

NOTICE

The ABS may not function correctly if you use an incorrect tire type and size.

■ Parking Brake

Keep the vehicle from moving when it is parked.

To apply: Pull the lever up fully without pressing the release button.

To release: Press and hold the release button, then lower the lever down all the way.

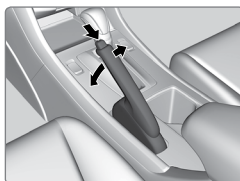

NOTICE

Release the parking brake fully before driving. The rear brakes and axle can be damaged if you drive with the parking brake applied.

Eco Assist System

Can help improve fuel economy by adjusting the performance of the engine, transmission, climate control system, and cruise control.

■ ECON Button

Press the ECON button to turn the system on or off. The ECON Mode indicator and a message in the multi-information display* appear when the system is turned on.

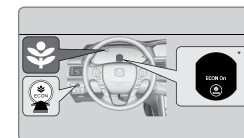

■ Ambient Meter

Color-coded bars change based on your driving style and brake or accelerator pedal operation.

Green: Fuel-efficient driving

Light green: Moderate acceleration/deceleration

White: Spirited acceleration/deceleration

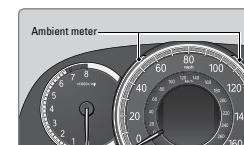

Vehicle Stability Assist (VSA®)

Also known as Electronic Stability Control (ESC), VSA helps to stabilize the vehicle during cornering if the vehicle turns more or less than what was intended. It assists in maintaining traction on slippery surfaces by regulating engine output and selectively applying the brakes.

■ Turning VSA On or Off

VSA is turned on every time you start the engine, even if you previously turned it off. If you turn VSA off, your vehicle has normal braking and cornering ability, but VSA traction and stability enhancement become less effective.

Press and hold the VSA OFF button until you hear a beep to turn VSA on or off. The VSA OFF indicator appears when the system is off.

Traction control becomes less effective, which may make it easier when trying to free your vehicle if it is stuck in mud or snow.

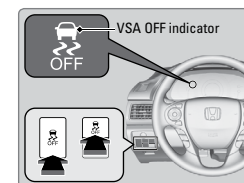

*if equipped

Cruise Control*

Maintain a constant vehicle speed without having to keep your foot on the accelerator pedal. Use cruise control on freeways or open roads where you can travel at a constant speed with little acceleration or deceleration.

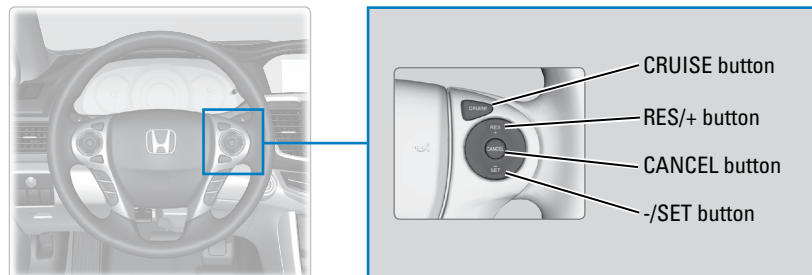

■ Activating and Setting the Vehicle Speed

1. Press the CRUISE button. The CRUISE MAIN indicator appears.
2. Accelerate to the desired speed (above 25 mph/40 km/h). Take your foot off the pedal and press the -/SET button to set the speed. The CRUISE CONTROL indicator appears.



■ Adjusting the Vehicle Speed

Press the RES/+ button to increase speed, or the -/SET button to decrease speed.

Each time you press the button, the vehicle speed is increased or decreased by about 1 mph (1.6 km/h). If you keep the button pressed, the vehicle speed increases or decreases until you release it.



■ Canceling Cruise Control

Press the CANCEL or CRUISE button or the brake pedal. The CRUISE CONTROL indicator goes off.

After cruise control has been canceled, you can still resume the prior set speed by pressing the RES/+ button while driving at a speed of at least 25 mph (40 km/h).

Press the CRUISE button to turn the system off.



⚠ WARNING
 Improper use of cruise control can lead to a crash.
 Use cruise control only when traveling on open highways in good weather.

*if equipped

Adaptive Cruise Control (ACC)*

Helps maintain a constant vehicle speed and a set following interval behind a vehicle detected ahead of yours.

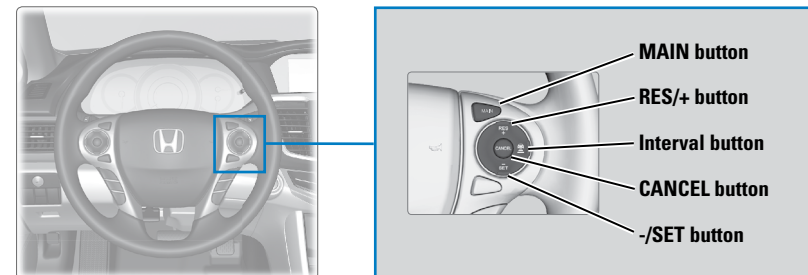

■ Activating and Setting the Vehicle Speed

1. Press the MAIN button. The ACC indicator appears in the multi-information display.
2. Accelerate to the desired speed (above 25 mph/40 km/h). Take your foot off the pedal and press the -/SET button to set the speed.



■ Adjusting the Vehicle Speed

Press the RES/+ button to increase speed or the -/SET button to decrease speed.

Each time you press the button, the vehicle speed is increased or decreased by about 1 mph (1.6 km/h). If you keep the button pressed, the vehicle speed increases or decreases by 5 mph or 5 km/h until you release it.



■ Adjusting the Following Interval

Press the Interval button to change the following interval. Each time you press the button, the setting cycles through extra long, long, middle, and short.

Interval	Short	Middle	Long	Extra Long
Approx. Gap (seconds)	1.1	1.5	2.1	3.0



*if equipped

■ During Operation

If a vehicle is detected ahead of you when ACC is turned on, the system maintains, accelerates, or decelerates your vehicle's set speed to keep the vehicle's set following interval from the vehicle ahead.

You can temporarily increase the vehicle speed when you press the accelerator pedal. ACC stays on unless you cancel it. When you release the accelerator pedal, the system resumes the set speed or a sufficient speed to maintain the following interval.

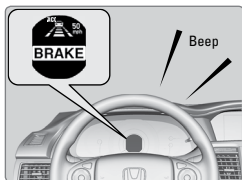

If a vehicle detected ahead of you slows down abruptly, or if another vehicle cuts in front of you, a beep sounds and BRAKE appears on the multi-information display to alert you.

⚠ WARNING

ACC has limited braking capability.

When your vehicle speed drops below 22 mph (35 km/h), ACC will automatically cancel and no longer will apply your vehicle's brakes.

Always be prepared to apply the brake pedal when conditions require.

■ Canceling ACC

Press the CANCEL or MAIN button, or press the brake pedal. The ACC indicator goes off.

Certain conditions may cause ACC to cancel automatically. When this happens, the amber ACC indicator appears on the multi-information display (see page 23).



After adaptive cruise control has been canceled, you can still resume the prior set speed by pressing RES/+ when your vehicle speed is over 25 mph (40 km/h).

⚠ WARNING

Improper use of ACC can lead to a crash.

Use ACC only when traveling on open highways in good weather.

Road Departure Mitigation (RDM)*

Alerts and helps to assist you if the system determines a possibility of your vehicle unintentionally crossing over detected lane markings while driving between 45–90 mph (72–145 km/h).

If your vehicle is getting too close to detected lane markings without a turn signal activated, a message appears in the multi-information display. Steering wheel torque and vibrations are applied to help your vehicle stay in the lane.

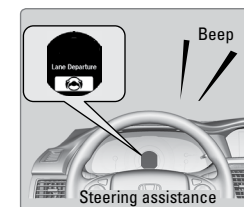

Braking may also be applied if the lane lines are solid and continuous.

If the system operates several times without detecting driver response, the system beeps to alert you.

■ Turning the System On or Off

Press the RDM button to turn the system on or off. A green indicator appears on the button when the system is on.

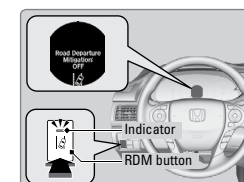

■ Changing Settings

Determine the warning timing. The vehicle must be in Park (P).

1. *Models with one display:* Press the SETTINGS button. Select Vehicle Settings. *Models with touchscreen:* From the HOME screen, select Settings. Select Vehicle.
2. Select Driver Assist System Setup.
3. Select Road Departure Mitigation Setting.
4. Select from the options.

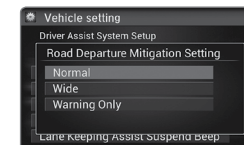

Normal (default): Steering control starts from inside the lane edge.

Wide: Steering control starts from outside the lane edge.

Warning Only: The system only provides a BRAKE message, but does not apply steering or braking.

5. Press BACK to exit the menu.

Important Safety Reminder

The RDM system has limitations. Over-reliance on it may result in a collision. It is always your responsibility to keep your vehicle within the driving lane.

*if equipped

Lane Keeping Assist System (LKAS)*

Provides steering input to help keep the vehicle in the middle of a detected lane and visual and tactile alerts if the vehicle is detected drifting out of its lane while driving between 45–90 mph (72–145 km/h).

If your vehicle is getting too close to detected left or right side lane markings without a turn signal activated, the system provides visual and tactile alerts.

A Lane Departure message appears on the multi-information display, and the steering wheel vibrates. Steering torque is also applied to help keep your vehicle within your driving lane. Take appropriate action to stay within your driving lane.



Turning the System On or Off

1. Press the MAIN button. LKAS appears in the multi-information display.

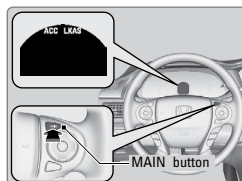

2. Press the LKAS button. Lane outlines appear in the multi-information display. Dotted lane lines turn solid when the system activates.

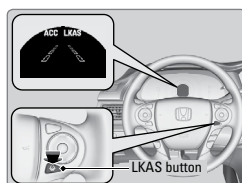

3. Press the MAIN button or the LKAS button to turn the system off.

Important Safety Reminder

LKAS is for your convenience only. It is not a substitute for your vehicle control. The system does not work if you take your hands off the steering wheel or fail to steer the vehicle.

Do not place an object on the top of the instrument panel. It may reflect onto the windshield and prevent the system from detecting lane lines properly.

*if equipped

LaneWatch™*

Check the passenger-side rear areas in the upper display when the right turn signal is activated.

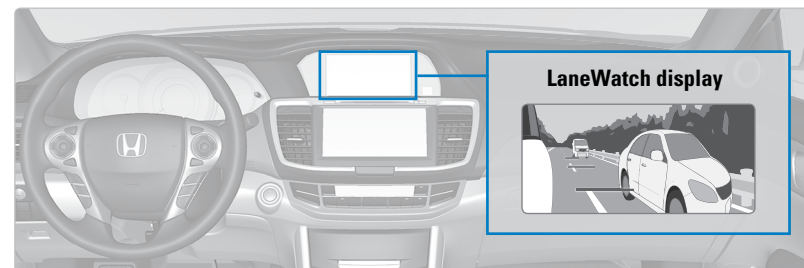

Activating LaneWatch

Activate the right turn signal. The LaneWatch display appears. Check the display for blind spots, and visually confirm that it is safe to change lanes.

You can also press the LaneWatch button on the end of the turn signal switch to view a constant real-time display. Press it again to turn the display off.

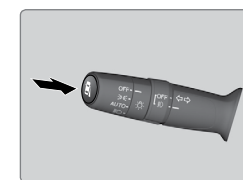

Changing Settings

Customize the display and how and when the display appears.

1. From the Home screen, select Settings.
2. Select Camera.
3. Select LaneWatch.
4. Select an option and make the preferred changes.
5. Press BACK to exit the menu.



Important Safety Reminder

Like all assistance systems, LaneWatch has limitations. Over-reliance on the system may result in a collision.

WARNING

Failure to visually confirm that it is safe to change lanes before doing so may result in a crash and serious injury or death.

Do not rely only on LaneWatch while driving. Always look in your mirrors, to either side of your vehicle, and behind you for other vehicles before changing lanes.

*if equipped

Collision Mitigation Braking System™ (CMBS™)*

Can assist you when there is a possibility of your vehicle colliding with a vehicle or a pedestrian detected in front of yours.

The system can give you visual, audible, and tactile alerts when a potential collision is determined, and reduce your vehicle speed to help minimize collision severity when a collision is deemed unavoidable.

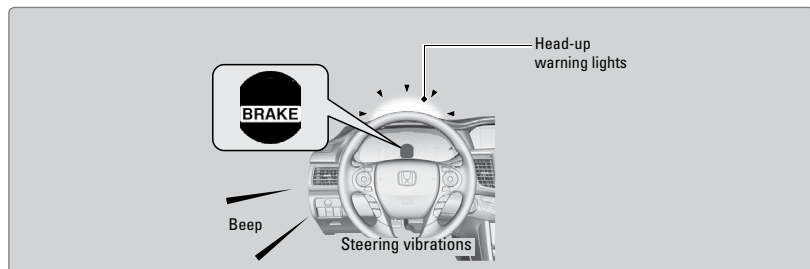

When a potential collision with a detected oncoming vehicle is determined, a BRAKE message appears in the multi-information display, the head-up warning lights flash, and a beep sounds.

The system activates when:

- The speed difference between your vehicle and a vehicle or pedestrian detected in front of you is about 3 mph (5 km/h) and over with a chance of a collision.
- Your vehicle speed is about 62 mph (100 km/h) or less and there is a chance of a collision with an oncoming detected vehicle or a pedestrian in front of you.

Alert Stages

The system has three alert stages for a possible collision. Depending on the circumstances or CMBS settings, CMBS may not go through all of the stages before initiating the last stage.

Stage 1: Visual and audible warning, steering wheel vibrations

Stage 2: Visual and audible warning, light brake application

Stage 3: Visual and audible warning, strong brake application

Important Safety Reminder

CMBS is designed to reduce the severity of an unavoidable collision. It does not prevent collisions nor stop the vehicle automatically. It is still your responsibility to operate the brake pedal and steering wheel appropriately according to the driving conditions.

*if equipped

Changing Settings

Determine the warning timing. The vehicle must be in Park (P).

1. From the HOME screen, select Settings.
2. Select Vehicle.
3. Select Driver Assist System Setup.
4. Select Forward Collision Warning Distance.
5. Select Long, Normal, or Short.
6. Press BACK to exit the menu.

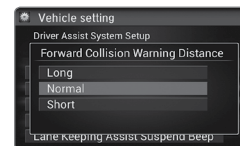

Turning CMBS On or Off

Press and hold the CMBS OFF button. A beep sounds and a message appears in the multi-information display. The CMBS indicator appears when the system is off.

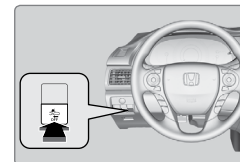

Parking Sensor System*

When the system senses an object when you are parking or backing up, indicators appear on the upper display and a series of beeps will sound.

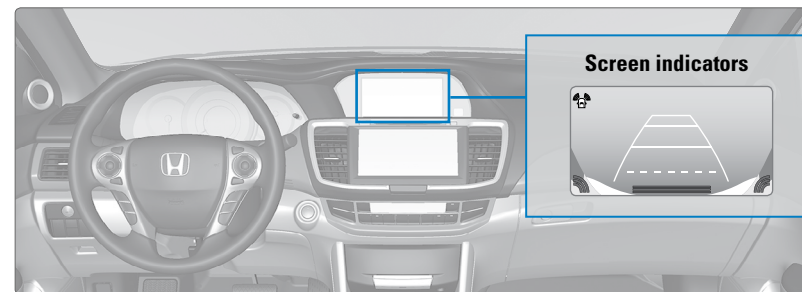

Turning the System On or Off

Press the parking sensor button to turn the system on or off. A green indicator light appears on the button when the system is on.

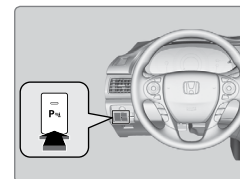

*if equipped

Multi-View Rear Camera

When you shift into Reverse (R), a real-time image of the area behind your vehicle is shown in the upper display, along with helpful parking guidelines.

Press the selector knob or touch icons on the screen to change views.

Wide view

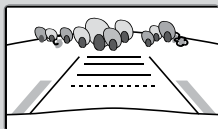

Normal view

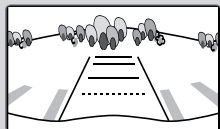

Top down view

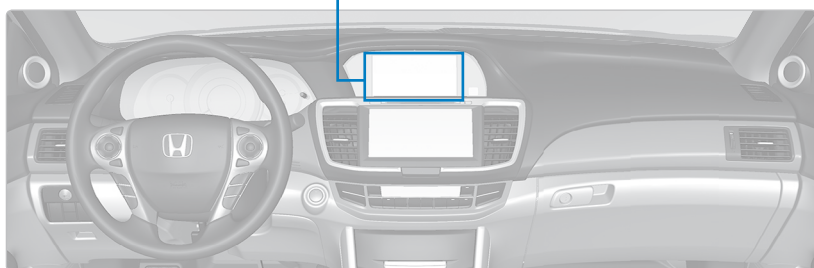
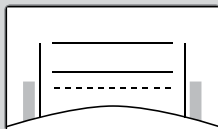

Changing Camera Settings

Turn the guidelines on or off.

1. *Models with one display:* Press the SETTINGS button.
Models with touchscreen: From the HOME screen, select Settings.
2. Select Camera.
3. Select Rear Camera.
4. Select an option.
Fixed Guidelines: Guidelines appear when you shift into Reverse.
Dynamic Guidelines: Guidelines move as you turn the steering wheel.
5. Select On or Off.
6. Press BACK to exit the menu.

The rear camera view is restricted. You cannot see the corner ends of the bumper or what is underneath the bumper. Its unique lens also makes objects appear closer or farther than they actually are.

Visually confirm that it is safe to drive before backing up. Certain conditions (such as weather, lighting, and high temperatures) may also restrict the rear view. Do not rely on the rearview display, which does not give you all information about conditions at the rear of your vehicle.

Refueling

Use the proper fuel and refueling procedure to ensure the best performance and safety of your vehicle.

Fuel Information

Use of unleaded gasoline of 87 octane or higher is recommended.

- Honda recommends TOP TIER Detergent Gasoline where available.
- Do NOT use gasoline containing more than 15% ethanol.
- Do NOT use gasoline containing methanol.
- Do NOT use gasoline containing MMT.

NOTICE

We recommend quality gasoline containing detergent additives that help prevent fuel system and engine deposits. In addition, in order to maintain good performance, fuel economy, and emissions control, we strongly recommend the use of gasoline that does NOT contain harmful manganese-based fuel additives such as MMT, if such gasoline is available.

How to Refuel

1. The fuel fill door is located at the left rear of the vehicle. Park next to the service pump that is most accessible.
2. Turn off the engine.
3. Push the fuel fill door release handle near the bottom of the driver's seat. The fuel fill door opens.
4. Turn the fuel fill cap slowly to open. Place the fuel fill cap in the holder.
5. Insert the filler nozzle fully. When the tank is full, the fuel nozzle clicks off automatically.
6. Replace the fuel fill cap. Tighten it until you hear at least one click. Close the fuel fill door.

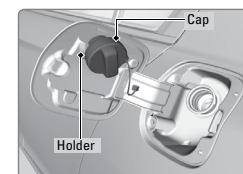
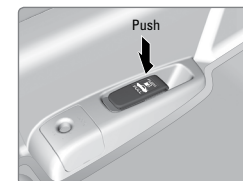

WARNING

Gasoline is highly flammable and explosive. You can be burned or seriously injured when handling fuel.

- Stop the engine, and keep heat, sparks, and flame away.
- Handle fuel only outdoors.
- Wipe up spills immediately.

HANDLING THE UNEXPECTED

Learn about what to do in critical or emergency situations.

Smart Entry Remote Battery Strength*

If the battery life in your remote transmitter is weak, a beep sounds and the ENGINE START/STOP button indicator flashes. A message appears in the multi-information display with information on how to start the engine.*

1. Touch the back of the remote transmitter to the ENGINE START/STOP button while the indicator is flashing.
2. With the brake pedal or clutch pedal pressed, press the ENGINE START/STOP button within 10 seconds.

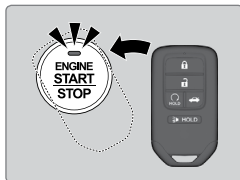

Shift Lever Does Not Move*

Follow the procedure below if you cannot move the shift lever out of Park (P).

1. Set the parking brake.
2. Remove the key from the ignition, or remove the built-in key from the remote transmitter.
3. Wrap a cloth around the tip of a small flat-tip screwdriver. Put it into the shift lock release slot as shown in the image, and remove the cover.
4. Insert the key into the shift lock release slot.
5. While pushing the key down, press the shift lever release button and place the shift lever into Neutral (N). The lock is now released. Have the shift lever checked by a dealer as soon as possible.

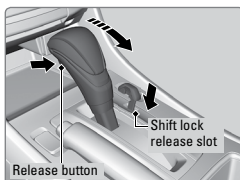
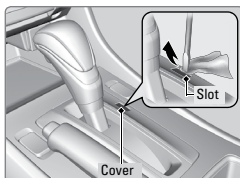

*if equipped

Jump Starting

Turn off the power to electric devices, such as audio and lights. Turn off the engine, then open the hood.

1. Connect the first jumper cable to your vehicle's battery (+) terminal.
2. Connect the other end of the first jumper cable to the booster battery (+) terminal. Use a 12-volt booster battery only.
3. Connect the second jumper cable to the booster battery (-) terminal.
4. Connect the other end of the second jumper cable to the engine mounting bolt as shown. Do not connect this jumper cable to any other part.
5. If your vehicle is connected to another vehicle, start the assisting vehicle's engine and increase its rpm slightly.
6. Attempt to start your vehicle's engine. If it turns over slowly, make sure that the jumper cables have good metal-to-metal contact.

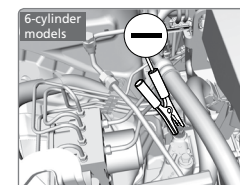
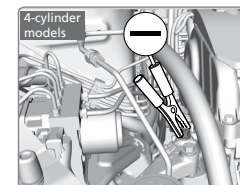
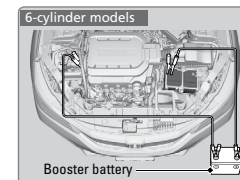
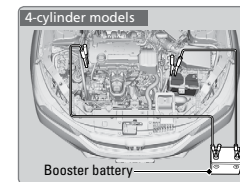

WARNING: Battery posts, terminals, and related accessories contain lead and lead compounds. **Wash your hands after handling.**

WARNING

A battery can explode if you do not follow the correct procedure, seriously injuring anyone nearby.

Keep all sparks, open flames, and smoking materials away from the battery.

■ After the Engine Starts

Once your vehicle's engine has started, remove the jumper cables in the following order:

1. Disconnect the jumper cable from your vehicle's ground.
2. Disconnect the other end of the jumper cable from the booster battery's (-) terminal.
3. Disconnect the jumper cable from your vehicle battery's (+) terminal.
4. Disconnect the other end of the jumper cable from the booster battery's (+) terminal.
5. Have your vehicle inspected by a nearby service station or a dealer.

Overheating

If the temperature gauge needle is at the H mark, the engine suddenly loses power, or steam or spray comes out from under the hood, your engine is overheating.

1. Immediately park the vehicle in a safe place. Turn off all accessories and turn on the hazard warning lights.

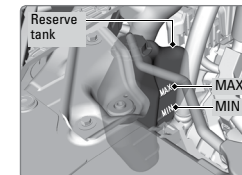

2. *If steam or spray is not present:* Keep the engine running and open the hood.

If steam or spray is present: Turn off the engine and wait until it subsides. Then, open the hood.

3. Check that the cooling fan is operating and stop the engine once the temperature gauge needle goes down. If the cooling fan is not operating, immediately stop the engine.
4. Once the engine has cooled down, inspect the coolant level and check the cooling system components for leaks. If the coolant level in the reserve tank is low, add coolant until it reaches the MAX mark. If there is no coolant in the reserve tank, make sure the radiator is cool, then cover the radiator cap with a heavy cloth and open the cap. If necessary, add coolant up to the base of the filler neck, and put the cap back on.

Once the engine has cooled sufficiently, restart it and check the temperature gauge. If the temperature gauge needle has gone down, resume driving. If it has not gone down, contact a dealer for repairs.

⚠ WARNING

Steam and spray from an overheated engine can seriously scald you.
Do not open the hood if steam is coming out.

⚠ WARNING

Removing the radiator cap while the engine is hot can cause the coolant to spray out, seriously scalding you.
Always let the engine and radiator cool down before removing the radiator cap.

NOTICE

Continuing to drive with the temperature gauge needle at the H mark may damage the engine.

Emergency Engine Stop*

The ENGINE START/STOP button may be used to stop the engine due to an emergency situation even while driving. If you must stop the engine, choose one of the following operations:

- Press and hold the ENGINE START/STOP button for two seconds, or
- Firmly press the ENGINE START/STOP button two times.

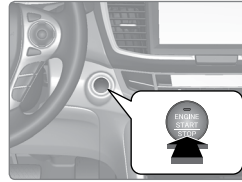

The steering wheel will not lock. Because turning off the engine also disables the power assist the engine provides to the steering and braking systems, it will require significantly more physical effort and time to steer and slow the vehicle. Downshift gears and use both feet on the brake pedal, if necessary, to slow the vehicle and stop immediately in a safe place.

NOTICE

Do not press the button while driving unless it is absolutely necessary for the engine to be switched off.

Emergency Towing

Call a professional towing service if you need to tow your vehicle.

Flat bed equipment: The operator loads your vehicle on the back of a truck. **This is the best way to transport your vehicle.**

Wheel lift equipment: The tow truck uses two pivoting arms that go under the front tires and lift them off the ground. The rear tires remain on the ground. **This is an acceptable way to tow your vehicle.**

NOTICE

Trying to lift or tow your vehicle by the bumpers will cause serious damage. The bumpers are not designed to support the vehicle's weight.

Improper towing such as towing behind a motorhome or other motor vehicle can damage the transmission.

*if equipped

Tire Pressure Monitoring System (TPMS)

Monitors the tire pressure while you are driving.

If your vehicle's tire pressure becomes significantly low, the low tire pressure indicator comes on and a message appears on the multi-information display*.

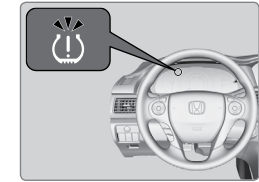

■ What to Do

Stop your vehicle in a safe place. Check the tire pressure and adjust the pressure to the specified level on the label on the driver's doorjamb.

■ TPMS Calibration

Any time you inflate, change, or rotate one or more of the tires, you need to recalibrate the system. The calibration process requires approximately 30 minutes of cumulative driving at speeds between 30–60 mph (48–97 km/h). The vehicle must be steopped to begin calibration, and the process finishes automatically.

Using the TPMS button*

Press and hold the TPMS button near the steering wheel. The TPMS indicator blinks twice, and calibration begins.

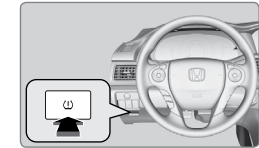

Using the Settings menu*

Use the selector knob or the touchscreen to make and enter selections.

1. *Models with one display:* Press the SETTINGS button. Select Vehicle Settings.
Models with touchscreen: From the HOME screen, select Settings. Select Vehicle.
2. Select TPMS Calibration.
3. Select Calibrate, and calibration begins.



Using the multi-information display*

Use the Info (▲/▼) and SEL/RESET buttons on the steering wheel to make and enter selections.

1. Scroll to the Vehicle Settings screen, and select it.
2. Select TPMS Calibration.
3. Select Calibrate, and calibration begins.

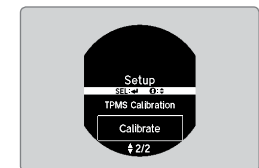

*if equipped

NOTICE

Driving on an extremely underinflated tire can cause it to overheat. An overheated tire can fail. Always inflate your tires to the specified pressure.

■ Tire Pressure Monitoring System (TPMS) - Required Federal Explanation

U.S. models

Each tire, including the spare (if provided), should be checked monthly when cold and inflated to the inflation pressure recommended by the vehicle manufacturer on the vehicle placard or tire inflation pressure label.

(If your vehicle has tires of a different size than the size indicated on the vehicle placard or tire inflation pressure label, you should determine the proper tire inflation pressure for those tires.)

As an added safety feature, your vehicle has been equipped with a tire pressure monitoring system (TPMS) that illuminates a low tire pressure telltale when one or more of your tires is significantly underinflated.



Accordingly, when the low tire pressure telltale illuminates, you should stop and check your tires as soon as possible, and inflate them to the proper pressure.

Driving on a significantly underinflated tire causes the tire to overheat and can lead to tire failure. Underinflation also reduces fuel efficiency and tire tread life, and may affect the vehicle's handling and stopping ability.

Please note that the TPMS is not a substitute for proper tire maintenance, and it is the driver's responsibility to maintain correct tire pressure, even if underinflation has not reached the level to trigger illumination of the TPMS low tire pressure telltale.

Your vehicle has also been equipped with a TPMS malfunction indicator to indicate when the system is not operating properly. The TPMS malfunction indicator is combined with the low tire pressure telltale. When the system detects a malfunction, the telltale will flash for approximately one minute and then remain continuously illuminated. This sequence will continue upon subsequent vehicle start-ups as long as the malfunction exists.

When the malfunction indicator is illuminated, the system may not be able to detect or signal low tire pressure as intended.

TPMS malfunctions may occur for a variety of reasons, including the installation of replacement or alternate tires or wheels on the vehicle that prevent the TPMS from functioning properly.

Always check the TPMS malfunction telltale after replacing one or more tires or wheels on your vehicle to ensure that the replacement or alternate tires and wheels allow the TPMS to continue to function properly.

Changing a Flat Tire

If a tire goes flat while driving, grasp the steering wheel firmly, and brake gradually to reduce speed. Then, stop in a safe place. Replace the flat tire with the compact spare tire. Go to a dealer as soon as possible to have the full-size tire repaired or replaced.

■ Getting Ready to Change the Tire

Park the vehicle on a firm, level, non-slippery surface. Apply the parking brake, shift to Park (P), and turn the vehicle off. Turn on the hazard warning lights.

1. Open the trunk floor lid.

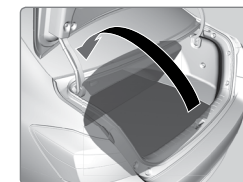

2. Take the tool case out of the trunk. Take the jack and wheel nut wrench out of the tool case.

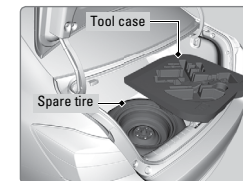

3. Unscrew the wing bolt, then remove the spacer cone. Remove the spare tire.

4. Place the compact spare tire (wheel side up) under the vehicle body, near the tire that needs to be replaced.

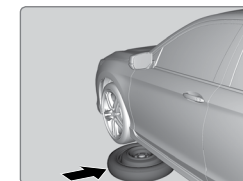

5. Loosen each wheel nut about one turn using the wheel nut wrench.

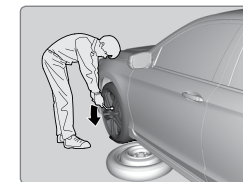

■ Setting Up the Jack

1. Place the jack under the jacking point closest to the tire to be changed.

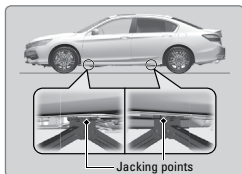

2. Turn the end bracket clockwise (as shown in the image) until the top of the jack contacts the jacking point. Make sure that the jacking point tab is resting in the jack notch.

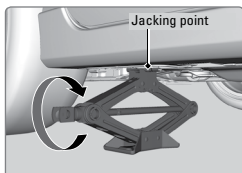

3. Raise the vehicle, using the jack handle bar and the jack handle, until the tire is off the ground.

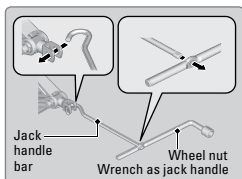

⚠ WARNING

The vehicle can easily roll off the jack, seriously injuring anyone underneath. Follow the directions for changing a tire exactly, and never get under the vehicle when it is supported only by the jack.

The following instructions must be followed to use the jack safely:

- Do not use the jack with people or luggage in the vehicle.
- Use the jack provided in your vehicle. Other jacks may not support the weight ("load") or fit the jacking point.
- Do not use while the engine is running.
- Use only where the ground is firm and level.
- Use only at the jacking points.
- Do not get in the vehicle while using the jack.
- Do not put anything on top of or underneath the jack.

■ Replacing the Flat Tire

1. Remove the wheel nuts and flat tire.
2. Mount the compact spare tire. Replace the wheel nuts, and lightly tighten them.
3. Lower the vehicle and remove the jack. Tighten the wheel nuts in the order indicated in the image. Go around, tightening the nuts, two to three times in this order. Do not overtighten the wheel nuts.

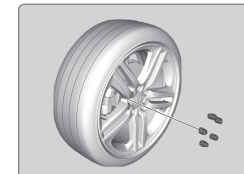

If you drive with the spare tire installed, the low tire pressure/TPMS indicator appears. The indicator stays on until a regular tire is installed.

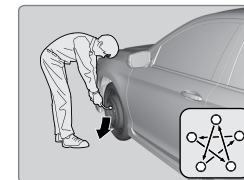

■ Storing the Flat Tire

1. Remove the center cap.
2. Open the trunk. Place the flat tire face down in the spare tire well.
3. Remove the spacer cone from the wing bolt, flip it over, and insert it back on the bolt. Secure the flat tire with the wing bolt.
4. Securely put the jack and wheel nut wrench back in the tool case. Store the case in the trunk.

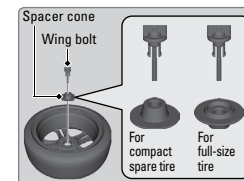

⚠ WARNING

Loose items can fly around the interior in a crash and can seriously injure the occupants.

Store the wheel, jack, and tools securely before driving.

Fuse Locations

If any electrical devices are not working, turn the vehicle off and check to see if any applicable fuse is blown. Fuse locations are shown on the fuse box cover. Locate the fuse in question by the fuse number and box cover number.

Engine Compartment Fuse Box

Located under the hood near the brake fluid reservoir. Push the tabs to open the box.

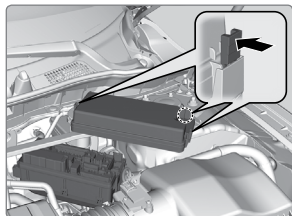

	Circuit Protected	Amps
1	Battery	125 A
	EPS	70 A
	Fuse Box Main 1	(60 A)
	Fuse Box Option 1	(40 A)
2	-	-
	-	-
	ABS/VSA FSR	20 A ^{*1} 40 A ^{*2}
3	ABS/VSA Motor	40 A ^{*1} 30 A ^{*2}
	-	-
4	-	-
	-	-
	-	-
	-	-
	Front Fog Light *	(10 A)
	Horn	10 A
	Stop Light	10 A
	FI Sub	15 A
	DRL	(7.5 A)
	IG Coil	15 A
10	Injector ^{*3}	(20 A) ^{*3}
	- ^{*4}	- ^{*4}

	Circuit Protected	Amps	
11	Hazard	15 A	
	Fuse Box Main 2	60 A	
	Fuse Box Option 2	(40 A)	
	IG Main 1	30 A ^{*5} 50 A ^{*6}	
	IG Main 2 ^{*5}	30 A ^{*5} - ^{*6}	
	- ^{*6}	- ^{*6}	
12	Sub Fan Motor	20 A ^{*3} 30 A ^{*4}	
	Headlight Low Beam Main	30 A	
	Fuse Box	30 A	
	Wiper Motor	30 A	
	Main Fan Motor	30 A	
	Starter Motor ^{*5}	30 A ^{*5} - ^{*6}	
	- ^{*6}	- ^{*6}	
	13	Rear Defogger	40 A
	14	Heater Motor	40 A
	15	FI Main	15 A
16	Heated Door Mirror ^{*3}	(10 A) ^{*3}	
	- ^{*4}	- ^{*4}	
17	MG Clutch	7.5 A	
18	DBW	15 A	
19	Small Light	20 A	
20	Interior Light	7.5 A	
21	Back Up	10 A	
22	Audio	10 A	
23	Fan Timer	7.5 A	
24	Right Headlight Low Beam	10 A	
25	Left Headlight Low Beam	10 A	
26	ABS/VSA ECU ^{*1}	7.5 A ^{*1}	
	- ^{*2}	- ^{*2}	

- *1: Models with LKAS
- *2: Models without LKAS
- *3: 4-cylinder models
- *4: 6-cylinder models
- *5: Models with smart entry system
- *6: Models without smart entry system

*if equipped

Interior Fuse Box

Located under the dashboard on the driver's side.

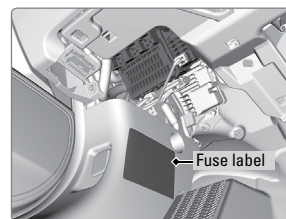

	Circuit Protected	Amps
1	A/C	7.5 A
2	DRL	7.5 A
3	-	-
4	-	-
5	Meter	7.5 A
6	SRS	7.5 A
7	Option	(7.5 A)
8	MISS SOL	10 A
9	Fuel Pump	20 A
10	ABS/VSA	7.5 A
11	-	-
12	Front Wiper	7.5 A
13	ACG	15 A
14	Rear Accessory Power Socket (Console Compartment)	(20 A)
	Driver's Power Seat Reclining *	(20 A)
16	Moonroof *	(20 A)
17	Front Seat Heaters *	(20 A)
18	-	-
19	Passenger Side Door Unlock	10 A
20	Driver Side Rear Door Unlock	10 A

	Circuit Protected	Amps
21	Driver's Door Lock	10 A
22	Passenger Side Door Lock	10 A
23	Driver's Door Unlock	10 A
24	SRS	10 A
25	Illumination	10 A
26	Key Lock	7.5 A
27	Parking Lights	10 A
28	Lumbar Support *	(10 A)
29	Right Headlight High Beam	10 A
30	Washer	15 A
31	SMART [*]	(10 A)
32	Driver's Power Window	20 A
33	Front Passenger's Power Window	20 A
	Rear Driver Side Power Window	20 A
34	Rear Passenger Side Power Window	20 A
35	Driver's Power Seat Sliding *	(20 A)
36	ACCESSORY	7.5 A
37	-	-
38	-	-
39	Left Headlight High Beam	10 A
40	Front Accessory Power Socket (Console Panel)	20 A
41	Driver Side Rear Door Lock	10 A
42	Door Lock	20 A
a	Audio *	(7.5 A)
b	ACM *	(20 A)
c	Rear Seat Heaters *	(15 A)
d	Premium Amp *	(20 A)
e	-	-
f	-	-
g	Passenger's Power Seat Reclining *	(20 A)
h	Passenger's Power Seat Sliding *	(20 A)

*if equipped

■ Inspecting and Changing Fuses

1. Turn the vehicle off, including all lights and accessories.
2. Remove the fuse box cover.
3. Check the large fuse in the engine compartment.

If the fuse is blown, use a Phillips-head screwdriver to remove the screws and replace the fuse with a new one. Reinstall the screws.

4. Inspect the small fuses in the engine compartment and the vehicle interior.

If there is a burned out fuse, remove it with the fuse puller and replace it with a new one.

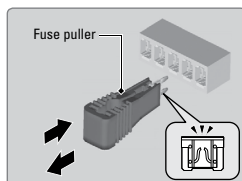
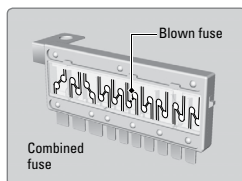

NOTICE

Replacing a fuse with one that has a higher rating greatly increases the chances of damaging the electrical system.

MAINTENANCE

Learn about basic maintenance that you can perform on the vehicle yourself, as well as information about how to best maintain the vehicle.

Safety Precautions

Some of the most important safety precautions are listed below; however, we cannot warn you of every conceivable hazard that can arise in performing maintenance. Only you can decide whether or not you should perform a given task.

■ Maintenance Safety

- To reduce the possibility of fire or explosion, keep cigarettes, sparks, and flames away from the battery and all fuel-related parts.
- Never leave rags, towels, or other flammable objects under the hood. Heat from the engine and exhaust can ignite them, causing a fire.
- To clean parts, use a commercially available degreaser or parts cleaner, not gasoline.
- Wear eye protection and protective clothing when working with the battery or compressed air.
- Do not run the engine in confined spaces where carbon monoxide gas can accumulate.

■ Vehicle Safety

- The vehicle must be stationary, and parked on level ground with the parking brake set and the engine off.
- Be aware that hot parts can burn you.
- Be aware that moving parts can injure you.

⚠ WARNING

Improperly maintaining this vehicle or failing to correct a problem before driving can cause a crash in which you can be seriously hurt or killed.

Always follow the inspection and maintenance recommendations according to the schedules in this guide.

⚠ WARNING

Failure to properly follow maintenance instructions and precautions can cause you to be seriously hurt or killed.

Always follow the procedures and precautions in this guide.

Maintenance Minder™

Reminds you when indicated maintenance service is due.

Models with information display

When maintenance is due, the Maintenance Minder indicator appears every time you turn the vehicle on. Press the select/reset knob to change displays.

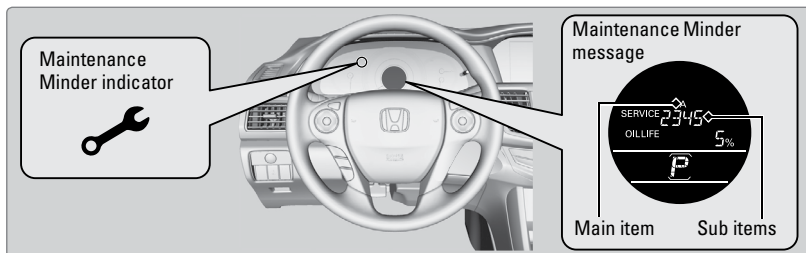

Models with multi-information display

When maintenance is due, the system message indicator comes on and a message appears on the multi-information display every time you turn the vehicle on. Press either Info (▲/▼) button on the steering wheel to change displays.

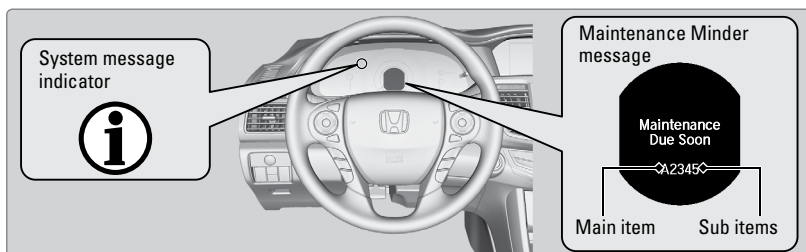

- Independent of the Maintenance Minder information, replace the brake fluid every 3 years.
- Inspect idle speed every 160,000 miles (256,000 km).
- Adjust the valves during services A, B, 1, 2, or 3 if they are noisy.

U.S. models

Maintenance, replacement, or repair of emissions control devices and systems may be done by any automotive repair establishment or individuals using parts that are certified to EPA standards.

According to state and federal regulations, failure to perform maintenance on the maintenance main items marked with # will not void your emissions warranties. However, all maintenance services should be performed in accordance with the intervals indicated by the display.

Maintenance Minder Service Codes

These codes indicate what services are due on your vehicle.

CODE	Maintenance Main Items
A	Replace engine oil* ¹
B	Replace engine oil* ¹ and oil filter Inspect front and rear brakes/service as necessary Check parking brake adjustment Inspect tie rod ends, steering gearbox, and boots Inspect suspension components Inspect driveshaft boots Inspect brake hoses and lines (Including ABS/VSA) Inspect all fluid levels and condition of fluids Inspect exhaust system# Inspect fuel lines and connections#

*1: If a message SERVICE does not appear more than 12 months after the display is reset, change the engine oil every year.

#: See information on maintenance and emissions warranty.

CODE	Maintenance Sub Items
1	Rotate tires
2	Replace air cleaner element* ² Replace dust and pollen filter* ³ Inspect drive belt
3	Replace transmission fluid* ^{4,5}
4	Replace spark plugs Replace timing belt and inspect water pump* ^{6,7} Inspect valve clearance
5	Replace engine coolant

*2: If you drive in dusty conditions, replace the air cleaner element every 15,000 miles (24,000 km).

*3: If you drive primarily in urban areas that have high concentrations of soot in the air from industry and diesel-powered vehicles, replace the dust and pollen filter every 15,000 miles (24,000 km).

*4: Continuously variable transmission (CVT) models

*5: Driving in mountainous areas at very low vehicle speeds or trailer towing results in higher transmission temperatures. This requires transmission fluid changes more frequently than recommended by the Maintenance Minder. If you regularly drive your vehicle under these conditions, have the transmission fluid changed every 25,000 miles (40,000 km).

*6: 6-cylinder models

*7: If you drive regularly in very high temperatures (over 110 °F, 43 °C), in very low temperatures (under -20 °F/-29 °C), or tow a trailer, replace every 60,000 miles/100,000 km.

Under the Hood

4-cylinder models

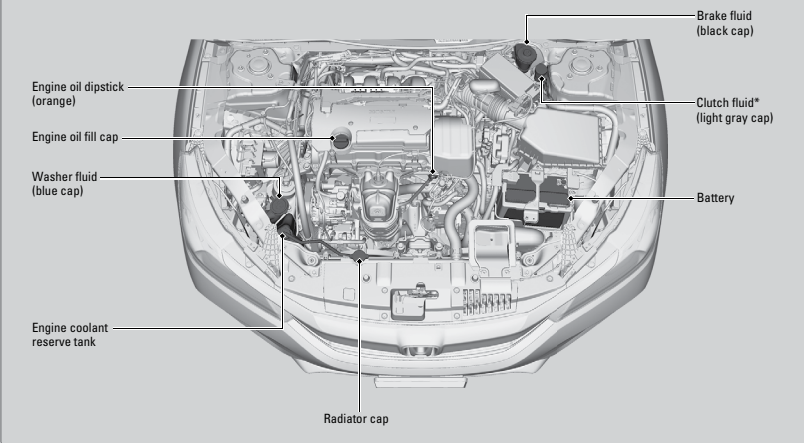

6-cylinder models

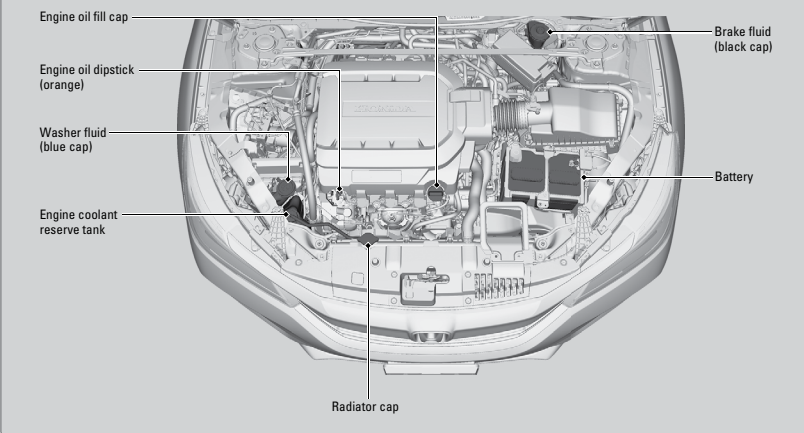

*if equipped

Opening the Hood

1. Park the vehicle on a level surface, and set the parking brake.
2. Pull the hood release handle under the lower left corner of the dashboard.
3. Push up the hood latch lever in the center of the hood to release the lock mechanism, then open the hood.

Follow the steps below to open and close the hood based on your engine type.

4-cylinder models

Remove the support rod from the clamp using the grip. Mount the support rod in the hood.

When closing, remove the support rod, and stow it in the clamp, then gently lower the hood. Remove your hand at a height of approximately 12 inches (30 cm) and let the hood close.

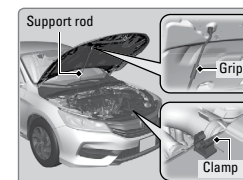
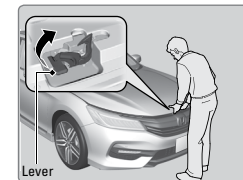
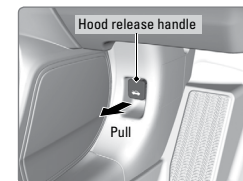

6-cylinder models

Lift the hood up most of the way. The hydraulic supports lift it up the rest of the way and hold it up.

When closing, lower it to approximately 12 inches (30 cm), then press down firmly with your hands.



NOTICE

Do not open the hood when the wiper arms are raised. The hood will strike the wipers, and may damage either the hood or the wipers.

Engine Oil

Park the vehicle on level ground, and wait approximately three minutes after turning the engine off before you check the oil.

■ Checking the Oil

1. Remove the dipstick (orange).

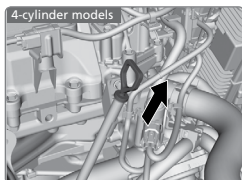

2. Wipe the dipstick with a clean cloth or paper towel.

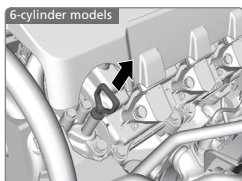

3. Insert the dipstick back all the way into its hole.

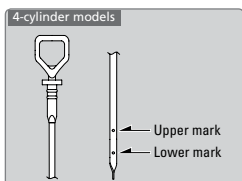

4. Remove the dipstick again, and check the level. It should be between the upper and lower marks. Add oil if necessary.

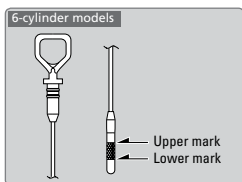

■ Recommended Engine Oil

- **Honda Genuine Motor Oil**
- **Premium-grade 0W-20 detergent oil with an API Certification Seal on the container**

This seal indicates the oil is energy conserving and that it meets the American Petroleum Institute's latest requirements.



Use Honda Genuine Motor Oil or another commercial engine oil of suitable viscosity for the ambient temperature as shown.

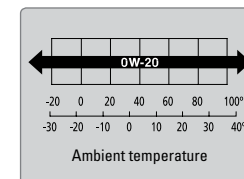

You may also use synthetic motor oil if it is labeled with the API Certification Seal and is of the specified viscosity grade.

■ Adding Oil

1. Unscrew and remove the engine oil fill cap.

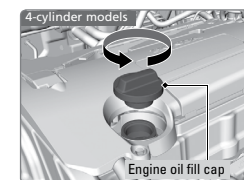

2. Add oil slowly.

3. Reinstall the engine oil fill cap, and tighten it securely.

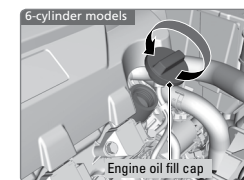

4. Wait for three minutes and recheck the engine oil dipstick.

NOTICE

Do not fill the engine oil above the upper mark. Overfilling the engine oil can result in leaks and engine damage.

■ Resetting the Engine Oil Life

If you change or replace the vehicle's engine oil yourself, you must reset the engine oil life.

Models with information display

1. Press the select/reset knob until the engine oil life appears in the display.
2. Press and hold the knob for 10 seconds or more, until the display begins to blink.
3. Press and hold the knob for 5 seconds or more. The engine oil life display returns to 100%.

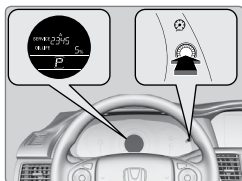

Models with multi-information display

Use the Info (▲/▼) and SEL/RESET buttons on the steering wheel buttons to control the display.

1. Scroll to the Vehicle Settings screen, and select it.
2. Scroll to the Maintenance Reset screen, and select it.
3. Select Reset. The maintenance codes disappear, and the engine oil life display returns to 100%.

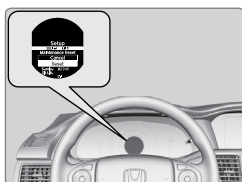

NOTICE

Failure to reset the Maintenance Minder display after a maintenance service results in the system showing incorrect maintenance intervals, which can lead to serious mechanical problems.

Engine Coolant

Park the vehicle on level ground. Check the reserve tank and the coolant level in the radiator. **We recommend Honda Long Life Antifreeze/Coolant Type 2.**

■ Checking the Reserve Tank

1. Check the amount of coolant in the reserve tank.
2. If the coolant level is below the MIN mark, add the specified coolant until it reaches the MAX mark.
3. Inspect the cooling system for leaks.

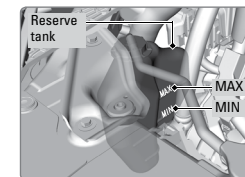

NOTICE

If temperatures consistently below -22°F (-30°C) are expected, the coolant mixture should be changed to a higher concentration. Consult a dealer for details for more information.

■ Adding Coolant

1. Make sure the engine and radiator are cool.
2. Turn the radiator cap counterclockwise and relieve any pressure in the coolant system. Do not push the cap down when turning.
3. Push down and turn the radiator cap counterclockwise to remove it.
4. The coolant level should be up to the base of the filler neck. Add coolant if it is low.
5. Put the radiator cap back on, and tighten it fully.
6. Pour coolant into the reserve tank until it reaches the MAX mark. Put the cap back on the reserve tank.

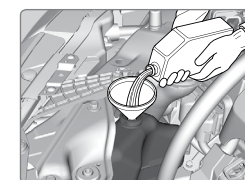
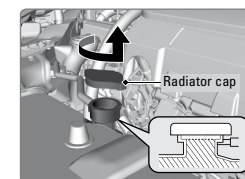

⚠ WARNING

Removing the radiator cap while the engine is hot can cause the coolant to spray out, seriously scalding you.

Always let the engine and radiator cool down before removing the radiator cap.

NOTICE

Pour the fluid slowly and carefully so you do not spill any. Clean up any spills immediately; they can damage components in the engine compartment.

Brake Fluid

The fluid level should be between the MIN and MAX marks on the side of the reserve tank. **We recommend using Honda Heavy Duty Brake Fluid DOT 3.**

Pour the fluid carefully.

If the fluid level is at or below the MIN mark, have a dealer inspect for leaks or worn brake pads as soon as possible.

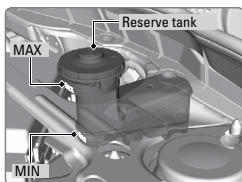

NOTICE

Brake fluid marked DOT 5 is not compatible with your vehicle's braking system and can cause extensive damage.

Clutch Fluid*

The fluid level should be between the MIN and MAX marks on the side of the reservoir. **We recommend using Honda Heavy Duty Brake Fluid DOT 3.**

Pour the fluid carefully.

If the fluid level is at or below the MIN mark, have a dealer inspect for leaks or an excessively worn clutch plate as soon as possible.

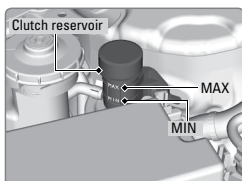

*if equipped

Checking the Battery

Check the battery terminals for corrosion monthly.

The battery condition is monitored by a sensor on the negative terminal. If there is a problem with the sensor, a message on the information display*/multi-information display* appears. Have your vehicle checked by a dealer.

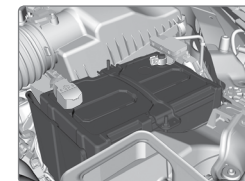

WARNING

The battery gives off explosive hydrogen gas during normal operation.

A spark or flame can cause the battery to explode with enough force to kill or seriously hurt you.

When conducting any battery maintenance, wear protective clothing and a face shield, or have a skilled technician do it.

WARNING: Battery posts, terminals, and related accessories contain lead and lead compounds. **Wash your hands after handling.**

Window Washer Fluid

If the washer fluid level is low, fill the washer reservoir. Pour the washer fluid carefully. Do not overflow the reservoir.

Canadian models

If the washer fluid level is low, the washer level indicator or a message appears on the multi-information display.

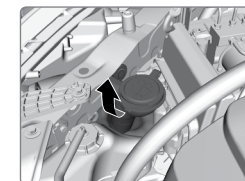

NOTICE

Do not use engine antifreeze or a vinegar/water solution in the windshield washer reservoir. Antifreeze can damage your vehicle's paint. A vinegar/water solution can damage the windshield washer pump.

*if equipped

Changing Wiper Blades

If the wiper blades leave streaks across the windshield, try cleaning them first with a paper towel or soft cloth and wiper fluid. If the wiper blade rubber has deteriorated, you should change the wiper blades.

1. Lift the driver side wiper arm first, then the passenger side.
2. Press and hold the tab, then slide the holder from the wiper arm.
3. Slide the wiper blade out from its holder by pulling the tabbed end out.
4. Remove the retainers from the rubber blade that has been removed, and mount to a new rubber blade. Correctly align the rubber protrusion and the retainer grooves.
5. Slide the new wiper blade onto the holder from the bottom end. The tab on the holder should fit in the indent of the wiper blade.
6. Slide the wiper holder onto the wiper arm, then push down the lock tab.
7. Lower the passenger side wiper arm first, then the driver side.

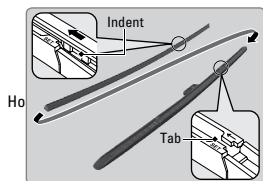
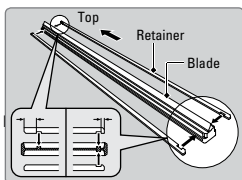
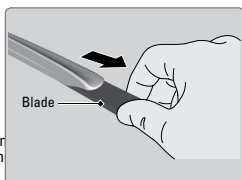
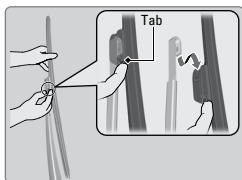
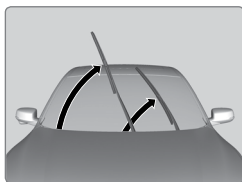

NOTICE

Avoid dropping the wiper arm, as it may damage the windshield.

Tire Information

To safely operate your vehicle, your tires must be of the proper type and size, in good condition with adequate tread, and properly inflated.

Inflation Guidelines

- Properly inflated tires provide the best combination of handling, tread life, and comfort. Refer to the driver's doorjamb label or the specifications (see page 148) for the specified pressure.
- Underinflated tires wear unevenly, adversely affect handling and fuel economy, and are more likely to fail from overheating.
- Overinflated tires make your vehicle ride harshly, are more prone to road hazards, and wear unevenly.
- Every day before you drive, look at each of the tires. If one looks lower than the others, check the pressure with a tire gauge.
- Measure the air pressure when tires are cold. This means the vehicle has been parked for at least 3 hours, or driven less than 1 mile (1.6 km). If necessary, add or release air until the specified pressure is reached, and then calibrate the system (see page 121). If checked when hot, tire pressure can be as much as 4–6 psi (30–40 kPa, 0.3–0.5 kgf/cm²) higher than checked when cold.
- At least once a month or before long trips, use a gauge to measure the pressure in all tires, including the spare. Even tires in good condition can lose 1–2 psi (10–20 kPa, 0.1–0.2 kgf/cm²) per month.

Inspection Guidelines

Every time you inflate the tires, check for the following:

- Any damage to tires, including bumps, bulges, cuts, splits, or cracks in the side or tread. Remove any foreign objects and inspect for air leaks. Replace tires if you see fabric or cord.
- Uneven or excessive tread wear. Have a dealer check the wheel alignment.
- Cracks or other damage around the valve stems.

Wear Indicators

The groove where the wear indicator is located is 1/16 inch (1.6 mm) shallower than elsewhere on the tire. If the tread has worn so low that the indicator is exposed, replace the tire. **Worn out tires have poor traction on wet roads.**

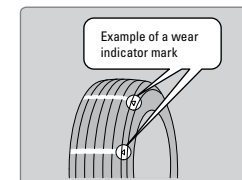

TABLE OF CONTENTS

VISUAL INDEX

SAFETY INFORMATION

INSTRUMENT PANEL

VEHICLE CONTROLS

AUDIO AND CONNECTIVITY

BLUETOOTH® HANDSFREELINK®

HONDALINK®

NAVIGATION

DRIVING

HANDLING THE UNEXPECTED

MAINTENANCE

SPECIFICATIONS

CUSTOMER INFORMATION

VOICE COMMAND INDEX

INDEX

⚠ WARNING

Using tires that are excessively worn or improperly inflated can cause a crash in which you can be seriously hurt or killed.

Follow all instructions in this owner's manual regarding tire inflation and maintenance.

Tire and Loading Information Label

The label attached to the driver's doorjamb provides necessary tire and loading information.

The diagram shows a rectangular label titled "TIRE AND LOADING INFORMATION". It includes a tire icon, a seating capacity section, and a table of tire specifications. Callout lines point from text labels to specific parts of the label: "Original tire sizes" points to the "TIRE SIZE" column; "Number of people your vehicle can carry" points to the "SEATING CAPACITY" section; "Proper cold tire pressure" points to the "COLD TIRE PRESSURE" column; and "Total weight your vehicle can carry (do not exceed)" points to the "TOTAL X" section.

TIRE	SIZE	COLD TIRE PRESSURE	SEE OWNER'S MANUAL FOR ADDITIONAL INFORMATION
FRONT	XXXX/XXXX XXX	XXXKPA, XXPSI	
REAR	XXXX/XXXX XXX	XXXKPA, XXPSI	
SPARE	XXXX/XXXX XXX	XXXKPA, XXPSI	

Tire and Wheel Replacement

Replace your tires with radials of the same size, load range, speed rating, and maximum cold tire pressure rating (as shown on the tire's sidewall). Using tires of a different size or construction can cause certain vehicle systems to work incorrectly. It is best to replace all four tires at the same time. If that isn't possible, replace the front or rear tires in pairs.

If you change or replace a wheel, make sure that the wheel's specifications match those of the original wheels. Only use TPMS-specified wheels approved for your vehicle.

⚠ WARNING

Installing improper tires on your vehicle can affect handling and stability. This can cause a crash in which you can be seriously hurt or killed. Always use the size and type of tires recommended in the Owner's Manual.

Tire Service Life

The life of your tires is dependent on many factors, including driving habits, road conditions, vehicle loading, inflation pressure, maintenance history, speed, and environmental conditions (even when the tires are not in use).

In addition to regular inspections and inflation pressure maintenance, it is recommended that you have annual inspections performed once the tires reach five years old. All tires, including the spare, should be removed from service after 10 years from the date of manufacture, regardless of their condition or state of wear.

Winter Tires

If driving on snowy or frozen roads, mount all season tires marked "M+S", snow tires, or tire chains; reduce speed; and maintain sufficient distance between vehicles when driving. For winter tires, select the size and load ranges that are the same as the original tires, and mount them to all four wheels.

Tire Chains

Install tire chains on the front tires only. Because your vehicle has limited tire clearance, we strongly recommend using the following chains:

- For 205/65R16 tires:**
Cable-type: SCC Radial Chain SC1034
- For 215/55R17 tires:**
Cable-type: SCC Radial Chain SC1036
- For 235/40R19 tires:**
Cable-type: SCC Radial Chain SC1040

Mount chains as tightly as you can, and make sure that they do not touch the brake lines or suspension.

NOTICE

Traction devices that are the wrong size or improperly installed can damage your vehicle's brake lines, suspension, body, and wheels. Stop driving if they are hitting any part of the vehicle.

⚠ WARNING

Using the wrong chains, or not properly installing chains, can damage the brake lines and cause a crash in which you can be seriously injured or killed. Follow all instructions in this guide regarding the selection and use of tire chains.

Tire Labeling

The tires that came on your vehicle have a number of markings. Those you should be aware of are described below.

Here is an example of what each marking means:

P215/55R17 94V

- P: vehicle type (passenger vehicle)
- 215: tire width in millimeters
- 55: aspect ratio (tire section height as a percentage of its width)
- R: tire construction code (radial)
- 17: rim diameter in inches
- 94: load index (code indicating maximum load tire can carry)
- V: speed symbol (code indicating maximum speed rating)

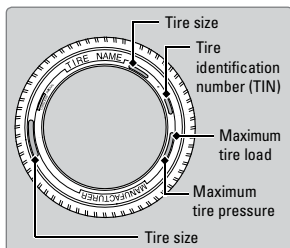

Tire Identification Number (TIN)

The tire identification number (TIN) is a group of numbers and letters that look like the example below. TIN is located on the sidewall of the tire.

DOT B97R FW6X 2209

DOT: This indicates that the tire meets all requirements of the U.S. Department of Transportation.

B97R: Manufacturer's identification mark

FW6X: Tire type code

22 09: Date of Transportation

Year
Week

Glossary of Tire Terminology

Cold Tire Pressure – The tire air pressure when the vehicle has been parked for at least three hours or driven less than 1 mile (1.6 km).

Load Rating – The maximum load that a tire is rated to carry for a given inflation pressure.

Maximum Inflation Pressure – The maximum tire air pressure that the tire can hold.

Maximum Load Rating – The load rating for a tire at the maximum permissible inflation pressure for that tire.

Recommended Inflation Pressure – The cold tire inflation pressure recommended by the manufacturer.

Treadwear Indicators (TWI) – The projections within the principal grooves designed to give a visual indication of the degrees of wear of the tread.

DOT Tire Quality Grading

The tires on your vehicle meet all U.S. Federal Safety Requirements. All tires are also graded for treadwear, traction, and temperature performance according to Department of Transportation (DOT) standards. The following explains these gradings.

Uniform Tire Quality Grading

Quality grades can be found where applicable on the tire sidewall between tread shoulder and maximum section width.

For example:

Treadwear 200
Traction AA
Temperature A

All passenger car tires must conform to Federal Safety Requirements in addition to these grades.

Treadwear

The treadwear grade is a comparative rating based on the wear rate of the tire when tested under controlled conditions on a specified government test course. For example, a tire graded 150 would wear one and one-half (1 1/2) times as well on the government course as a tire graded 100. The relative performance of tires depends upon the actual conditions of their use, however, and may depart significantly from the norm due to variations in driving habits, service practices, and differences in road characteristics and climate.

Traction

The traction grades, from highest to lowest, are AA, A, B, and C. Those grades represent the tire's ability to stop on wet pavement as measured under controlled conditions on specified government test surfaces of asphalt and concrete. A tire marked C may have poor traction performance.

WARNING: The traction grade assigned to this tire is based on straight-ahead braking traction tests, and does not include acceleration, cornering, hydroplaning, or peak traction characteristics.

■ Temperature

The temperature grades are A (the highest), B, and C, representing the tire's resistance to the generation of heat and its ability to dissipate heat when tested under controlled conditions on a specified indoor laboratory test wheel. Sustained high temperature can cause the material of the tire to degenerate and reduce tire life, and excessive temperature can lead to sudden tire failure. The grade C corresponds to a level of performance which all passenger car tires must meet under the Federal Motor Vehicle Safety Standard No. 109. Grades B and A represent higher levels of performance on the laboratory test wheel than the minimum required by law.

WARNING: The temperature grade for this tire is established for a tire that is properly inflated and not overloaded. Excessive speed, underinflation, or excessive loading, either separately or in combination, can cause heat buildup and possible tire failure.

Testing of Readiness Codes

Your vehicle has readiness codes as part of the onboard self-diagnostic system. Some states use these codes for testing to verify whether your vehicle's emissions components are working properly. The codes may not be read if you go through the testing just after the battery has gone dead or been disconnected.

To check if they are set, turn the vehicle on without starting the engine. The malfunction indicator lamp will come on for several seconds. If it goes off, the readiness codes are set. If it blinks five times, the readiness codes are not set.

If you are required to have your vehicle tested before the readiness codes are set, prepare the vehicle for retesting by doing the following:

1. Fill the gas tank to approximately 3/4 full.
2. Park the vehicle and leave the engine off for 6 hours or more.
3. Make sure the ambient temperature is between 40°F and 95°F (4°C and 35°C).
4. Start the engine without touching the accelerator pedal, and let it idle for 20 seconds.
5. Keep the vehicle in Park (P) or Neutral for manual transmission. Increase the engine speed to 2,000 rpm, and hold it there for about 3 minutes.
6. Let the engine idle with your foot off the accelerator for 20 seconds.
7. Select a nearby, lightly traveled major highway where you can maintain a speed of 50 to 60 mph (80 to 97 km/h) for at least 20 minutes. Drive on the highway with the vehicle in Drive (D) or 5th gear. Do not use cruise control. When traffic allows, drive for 90 seconds without using the accelerator pedal. (Vehicle speed may vary slightly; this is OK.) If you cannot do this for a continuous 90 seconds because of traffic conditions, drive for at least 30 seconds, then repeat two more times (for a total of 90 seconds).
8. Drive in city or suburban traffic for at least 10 minutes. When traffic conditions allow, let the vehicle coast for several seconds without using the accelerator pedal or the brake pedal.
9. Park the vehicle and leave the engine off for 30 minutes.

The readiness codes are erased when the battery is disconnected, and set again only after several days of driving under a variety of conditions.

If a testing facility determines that the readiness codes are not set, you may be requested to return at a later date to complete the test, or see your dealer.

SPECIFICATIONS

4-cylinder models

■ Vehicle

Model	Honda Accord Sedan
No. of Passengers:	
Front	2
Rear	3
Total	5
Weights:	
Gross Vehicle	U.S.: 4,200 lbs (1,905 kg) ^{*1}
Weight Rating	4,321 lbs (1,960 kg) ^{*2}
	Canada: 1,930 kg ^{*1}
	1,980 kg ^{*2}
Gross Axle Weight Rating (Front)	U.S.: 2,249 lbs (1,020 kg) ^{*1}
	2,315 lbs (1,050 kg) ^{*2}
	Canada: 1,030 kg ^{*1}
	1,065 kg ^{*2}
Gross Axle Weight Rating (Rear)	U.S.: 2,006 lbs (910 kg) ^{*1}
	2,050 lbs (930 kg) ^{*2}
	Canada: 910 kg ^{*1}
	930 kg ^{*2}
Air Conditioning:	
Refrigerant Type	HFC-134a (R-134a)
Charge Quantity	15.0 – 16.8 oz (425 – 475 g)
Lubricant Type	ND-OIL 8
Quantity	4.3 – 5.0 cu-in (70 – 82 cm ³)

*1: LX models

*2: Except LX models

■ Engine and Fuel

Engine	
Displacement	144 cu-in (2,356 cm ³)
Spark Plugs	NGK DILKAR7G11GS DILKAR7H11GS
	DENSO DXE22HQR-D11S

Fuel	
Fuel:	Unleaded gasoline
Type	Pump octane number of 87 or higher
Fuel Tank Capacity	17.2 US gal (65 ℓ)

■ Light Bulbs

Headlights (Low Beam)	55W (H11) ^{*1} LED ^{*2}
Headlights (High Beam)	60W (HB3) ^{*1} LED ^{*2}
Fog Lights*	LED
Front Turn Signal/Side Marker/Parking Lights ^{*1, *3}	28/8W (Amber)
Front Turn Signal/Side Marker Lights ^{*1, *4}	
Parking/Daytime Running Lights ^{*4}	LED
Front Turn Signal Lights ^{*2}	LED
Front Side Marker Lights ^{*2}	3CP
Side Turn Signal Lights (on Door Mirrors)*	LED
Brake Lights	21W ^{*5} LED ^{*6}
Rear Turn Signal Lights	21W (Amber)
Rear Side Marker Lights	LED
Taillights (on Fenders)	LED
Back-Up Lights	16W
Taillights (on Trunk Lid)	LED
High-Mount Brake Light	LED
Rear License Plate Lights	5W
Trunk Light	5W
Interior Lights	
Map Lights	8W
Ceiling Light	8W
Vanity Mirror Lights	1.4W
Courtesy Lights*	2CP

*1: Models with halogen headlights

*2: Models with LED headlights

*3: Models with bulb type parking lights

*4: Models with LED type parking/daytime running lights

*5: Models with bulb type brake lights

*6: Models with LED type brake lights

■ Tires

Regular	Size	205/65R16 95H ^{*1} 215/55R17 94V ^{*2} 235/40R19 96V ^{*3}
	Pressure psi (kPa [kgf/cm ²])	
	Front	33 (230 [2.3]) ^{*1, *3} 33 (225 [2.3]) ^{*2}
Rear	32 (220 [2.2]) ^{*1, *3} 33 (225 [2.3]) ^{*2}	
Compact Spare	Size	T135/90D16 102M ^{*1, *2} T135/80D17 103M ^{*3}
	Pressure psi (kPa [kgf/cm ²])	60 (420 [4.2])
Wheel Size	Regular	16 x 7J ^{*1} 17 x 7 1/2J ^{*2} 19 x 8J ^{*3}
	Compact Spare	16 x 4T ^{*1, *2} 17 x 4T ^{*3}

*1: U.S. LX models

*2: U.S. EX, EX-L models and Canadian LX, EX-L models

*3: U.S. Sport models and Canadian Sport, Touring models

4-cylinder models (continued)

■ Fluids

Engine Oil

Recommended	-Genuine Honda Motor Oil 0W-20	
	-API Premium-grade 0W-20 detergent oil	
Capacity	Change	4.2 US qt (4.0 ℓ)
	Change including filter	4.4 US qt (4.2 ℓ)

Engine Coolant

Specified	Honda Long-Life Antifreeze/Coolant Type2	
Ratio	50/50 with distilled water	
Capacity	1.66 US gal (6.28 ℓ) ^{*1}	
	1.66 US gal (6.30 ℓ) ^{*2}	
	(change including the remaining 0.17 US gal (0.64 ℓ) in the reserve tank)	

*1: Continuously variable transmission (CVT) models

*2: Manual transmission models

Brake/Clutch Fluid

Specified	Honda Heavy Duty Brake Fluid DOT 3
-----------	------------------------------------

Continuously Variable Transmission (CVT) Fluid

Specified	HCF-2
Capacity	Change 3.9 US qt (3.7 ℓ)

Manual Transmission Fluid

Specified	Honda Manual Transmission Fluid
Capacity	Change 2.0 US qt (1.9 ℓ)

Washer Fluid

Tank Capacity	U.S.: 2.6 US qt (2.5 ℓ) Canada: 4.85 ℓ
---------------	---

6-cylinder models

■ Vehicle

Model	Honda Accord Sedan
No. of Passengers:	
Front	2
Rear	3
Total	5
Weights:	
Gross Vehicle	U.S.: 4,542 lbs (2,060 kg)
Weight Rating	Canada: 2,060 kg
Gross Axle Weight Rating (Front)	U.S.: 2,491 lbs (1,130 kg) Canada: 1,130 kg
Gross Axle Weight Rating (Rear)	U.S.: 2,072 lbs (940 kg) Canada: 940 kg
Air Conditioning:	
Refrigerant Type	HFC-134a (R-134a)
Charge Quantity	15.0 – 16.8 oz (425 – 475 g)
Lubricant Type	ND-OIL 8
Quantity	4.3 – 5.0 cu-in (70 – 82 cm ³)

■ Engine and Fuel

Engine	
Displacement	212 cu-in (3,471 cm ³)
Spark Plugs	NGK ILZKR7B11 DENSO SXU22HCR11
Fuel	
Fuel:	Unleaded gasoline
Type	Pump octane number of 87 or higher
Fuel Tank Capacity	17.2 US gal (65 ℓ)

■ Tires

Regular	Size	215/55R17 94V ^{*1} 235/40R19 96V ^{*2}
	Pressure psi (kPa [kgf/cm ²])	
	Front	33 (225 [2.3]) ^{*1} 33 (230 [2.3]) ^{*2}
	Rear	33 (225 [2.3]) ^{*1} 32 (220 [2.2]) ^{*2}
Compact Spare	Size	T135/90D16 102M ^{*1} T135/80D17 103M ^{*2}
	Pressure psi (kPa [kgf/cm ²])	60 (420 [4.2])
Wheel Size	Regular	17 x 7 1/2J ^{*1} 19 x 8J ^{*2}
	Compact Spare	16 x 4T ^{*1} 17 x 4T ^{*2}

*1: EX-L V6 models

*2: U.S. Touring models and Canadian V6 Touring models

■ Light Bulbs

Headlights (Low Beam)	55W (H11) ^{*1} LED ^{*2}
Headlights (High Beam)	60W (HB3) ^{*1} LED ^{*2}
Fog Lights	LED
Front Turn Signal/Side Marker/Parking Lights ^{*1, *3}	28/8W (Amber)
Front Turn Signal/Side Marker Lights ^{*1, *4}	
Parking/Daytime Running Lights ^{*4}	LED
Front Turn Signal Lights ^{*2}	LED
Front Side Marker Lights ^{*2}	3CP
Side Turn Signal Lights (on Door Mirrors)	LED
Brake Lights	21W ^{*5} LED ^{*6}
Rear Turn Signal Lights	21W (Amber)
Rear Side Marker Lights	LED
Taillights (on Fenders)	LED
Back-Up Lights	16W
Taillights (on Trunk Lid)	LED
High-Mount Brake Light	LED
Rear License Plate Lights	5W
Trunk Light	5W
Interior Lights	
Map Lights	8W
Ceiling Light	8W
Vanity Mirror Lights	1.4W
Courtesy Lights	2CP

*1: Models with halogen headlights

*2: Models with LED headlights

*3: Models with bulb type parking lights

*4: Models with LED type parking/daytime running lights

*5: Models with bulb type brake lights

*6: Models with LED type brake lights

■ Fluids

Engine Oil

Recommended	Genuine Honda Motor Oil 0W-20 API Premium-grade 0W-20 detergent oil
	Change 4.2 US qt (4.0 ℓ)
Capacity	Change including filter 4.5 US qt (4.3 ℓ)

Engine Coolant

Specified	Honda Long-Life Antifreeze/Coolant Type2
Ratio	50/50 with distilled water
Capacity	1.72 US gal (6.5 ℓ)
	(change including the remaining 0.17 US gal (0.64 ℓ) in the reserve tank)

Brake Fluid

Specified	Honda Heavy Duty Brake Fluid DOT 3
-----------	------------------------------------

Automatic Transmission Fluid

Specified	Honda ATF DW-1 (automatic transmission fluid)
Capacity	Change 3.3 US qt (3.1 ℓ)

Washer Fluid

Tank Capacity	U.S.: 2.6 US qt (2.5 ℓ) Canada: 4.85 ℓ
---------------	---

CUSTOMER INFORMATION

Learn about information specific to you as a Honda customer and how to get help.

Frequently Asked Questions/Troubleshooting

Below are some frequently asked questions and troubleshooting items that you may have about the vehicle.

Q: *How do I set the vehicle clock?***A:** For vehicles without navigation, see page 49. For vehicles with navigation, the time is automatically set using GPS signals.**Q:** *Why doesn't the vehicle start when I press the ENGINE START/STOP button?****A:** The brake pedal (and/or clutch pedal*) must be pressed to start the engine.**Q:** *What is the AUTO setting on my headlight lever?***A:** When in the AUTO position, the vehicle's exterior lights will automatically turn on or off depending on the ambient lighting.**Q:** *Why won't the driver's door unlock when I grab the door handle, even though the keyless access remote is within range?****A:** If you pull the handle too quickly, the system may not have time to confirm the door is unlocked. Wait to hear a beep to confirm the door is unlocked. If you are wearing gloves, the system may be slow to respond.**Q:** *After my battery was disconnected or went dead, the audio system is asking for a code. Where do I find this?***A:** In most cases, you do not need to enter a code. Turn on the vehicle and the audio system, and press and hold the power button until the system reactivates.**Q:** *Why can't I operate Pandora through the audio system?****A:** Audio may be streaming through *Bluetooth* Audio. Make sure Pandora mode is selected and the phone cable is properly connected to the USB adapter cable (if using). Some phones may prompt you to "Allow" a connection.**Q:** *Is my phone compatible with Bluetooth features?***A:** Visit handsfreelink.com (U.S.) or www.handsfreelink.ca (Canada) to check phone compatibility for *Bluetooth* Audio, *Bluetooth* HandsFreeLink, and SMS text messaging.**Q:** *The amber indicator with a tire and exclamation mark is on. What does it mean?***A:** Your tire pressure is low or you are driving on the spare tire. See page 121.

*if equipped

Contact Us

Honda dealer personnel are trained professionals. They should be able to answer all your questions. If you encounter a problem that your dealership does not solve to your satisfaction, please discuss it with the dealership's service manager or general manager. If you are dissatisfied with the decision made by the dealership's management, contact Honda Automobile Customer Service.

U.S. owners

American Honda Motor Co., Inc.
Honda Automobile Customer Service
1919 Torrance Blvd.
Mail Stop 500-2N-7A
Torrance, CA 90501-2746
Tel: (800) 999-1009

In Puerto Rico and the U.S. Virgin Islands

Bella International
P.O. Box 190816
San Juan, PR 00919-0816
Tel: (787) 620-7546

Canadian owners

Honda Canada, Inc.
Customer Relations
180 Honda Blvd.
Markham, ON
L6C 0H9
Tel: (888) 946-6329
Fax: (877) 939-0909
e-mail: honda_cr@ch.honda.com

When you call or write, please give us the following information:

- Vehicle Identification Number
- Date of purchase
- Odometer reading of your vehicle
- Your name, address, and telephone number
- A detailed description of the problem
- Name of the dealer who sold the vehicle to you

Honda Roadside Assistance

24-hour emergency road service is available to you in the United States and Canada throughout your 3-year/36,000-mile warranty term. Services include jump starting, flat tire and lockout assistance, towing, and more (limitations apply). Call (866) 864-5211 (U.S.) or (800) 465-7587 (Canada).

*if equipped

Warranty Coverages

Below is a brief summary of the warranties covering your new vehicle.

New Vehicle Limited Warranty: Covers your new vehicle, except for the emissions control system and accessories, against defects in materials and workmanship.

Emissions Control Systems Defects Warranty and Emissions Performance Warranty: Covers your vehicle's emissions control systems. Time, mileage, and coverage are conditional.

Seat Belt Limited Warranty: Covers seat belts that fail to function properly.

Rust Perforation Limited Warranty: Covers all exterior body panels that rust through from the inside.

Accessory Limited Warranty: Covers Honda accessories.

Replacement Parts Limited Warranty: Covers all Honda replacement parts against defects in materials and workmanship.

Replacement Battery Limited Warranty: Provides prorated coverage for a replacement battery purchased from a Honda dealer.

Replacement Muffler Lifetime Limited Warranty: Covers a replacement muffler for the duration of the ownership.

Restrictions and exclusions apply to all these warranties. See the Warranty Manual on the Owner Information CD or at owners.honda.com (U.S.) or myhonda.ca (Canada) for complete descriptions of each warranty, including time, mileage, and other conditional limitations.

Your vehicle's original tires are covered by their manufacturer. Tire warranty information can be found on the Owner Information CD or at owners.honda.com (U.S.) or myhonda.ca (Canada).

EPA Contact Information

An owner may obtain further information concerning emission warranties or report violations of the terms of the emission warranties by contacting:

U.S. Environmental Protection Agency
Office of Transportation and Air Quality
Compliance Division,
Light-Duty Vehicles Group
Attn: Warranty Complaints
2000 Traverwood Drive
Ann Arbor, MI 48105
Email: complianceinfo@epa.gov

VOICE COMMAND INDEX

Available on vehicles with touchscreen. Learn about the available voice commands to help you operate the vehicle. The system recognizes only those commands shown here. Press the Talk button before you say a command.

Voice Portal Commands

When you press the Talk button, the Voice Portal screen appears. Say one of the options, and follow the system prompts.

- Phone call
- Music search
- Audio
- Climate control
- Navigation*
- Voice setting
- Voice help
- What is today's date?
- What time is it?

Navigation Commands*

The system accepts these commands on most screens. You only need to press the Talk button once for navigation commands.

- View map
- Find place
- Find category
- Find intersection
- Recently found
- Go home
- Find address
- Find city
- Find saved places
- Detour
- Stop route

Climate Control Commands

The system accepts these commands on most screens.

- Climate control on**
- Climate control off**
- Air conditioner on**
- Air conditioner off**
- Defrost on**
- Defrost off**
- Fan speed # (#: 1 to 7)
- Temperature # degrees (#: 57 to 87°F)
- Temperature max heat
- Temperature max cool

Phone Commands

The system accepts these commands on most screens. Not available during use of Apple CarPlay or Android Auto.

- Call by number
- Call by name
- Call (number)
- Call (name)

**models with navigation*

***These commands toggle the function on and off, so the command may not match your intended action.*

Audio Commands*

The system accepts these commands on most screens. Audio volume levels cannot be controlled using voice commands.

FM/AM Radio Commands

- Audio on**
- Audio off**
- Radio FM
- Radio AM
- Radio tune to # FM (#: frequency, e.g., 95.5)
- Radio tune to # AM (#: frequency, e.g., 1020)
- Radio FM preset # (#: 1 to 12)
- Radio AM preset # (#: 1 to 6)

SiriusXM Radio Commands

- Radio SXM
- SXM channel # (#: 0 to 255)
- SXM channel (channel name)
- Radio SXM preset # (#: 1 to 12)

Pandora Commands (U.S. only)***

- Pandora
- Pandora play

Song By Voice Commands***

Available for tracks stored on an iPod or USB device.

- Music search
- List album (specify album)
- List artist (specify artist)
- List composer (specify composer)
- List genre (specify genre)
- List playlist (specify playlist)
- Play album (specify album)
- Play artist (specify artist)
- Play composer (specify composer)
- Play genre (specify genre)
- Play playlist (specify playlist)
- Play song (specify song)
- What/Who am I listening to?
- Who is this?
- What's playing?
- Who's playing?
- What album is this?

Disc (CD) Commands

- Disc
- Disc play
- Disc play track # (#: 1 to 30)

USB Commands***

- USB
- USB play
- USB play track # (#: 1 to 30)

iPod Commands***

- iPod
- iPod play
- iPod play track # (#: 1-30)

Bluetooth Audio Commands

- Bluetooth audio play
(may not work on all phones)

AUX Commands

- Aux audio play

**models with navigation*

***These commands toggle the function on and off, so the command may not match your intended action.*

****Not available during use of Apple CarPlay.*

INDEX

ABS.....	24
ACC.....	24, 26
Accessory Power Socket.....	50
Adaptive Cruise Control (ACC).....	24, 107
Address.....	89
Advanced Airbags.....	8
Aha™ Radio.....	64
Airbags.....	8
Airbag Care.....	13
Airbag System Components.....	12
Airbag System Indicators.....	10
Ambient Meter.....	105
Android Auto.....	66
Anti-Lock Brake System (ABS).....	24, 104
Apple CarPlay™.....	65
Apps.....	62
Audio Commands.....	155
Audio Operation.....	50
Aha™ Radio.....	64
Android Auto.....	66
Apple CarPlay™.....	65
Auxiliary Input Jack.....	50
Bluetooth® Audio.....	59, 72
Compact Disc (CD).....	56, 69
FM/AM Radio.....	55, 67
HondaLink™.....	63
iPod®.....	57, 70
One Display Audio Operation.....	54
Pandora®.....	60, 73
SiriusXM® Radio.....	68
Sound.....	53
Steering Wheel Controls.....	52
Touchscreen Operation.....	61
USB Flash Drive.....	58, 71
USB Port.....	50
Wi-Fi Connection.....	64
Wireless Charger.....	51
Auto High-Beam System.....	24, 26, 36
Automatic Dimming Rearview Mirror.....	44
Automatic Intermittent Wipers.....	38
AUX Commands.....	155
Auxiliary Input Jack.....	50
Battery.....	139
Bluetooth® Audio.....	59, 72
Bluetooth® Audio Commands.....	155
Bluetooth® Handsfreelink® (HFL).....	74
Call History.....	77, 83
Dialing a Number.....	76, 82
E-Mail.....	84
HFL Controls.....	74, 79
HondaLink™ Assist.....	85
Making a Call.....	76, 82
Pairing a Phone.....	75, 81
Phonebook.....	77, 83
Siri Eyes Free.....	86
SMS Text Messaging.....	78, 84
Speed Dial.....	76, 82
Talk Button Tips.....	80
Brake Assist System.....	104
Brake Fluid.....	138
Brake system.....	23, 24
Braking.....	104
Brightness Control.....	35
Call History.....	77, 83
Carbon Monoxide Gas.....	4
Changing a Flat Tire.....	123
Changing Settings.....	48
Charging system.....	23
Childproof Door Locks.....	32
Child Safety.....	14
Child Seat.....	16
Adding Security with a Tether.....	19
LATCH-Compatible Child Seat.....	17
Climate Control Commands.....	154
Climate Control System.....	46
Clock.....	49
Clutch Fluid.....	138
CMBS™.....	26
Collision Mitigation Braking System™.....	24, 112
Compact Disc (CD).....	56, 69
Compact Disc (CD) Commands.....	155
Condition Indicators.....	25
Contact Us.....	152
Continuously Variable Transmission (CVT).....	101
Cruise Control.....	106
CRUISE CONTROL.....	26
CUSTOMER Information.....	151
Customized Features.....	48
Dashboard and Other Controls.....	2
Daytime Running Lights (DRL).....	24
Destination.....	89
Dialing a Number.....	76, 82
Door Mirrors.....	44
Door open.....	25
Door Operation.....	32
Doors.....	31
DOT Tire Quality Grading.....	145

Driving.....	94
Adaptive Cruise Control (ACC).....	107
Braking.....	104
Collision Mitigation Braking System.....	112
Continuously Variable Transmission (CVT).....	101
Cruise Control.....	106
Eco Assist System.....	105
ENGINE START/STOP button.....	101
Forward Collision Warning (FCW).....	109, 110, 112
Ignition.....	100
Lane Keeping Assist System (LKAS).....	110
LaneWatch™.....	111
Manual Transmission.....	103
Maximum Load Limit.....	96
Multi-View Rear Camera.....	114
Paddle Shifters.....	102
Parking Sensor System.....	113
Power Mode.....	101
Refueling.....	115
Remote Engine Start.....	99
Road Departure Mitigation (RDM).....	109
Shifting.....	101
Towing a Trailer.....	98
Vehicle Stability Assist (VSA®).....	105
Wiper Blades.....	140
Driving Position Memory System.....	43
Eco Assist System.....	105
ECON Button.....	105
ECON mode.....	26
Electric Power Steering (EPS).....	24
E-Mail.....	84
Emergency Engine Stop.....	120
Emergency Towing.....	120
Engine and Fuel.....	148, 150
Engine Coolant.....	137
Engine Oil.....	134
ENGINE START/STOP button.....	101
Exterior Lights.....	26, 35
Fastening a Seat Belt.....	7
Flat Tire.....	123
Floor Mats.....	40
Fluids.....	149, 150
FM/AM Radio.....	55, 67
FM/AM Radio Commands.....	155
Fog lights.....	26
Foot Brake.....	104
Frequently Asked Questions.....	151
Front Airbags (SRS).....	8
Front Door Inner Handle.....	32
Fuel Information.....	115
Fuse Locations.....	126
Garage Opener.....	45
Hazards.....	26
Headlight-Wiper Integration.....	37
Head Restraints.....	41
High beams.....	26
High temperature.....	24
Home Address.....	89
HomeLink® Universal Transceiver.....	45
HondaLink™.....	63
HondaLink™ Assist.....	85
Honda Roadside Assistance.....	152
Hood.....	132
Ignition.....	100
Immobilizer.....	25
Information Display.....	27
Instrument Panel.....	23
Interior Lights.....	35
Intermittent Wipers.....	37
iPod®.....	57, 70
iPod® Commands.....	155
Jump Starting.....	117
Key.....	30
Lane Keeping Assist System (LKAS).....	25, 110
LaneWatch™.....	111
Lap/Shoulder Seat Belts.....	5
LATCH-Compatible Child Seat.....	17
Light Bulbs.....	148, 150
Light control.....	24
Lights.....	26, 35
LKAS.....	25, 26
Lock Tab.....	32
Low fuel.....	25
Low oil pressure.....	23
Low temperature.....	24
Low tire pressure.....	25
Maintenance.....	129
Battery.....	139
Brake Fluid.....	138
Clutch Fluid.....	138
Engine Coolant.....	137
Engine Oil.....	134
Maintenance Minder™.....	130
Service Codes.....	131
Under the Hood.....	132
Window Washer Fluid.....	139
Making a Call.....	76, 82
Malfunction indicator lamp.....	24
Malfunction Indicators.....	23
Manual Seats.....	40
Manual Transmission.....	103
Map Legend.....	92
Master Door Lock Switch.....	32
Maximum Load Limit.....	96
Mirrors.....	44
Moonroof.....	34
Multi-Information Display (MID).....	28
Multi-View Rear Camera.....	114
Music search.....	155

Navigation 87

 Display and Controls 88

 Entering a Destination 89

 Home Address 89

 Map Legend 92

 Place Category 90

 Recent Places 90

 Routing 92

 Saved Places 91

 Steering Wheel Controls 87

 Street Address 89

 System Guidance Volume 87

 Talk Button Tips 87

 Traffic 93

 Turn-by-turn directions 92

Navigation Commands 154

One Display Audio Operation 54

One-Touch Turn Signal 38

On/Off Indicators 26

Opening the Hood 133

Overheating 119

Paddle Shifters 102

Pairing a Phone 75, 81

Pandora® 60, 73

Pandora® Commands 155

Parking Brake 25, 104

Parking Sensor System 24, 113

Passenger Airbag Off Indicator 11

Phone 75, 81

Phonebook 77, 83

Phone Commands 154

Place Category 90

Power Door Mirrors 44

Power Mode 101

Power Moonroof Operation 34

Power Seats 39

Power Window Lock 33

Power Window Operation 33

Radio 67

Readiness Codes 147

Rear Camera 114

Rear Seats 42

Rearview Mirror 44

Recent Places 90

Refueling 115

Remote Battery Strength 116

Remote Engine Start 99

Remote Transmitter 30

Reporting Safety Defects 22

Road Departure Mitigation (RDM) 25, 109

Roadside Assistance 152

Routing 92

Safety Information 3

 Airbags 8

 Child Safety 14

 Reporting Safety Defects 22

 Safety Label Locations 21

 Safety Messages 3

 Seat Belts 5

Saved Places 91

Seat belt reminder 25

Seat Belts 5

 Fastening a Seat Belt 7

 Seat Belt Inspection 6

 Shoulder Anchor 7

Seat Heaters 47

Seats 39

SEL/RESET button 27, 29

Service Codes 131

SETTINGS Button 48

Setting the Clock 49

Shifting 101

Shift Lever Does Not Move 116

Shoulder Anchor 7

Side Airbags 9

Side Curtain Airbags 9

Siri Eyes Free 86

SiriusXM® Radio 68

SiriusXM® Radio Commands 155

Smart Entry System 23, 31

SMS Text Messaging 78, 84

Song By Voice™ Commands 155

Sound 53

Specifications 148

Speed Dial 76, 82

SRS (Supplemental Restraint) Indicator 10

Starter system 24

Steering Wheel 43

Steering Wheel and Nearby Controls 1

Steering Wheel Controls 52, 87

Street Address 89

Supplemental Restraint System (SRS) 23

System Guidance Volume 87

System message 25

Talk Button Tips 80, 87

Text Messaging 78, 84

Tire Information 141

 DOT Tire Quality Grading 145

 Inflation Guidelines 141

 Tire and Loading Information Label 142

 Tire and Wheel Replacement 142

 Tire Chains 143

 Tire Identification Number (TIN) 144

 Tire Labeling 144

 Tire Service Life 143

 Tire Terminology 144

 Wear Indicators 141

 Winter Tires 143

Tire Pressure Monitoring System (TPMS) 24, 121

Tires 148, 150

Touchscreen Operation 61

Towing 120

Towing a Trailer 98

TPMS 24, 121, 122

Traffic 93

Trip Computer 29

Troubleshooting 151

Trunk 31

Trunk Opener 32

Turn-by-turn directions 92

Turn signals 26, 38

Under the Hood 132

USB Commands 155

USB Flash Drive 58, 71

USB Port 50

Vehicle 148, 150

Vehicle Controls 30

Vehicle Settings 29

Vehicle Stability Assist (VSA®) 24, 105

Visual Index 1

Voice Command Index 154

Voice Portal Commands 154

Voice Recognition Tips 80

VSA® 24, 26

Warranty Coverages 153

Washer fluid level 25

Wear Indicators 141

Widgets 62

Wi-Fi Connection 64

Window 33

Window Washer Fluid 139

Winter Tires 143

Wiper Blades 140

Wiper Operation 37

Wireless Charger 51

TABLE OF CONTENTS

VISUAL INDEX

SAFETY INFORMATION

INSTRUMENT PANEL

VEHICLE CONTROLS

AUDIO AND CONNECTIVITY

BLUETOOTH® HANDSFREELINK®

HONDALINK®

NAVIGATION

DRIVING

HANDLING THE UNEXPECTED

MAINTENANCE

SPECIFICATIONS

CUSTOMER INFORMATION

VOICE COMMAND INDEX

INDEX



31T2AG10
OG-08654
00X31-T2A-G102

owners.honda.com (U.S.)
myhonda.ca (Canada)

2017 Honda Accord Sedan Owner's Guide
©2018 Honda Motor Co., Ltd. — All Rights Reserved

Printed in U.S.A.