



**CIVIC**

[owners.honda.com](http://owners.honda.com) (U.S.)  
[myhonda.ca](http://myhonda.ca) (Canada)

31TR3G00  
00X31-TR3-G000

2015 Honda Civic Owner's Guide  
©2014 Honda Motor Co., Ltd. — All Rights Reserved

Printed in U.S.A.



**2015**  
**OWNER'S GUIDE**

# DISCLOSURES

## ■ Devices That Emit Radio Waves

The following products and systems on your vehicle emit radio waves when in operation:

- Audio system
- Immobilizer system
- Bluetooth® Audio
- Remote transmitter
- Bluetooth® HandsFreeLink®

Each of the above complies with the appropriate requirements or the required standards of the FCC (Federal Communications Commission) and Industry Canada, described below:

*As required by the FCC:*

*This device complies with Part 15 of the FCC rules. Operation is subject to the following two conditions: (1) This device may not cause harmful interference, and (2) this device must accept any interference received, including interference that may cause undesired operation.*

*Changes or modifications not expressly approved by the party responsible for compliance could void the user's authority to operate the equipment.*

*As required by Industry Canada:*

*This device complies with Industry Canada Standard RSS-Gen/210/310. Operation is subject to the following two conditions: (1) this device may not cause interference, and (2) this device must accept any interference, including interference that may cause undesired operation of the device.*

## ■ California Perchlorate Contamination Prevention Act

The airbags, seat belt tensioners, and CR-type batteries in this vehicle may contain perchlorate materials—special handling may apply. See [www.dtsc.ca.gov/hazardouswaste/perchlorate/](http://www.dtsc.ca.gov/hazardouswaste/perchlorate/) for more information.

## ■ California Proposition 65 Warning

**WARNING:** This product contains or emits chemicals known to the state of California to cause cancer and birth defects or other reproductive harm.

## ■ Event Data Recorders

**This vehicle is equipped with an event data recorder (EDR).** The main purpose of an EDR is to record, in certain crash or near crash-like situations, such as an air bag deployment or hitting a road obstacle, data that will assist in understanding how a vehicle's systems performed. **The EDR is designed to record data related to vehicle dynamics and safety systems for a short period of time, typically 30 seconds or less. The EDR in this vehicle is designed to record such data as:**

- **How various systems in your vehicle were operating;**
- **Whether or not the driver and passenger safety belts were buckled/fastened;**
- **How far (if at all) the driver was depressing the accelerator and/or brake pedal; and,**
- **How fast the vehicle was traveling.**

These data can help provide a better understanding of the circumstances in which crashes and injuries occur. NOTE: EDR data are recorded by your vehicle only if a non-trivial crash situation occurs; no data are recorded by the EDR under normal driving conditions and no personal data (e.g., name, gender, age, and crash location) are recorded. However, other parties, such as law enforcement, could combine the EDR data with the type of personally identifying data routinely acquired during a crash investigation.

To read data recorded by an EDR, special equipment is required, and access to the vehicle or the EDR is needed. In addition to the vehicle manufacturer, other parties such as law enforcement that have the special equipment can read the information if they have access to the vehicle or the EDR.

The data belong to the vehicle owner and may not be accessed by anyone else except as legally required or with the permission of the vehicle owner.

## ■ Service Diagnostic Recorders

This vehicle is equipped with service-related devices that record information about powertrain performance. The data can be used to verify emissions law requirements and/or help technicians diagnose and solve service problems. It may also be combined with data from other sources for research purposes, but it remains confidential.

# INTRODUCTION

This Owner's Guide is intended to help you quickly get acquainted with your 2015 Honda Civic. It provides basic information and instructions on technology and convenience features, as well as emergency procedures and how to get assistance.

This guide is for vehicles sold in the United States and Canada. It covers all Civic Sedan, Coupe, and Natural Gas models, so you may find descriptions of features and equipment that are not in your vehicle. Images throughout this guide are from U.S. vehicles and represent features and equipment that are available on some, but not all, models.

This guide is not intended to be a substitute for the Owner's Manual. The Owner Information CD enclosed in your glove box kit includes the Owner's Manual, Navigation Manual, and vehicle and tire warranties in electronic format. This information can be viewed on a computer (PC or Mac platform) and saved or printed for your reference. You can also visit [owners.honda.com](http://owners.honda.com) (U.S.) or [myhonda.ca](http://myhonda.ca) (Canada) to view the complete and most current information.

If you are the first registered owner of your vehicle, you may request a complimentary printed copy of the Owner's Manual, Navigation Manual, or Vehicle Warranty within the first six months of vehicle purchase. To request a copy, visit [owners.honda.com](http://owners.honda.com) (U.S.) and create or log in to your account. In Canada, please request a copy from your Honda dealer.

American Honda Motor Company strives to be proactive in protecting our environment and natural resources. By using electronic delivery for a considerable portion of the information typically found in a vehicle owner's manual, we are further reducing our impact on the environment.

## Honda Automobile Customer Service

Your authorized Honda dealer should be able to answer any questions you have about your vehicle. However, if you are dissatisfied with the information you receive, you can call Honda Automobile Customer Service (see page 141).

**Call (800) 999-1009 (U.S.) or (888) 946-6329 (Canada)**

## Honda Roadside Assistance

24-hour emergency road service is available to you in the United States and Canada throughout your 3-year/36,000-mile warranty term. Services include jump starting, flat tire and lockout assistance, towing, and more (limitations apply).

**Call (866) 864-5211 (U.S.) or (800) 465-7587 (Canada)**

# TABLE OF CONTENTS

<b>VISUAL INDEX</b> .....	1
<b>Steering Wheel and Nearby Controls</b> ...	1
<b>Dashboard, Ceiling, and Other Controls</b> .....	2
<b>SAFETY INFORMATION</b> .....	3
<b>Important Safety Information</b> .....	3
<b>Seat Belts</b> .....	5
<b>Airbags</b> .....	8
<b>Child Safety</b> .....	14
<b>Safety Label Locations</b> .....	21
<b>Reporting Safety Defects</b> .....	22
<b>INSTRUMENT PANEL</b> .....	23
<b>Malfunction Indicators</b> .....	23
<b>Condition Indicators</b> .....	25
<b>Gauges</b> .....	26
<b>On/Off Indicators</b> .....	26
<b>Information Display*</b> .....	27
<b>Intelligent Multi-Information Display (i-MID)*</b> .....	28
<b>VEHICLE CONTROLS</b> .....	29
<b>Using the Remote Transmitter*</b> ....	29
<b>Smart Entry System*</b> .....	30
<b>Door Operation</b> .....	31
<b>Power Window Operation</b> .....	32
<b>Power Moonroof Operation*</b> .....	33
<b>Interior and Exterior Lights</b> .....	34
<b>One-Touch Turn Signal</b> .....	35
<b>Wiper Operation</b> .....	35
<b>Adjusting the Seats</b> .....	36
<b>Adjusting the Steering Wheel</b> .....	40
<b>Adjusting the Mirrors</b> .....	40
<b>Air Conditioning System*</b> .....	41
<b>Climate Control System*</b> .....	42
<b>Seat Heaters*</b> .....	42
<b>Customized Features*</b> .....	43
<b>Setting the Clock</b> .....	44
<b>AUDIO AND CONNECTIVITY</b> .....	45
<b>Basic Audio Operation</b> .....	45
<i>Models with information display</i>	
<b>FM/AM Radio</b> .....	48
<b>Compact Disc (CD)</b> .....	49
<i>Models with one display</i>	
<b>One Display Audio Operation</b> .....	50
<b>FM/AM Radio</b> .....	51
<b>Compact Disc (CD)</b> .....	52
<b>iPod®</b> .....	53
<b>USB Flash Drive</b> .....	54
<b>Bluetooth® Audio</b> .....	55
<b>Pandora®</b> .....	56
<i>Models with touchscreen</i>	
<b>Touchscreen Operation</b> .....	57
<b>HondaLink™</b> .....	58
<b>FM/AM Radio</b> .....	59
<b>SiriusXM® Radio</b> .....	60
<b>Compact Disc (CD)</b> .....	61
<b>iPod®</b> .....	62
<b>USB Flash Drive</b> .....	63
<b>Bluetooth® Audio</b> .....	64
<b>Pandora®</b> .....	65
<b>HDMI Video</b> .....	66
<b>BLUETOOTH® HANDSFREELINK® (HFL)...</b>	67
<i>Models with one display</i>	
<b>Basic HFL Operation</b> .....	67
<b>Pairing a Phone</b> .....	68
<b>Making a Call</b> .....	69
<b>SMS Text Messaging</b> .....	70

*Models with touchscreen*

**Basic HFL Operation**..... 71  
**Pairing a Phone**..... 73  
**Making a Call** ..... 74  
**SMS Text Messaging and E-Mail\***... 76  
**HondaLink™ Assist** ..... 77  
**Siri™ Eyes Free** ..... 77  
**NAVIGATION\*** ..... 78  
**Basic Navigation Operation** ..... 78  
**Entering a Destination** ..... 81  
**Routing**..... 83  
**DRIVING** ..... 85  
**Before Driving** ..... 85  
**Maximum Load Limit**..... 87  
**Towing a Trailer** ..... 89  
**Starting to Drive** ..... 90  
**Shifting**..... 91  
**Braking** ..... 93  
**Eco Assist System\***..... 94  
**Vehicle Stability Assist (VSA®), aka Electronic Stability Control (ESC) System**..... 94  
**Cruise Control\*** ..... 95  
**LaneWatch™\*** ..... 96  
**Rearview Camera\*** ..... 97  
**Multi-View Rear Camera\***..... 98  
**Refueling** ..... 99  
**HANDLING THE UNEXPECTED** ... 103  
**Smart Entry Remote Battery Strength**... 103  
**Jump Starting** ..... 103  
**Shift Lever Does Not Move\*** ..... 104  
**Overheating**..... 105

**Emergency Engine Stop\***..... 106  
**Emergency Towing** ..... 106  
**Tire Pressure Monitoring System (TPMS)\*** ..... 107  
**Changing a Flat Tire**..... 108  
**Tire Repair Kit\*** ..... 111  
**Fuse Locations**..... 112  
**MAINTENANCE** ..... 115  
**Safety Precautions** ..... 115  
**Maintenance Minder™** ..... 116  
**Under the Hood**..... 119  
**Engine Oil** ..... 121  
**Engine Coolant** ..... 124  
**Checking the Battery**..... 125  
**Window Washer Fluid** ..... 125  
**Changing Wiper Blades**..... 126  
**Tire Information**..... 127  
**Tire Labeling** ..... 130  
**DOT Tire Quality Grading**..... 131  
**Tire Pressure Monitoring System (TPMS) - Required Federal Explanation** ..... 133  
**Testing of Readiness Codes** ..... 134  
**SPECIFICATIONS** ..... 135  
**CUSTOMER INFORMATION**..... 140  
**Frequently Asked Questions/ Troubleshooting** ..... 140  
**Contact Us** ..... 141  
**Honda Roadside Assistance**..... 141  
**Warranty Coverages**..... 142  
**VOICE COMMAND INDEX**..... 143  
**INDEX** ..... 148

# VISUAL INDEX

Quickly locate items in the vehicle's interior.

## Steering Wheel and Nearby Controls

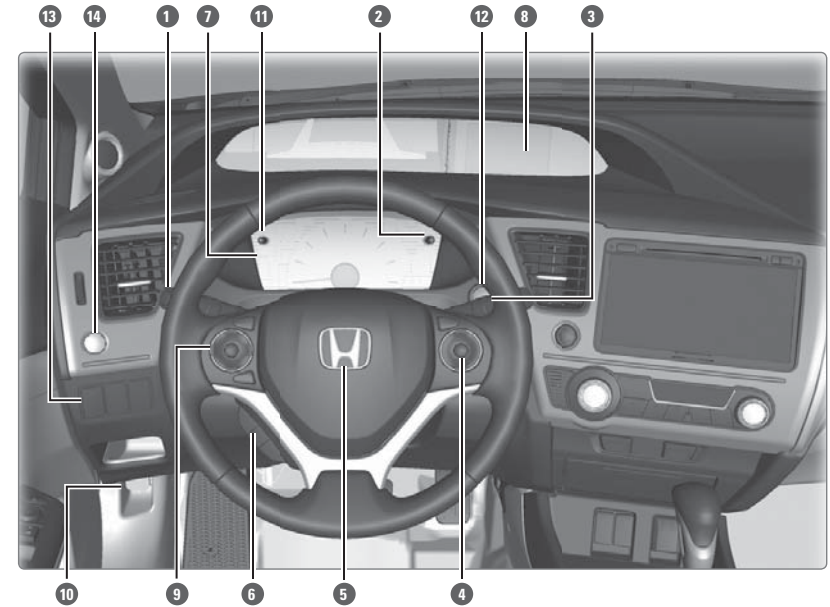

- 1 Lights/turn signals/LaneWatch button\* p. 34, p. 35, p. 96
- 2 SEL/RESET knob p. 28  
Brightness control p. 34
- 3 Wipers/washers p. 35
- 4 Cruise control buttons p. 95
- 5 Horn
- 6 Voice recognition buttons p. 67, p. 71, p. 78
- 7 Instrument panel p. 23
- 8 Information display\* p. 27  
intelligent Multi-Information Display (i-MID)\* p. 28
- 9 MENU button\*/SOURCE button\* p. 43, p. 46, p. 71, p. 78  
Audio controls p. 46  
i-MID button\* p. 28
- 10 Hood release handle p. 120
- 11 km/mile change knob  
CLOCK knob\* p. 44
- 12 ENGINE START/STOP button\* p. 91
- 13 Vehicle Stability Assist (VSA®) OFF button p. 94
- 14 ECON button\* p. 94

*\*if equipped*

*\*if equipped*



## Dashboard, Ceiling, and Other Controls

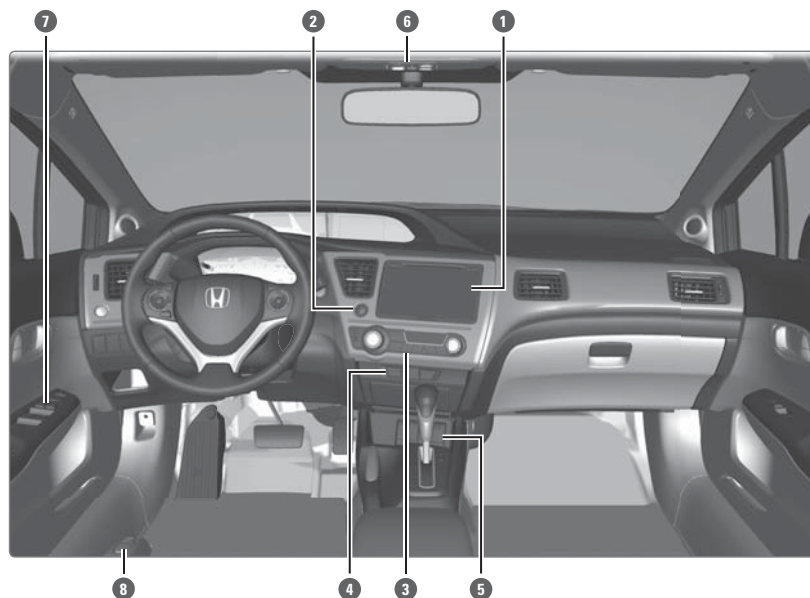

- |  |   |
|--|---|
| <p>1 Touchscreen* (audio/phone/navigation* controls) p. 57, p. 71, p. 79</p> <p>2 Hazard warning button</p> <p>3 Climate control system p. 41, p. 42</p> <p>4 Seat heater switches* p. 42</p> <p>5 USB/HDMI* port p. 45<br/>Auxiliary input jack* p. 45<br/>Accessory power socket p. 45</p> | <p>6 Moonroof switch* p. 33<br/>Map lights p. 34</p> <p>7 Power window switches p. 32<br/>Door lock switches p. 31<br/>Door mirror controls p. 40</p> <p>8 Fuel fill door handle p. 99<br/>Trunk release button p. 31</p> |
|--|---|

## SAFETY INFORMATION

Your safety—and the safety of others—is very important, and operating this vehicle safely is an important responsibility. While we strive to help you make informed decisions about safety, it is not practical or possible to warn you about all the hazards associated with operating or maintaining your vehicle. Therefore, you must use your own good judgment.

### Important Safety Information

This guide explains many of your vehicle's safety features and how to use them. Please read this information carefully. Following the instructions below will also help to keep you and your passengers safe.

#### ■ Important Safety Precautions

- Always wear your seat belt.
- Secure all children in the proper restraint system.
- Be aware of airbag hazards.
- Don't drink and drive.
- Pay appropriate attention to the task of driving safely.
- Control your speed.
- Keep your vehicle in safe condition.

Engaging in cell phone conversation or other activities that keep you from paying close attention to the road, other vehicles, and pedestrians could lead to a crash. Remember, situations can change quickly, and only you can decide when it is safe to divert some attention away from driving.

#### ■ Safety Messages

When you see the following messages throughout this guide, pay close attention.

**⚠ DANGER** You **WILL** be **KILLED** or **SERIOUSLY HURT** if you don't follow instructions.

**⚠ WARNING** You **CAN** be **KILLED** or **SERIOUSLY HURT** if you don't follow instructions.

**⚠ CAUTION** You **CAN** be **HURT** if you don't follow instructions.

**NOTICE** This information is intended to help you avoid damage to your vehicle, other property, or the environment.

*\*if equipped*

### ■ Carbon Monoxide Gas

The engine exhaust from this vehicle contains carbon monoxide, a colorless, odorless, and highly toxic gas. As long as you properly maintain your vehicle and follow the instructions set forth below, you will not accumulate dangerous levels of carbon monoxide gas in the vehicle interior.

Have the exhaust system inspected for leaks whenever:

- The exhaust system is making an unusual noise.
- The exhaust system may have been damaged.
- The vehicle is raised for an oil change.

When you operate a vehicle with the trunk open, airflow can pull exhaust gas into the interior and create a hazardous condition. If you must drive with the trunk open, open all the windows and set the climate control system as shown below.

1. Select the fresh air mode.
2. Select the  mode.
3. Set the fan speed to high.
4. Set the temperature control to a comfortable setting.

Adjust the climate control system in the same manner if you sit in your parked vehicle with the engine running.

#### **WARNING**

Carbon monoxide gas is toxic. Breathing it can cause unconsciousness and even kill you.

Avoid any enclosed areas or activities that expose you to carbon monoxide.

An enclosed area such as a garage can quickly fill up with carbon monoxide gas. Do not run the engine with the garage door closed. Even when the garage door is open, drive out of the garage immediately after starting the engine.

### Seat Belts

A seat belt is your best protection in all types of collisions. Airbags are designed to supplement seat belts, not replace them. So even though your vehicle is equipped with airbags, make sure you and your passengers always wear your seat belts and wear them properly.

#### ■ Lap/Shoulder Seat Belts

All five seating positions are equipped with lap/shoulder seat belts with emergency locking retractors. In normal driving, the retractor lets you move freely while keeping some tension on the belt. During a collision or sudden stop, the retractor locks to restrain your body. The rear seat belts also have a lockable retractor for use with child seats.

The front seats are equipped with automatic seat belt tensioners to enhance safety. The tensioners automatically tighten the front seat belts during a moderate to severe frontal collision, sometimes even if the collision is not severe enough to inflate the front airbags.

#### ■ Proper Use of Seat Belts

Follow these guidelines for proper use:

- All occupants should sit upright, well back in the seat, and remain in that position for the duration of the trip. Slouching and leaning reduces the effectiveness of the belt and can increase the chance of serious injury in a crash.
- Never place the shoulder part of a lap/shoulder seat belt under your arm or behind your back. This could cause very serious injuries in a crash.
- Two people should never use the same seat belt. If they do, they could be very seriously injured in a crash.
- Do not put any accessories on the seat belts. Devices intended to improve comfort or reposition the shoulder part of a seat belt can reduce the protective capability and increase the chance of serious injury in a crash.
- No one should sit in a seat with an inoperative seat belt or one that does not appear to be working correctly. Using a seat belt that is not working properly may not protect the occupant in a crash. Have a dealer check the belt as soon as possible.

#### **WARNING**

Not wearing a seat belt properly increases the chance of a serious injury or death in a crash, even though your vehicle has airbags.

Be sure you and your passengers always wear seat belts and wear them properly.

### ■ Seat Belt Inspection

Regularly check the condition of your seat belts as follows:

- Pull each belt out fully, and look for frays, cuts, burns, and wear.
- Check that the latches work smoothly and the belts retract easily. If a belt does not retract easily, cleaning the belt may correct the problem. Use only mild soap and warm water. Do not use bleach or cleaning solvents. Make sure the belt is completely dry before allowing it to retract.

Any belt that is not in good condition or working properly will not provide proper protection and should be replaced as soon as possible.

A belt that has been worn during a crash may not provide the same level of protection in a subsequent crash. Have your seat belts inspected by a dealer after any collision.

#### **⚠ WARNING**

Not checking or maintaining seat belts can result in serious injury or death if the seat belts do not work properly when needed.

Check your seat belts regularly and have any problem corrected as soon as possible.

### ■ Fastening a Seat Belt

Adjust your seat to the proper position (see page 36), and then follow the below steps.

1. Pull the seat belt out slowly.
2. Insert the latch plate into the buckle, then tug on the belt to make sure the buckle is secure. Make sure that the belt is not twisted or caught on anything.
3. Position the lap part of the belt as low as possible across your hips, then pull up on the shoulder part of the belt so the lap part fits snugly. This lets your strong pelvic bones take the force of a crash and reduces the chance of internal injuries.
4. If necessary, pull up on the belt again to remove any slack, then make sure that the belt rests across the center of your chest and over your shoulder. This spreads the forces of a crash over the strongest bones in your upper body.

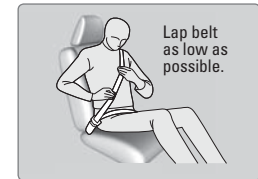
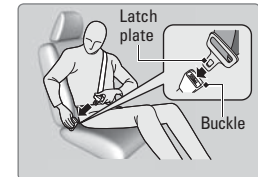

To release the belt, push the red PRESS button then guide the belt by hand until it has retracted completely.

#### **⚠ WARNING**

Improperly positioning the seat belts can cause serious injury or death in a crash.

Make sure all seat belts are properly positioned before driving.

### ■ Adjusting the Shoulder Anchor\*

The front seats have adjustable shoulder anchors to accommodate taller and shorter occupants.

1. Move the anchor up and down while holding the release button.
2. Position the anchor so that the belt rests across the center of your chest and over your shoulder.



*\*if equipped*

## Airbags

Your vehicle is equipped with three types of airbags: front airbags, side airbags, and side curtain airbags.

### ■ Front Airbags (SRS)

The front SRS airbags inflate in a moderate-to-severe frontal collision to help protect the head and chest of the driver and/or front passenger. They are housed in the center of the steering wheel for the driver, and in the dashboard for the front passenger. Both airbags are marked **SRS AIRBAG**.

SRS (Supplemental Restraint System) indicates that the airbags are designed to supplement seat belts, not replace them. Seat belts are the occupant's primary restraint system.

### ■ Advanced Airbags

Your front airbags have advanced features to help reduce the likelihood of airbag-related injuries to smaller occupants.

The driver's advanced front airbag system includes a seat position sensor. If the seat is too far forward, the airbag inflates with less force, regardless of the severity of the impact.

If there is a problem with the driver's seat position sensor, the SRS indicator will come on and the airbag will inflate with full (normal) force, regardless of the driver's seating position.

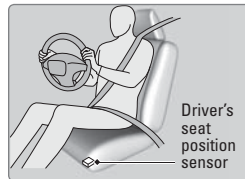

The passenger's advanced front airbag system has weight sensors. Although Honda recommends against carrying an infant or small child in front, if the sensors detect the weight of a child (up to 65 lbs or 29 kg), the system will automatically turn off the passenger's front airbag.

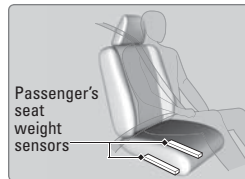

For both advanced front airbags to work properly:

- Do not spill any liquid on or under the seats.
- Do not put any object under the passenger's seat.
- Make sure any objects are positioned properly on the floor. Improperly positioned objects can interfere with the advanced airbag sensors.
- All occupants should sit upright and wear their seat belts properly.
- Do not place any cover over any part of the passenger side dashboard.

### ■ Side Airbags

The side airbags help protect the upper torso and pelvis of the driver or a front passenger during a moderate-to-severe side impact. They are housed in the outside edge of the driver's and front passenger's seat-backs. Both are marked **SIDE AIRBAG**.

### ■ Side Curtain Airbags

Side curtain airbags help protect the head and torso of the driver and passengers in outer seating positions during a moderate-to-severe side impact. The side curtain airbags equipped in this vehicle are also designed to help reduce the likelihood of partial and complete ejection of vehicle occupants through side windows in crashes, particularly rollover crashes.

The side curtain airbags are located in the ceiling above the side windows on both sides of the vehicle.

The side curtain airbags are designed to deploy in a rollover or moderate-to-severe side impact. If the SRS control unit senses that your vehicle is about to roll over, it immediately deploys both side curtain airbags and activates both front seat belt tensioners. If the impact is on the passenger's side, the passenger's side curtain airbag will inflate even if there are no occupants on that side of the vehicle.

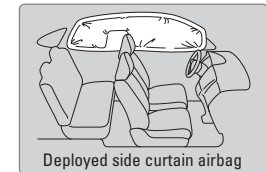
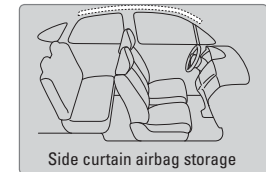

To get the best protection from the side curtain airbags, occupants should wear their seat belts properly and sit upright and well back in their seats.

Do not attach any objects to the side windows or roof pillars, as they can interfere with the proper operation of the side curtain airbags.

### When side curtain airbags deploy in a frontal collision

One or both side curtain airbags may inflate in a moderate-to-severe angled frontal collision. In this case, the side curtain airbags will deploy slightly after the front airbags.

### ■ Important Facts About Your Airbags

Always wear your seat belt properly, and sit upright and as far back from the steering wheel as possible while allowing full control of the vehicle. A front passenger should move their seat as far back from the dashboard as possible.

**Do not place hard or sharp objects between yourself and a front airbag.** Carrying hard or sharp objects on your lap, or driving with a pipe or other sharp object in your mouth, can result in injuries if your front airbag inflates.

**Do not attach or place objects on the front airbag covers.** Objects on the covers marked **SRS AIRBAG** could interfere with the proper operation of the airbags or be propelled inside the vehicle and hurt someone if the airbags inflate.

**Do not attach accessories on or near the side airbags.** They can interfere with the proper operation of the airbags, or hurt someone if an airbag inflates.

**Do not attach any objects to the side windows or roof pillars.** They can interfere with the proper operation of the side curtain airbags.

**Do not cover or replace the front seat-back covers.** This can prevent your side airbags from properly deploying during a side impact.

#### ⚠️ WARNING

An open glove box can cause serious injury to your passenger in a crash, even if the passenger is wearing the seat belt.

Always keep the glove box closed while driving.

### ■ Airbag System Indicators

If a problem occurs in the airbag system, the SRS indicator comes on and a message appears on the i-MID\*.

#### SRS (Supplemental Restraint System) Indicator

If the indicator comes on at any other time besides vehicle start-up, or does not come on at all, have the system checked by a dealer as soon as possible. If you don't, your airbags and seat belt tensioners may not work properly when they are needed.



#### ⚠️ WARNING

Ignoring the SRS indicator can result in serious injury or death if the airbag systems or tensioners do not work properly.

Have your vehicle checked by a dealer as soon as possible if the SRS indicator alerts you to a possible problem.

### Passenger Airbag Off Indicator

The indicator comes on to alert you that the front passenger's front airbag has been turned off. This occurs when the front passenger's weight sensors detect 65 lbs (29 kg) or less, the weight of an infant or small child, on the seat.

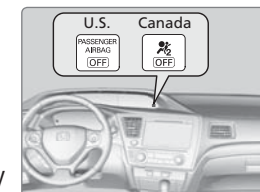

Infants and small children should always ride properly restrained in a back seat.

Objects placed on the seat can also cause the indicator to come on.

If the front passenger's seat is empty, the passenger's front airbag will not deploy and the indicator will not come on.

If the indicator comes on with no occupant or objects in the front passenger's seat, something may be interfering with the weight sensors, such as:

- An object hanging on the seat or in the seat-back pocket.
- A child seat or other object pressing against the rear of the seat-back.
- A rear passenger pushing or pulling on the back of the front passenger's seat.
- The front seat or seat-back is forced against an object on the seat or floor behind it.
- An object placed under the front passenger's seat.

If none of these conditions exist, have your vehicle checked by a dealer as soon as possible.

The passenger airbag off indicator may go on and off repeatedly if the total weight on the seat is near the airbag cutoff threshold.

\*if equipped

## ■ Airbag System Components

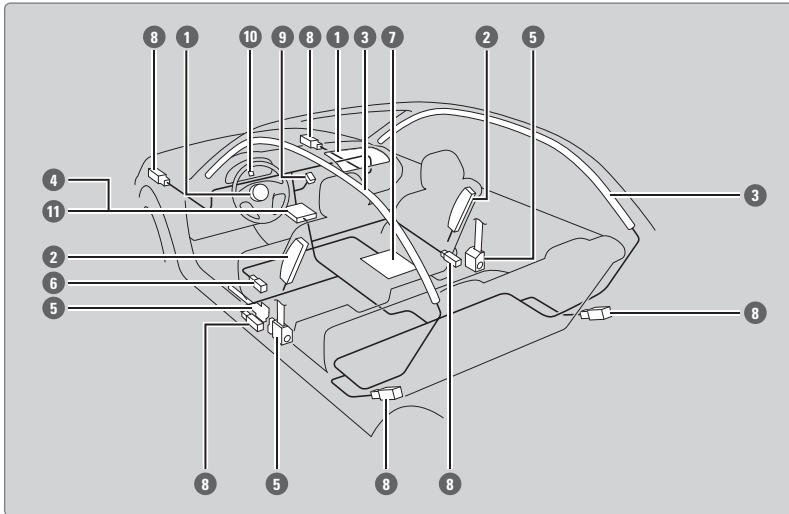

- 1 Two SRS (Supplemental Restraint System) front airbags. The driver's airbag is stored in the center of the steering wheel; the front passenger's airbag is stored in the dashboard. Both are marked **SRS AIRBAG**.
- 2 Two side airbags, one for the driver and one for the front passenger. The airbags are stored in the outer edges of the seat-backs. Both are marked **SIDE AIRBAG**.
- 3 Two side curtain airbags, one for each side of the vehicle. The airbags are stored in the ceiling, above the side windows. The front and rear pillars are marked **SIDE CURTAIN AIRBAG**.
- 4 An electronic control unit that continually monitors and can record information about the sensors, the airbag activators, the seat belt tensioners, and driver and front passenger seat belt use when the vehicle is on.
- 5 Automatic front seat belt tensioners. The driver's and front passenger's seat belts incorporate sensors that detect whether or not they are fastened.
- 6 A driver's seat position sensor. If the seat is too far forward, the airbag will inflate with less force.
- 7 Weight sensors in the front passenger's seat. The front passenger's airbag will be turned off if the weight on the seat is 65 lbs (29 kg) or less (the weight of an infant or small child).
- 8 Impact sensors that can detect a moderate-to-severe front or side impact.
- 9 An indicator on the dashboard that alerts you that the front passenger's front airbag has been turned off.
- 10 An indicator on the instrument panel that alerts you to a possible problem with the airbag system or seat belt tensioners.
- 11 A rollover sensor that detects whether the vehicle is about to roll over.

## ■ Airbag Care

You do not need to, and should not, perform any maintenance on or replace any airbag system components yourself. However, you should have your vehicle inspected by a dealer in the following situations:

### When the airbags have deployed

If an airbag has inflated, the control unit and other related parts must be replaced. Similarly, once an automatic seat belt tensioner has been activated, it must be replaced.

### When the vehicle has been in a moderate-to-severe collision

Even if the airbags did not inflate, have your dealer inspect the following: the driver's seat position sensor, weight sensors in the passenger's seat, front seat belt tensioners, and each seat belt that was worn during the crash.

### Do not remove or modify a front seat without first consulting a dealer

This would likely disable the driver's seat position sensor or the weight sensors in the passenger's seat. If it is necessary to remove or modify a front seat to accommodate a person with disabilities, contact a Honda dealer. For U.S. vehicles, call Honda Automobile Customer Service at (800) 999-1009. For Canadian vehicles, call Honda Canada Customer Relations at (888) 946-6329.



## Child Safety

Each year, many children are injured or killed in vehicle crashes because they are either unrestrained or not properly restrained. In fact, vehicle collisions are the number one cause of death of children ages 12 and under.

The National Highway Traffic Safety Administration and Transport Canada recommend that all children ages 12 and under be properly restrained in a rear seat. Some states or provinces/territories have laws restricting where children may ride.

To reduce the number of child deaths and injuries, every state, Canadian province and territory requires that infants and children be properly restrained when they ride in a vehicle.

### ■ Protecting Child Passengers

- An inflating front or side airbag can injure or kill a child sitting in the front seat.
- A child in the front seat is more likely to interfere with the driver's ability to safely control the vehicle.
- Statistics show that children of all sizes and ages are safer when they are properly restrained in a rear seat.
- Any child who is too small to wear a seat belt correctly must be restrained in an approved child seat that is properly secured to the vehicle using either the lap belt portion of the lap/shoulder belt or the lower anchors of the LATCH system.
- Never hold a child on your lap because it is impossible to protect them in the event of a collision.
- Never put a seat belt over yourself and a child. During a crash, the belt would likely press deep into the child and cause serious or fatal injuries.
- Never let two children use the same seat belt. Both children could be very seriously injured in a crash.
- Do not allow children to operate the doors, windows, or seat adjusters.
- Do not leave children in the vehicle unattended, especially in hot weather when the inside of the vehicle can get hot enough to kill them. They could also activate vehicle controls, causing it to move unexpectedly.

### ⚠️ WARNING

Children who are unrestrained or improperly restrained can be seriously injured or killed in a crash.

Any child too small for a seat belt should be properly restrained in a child seat. A larger child should be properly restrained with a seat belt, using a booster seat if necessary.

### ⚠️ WARNING

Allowing a child to play with a seat belt or wrap one around their neck can result in serious injury or death.

Instruct children not to play with any seat belt and make sure any unused seat belt a child can reach is buckled, fully retracted, and locked.

### ■ Protecting Infants

An infant must be properly restrained in a rear-facing, reclining child seat until the infant reaches the seat maker's weight or height limit for the seat, and the infant is at least one year old. Many experts recommend use of a rear-facing seat for a child up to two years old if the child's height and weight are appropriate for a rear-facing seat.

Child seats must be placed and secured in a rear seating position. Rear-facing child seats should never be installed in a forward-facing position.



When properly installed, a rear-facing child seat may prevent the driver or a front passenger from moving their seat all the way back, or from locking their seat-back in the desired position. If this occurs, we recommend that you install the child seat directly behind the front passenger's seat, move the seat as far forward as needed, and leave it unoccupied. Or, you may wish to get a smaller rear-facing child seat.

### ⚠️ WARNING

Placing a rear-facing child seat in the front seat can result in serious injury or death during a crash.

Always place a rear-facing child seat in the rear seat, not the front.

### ■ Protecting Smaller Children

If a child is at least one year old and within the weight range indicated by the child seat manufacturer, the child should be properly restrained in a firmly secured forward-facing child seat.

We strongly recommend placing a forward-facing child seat in a rear seating position.

Placing a forward-facing child seat in the front seat can be hazardous, even with advanced front airbags that automatically turn the passenger's front airbag off. A rear seat is the safest place for a child.

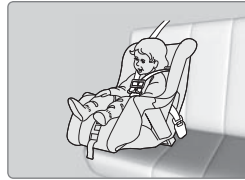

#### **⚠️ WARNING**

Placing a forward-facing child seat in the front seat can result in serious injury or death if the front airbag inflates.

If you must place a forward-facing child seat in front, move the vehicle seat as far back as possible, and properly restrain the child.

### ■ Selecting a Child Seat

Most child seats are LATCH-compatible (Lower Anchors and Tethers for CHildren). Some have a rigid-type connector, while others have a flexible-type connector. Both are equally easy to use. Some existing and previously owned child seats can only be installed using the seat belt. Whichever type you choose, follow the child seat manufacturer's use and care instructions as well as the instructions in this manual. Proper installation is key to maximizing your child's safety.

In seating positions and vehicles not equipped with LATCH, a LATCH-compatible child seat can be installed using the seat belt and a top tether for added security. This is because all child seats are required to be designed so that they can be secured with a lap belt or the lap part of a lap/shoulder belt. In addition, the child seat manufacturer may advise that a seat belt be used to attach a LATCH-compatible seat once a child reaches a specified weight. Please read the child seat owner's manual for proper installation instructions.

#### Important considerations when selecting a child seat

Make sure the child seat meets the following three requirements:

- The child seat is the correct type and size for the child.
- The child seat is the correct type for the seating position.
- The child seat is compliant with Federal Motor Vehicle Safety Standard 213 or Canadian Motor Vehicle Safety Standard 213.

### ■ Installing a LATCH-Compatible Child Seat

A LATCH-compatible child seat can be installed in either of the two outer rear seats. A child seat is attached to the lower anchors with either the rigid or flexible type of connectors.

1. Locate the lower anchors under the marks.
2. Place the child seat on the vehicle seat, then attach the child seat to the lower anchors according to the instructions that came with the child seat. Make sure that the lower anchors are not obstructed by the seat belt or any other object.
3. Open the tether anchor cover behind the head restraint. Raise the head restraint to its highest position, then route the tether strap between the head restraint legs, and secure the tether strap hook onto the anchor.
4. Tighten the tether strap according to the seat maker's instructions.
5. Make sure the child seat is firmly secured by rocking it forward and back and side to side; little movement should be felt.
6. Make sure any unused seat belt that a child can reach is buckled, the lockable retractor is activated, and the belt is fully retracted and locked.

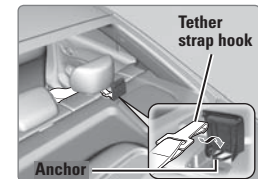
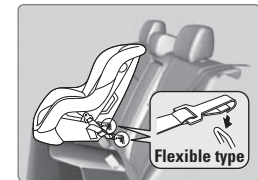
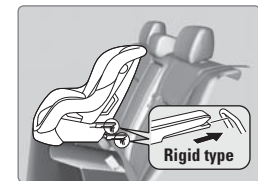

### ■ Installing a Child Seat with a Lap/Shoulder Seat Belt

1. Place the child seat on the vehicle seat.
2. Route the seat belt through the child seat according to the seat maker's instructions, and insert the latch plate into the buckle. Insert the latch plate fully until it clicks.
3. Slowly pull the shoulder part of the belt all the way out until it stops. This activates the lockable retractor.
4. Let the seat belt completely wind up into the retractor, then try to pull it out to make sure the retractor is locked. If you are able to pull the shoulder belt out, the lockable retractor is not activated. Pull the seat belt all the way out, and repeat steps 3 – 4.
5. Grab the shoulder part of the seat belt near the buckle, and pull up to remove any slack from the lap part of the belt. When doing this, place your weight on the child seat and push it into the vehicle seat.
6. Make sure the child seat is firmly secured by rocking it forward and back and side to side; little movement should be felt.
7. Make sure any unused seat belt that a child can reach is buckled, the lockable retractor is activated, and the belt is fully retracted and locked.

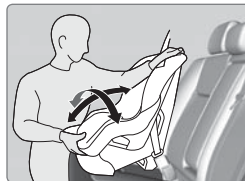
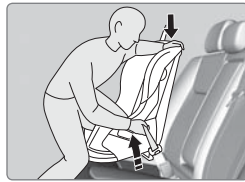
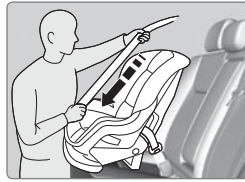

To deactivate a lockable retractor, release the buckle and allow the seat belt to wind up all the way.

### ■ Adding Security with a Tether

A tether anchorage point is provided behind each rear seating position. Regardless of whether it is installed with LATCH or a seat belt, a child seat that comes with a tether should use the tether for additional security.

1. Locate the appropriate tether anchorage point and lift the cover.
2. Raise the head restraint to its highest position, then route the tether strap through the head restraint legs. Make sure the strap is not twisted.
3. Secure the tether strap hook onto the anchor.
4. Tighten the tether strap according to the seat maker's instructions.

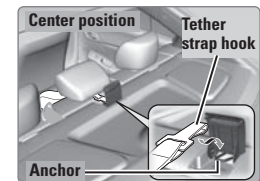
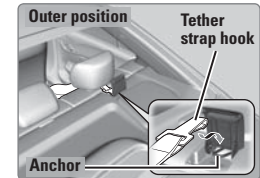
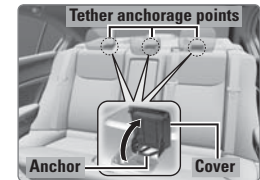

**Protecting Larger Children**

When a child is too big for a child seat, secure the child in a rear seat using the lap/shoulder seat belt.

Have the child sit upright and all the way back, then ensure the following:

- The child's knees bend comfortably over the edge of the seat.
- The shoulder belt crosses between the child's neck and arm.
- The lap part of the seat belt is as low as possible, touching the child's thighs.
- The child can stay seated for the whole trip.



If a lap/shoulder belt cannot be used properly, position the child in a booster seat in a rear seating position. For the child's safety, check that the child meets the booster seat manufacturer's recommendations.

Some U.S. states and Canadian provinces/territories require children to use a booster seat until they reach a given age or weight (e.g., 6 years or 60 lbs). Be sure to check current laws in the state or province/territory where you intend to drive.

**WARNING**

Allowing a child age 12 or under to sit in the front can result in injury or death if the passenger's front airbag inflates.

If a larger child must ride in front, move the vehicle seat as far to the rear as possible, then have the child sit up properly and wear the seat belt properly, using a booster seat if needed.

**Safety Label Locations**

Safety labels are in the locations shown. They warn you of potential hazards that can cause serious injury or death. Read these labels carefully.

**Sedan, Coupe, and Si models**

**Sun visor**  
U.S. models: **WARNING** EVEN WITH ADVANCED AIR BAGS...  
Canadian models: **CAUTION** TO AVOID SERIOUS INJURY... **PRECAUTIONS** PROTECT YOUR EYES BY WEARING PROPERLY FITTING SUNGLASSES...

**Dashboard (U.S. models only)**  
This Vehicle is Equipped with Advanced Air Bags. **WARNING** EVEN WITH ADVANCED AIR BAGS...

**Radiator cap**  
**DANGER** WARNING: HOT FLUIDS OR PRESSURE CAN BE RELEASED FROM THE RADIATOR CAP...

**Doorjambs**  
U.S. models: **SIDE AIRBAG**...  
Canadian models: **SIDE AIRBAG**... **CAUTION** SEATBELT USE...

**Natural Gas (CNG) models**

**Hood**  
**WARNING** This vehicle is equipped with compressed natural gas (CNG) pressure... **First inspection** CNG tank expiration date

**CNG tank**  
**NO FUELING TANKS** THIS CONTAINER SHOULD BE FULLY INSPECTED... **CNG ONLY - DO NOT USE AFTER 01/2027**... **DANGER** THIS IS A HIGHLY FLAMMABLE AND HIGHLY EXPLOSIVE GAS... **CNG tank production date**

**Fuel lid**  
**WARNING** Do not use fuel filler if outside temperature is below 44°F (5°C)... **CNG FUELED VEHICLE** SERVICE PRESSURE 24.800 kPa(350PSI) CNG TANK EXPIRATION DATE... **First inspection** CNG tank expiration date

**Trunk lid**  
CNG label

## Reporting Safety Defects

### In the U.S.

If you believe that your vehicle has a defect which could cause a crash or could cause injury or death, you should immediately inform the National Highway Traffic Safety Administration (NHTSA) in addition to notifying American Honda Motor Co., Inc.

If NHTSA receives similar complaints, it may open an investigation, and if it finds that a safety defect exists in a group of vehicles, it may order a recall and remedy campaign. However, NHTSA cannot become involved in individual problems between you, your dealer, or American Honda Motor Co., Inc.

To contact NHTSA, you may call the Vehicle Safety Hotline toll-free at 1-888-327-4236 (TTY: 1-800-424-9153); go to <http://www.safercar.gov>, or write to: Administrator, NHTSA, 1200 New Jersey Avenue, SE., Washington, DC 20590. You can also obtain other information about motor vehicle safety from <http://www.safercar.gov>.

### In Canada

If you believe that your vehicle has a defect which could cause a crash or could cause injury or death, you should immediately inform Honda Canada, Inc., and you may also inform Transport Canada.

If Transport Canada receives similar complaints, it may open an investigation, and if it finds that a safety defect exists in a group of vehicles, it may lead to a recall and remedy campaign. However, Transport Canada cannot become involved in individual problems between you, your dealer, or Honda Canada, Inc.

To contact Transport Canada's Defect Investigations and Recalls Division, you may call 1-800-333-0510. For more information on reporting safety defects or about motor vehicle safety, go to <http://www.tc.gc.ca/roadsafety>.

## INSTRUMENT PANEL

Learn about the indicators, gauges, and displays related to driving the vehicle.

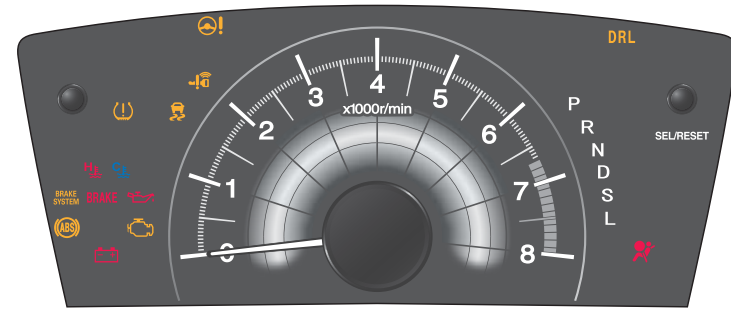

Indicators briefly appear with each engine start and then go out. Red and amber indicators are most critical. Blue and green indicators are used for general information.

### Malfunction Indicators

These are the most critical indicators. If they come on and stay lit while driving or at any other time, there may be a problem. See your dealer if necessary.

#### **BRAKE** Brake system

U.S.

- Brake fluid is low.



Canada

- The brake system has a problem.

Press the brake pedal lightly to check pedal pressure. If normal, check the brake fluid level when you stop. If abnormal, take immediate action. If necessary, downshift the transmission to slow the vehicle using engine braking. Have your vehicle repaired immediately.



#### **Low oil pressure**

Engine oil pressure is low. Stop in a safe place. Open the hood. Check the oil level, and add oil if necessary (see page 121). If the indicator does not turn off, have your vehicle repaired immediately.



#### **Charging system**

The battery is not charging. Turn off all electrical items, but do not turn off the vehicle to prevent further battery discharge. Have your vehicle repaired immediately.



#### **Supplemental Restraint System (SRS)**



There is a problem with one of the airbag systems or seat belt tensioners.





#### **Smart Entry system\***

There is a problem with the smart entry system.

\*if equipped

- 
**Malfunction indicator lamp** (check engine light)
  - The emissions control system may have a problem, or the fuel cap is loose or missing.
  - (Blinks) A misfire in the engine's cylinders is detected. Stop in a safe place, and wait for the engine to cool down.
  
- 
**Anti-lock Brake System (ABS)**

There is a problem with the anti-lock brake system. Your vehicle still has normal braking ability, but no anti-lock function.
  
- 
**Tire Pressure Monitoring System (TPMS)\***

There is a problem with the tire pressure monitoring system, or the vehicle is fitted with the compact spare tire.
  
- 
**High temperature**

Blinks when the engine coolant temperature goes up, and stays on if the temperature continues to rise. Drive slowly or pull over to prevent overheating.
  
- 
**Low temperature**

The engine coolant temperature is low. If the indicator stays on, there may be a problem with the temperature sensors.
  
- 
**Daytime Running Lights (DRL)\***

There is a problem with the DRL system.
  
- 
**Vehicle Stability Assist (VSA®) system**

There is a problem with the VSA system.
  
- 
**Brake system**

There is a problem with the brake system.
  
- 
**Electric Power Steering (EPS)**

There is a problem with the EPS system.

\*if equipped





### Condition Indicators

These indicators may require you to perform an action.

- 
**Parking brake**

Release the parking brake before driving. You will hear a beep if you drive with it not fully released.
  
- 

Canada
  
- 
**Seat belt reminder**

Make sure seat belts are fastened for you and all passengers. The indicator blinks and beeps sound continuously if you or your front passenger has not fastened your seat belts when you begin driving. If the indicator remains on after seat belts are fastened, see your dealer.
  
- 
**Door open**

A door is not closed. A beep sounds while driving.
  
- 
**Trunk open**

The trunk is not closed.
  
- 
**Low fuel**

Refuel as soon as possible. If the indicator blinks, there is a problem with the fuel gauge. See your dealer.
  
- 
**Low tire pressure\***

Stop in a safe place, check tire pressures, and inflate tire(s) if necessary. The indicator also appears if your vehicle is fitted with the compact spare tire. Have your regular tire repaired or replaced as soon as possible.

\*if equipped





**Washer fluid level (Canadian models)\***

The washer fluid is low. Refill the washer fluid (see page 125).



**System message\***

When a condition or malfunction indicator comes on, a message also appears on the multi-information display. Check the display for more information.



**Vehicle Stability Assist (VSA®) system**

(Blinks) VSA is active.



**Maintenance Minder™\***

Scheduled maintenance for your vehicle is due.



**Immobilizer**

Your key or remote transmitter cannot be recognized by the vehicle. If the indicator blinks, you may not be able to start the engine. Turn the vehicle off, and then on again. If it continues to blink, there may be a problem with the system. See your dealer.

**On/Off Indicators**

These indicators remind you when an item is on or off.



VSA off



Fog lights\* on



CRUISE MAIN on



High beams on



CRUISE CONTROL on



Exterior lights on



Turn signals/hazards on



ECON mode\* on

**Gauges**

These gauges include speed and fuel information.

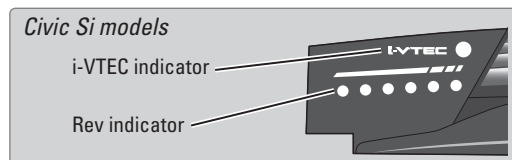
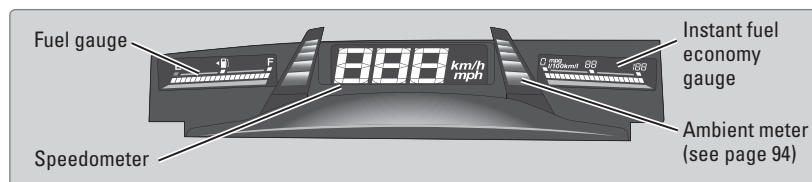

\*if equipped

**Information Display\***

Consists of several displays that provide you with useful information.

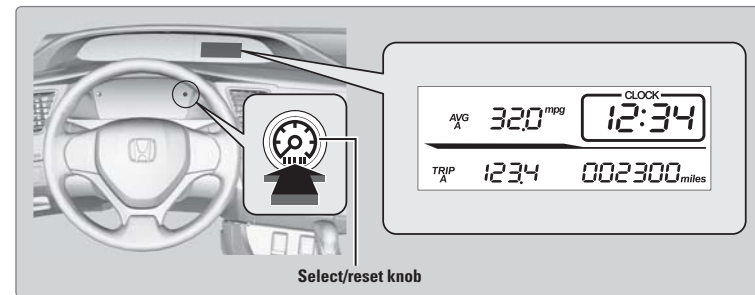

Press the select/reset knob to cycle through the displays shown below.

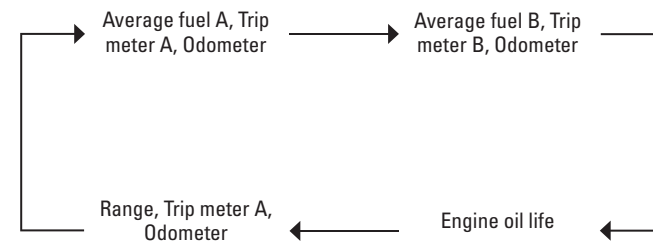

\*if equipped

### Intelligent Multi-Information Display (i-MID)\*

Consists of several displays that provide you with useful information.

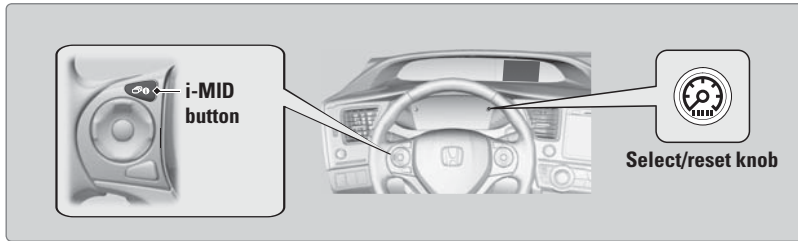

#### Main Displays

Press the display button to cycle through the displays shown below.

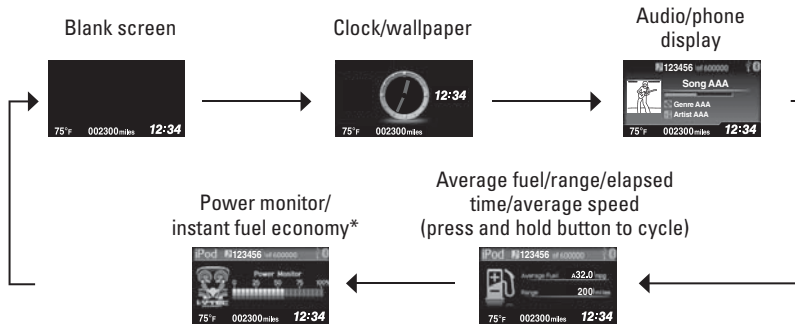

#### Trip Computer

Press the select/reset knob to cycle through the displays shown below.

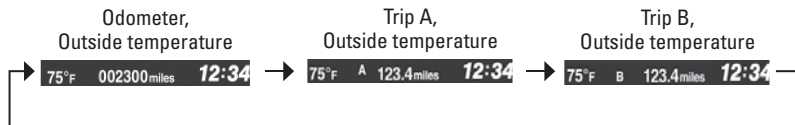

\*if equipped

## VEHICLE CONTROLS

Learn about the various controls necessary for operating and driving the vehicle.

### Using the Remote Transmitter\*

Lock or unlock the doors and trunk.

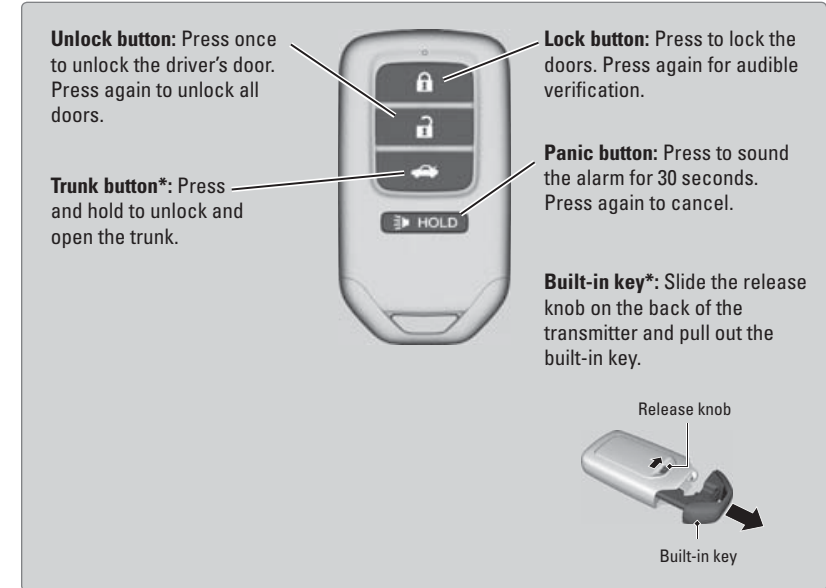

#### NOTICE

Leaving the key or remote transmitter in the vehicle can result in theft or accidental movement of the vehicle. Always take it with you whenever you leave the vehicle unattended.

\*if equipped

### Smart Entry System\*

When you carry the remote transmitter (for example, in a pocket or purse) and it is outside the vehicle and within range (about 32 inches or 80 cm), you can lock or unlock the doors and trunk without handling the transmitter.

#### ■ Unlocking/Locking the Doors

**To unlock:** Grab the driver's door handle when the vehicle is off to unlock the driver's door. Grab the front passenger's door handle to unlock all doors.

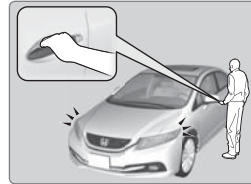

**To lock:** Press the door lock button on the front door handle when the vehicle is off. If the remote transmitter is inside the vehicle, the doors will not lock.



#### ■ Unlocking the Trunk

Press the trunk release button to unlock and open the trunk.

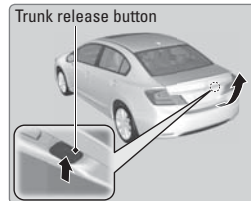

*\*if equipped*

### Door Operation

Use several methods to lock or unlock the doors.

#### ■ Using the Lock Tab

**To unlock:** When you unlock the door using the lock tab on the driver's door, only the driver's door unlocks.

**To lock:** When you lock the door using the lock tab on the driver's door, all the other doors lock at the same time.

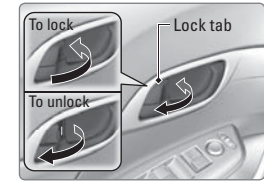

#### ■ Using the Front Door Inner Handle

When you pull either front door inner handle, the door unlocks and opens. On vehicles with smart entry, pulling the driver's door inner handle unlocks all other doors.

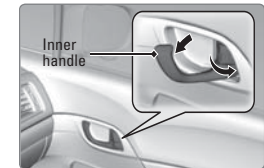

#### ■ Using the Master Door Lock Switch

**To unlock:** Press the unlock side of the switch to unlock all doors.

**To lock:** Press the lock side of the switch to lock all doors.

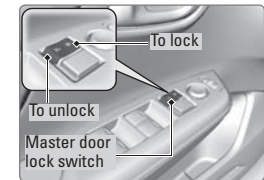

#### ■ Childproof Door Locks\*

The childproof door locks prevent the rear doors from being opened from the inside regardless of the position of the lock tab.

Slide the lever in the rear door to the lock position, and close the door.

Open the door using the outer door handle.

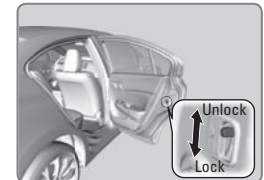

#### ■ Using the Trunk Opener

Pull the trunk release near the bottom of the driver's seat to unlock and open the trunk.



*\*if equipped*

### Power Window Operation

The power windows can be opened and closed when the vehicle is on by using the switches on the doors. The switches on the driver's side can be used to open and close all the windows.

#### Automatic Operation\*

**To open:** Push the switch down firmly.

**To close:** Pull the switch up firmly.

The window opens or closes completely. To stop the window at any time, push or pull the switch again briefly.

#### Manual Operation

**To open:** Push the switch down lightly.

**To close:** Pull the switch up lightly.

Release the switch when the windows reach the desired position.

#### Power Window Lock

Push in the power window lock button so only the driver's window can be operated. The driver can operate all other windows using the specific switches.

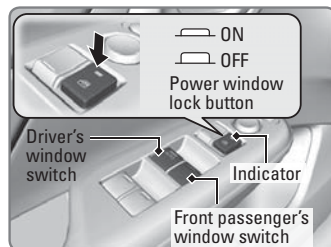

#### ⚠️ WARNING

Closing a power window on someone's hands or fingers can cause serious injury.

Make sure your passengers are away from the windows before closing them.

*\*if equipped*

### Power Moonroof Operation\*

The moonroof can be opened and closed when the vehicle is on by using the switch on the ceiling.

#### Automatic Operation

**To open:** Push the switch back firmly to the second detent, then release.

**To close:** Push the switch forward firmly to the second detent, then release.

The moonroof opens or closes completely. To stop the moonroof at any time, push the switch briefly.

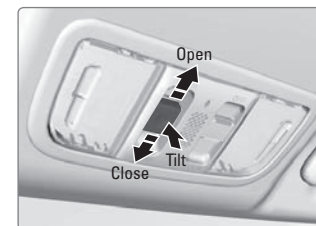

#### Manual Operation

**To open:** Push and hold the switch back to the first detent until the desired position is reached.

**To close:** Push and hold the switch forward to the first detent until the desired position is reached.

#### Moonroof Tilt

**To tilt:** Push the center of the switch.

**To close:** Push the switch forward firmly, then release.

#### NOTICE

Opening the moonroof in below freezing temperatures or when it is covered with snow or ice can damage the moonroof panel or motor.

#### ⚠️ WARNING

Closing the moonroof on someone's hands or fingers can cause serious injury.

Make sure your passengers are away from the moonroof before closing it.

*\*if equipped*

### Interior and Exterior Lights

Operate interior and exterior lights when the vehicle is on or off.

#### Brightness Control

Adjust instrument panel brightness when the vehicle is on.

**To brighten:** Turn the knob to the right.

**To dim:** Turn the knob to the left.

A beep sounds when the brightness reaches minimum or maximum.



#### Interior Lights

Change the interior light settings using the switch on the ceiling.

**ON position:** Interior lights remain on.

**Door-activated position:** Interior lights come on when any of the doors are opened, the driver's door is unlocked, or the vehicle is turned off.

**OFF position:** Interior lights remain off.

**Map lights\*:** Press the front map lights to turn on or off.

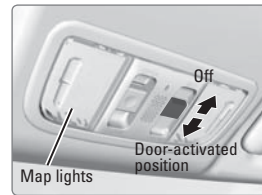

#### Exterior Lights

Rotate the switches on the headlight lever to operate the exterior lights.

**OFF:** All exterior lights are off.

☞☞: Turn on exterior lights except headlights.

**AUTO:** Turn on the automatic lighting feature\*. Headlights turn on or off depending on ambient brightness when the vehicle is on. Headlights automatically come on after the wipers are engaged for a certain time.

☞☞☞: Turn on all exterior lights including headlights.

☞☞☞: Turn fog lights\* on or off.

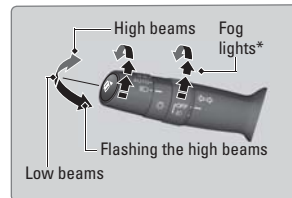

*\*if equipped*

### One-Touch Turn Signal

Use this quick and convenient method to signal a lane change.

Lightly push the turn signal lever up or down for a three-blink sequence.

For a continuous signal, push the lever up or down until it locks into place.

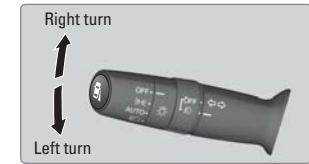

### Wiper Operation

The windshield wipers and washers can be used when the vehicle is on. Move the wiper lever up or down to the desired position.

#### Headlight-Wiper Integration\*

When the headlights are in the AUTO position, they automatically turn on when the front wipers operate several times within a certain interval. The headlights turn off shortly after the wipers are turned off, or if there is enough ambient light.

#### Intermittent Wipers

When you move the lever to the INT position, the wipers operate based on the wiper delay. Adjust the wiper delay using the adjustment ring\*.

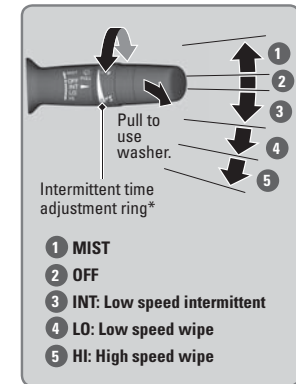

#### NOTICE

Do not use the wipers when the windshield is dry. The windshield will get scratched, or the rubber blades will get damaged.

In cold weather, the blades may freeze to the windshield, becoming stuck. Operating the wipers in this condition may damage the wipers. Use the defroster to warm the windshield, or manually clear the windshield of ice and snow before turning on the wipers.

*\*if equipped*

## Adjusting the Seats

Make seat adjustments before driving to ensure the best comfort and safety.

### Adjusting the Front Seats

Adjust the driver's seat as far back as possible while allowing you to maintain full control of the vehicle. You should be able to sit upright and well back in the seat, adequately press the pedals without leaning forward, and grip the steering wheel comfortably. The passenger's seat should be adjusted so that it is as far back from the front airbag in the dashboard as possible.

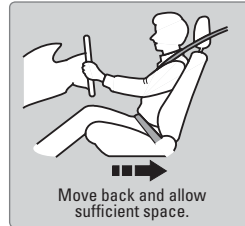

The National Highway Traffic Safety Administration and Transport Canada recommend that drivers allow at least 10 inches (25 cm) between the center of the steering wheel and the chest.

### Power Driver's Seat\*

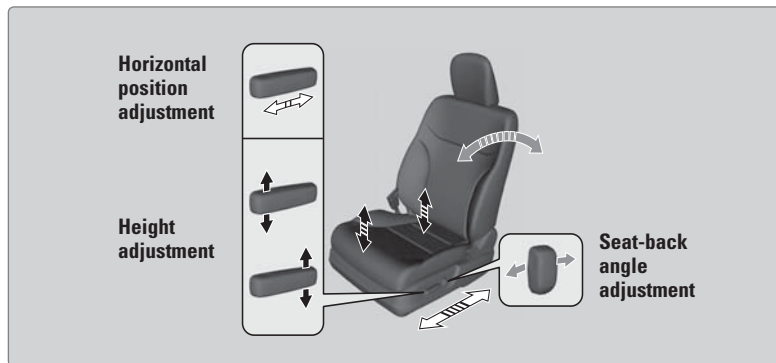

#### ⚠️ WARNING

Reclining the seat-back too far can result in serious injury or death in a crash. Adjust the seat-back to an upright position, and sit well back in the seat.

#### ⚠️ WARNING

Sitting too close to a front airbag can result in serious injury or death if the front airbags inflate. Always sit as far back from the front airbags as possible while maintaining control of the vehicle.

*\*if equipped*

### Manual Seats\*

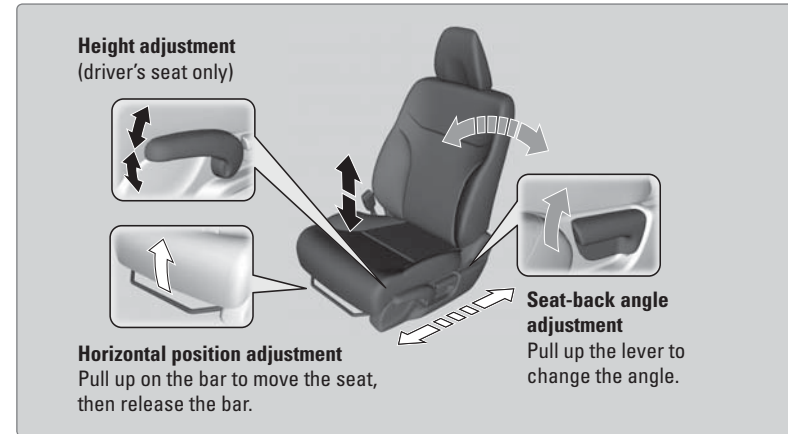

#### ⚠️ WARNING

Sitting improperly or out of position can result in serious injury or death in a crash.

Always sit upright, well back in the seat, with your feet on the floor.

### Floor Mats\*

Position the front seat floor mats properly, and anchor them. If they are not properly positioned, the floor mats can interfere with the front seat functions.

**Do not put additional floor mats on top of the anchored mats.**

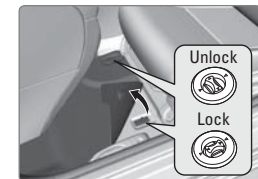

*\*if equipped*



**■ Adjusting the Head Restraints**

Your vehicle is equipped with head restraints in all seating positions. Head restraints are most effective for protection against whiplash and other rear-impact crash injuries.

The center of the back of the occupant's head should rest against the center of the restraint. The tops of the occupant's ears should be level with the center height of the restraint.

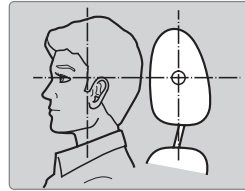

**To raise the head restraint:** Pull it upward.

**To lower the head restraint:** Push it down while pressing the release button.

**To remove the head restraint:** Pull the restraint up as far as it will go. Then push the release button, and pull the restraint up and out.

**To reinstall a head restraint:** Insert the legs back in place, then adjust the head restraint to an appropriate height while pressing the release button. Pull up on the restraint to make sure it is locked in position.

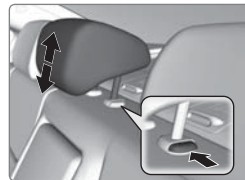
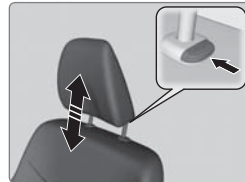

In order for the head restraint system to work properly:

- Do not hang any items on the head restraints, or from the restraint legs.
- Do not place any object between an occupant and the seat-back.
- Install each restraint in its proper location.

**⚠ WARNING**

Improperly positioning head restraints reduces their effectiveness and increases the likelihood of serious injury in a crash. Make sure head restraints are in place and positioned properly before driving.

**⚠ WARNING**

Failure to reinstall, or correctly reinstall, the head restraints can result in severe injury during a crash. Always replace the head restraints before driving.

**■ Folding Down the Rear Seats**

The rear seat-back(s\*) can be folded down to make room for large items in the trunk.

1. Remove the center shoulder belt from the guide.

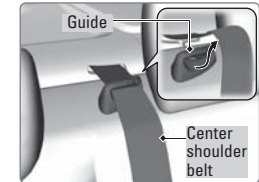

2. Pull the release lever in the trunk to release the lock.

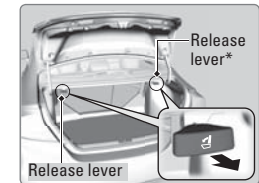

3. Fold down the seat-back. Remove the rear head restraints if necessary (see page 38).

Push the seat-back up firmly until it locks into place to return it to its original position.



Make sure all items in the trunk or items extending through the opening into the rear seats are properly secured. Loose items can fly forward if you have to brake hard.

\*if equipped

### Adjusting the Steering Wheel

The steering wheel height and distance from your body can be adjusted so that you can comfortably grip the steering wheel in an appropriate driving posture.

1. Pull up the steering wheel adjustment lever.
2. Move the steering wheel up or down, and in or out.
3. Push down the steering wheel adjustment lever to lock the steering wheel in position.

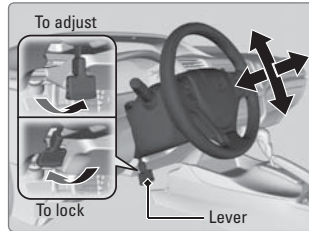

### ⚠ WARNING

Adjusting the steering wheel position while driving may cause you to lose control of the vehicle and be seriously injured in a crash. Adjust the steering wheel only when the vehicle is stopped.

### Adjusting the Mirrors

Adjust the angle of the mirrors for the best visibility when you are sitting in the correct driving position.

#### ■ Rearview Mirror with Day/Night Positions

Manually adjust the position to reduce headlight glare from vehicles behind you. Flip the tab to switch between day and night positions.

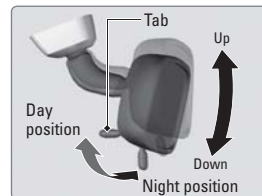

#### ■ Power Door Mirrors

Adjust the power door mirrors when the vehicle is on.

**L/R selector switch:** Select the left or right mirror. After adjusting the mirror, return the switch to the center position.

**Mirror position adjustment switch:** Press the switch left, right, up, or down to move the mirror.

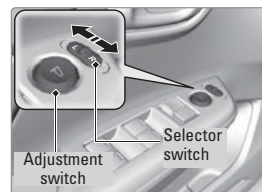

### Air Conditioning System\*

Manually control the front and rear heating and cooling in your vehicle's interior using the buttons on the dashboard.

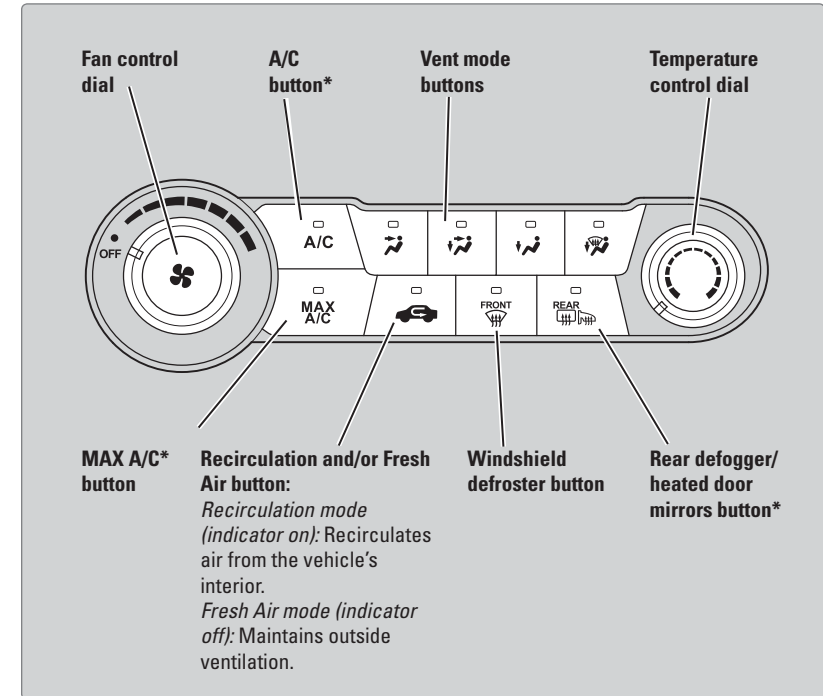

\*if equipped

### Climate Control System\*

The automatic climate control system can maintain your preferred interior temperature by selecting the proper mix of heated or cooled air and fan speed. Use the buttons on the dashboard to control the system.

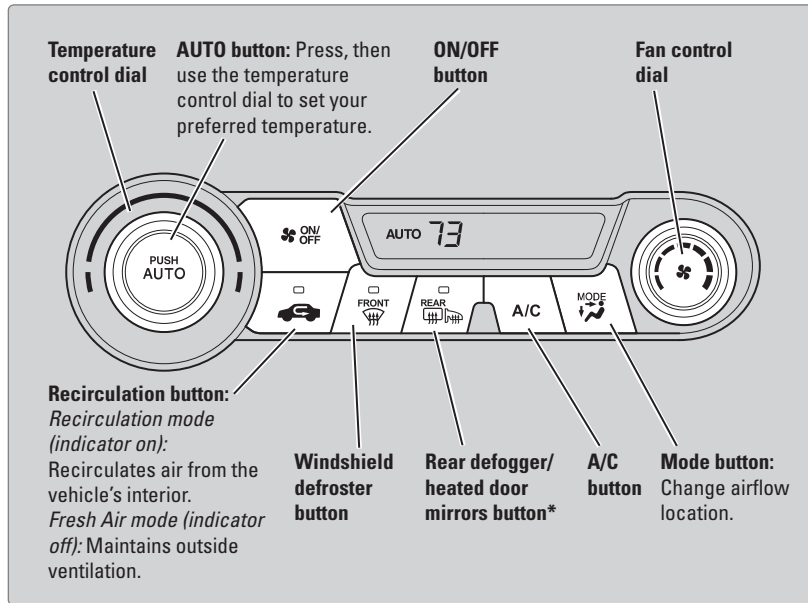

### Seat Heaters\*

Quickly warm the front seats when the vehicle is on. Press the seat heater switch in the front console to the LO or HI position. An indicator appears for the selected setting. Return the switch to the middle position to turn off.



### ⚠ WARNING

Heat-induced burns are possible when using seat heaters.

Persons with a diminished ability to sense temperature (e.g., persons with diabetes, lower-limb nerve damage, or paralysis) or with sensitive skin should not use the seat heaters.

\*if equipped

### Customized Features\*

Use the Vehicle Menu in the i-MID to customize certain features, such as the display, the trip computer, and door locking/unlocking. Use the steering wheel controls to make and enter selections when the vehicle is stopped.

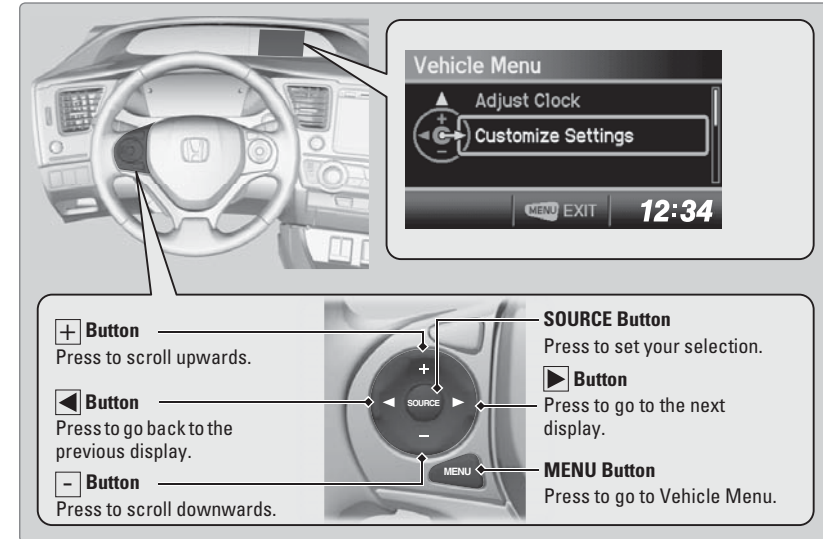

### ■ Changing Settings Using the Touchscreen\*

Select items on the touchscreen to make and enter selections.

1. Select SETTINGS.
2. Select an option (Clock/Info, Audio, Bluetooth, Phone, Camera, System, or Navi\*).
3. Select a setting option, and make your preferred changes.
4. Press BACK to exit the menus.

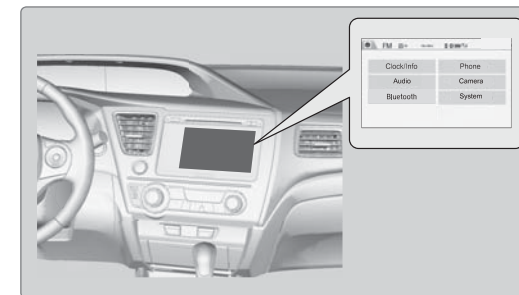

\*if equipped

## Setting the Clock

Adjust the time using the steps described for your vehicle type.

### ■ Using the CLOCK Knob

Use this method for vehicles with one display.

1. Press the CLOCK knob to enter the clock screen.
2. Turn the knob to adjust the hour value. Press the knob to set.
3. Turn the knob to adjust the minute value. Press the knob to set.

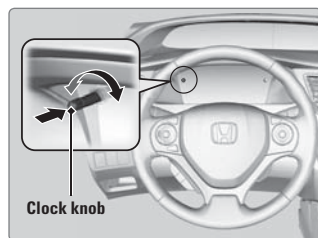

### ■ Using the Settings Menu

Use this method for vehicles with display audio. Touch items to make selections.

1. Select Settings.
2. Select Clock/Info.
3. Select Clock Adjustment.
4. Adjust the hour and minute values.
5. Select OK when complete.

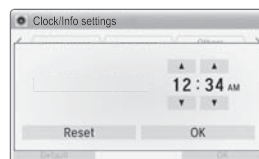

On vehicles with navigation, the time is automatically set using GPS signals.

## AUDIO AND CONNECTIVITY

Learn how to operate the vehicle's audio system.

### Basic Audio Operation

Connect audio devices and operate buttons and displays for the audio system.

#### ■ USB/HDMI Port\*

1. Open the port cover in the front console.
2. Connect a USB flash drive or iPod/iPhone® cable connector to the USB port, or an HDMI cable to the HDMI port.

An additional USB cable is located in the center console.

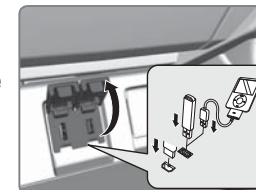

*iPod and iPhone are trademarks of Apple, Inc. Additional cables and accessories sold separately.*

#### ■ Auxiliary Input Jack\*

Connect standard audio devices with a 1/8-inch (3.5 mm) stereo miniplug.

1. Open the AUX cover in the front console.
2. Insert the miniplug attached to the audio device into the jack. The audio system switches to AUX mode. Use the device to control the audio.

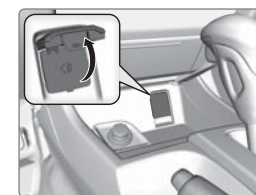

*State or local laws may prohibit the operation of handheld electronic devices while operating a vehicle.*

#### ■ Accessory Power Socket

Open the socket cover in the front console to use power when the vehicle is on.



### NOTICE

Do not insert an automotive type cigarette lighter element. This can overheat the power socket.

■ **Steering Wheel Controls\***

You can operate certain functions of the audio system using the steering wheel controls.

**SOURCE button:** Cycle through available audio modes.

**◀/▶ buttons:** Change presets, tracks, albums, or folders.

**+/- buttons:** Adjust audio volume.

**MENU button:** On vehicles with display audio, press and hold to view options for the current audio source. Use the other buttons to navigate through the options.



**FM/AM/SiriusXM® Radio**

Press ▶ or ◀ for the next or previous station.

Press and hold ▶ or ◀ for the next or previous strong station.

**CD/iPod®/USB/Bluetooth® Audio**

Press ▶ or ◀ for the next or previous track.

Press and hold ▶ or ◀ for the next or previous folder (CD/USB).

**Pandora®**

Press ▶ for the next song.

Press and hold ▶ or ◀ for the next or previous station.

*\*if equipped*

■ **Adjusting the Sound**

Adjust various sound settings.

**Vehicles with information display**

Press the TUNE/SOUND knob to scroll through sound modes. Rotate the knob to adjust the setting for each mode.

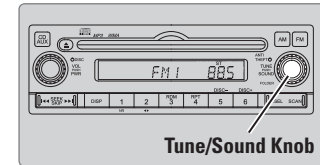

**Vehicles with one display**

Use the selector knob to make and enter selections.

1. Press the SETUP button.
2. Select Sound Settings.
3. Select a sound mode to change, and adjust it using the selector knob.
4. Press the Back button to exit the menu.

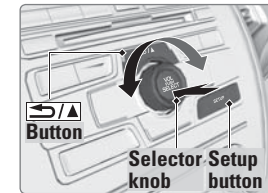

**Vehicles with display audio**

Make and enter selections using the touchscreen.

1. Select Settings.
2. Select Audio.
3. Select Sound.
4. Select the tabs to change the sound mode and adjust the setting.
5. Select OK when complete.

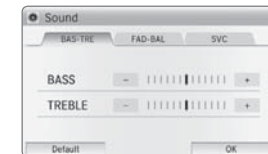

### FM/AM Radio

Play FM or AM radio stations.

#### Models with information display

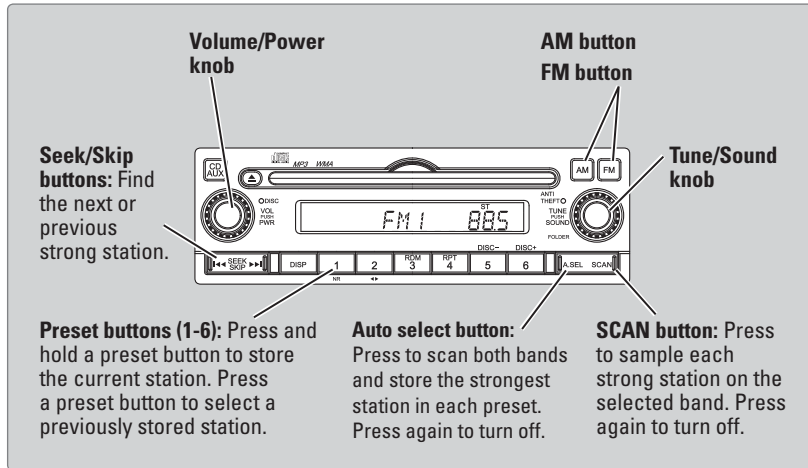

### Compact Disc (CD)

The audio system supports audio CDs, CD-Rs, and CD-RWs in MP3, WMA, or AAC formats.

#### Models with information display

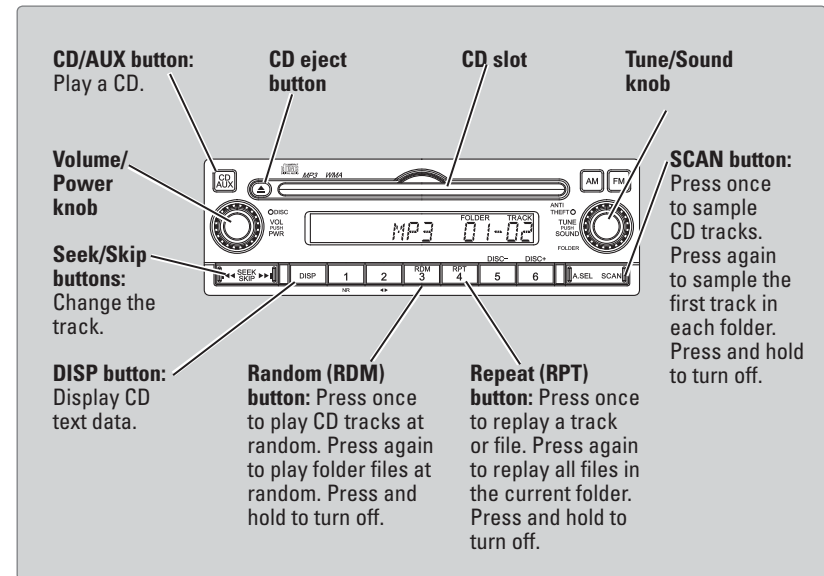

#### NOTICE

Do not use CDs with adhesive labels or insert a damaged CD. Inserting these types of CDs may cause them to get stuck or damage the audio unit.



### One Display Audio Operation

Control audio operation in the intelligent Multi-Information Display (i-MID) using the dashboard buttons.

#### Models with one display

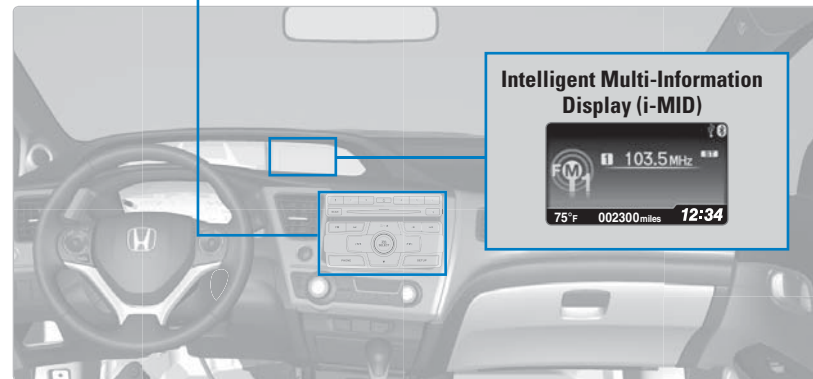
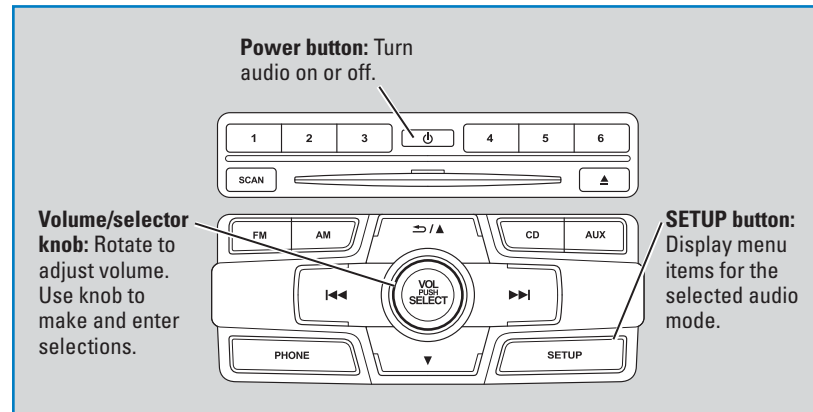

### FM/AM Radio

Play FM or AM radio stations.

#### Models with one display

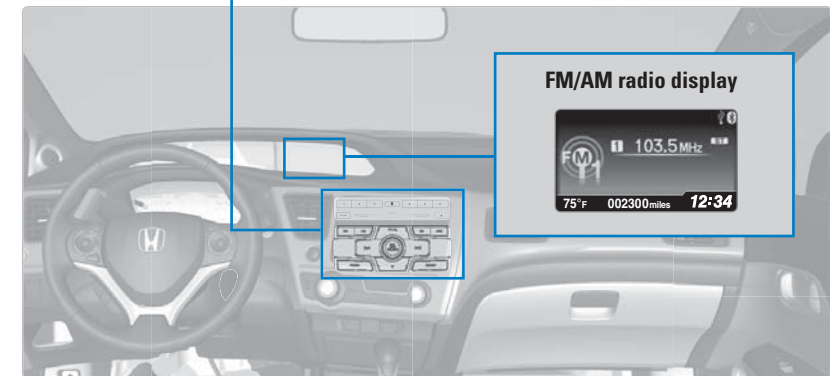
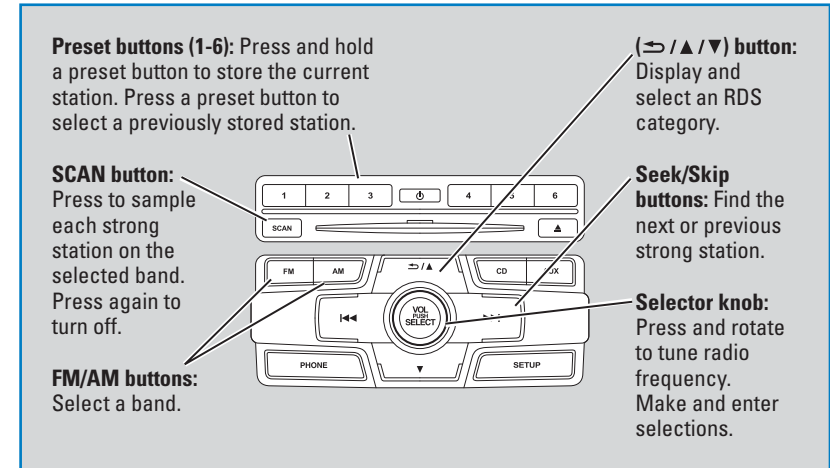

### Compact Disc (CD)

The audio system supports audio CDs, CD-Rs, and CD-RWs in MP3, WMA, or AAC formats.

#### Models with one display

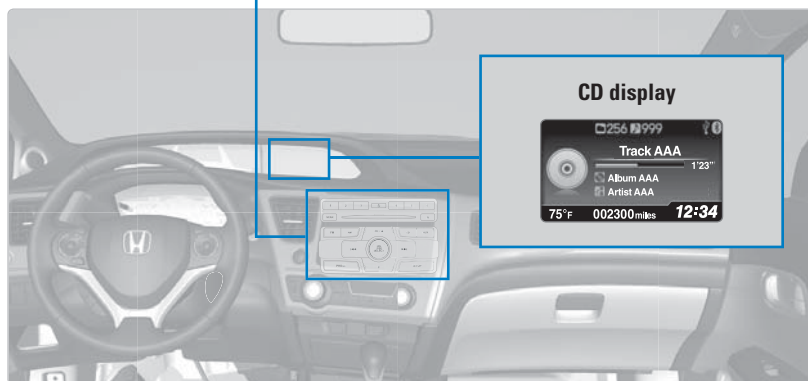
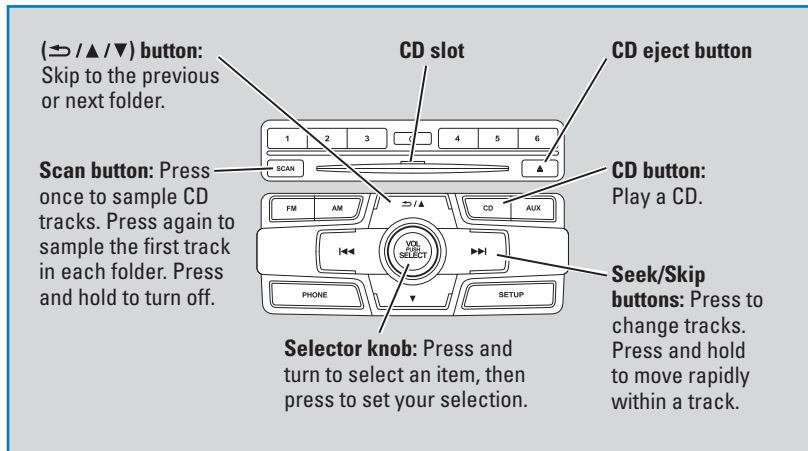

**NOTICE**

Do not use CDs with adhesive labels or insert a damaged CD. Inserting these types of CDs may cause them to get stuck or damage the audio unit.

### iPod®

Play and operate an iPod through the vehicle's audio system.

#### Models with one display

Connect your device to the USB port (see page 45).

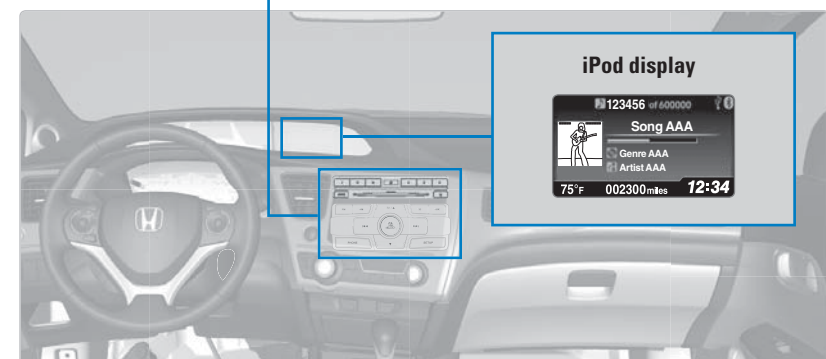
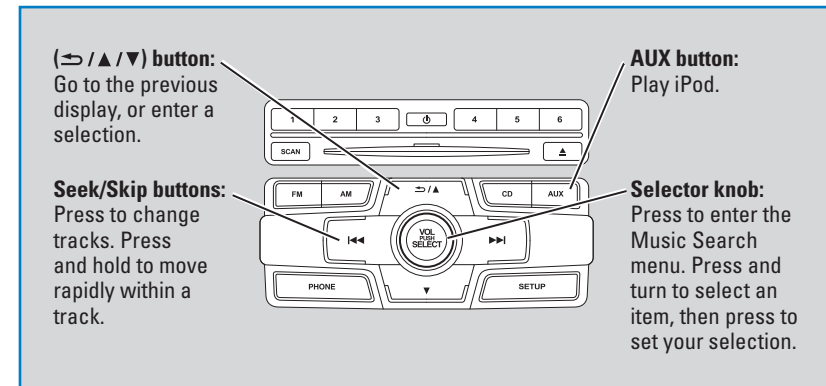

■ **Searching for Music**

Use the selector knob to search for tracks stored on the iPod.

1. From the audio screen, press the selector knob.
2. Select a menu option.
3. Select the track you want to play.

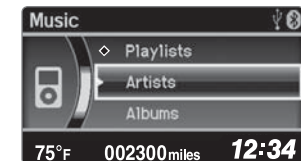

*iPod is a trademark of Apple, Inc.*

### USB Flash Drive

Play and operate a USB flash drive through the vehicle's audio system.

#### Models with one display

Connect your device to the USB port (see page 45).

**SCAN button:** Press once to sample tracks. Press again to sample the first track in each folder. Press and hold to turn off.

**AUX button:** Play a connected USB drive.

**Seek/Skip buttons:** Press to change tracks. Press and hold to move rapidly within a track.

**(▶/▲/▼) button:** Go to the next folder or beginning of the previous folder.

**Selector knob:** Press to enter the folder list. Press and turn to select an item, then press to set your selection.

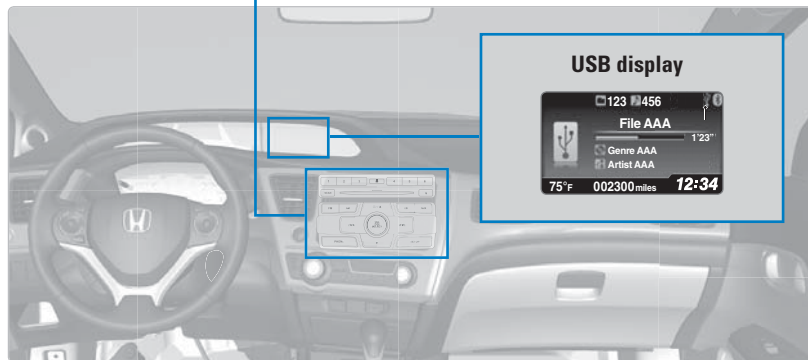

#### ■ Searching for Music

Use the selector knob to search for tracks stored on the USB flash drive.

1. From the audio screen, press the selector knob.
2. Select a folder.
3. Select the track you want to play.



### Bluetooth® Audio

Play streaming or stored audio from your compatible phone through the vehicle's audio system. Visit [handsfreelink.com](http://handsfreelink.com) (U.S.) or [handsfreelink.ca](http://handsfreelink.ca) (Canada) to check phone compatibility. Standard data rates apply.

#### Models with one display

Connect your phone to *Bluetooth*® HandsFreeLink® (see page 68).

**AUX button:** Play *Bluetooth*® Audio.

**Seek/Skip buttons:** Press to change tracks.

**Selector knob:** Press to display the device name.

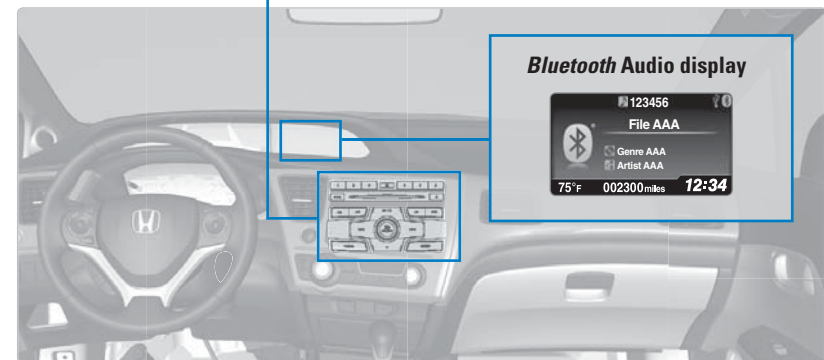

#### Notes:

- Make sure the volume on your phone is properly adjusted.
- You may need to enable additional settings on your phone for playback.
- The resume/pause function and remote audio controls are not supported on all phones.

*State or local laws may prohibit the operation of handheld electronic devices while operating a vehicle. Only launch streaming audio on your phone when it is safe to do so.*

### Pandora®

Play and operate Pandora from your phone through the vehicle's audio system. Visit [handsfreelink.com](http://handsfreelink.com) to check phone compatibility. Standard data rates apply.

**Available in the U.S. only.**

#### Models with one display

Connect your phone when the vehicle is stopped.

#### For iPhone:

- Connect via *Bluetooth*® HandsFreeLink® (see page 68) or USB port (see page 45).
- A pop-up may appear on your phone requesting you to allow access for Pandora to be launched.
- If you cannot operate Pandora through the audio system, it may be streaming through *Bluetooth*® Audio. Make sure Pandora is selected on the audio system.
- If Pandora still does not operate, try rebooting the phone and reconnecting the cable if necessary.

#### For Android or BlackBerry:

- Connect via *Bluetooth*® HandsFreeLink® (see page 68).

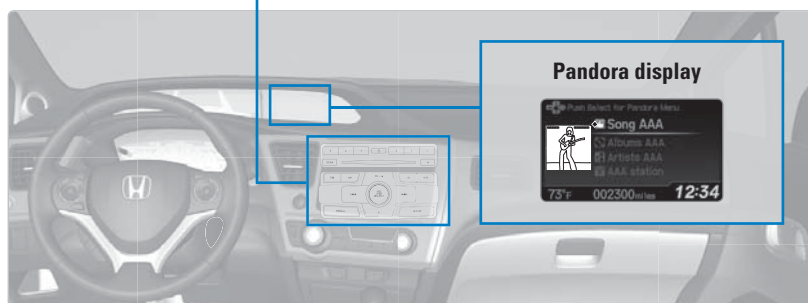
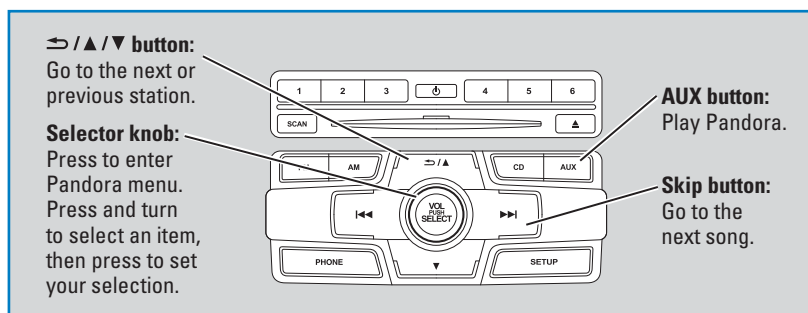

*State or local laws may prohibit the operation of handheld electronic devices while operating a vehicle. Only launch streaming audio on your phone when it is safe to do so.*

### Touchscreen Operation

Use simple gestures—including touching, swiping, and scrolling—to operate certain audio functions.

Some items may be grayed out during driving to reduce the potential for distraction. You can select them when the vehicle is stopped or use voice commands\*.

Wearing gloves may limit or prevent touchscreen response.

#### Models with touchscreen

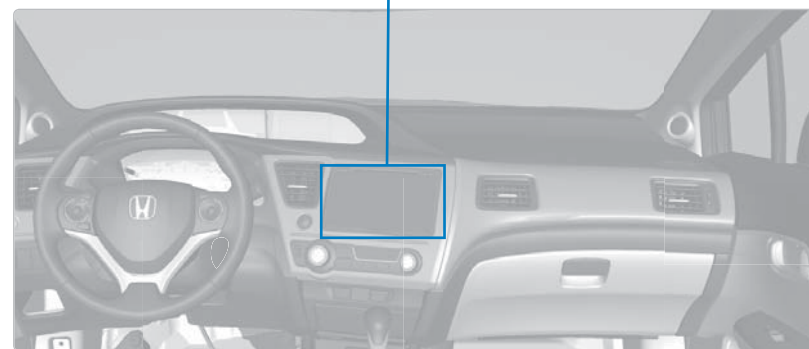
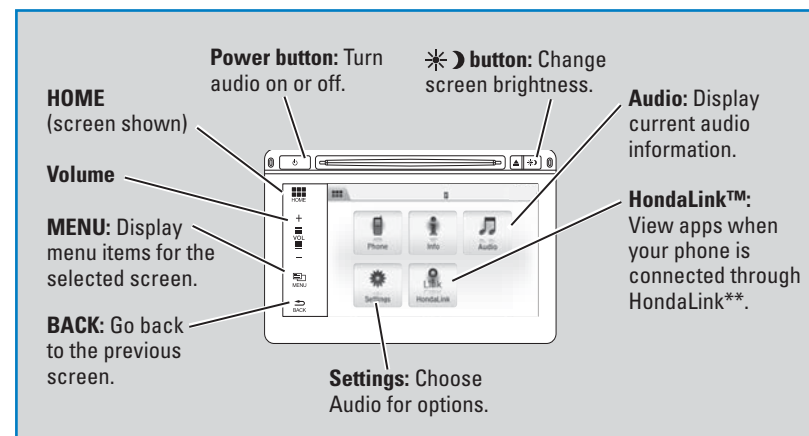

*\*if equipped*

**\*\*HondaLink can be accessed only if the app is installed on your smartphone, and the phone is connected to the system (see page 58).**

**Changing Icon Order**

You can change the order of the icons on the Home screen.

1. From the Home screen, select Settings.
2. Select System.
3. Select the Home tab.
4. Select Home Screen Edit Order.
5. Select and hold the icon you want to move and slide it to a different position.

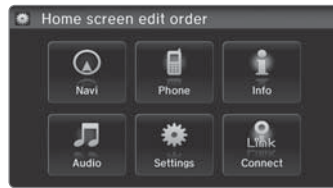

**HondaLink™**

You can connect a compatible smartphone to the audio system to enable integration between the smartphone's approved apps and the vehicle. This allows you to control the phone's apps through the touchscreen.

To check smartphone compatibility and connection instructions, visit [handsfreelink.honda.com](http://handsfreelink.honda.com).

To get more information on HondaLink features and apps, visit [www.hondalink.com](http://www.hondalink.com).

**FM/AM Radio**

Play FM or AM radio stations.

**Models with touchscreen**

**Source:** Select the FM or AM icon.

**Scan:** Scan for each station with a strong signal.

**Tune:** Change the station.

**Seek:** Search for the next or previous station with a strong signal.

**Open/close:** Display or hide the station list or preset list.

**Presets:** Select and hold a preset number to store the current station. Select a preset number to select a previously stored station.

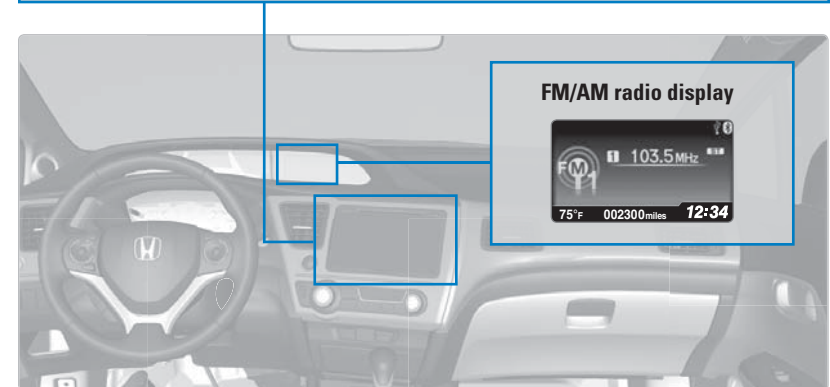

### SiriusXM® Radio

Available on a subscription basis only. For more information or to subscribe, contact your dealer, or visit [www.siriusxm.com](http://www.siriusxm.com) (U.S.) or [www.sirius.ca](http://www.sirius.ca) (Canada).

#### Models with touchscreen

**Source:** Select the XM icon.

**Scan:** Scan for each channel with a strong signal.

**Category:** Change the category.

**Channel:** Change the channel.

**Open/close:** Display or hide the channel list or preset list.

**Presets:** Select and hold a preset number to store the current channel. Select a preset number to select a previously stored channel.



Available in the U.S. and Canada, except Hawaii, Alaska, and Puerto Rico. XM® is a registered trademark of Sirius XM Radio, Inc.

### Compact Disc (CD)

The audio system supports audio CDs, CD-Rs, and CD-RWs in MP3, WMA, or AAC formats.

#### Models with touchscreen

**CD slot** **CD eject button**

**Source:** Select the CD icon.

**Open/close:** Display or hide the track list.

**Folder:** Change the folder.

**Track:** Change the track.

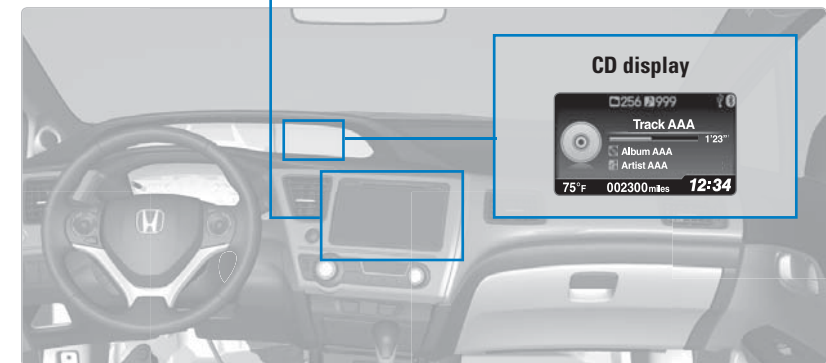

#### NOTICE

Do not use CDs with adhesive labels or insert a damaged CD. Inserting these types of CDs may cause them to get stuck or damage the audio unit.



### iPod®

Play and operate an iPod through the vehicle's audio system.

#### Models with touchscreen

Connect your device to the USB port (see page 45).

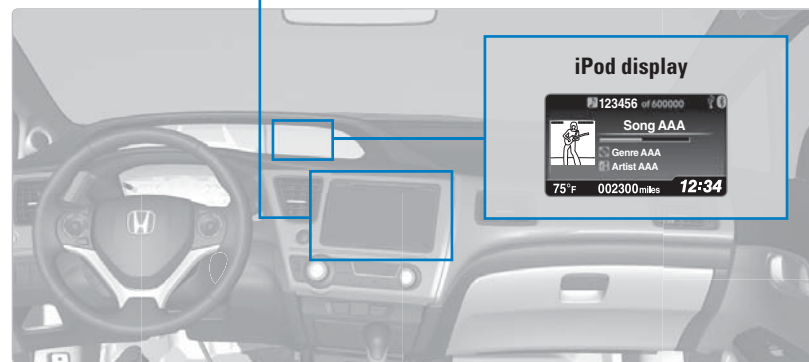
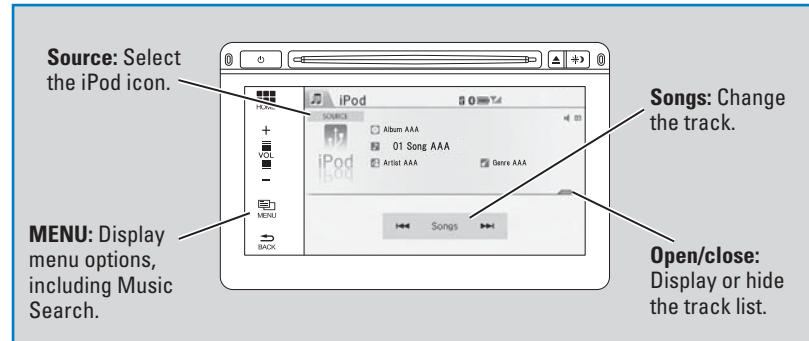

#### ■ Searching for Music

Use the touchscreen to search for tracks stored on the iPod.

1. From the audio screen, press MENU.
2. Select Music Search.
3. Select a search option.
4. Select the track you want to play.



### USB Flash Drive

Play and operate a USB flash drive through the vehicle's audio system.

#### Models with touchscreen

Connect your device to the USB port (see page 45).

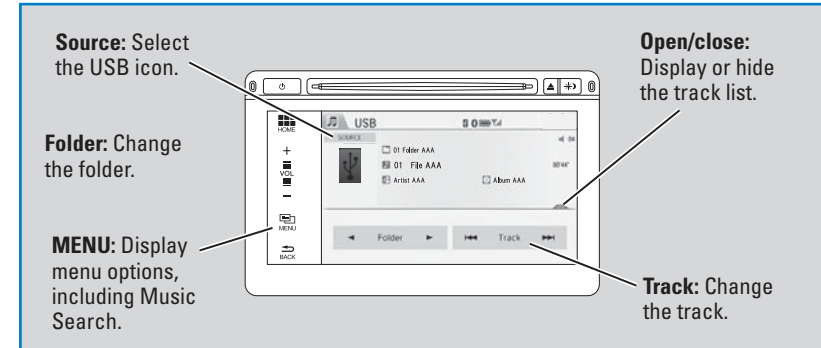

#### ■ Searching for Music

Use the touchscreen to search for tracks stored on the USB flash drive.

1. From the audio screen, press MENU.
2. Select Music Search.
3. Select a folder.
4. Select the track you want to play.





### Bluetooth® Audio

Play streaming or stored audio from your compatible phone through the vehicle's audio system. Visit [handsfreelink.com](http://handsfreelink.com) (U.S.) or [handsfreelink.ca](http://handsfreelink.ca) (Canada) to check phone compatibility. Standard data rates apply.

#### Models with touchscreen

Connect your phone to **Bluetooth® HandsFreeLink®** (see page 73).

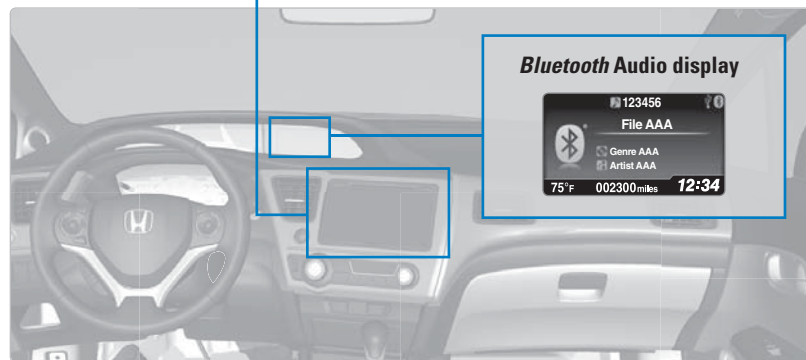
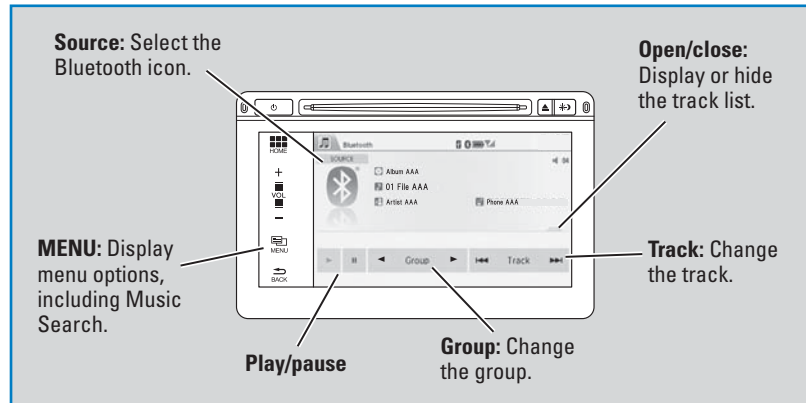

#### Notes:

- Make sure the volume on your phone is properly adjusted.
- You may need to enable additional settings on your phone for playback.
- The resume/pause function and remote audio controls are not supported on all phones.

*State or local laws may prohibit the operation of handheld electronic devices while operating a vehicle. Only launch streaming audio on your phone when it is safe to do so.*

### Pandora®

Play and operate Pandora from your compatible phone through the vehicle's audio system. Visit [handsfreelink.com](http://handsfreelink.com) to check phone compatibility. Standard data rates apply. **Available in the U.S. only.**

#### Models with touchscreen

Connect your phone when the vehicle is stopped.

#### For iPhone:

- Connect via **Bluetooth® HandsFreeLink®** (see page 73) or USB port (see page 45).
- A pop-up may appear on your phone requesting you to allow access for Pandora to be launched.
- If you cannot operate Pandora through the audio system, it may be streaming through **Bluetooth® Audio**. Make sure Pandora is selected on the audio system.
- If Pandora still does not operate, try rebooting the phone and reconnecting the cable if necessary.

#### For Android or BlackBerry:

- Connect via **Bluetooth® HandsFreeLink®** (see page 73).

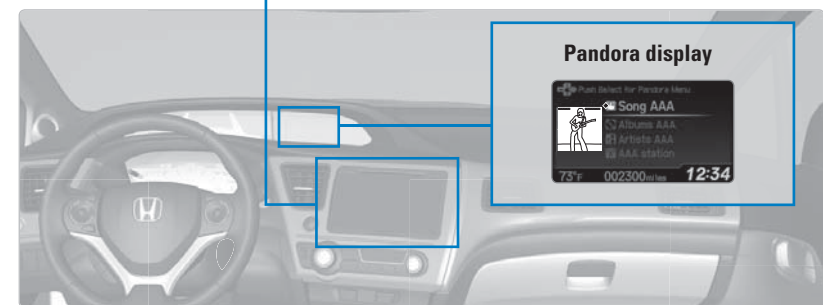
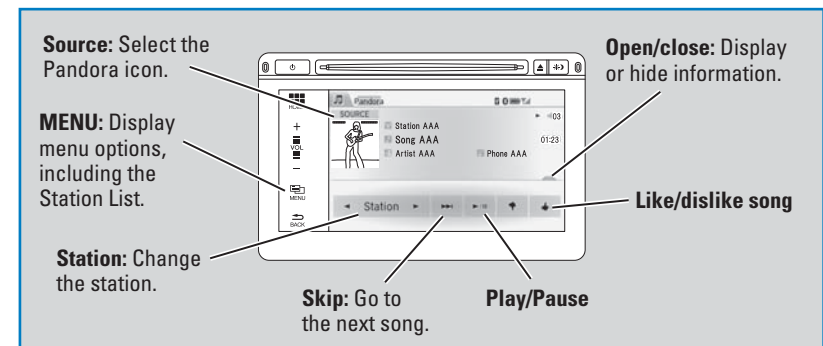

*State or local laws may prohibit the operation of handheld electronic devices while operating a vehicle. Only launch streaming audio on your phone when it is safe to do so.*

### HDMI Video

Play video from a compatible device through your vehicle.

#### Models with touchscreen

Connect your device to the HDMI port (see page 45). From the connected device, launch the video you want to display on the touchscreen. This feature is limited while the vehicle is moving.

The device or video resolution must be 720p or lower to view in the touchscreen.

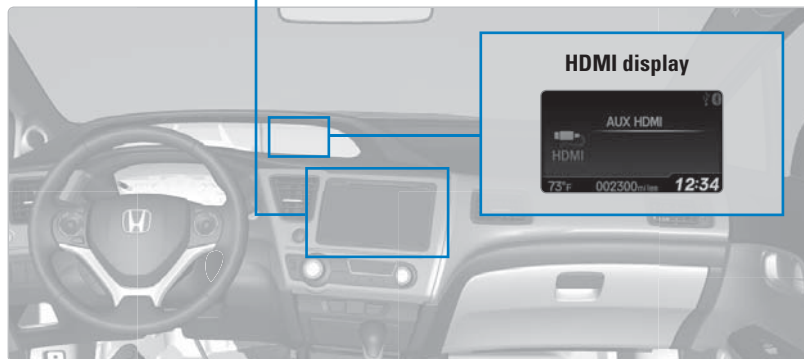
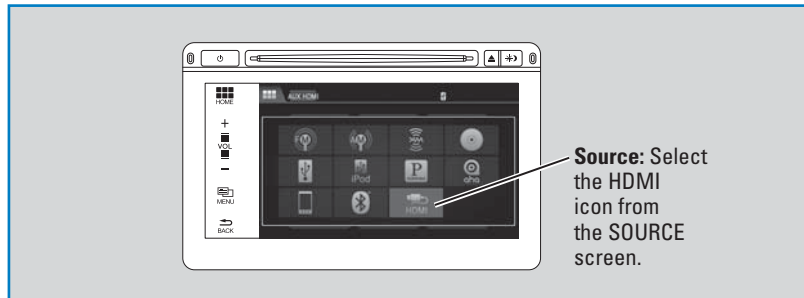

Additional cables and accessories sold separately.

## BLUETOOTH® HANDSFREELINK® (HFL)

Learn how to operate the vehicle's hands-free calling system.

### Basic HFL Operation

Make and receive phone calls using the vehicle's audio system, without handling your phone. Visit [handsfreelink.com](http://handsfreelink.com) (U.S.) or [handsfreelink.ca](http://handsfreelink.ca) (Canada) to check phone compatibility.

**To reduce the potential for driver distraction, certain manual functions may be inoperable or grayed out while the vehicle is moving. Stop or pull over to perform the function.**

#### Models with one display

##### ■ HFL Controls

Use the controls to enter information and make selections.

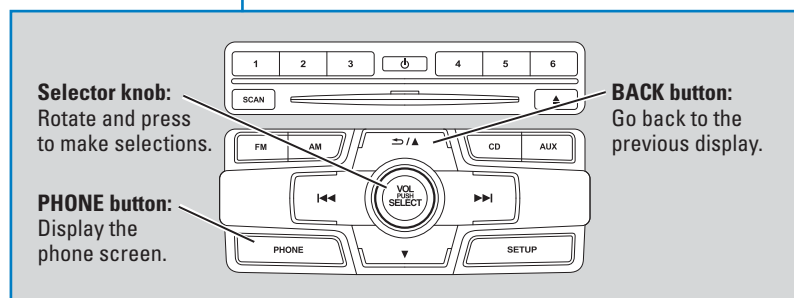
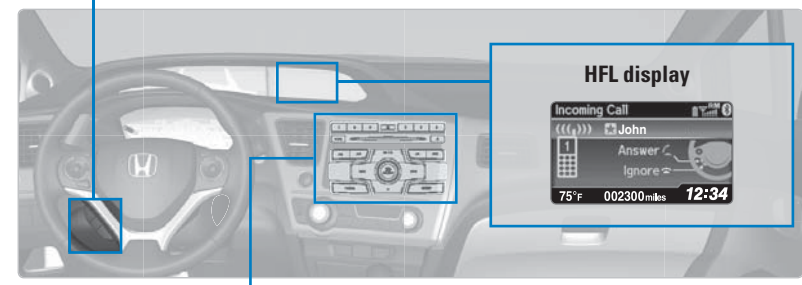
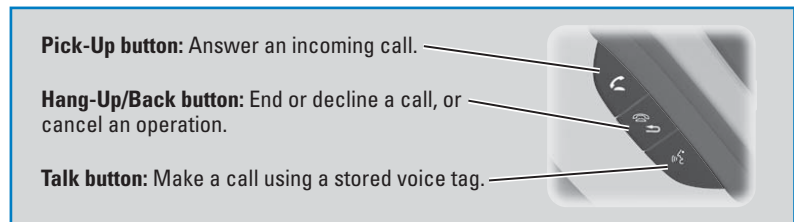

Models with one display

**Pairing a Phone**

To use hands-free phone and streaming audio functions, you must first pair your phone to the system. This can only be done when the vehicle is stopped. Use the selector knob to make and enter selections.

■ **Pairing the First Phone**

1. Press PHONE to go to the Phone screen. A prompt appears. Select Yes.
2. Make sure your phone is in discovery mode. Select OK.
3. HFL searches for your phone. Select your phone when it appears on the list.  
*If your phone does not appear:* Select Phone Not Found and search for HandsFreeLink from your phone. Connect to HFL.
4. HFL gives you a four-digit code. Compare it to the code that appears on your phone. Connect to HFL from your phone.

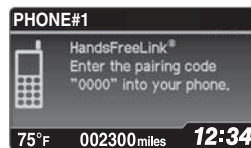

■ **Pairing an Additional Phone**

1. Press PHONE to go to the Phone screen. If a prompt appears asking to connect to a phone, select No.
2. Select Phone Setup.
3. Select Connection.
4. Select Add a New Phone.
5. Select an empty location for the phone.
6. Make sure your phone is in discovery mode. Select OK.
7. HFL searches for your phone. Select it when it appears on the list.  
*If your phone does not appear:* Select Phone Not Found, and search for HandsFreeLink from your phone. Connect to HFL.
8. HFL gives you a four-digit code. Enter it on your phone when prompted.

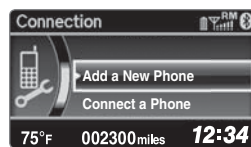
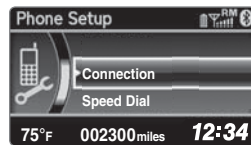

*State or local laws may prohibit the operation of handheld electronic devices while operating a vehicle.*

Models with one display

**Making a Call**

You can make a call using several methods.

■ **Dialing a Number**

Enter a 10-digit phone number to call. Use the selector knob to make and enter selections. This method is inoperable while the vehicle is moving.

1. Press PHONE.
2. Select Dial.
3. Enter the phone number. Select the green phone icon to call.



■ **Using the Phonebook**

When your phone is paired, its entire phonebook can be automatically imported to the system. Use the selector knob to make and enter selections. This method is inoperable while the vehicle is moving.

1. Press PHONE.
2. Select Phonebook.
3. Scroll through the list to find the name and number you want to call, and select it to call.



■ **Storing Speed Dial Entries**

Store up to 20 numbers for quick dialing. Use the selector knob to make and enter selections.

1. Press PHONE.
2. Select Phone Setup
3. Select Speed Dial, then select Add New.
4. Select an entry method.
5. If desired, you can create a voice tag for the number. Follow the prompts.

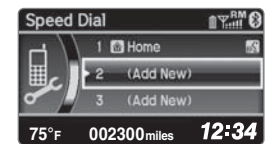

■ **Using Speed Dial**

Make calls quickly using stored speed dial entries. Use the selector knob to make and enter selections.

1. Press PHONE.
2. Select Speed Dial.
3. Scroll through the list to find the entry you want to call, and select it to call.

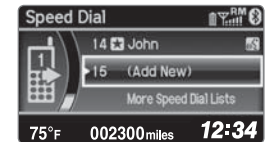

Speed dial entries with stored voice tags can be called using the Talk button. Press the Talk button and follow the prompts.

Models with one display

**SMS Text Messaging**

Receive and send messages from your paired and connected phone. Visit *handsfreelink.com* (U.S.) or *handsfreelink.ca* (Canada) to check phone compatibility. Standard message rates apply. This feature is limited while the vehicle is moving.

■ **Receiving and Responding to Messages**

When you receive a new message, a pop-up appears on the display. Use the selector knob to view the message when the vehicle is stopped. You can also reply to it using fixed phrases or call the sender.

1. When the prompt appears, select Yes.
2. The message is displayed, and the system reads it aloud.



*To reply:* With the message open, press the selector knob to enter the Text Message Menu. Select Reply, and choose one of the six available responses. Select Yes to send the message. You cannot create a new text message.

*To call the sender:* With the message open, press the selector knob to enter the Text Message Menu. Select Call.

**Basic HFL Operation**

Make and receive phone calls using the vehicle’s audio system, without handling your phone. Visit *handsfreelink.com* (U.S.) or *handsfreelink.ca* (Canada) to check phone compatibility.

**To reduce the potential for driver distraction, certain manual functions may be inoperable or grayed out while the vehicle is moving. Stop or pull over to perform the function. Voice commands are also available.**

Models with touchscreen

■ **HFL Controls**

Use the controls to enter information and make selections.

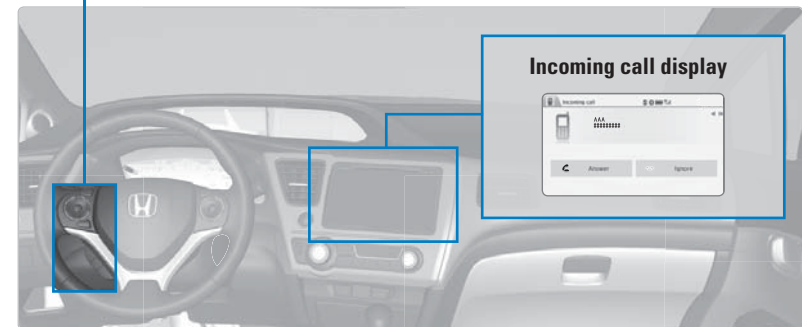
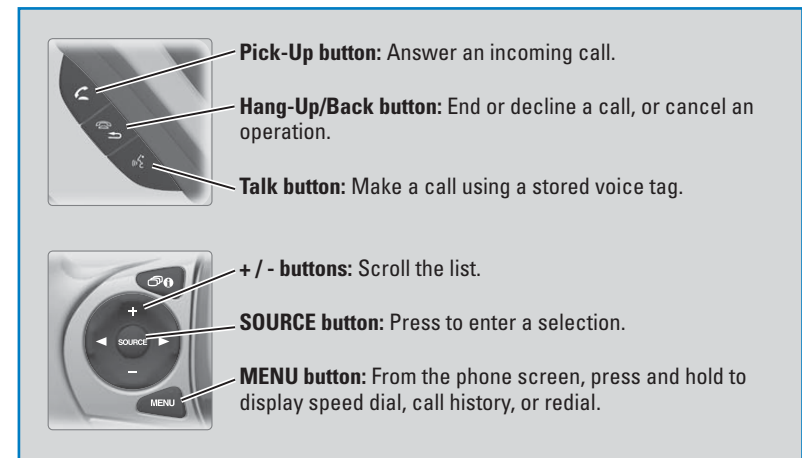

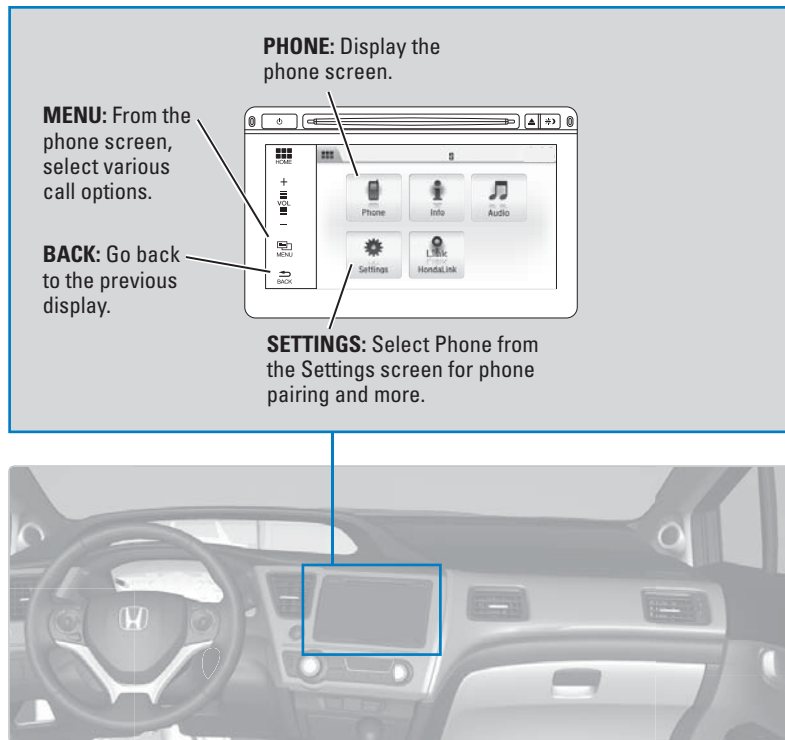

**Voice Recognition Tips**

- When using the Talk button, wait for a beep before saying a command.
- To bypass the system prompts, simply press the Talk button again to say your command.
- When the Talk button is pressed, all available voice commands are highlighted in yellow.
- Speak in a clear, natural voice.
- Reduce all background noise.
- Adjust the dashboard and side vents away from the microphone in the ceiling.
- Close the windows and moonroof.

**Models with touchscreen**

**Pairing a Phone**

To use hands-free phone and streaming audio functions, you must first pair your phone to the system. This can only be done when the vehicle is stopped. Use the touchscreen to make and enter selections.

1. From the Home screen, select Settings.
2. Select Phone.
3. Select Bluetooth Device List
4. Select Add Bluetooth Device.
5. Make sure your phone is in discovery mode. Select OK.
6. HFL searches for your phone. Select your phone when it appears on the list.  
*If your phone does not appear:* Select Phone Not Found and search for HandsFreeLink from your phone. Connect to HFL.
7. HFL gives you a six-digit code. Compare it to the code that appears on your phone. Connect to HFL from your phone.
8. The system asks if you want to enable options:  
*HondaLink Assist:* Select On to enable emergency collision notification (see page 77).  
*Phone Synchronization:* Select On to automatically import contacts and call history from your phone.
9. Press BACK to exit the menu.



*State or local laws may prohibit the operation of handheld electronic devices while operating a vehicle.*

Models with touchscreen

**Making a Call**

You can make a call using several methods.

**Dialing a Number**

Enter a 10-digit phone number to call.

**Using voice commands**

Press the Talk button before you say each command.

1. Say "Call by number."
2. Say the phone number: For example, "3-1-0-5-5-5-1-2-3-4."
3. The system begins to dial.



**Using the touchscreen**

Manual operation is limited while the vehicle is moving. Voice commands are always available.

1. From the Home screen, select Phone.
2. Select MENU.
3. Select Dial.
4. Enter the phone number. Select the green phone icon to call.

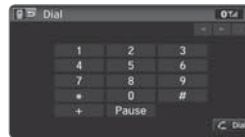

**Using the Phonebook**

When your phone is paired, its entire phonebook can be automatically imported to the system. Phone synchronization must be turned on.

**Using voice commands**

Press the Talk button before you say each command.

1. Say "Call by name."
2. Say the phonebook name and phone type. For example, "John Smith mobile."



**Using the touchscreen**

Manual operation is limited while the vehicle is moving. Voice commands are always available.

1. From the Home screen, select Phone.
2. Select MENU.
3. Select Phonebook.
4. Scroll through the list to find the name and number you want to call, and select it to call.

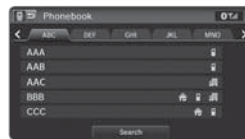

**Storing Speed Dial Entries**

Store up to 20 numbers for quick dialing.

1. From the Home screen, select Phone.
2. Select MENU.
3. Select Edit Speed Dial, then select New Entry.
4. Select an entry method.
5. If desired, you can create a voice tag for the number. Follow the prompts.

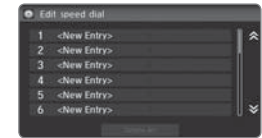

**Using Speed Dial**

Make calls quickly using stored speed dial entries.

**Using voice commands**

Press the Talk button before you say each command.

1. Say "Dial by name."
2. Say the stored voice tag name. For example, "John Smith."



**Using the touchscreen**

1. From the Home screen, select Phone.
2. Scroll through the list to find the entry you want to call, and select it to call.





Models with touchscreen

**SMS Text Messaging and E-Mail\***

Receive and send messages from your paired and connected phone. Visit [handsfreelink.honda.com](http://handsfreelink.honda.com) (U.S.) or [www.handsfreelink.ca](http://www.handsfreelink.ca) (Canada) to check phone compatibility. Standard message rates apply. This feature is limited while the vehicle is moving.

**Receiving and Responding to Messages**

When you receive a new message, a pop-up appears on the touchscreen. You can view the message when the vehicle is stopped. You can also reply to it using fixed phrases or call the sender.

1. When the prompt appears, select Read.
2. The message is displayed, and the system reads it aloud.

*To reply:* With the message open, select Reply, and choose one of the six available responses. Select Send to send the message. You cannot create a new text message.

*To call the sender:* With the message open, select Call.



**Selecting an Account**

If your phone has both text message and e-mail accounts, you can select only one of them at a time to be active and receive notifications.

1. From the Home screen, select Settings.
2. Select Phone.
3. Select Select Account.
4. Select Text Message or an e-mail account.

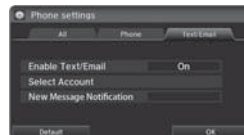

\*if equipped

Models with touchscreen

**HondaLink™ Assist**

Automatically connect and talk to an operator who can locate your vehicle and send emergency help in the event of a collision. Visit [www.hondalink.com](http://www.hondalink.com) (U.S.) or [honda.ca/hondalinkassist](http://honda.ca/hondalinkassist) (Canada) for more information.

1. Make sure your phone is on and paired to Bluetooth® HandsFreeLink® (see page 73).
2. Select Call Now, or the system automatically connects after 10 seconds. The vehicle information and its position are sent to the operator.
3. Select Talk Now to immediately talk to the operator.
4. When the call is complete, select Hang Up or press the Hang Up/Back button on the steering wheel.



**Siri™ Eyes Free**

Activate Siri through your vehicle when an iPhone® is paired to the system. Visit [handsfreelink.honda.com](http://handsfreelink.honda.com) (U.S.) or [honda.ca/siri](http://honda.ca/siri) (Canada) to check phone compatibility.

**Hang-Up/Back button:** Exit Siri Eyes Free mode, or cancel a command.

**Talk button:** Press and hold to activate Siri Eyes Free mode. The Smartphone screen appears. Say your command after you hear the Siri tone. If you only press and release the Talk button, the standard voice recognition system is activated.

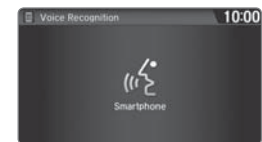

Here are some examples of Siri commands:

- |                                  |                                    |
|----------------------------------|------------------------------------|
| "Call John Smith"                | "Remind me to pick up dinner"      |
| "Read my new text message"       | "Set up a meeting today at 3 p.m." |
| "Find a nearby sushi restaurant" | "Play song XYZ"                    |

**Notes:**

- Any requests that include visual feedback from Siri on your phone are not displayed in the vehicle.
- Certain commands rely on the iPhone's features and existing apps.
- To hear turn-by-turn directions or songs through the vehicle, set the audio source to Bluetooth® Audio.

Siri and iPhone are trademarks of Apple, Inc.



# NAVIGATION\*

Learn how to enter a destination and operate the navigation system.

## Basic Navigation Operation

A real-time navigation system uses GPS and a map database to show your current location and help guide you to a desired destination. You can operate the system using voice commands or the touchscreen.

**To reduce the potential for driver distraction, certain manual functions may be inoperable or grayed out while the vehicle is moving. Voice commands are always available.**

### Steering Wheel Controls

Use the steering wheel controls to control the system.

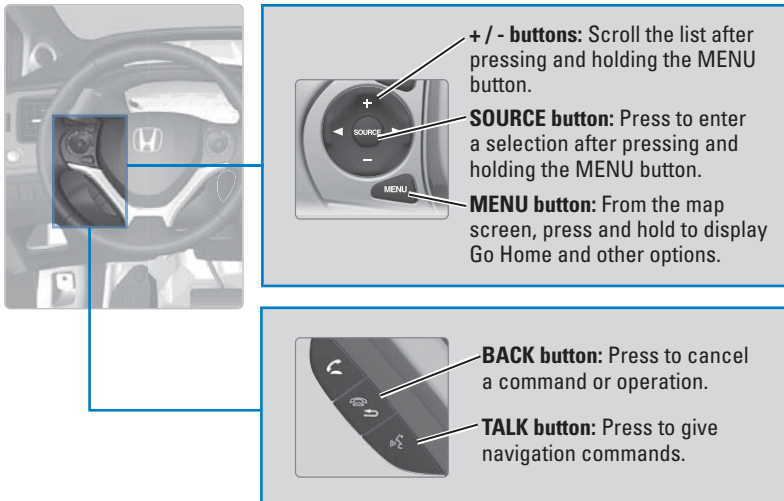

### ⚠️ WARNING

Using the navigation system while driving can take your attention away from the road, causing a crash in which you could be seriously injured or killed. Operate system controls only when the conditions permit you to safely do so.

### Navigation Display and Controls

Use the touchscreen to enter information and make selections.

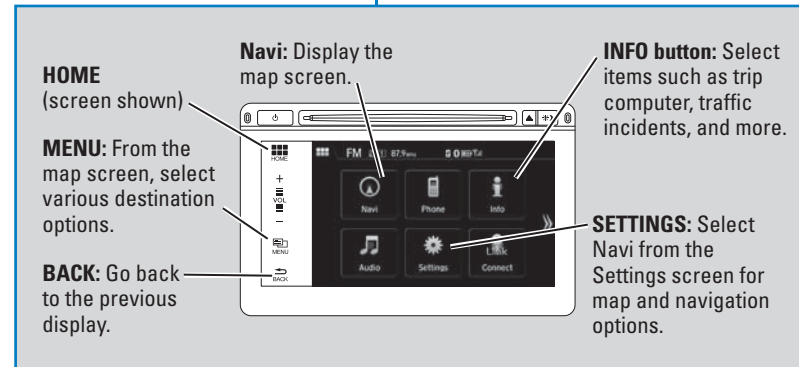
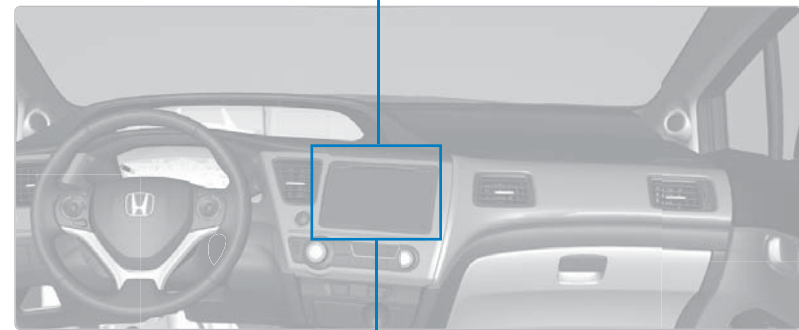
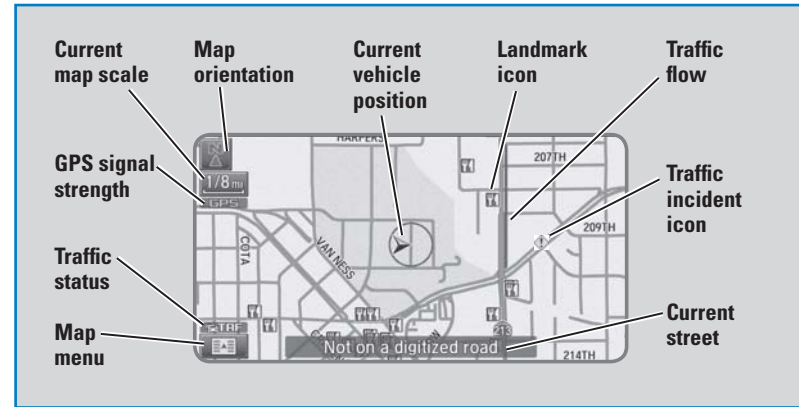

**■ Voice Prompt Volume**

Adjust volume for navigation and voice command confirmation. This does not affect audio or *Bluetooth*® HandsFreeLink® volume, which is controlled by the volume bar.

1. From the Home Screen, select Settings.
2. Select System.
3. Select Volume.
4. Adjust the level, or select off.



**■ Voice Prompt**

Turn the voice feedback feature on or off.

1. From the Home screen, select Settings.
2. Select System.
3. Select Voice Prompt.
4. Select On or Off.



**■ Voice Recognition Tips**

- When using the Talk button, wait for a beep before saying a command.
- To bypass the system prompts, simply press the Talk button again to say your command.
- When the Talk button is pressed, all available voice commands are highlighted in yellow.
- Speak in a clear, natural voice.
- Reduce all background noise.
- Adjust the dashboard and side vents away from the microphone in the ceiling.
- Close the windows and moonroof.

**Entering a Destination**

Use multiple methods to enter a destination.

**■ Home Address**

Store your home address in the system so you can easily route to it.

1. From the Home screen, select Settings.
2. Select Navigation.
3. Select Edit Go Home (1 or 2).
4. Enter the address, and select OK when complete.



When your home address is stored, you can press the Talk button and say “Go home” at any time. You can also select Go home from the navigation menu.

**■ Street Address**

Enter a street address using voice commands. Press the Talk button before saying each command.

You can also enter the address manually when the vehicle is stopped. From the map screen, press MENU and select Address. Follow the prompts.

**U.S. models**

1. From the Voice Portal screen, say “Address.”
2. The system prompts you to say the entire address. For example, say “1-2-3-4 Main Street, Los Angeles, California.”
3. The system interprets the address by state, city, street, and address number. If necessary, you may have to clarify similar matches.
4. Say “Set as destination” to set the route.



**Canadian models**

1. From the Voice Portal screen, say “Address.”
2. Follow the prompts.

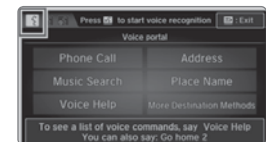

**Place Category**

Enter a destination or point of interest using voice commands. Press the Talk button before saying each command.

You can also enter the place name manually when the vehicle is stopped. From the map screen, press MENU and select Place Name. Follow the prompts.

1. From the Voice Portal screen, say "Place name."
2. Say a category, for example "ATM/Bank."
3. Say the name of the place, for example "ABC Bank."
4. The system interprets the name. If necessary, you may have to clarify similar matches.
5. Say "Set as destination" to set the route.



**Find Nearest Place**

Enter a destination by category and distance using voice commands. Press the Talk button before saying each command.

1. Say "Find nearest" and a place. For example, "Find nearest ATM."
2. A list of the nearest places in your area is displayed by shortest distance to destination.
3. Say the number next to the destination you want to select.
4. Say "Set as destination" to set the route.



**Routing**

After a destination is set, you can alter or cancel your route.

**Map Legend**

**Turn-by-Turn Directions**  
Shows a more detailed view of the next maneuver on the i-MID.

**Distance to next maneuver** 700 feet

**Current route**

**Upcoming maneuver** Then

2:36

**During route guidance**

**Estimated time to destination** 1:20

**Distance to destination** 0.09 mi

**Next guidance point** 24TH ST

**Calculated route**

**■ Taking a Detour**

You can calculate a detour route manually if you encounter a road closure or other obstacle.

1. When en route, press MENU from the map screen.
2. Select Detour. The system attempts to calculate a new route by avoiding the next 5 miles (8 km) while on a freeway or 1 mile (1 km) while on a surface street.



**■ Traffic**

View traffic flow, incidents, and construction in major metro areas. You can also route around congestion or incidents using voice commands. Press the Talk button before saying each command. **Available on U.S. models only.**

1. When en route, say "Display traffic incidents." A list of incidents on your route appears.
2. Say the number of the incident you want to avoid.
3. Say "Avoid" and the incident list returns.
4. Say "Recalculate route" to set the new route.



**■ Canceling Your Route**

You can cancel your route at any time.

1. When en route, press MENU from the map screen.
2. Select Cancel Route. The route is cleared and the map screen returns. You can also press the Talk button and say "Cancel route."

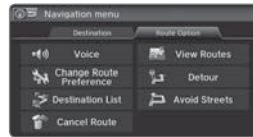

# DRIVING

Learn about preparation for driving, as well as other features.

**Before Driving**

Check the following items before you begin driving.

**■ Exterior Checks**

- Make sure there are no obstructions on the windows, door mirrors, exterior lights, or other parts of the vehicle.
- Remove any frost, snow, or ice.
- Make sure the hood is securely closed.
- Heat from the engine and exhaust can ignite flammable materials left under the hood, causing a fire. If you've parked your vehicle for an extended period, inspect and remove any debris that may have collected, such as dried grass and leaves that have fallen or have been carried in for use as a nest by a small animal. Also check under the hood for leftover flammable materials after you or someone else has performed maintenance on your vehicle.
- Make sure the tires are in good condition.
- Make sure there are no people or objects behind or around the vehicle.

**NOTICE**

If the doors are frozen shut, use warm water around the door edges to melt any ice. Do not try to force them open, as this can damage the rubber trim around the doors. When done, wipe dry to avoid further freezing.

**■ Interior Checks**

- Store or secure all items on board properly.
- Do not pile items higher than the seat height.
- Do not place anything in the front seat footwells. Make sure to secure the floor mats.
- If you have any animals on board, do not let them move freely around in the vehicle.
- Securely close and lock all doors and the trunk.
- Adjust your seating position, mirrors, and steering wheel properly.
- Make sure items placed on the floor behind the front seats cannot roll under the seats.
- Everyone in the vehicle must fasten their seat belt.
- Make sure that the indicators in the instrument panel come on when you start the vehicle, and go off soon after.

In addition:

- During the first 600 miles (1,000 km) of operation, avoid sudden acceleration or full throttle operation so as not to damage the engine or powertrain.
- Avoid hard braking for the first 200 miles (300 km). You should also follow this when the brake pads are replaced.

**Natural Gas (CNG) models**

Do not put large, heavy, or pointed objects in the trunk. When storing items, properly secure them so that they do not move around while driving. The fuel tank is located in the trunk, and although a partition separates the tank from the cargo space, large items or loose items can damage the fuel tank and fuel system components.

**⚠ WARNING**

Improper accessories or modifications can affect your vehicle’s handling, and stability, and performance, and cause a crash in which you can be seriously hurt or killed.

Follow all instructions in the vehicle owner’s manual regarding accessories and modifications.

**Maximum Load Limit**

Carrying too much cargo or improperly storing it can affect your vehicle’s handling, stability, stopping distance, and tires, and make it unsafe.

The maximum load for your vehicle is 850 lbs (385 kg). See the Tire and Loading Information label on the driver’s doorjamb.

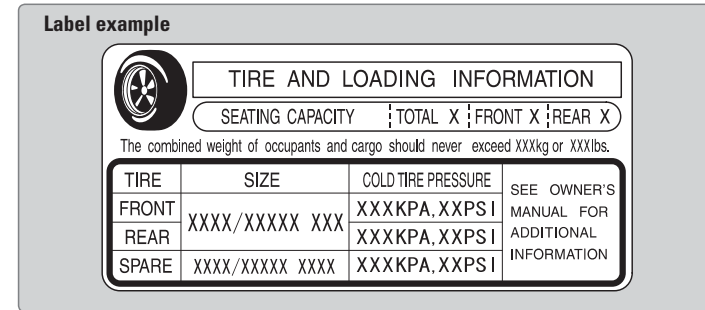

This figure includes the total weight of all occupants, cargo, and accessories, and the tongue load if you are towing a trailer. Below are the steps for determining the correct load limit:

1. Locate the statement “The combined weight of occupants and cargo should never exceed XXX kg or XXX lbs.” on your vehicle’s placard.
2. Determine the combined weight of the driver and passengers that will be riding in your vehicle.
3. Subtract the combined weight of the driver and passengers from XXX kg or XXX lbs.
4. The resulting figure equals the available amount of cargo and luggage load capacity. For example, if the “XXX” amount equals 1,400 lbs. and there will be five 150 lb. passengers in your vehicle, the amount of available cargo and luggage load capacity is 650 lbs. (1,400 - 750 (5 x 150) = 650 lbs.)
5. Determine the combined weight of luggage and cargo being loaded on the vehicle. That weight may not safely exceed the available cargo and luggage load capacity calculated in step 4.
6. If your vehicle will be towing a trailer, load from your trailer will be transferred to your vehicle. Consult the Owner’s Manual on the Owner Information CD or at [owners.honda.com](http://owners.honda.com) (U.S.) or [myhonda.ca](http://myhonda.ca) (Canada) to determine how this reduces the available cargo and luggage load capacity of your vehicle.

In addition, the total weight of the vehicle, all occupants, accessories, cargo, and trailer tongue load must not exceed the Gross Vehicle Weight Rating (GVWR) or the Gross Axle Weight Rating (GAWR). Both are on a label on the driver’s doorjamb.

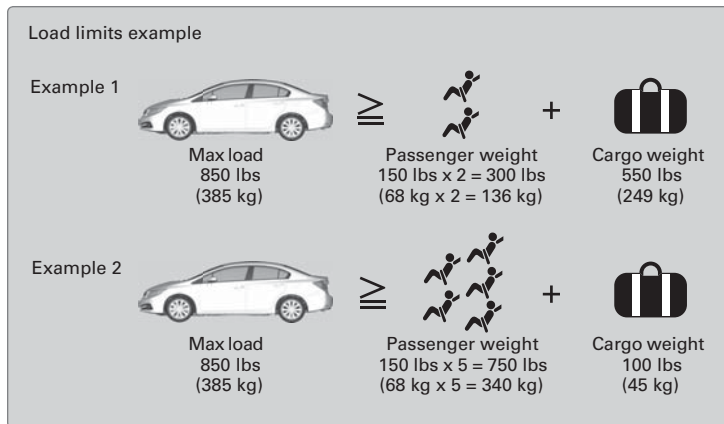

### ⚠️ WARNING

Overloading or improper loading can affect handling and stability and cause a crash in which you can be hurt or killed.

Follow all load limits and other loading guidelines in this guide.

The headlight aim on your vehicle was set by the factory, and does not need to be adjusted. However, if you regularly carry heavy items in the cargo area or pull a trailer, have the aiming readjusted at your dealer or by a qualified technician.

## Towing a Trailer

Your vehicle can tow a trailer if you carefully observe the load limits, use the proper equipment, and follow the towing guidelines. Check the load limits before driving (see page 87).

**Civic HF, Coupe, and Natural Gas (CNG) models are not designed to tow a trailer. Attempting to do so can void your warranties.**

### ■ Total Trailer Weight

Maximum allowable weight of the trailer, cargo, and everything in or on it must not exceed 1,000 lbs (450 kg). Towing loads in excess of this can seriously affect vehicle handling and performance and can damage the engine and drivetrain.

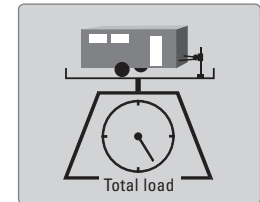

### ■ Tongue Load

The weight of the tongue with a fully loaded trailer on the hitch should be approximately 10% of the total trailer weight.

- Excessive tongue load reduces front tire traction and steering control. Too little tongue load can make the trailer unstable and cause it to sway.
- To achieve a proper tongue load, start by loading 60% of the load toward the front of the trailer and 40% toward the rear. Readjust the load as needed.

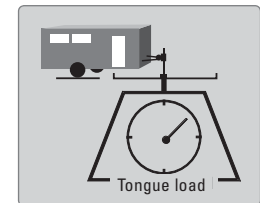

### ■ Pre-tow Checklist

When preparing to tow, and before driving away, ensure the following:

- The vehicle has been properly serviced, and the suspension and the cooling system are in good operating condition.
- Avoid towing a trailer during your vehicle's first 600 miles (1,000 km).
- The trailer has been properly serviced and is in good condition.
- All weights and loads are within limits. Never exceed the gross weight ratings.
- Check if all loads are within limits at a public scale. If a public scale is not available, add the estimated weight of your cargo load to the weight of your trailer (as quoted by the manufacturer) and the tongue load.
- The hitch, safety chains, and any other attachments are secure.
- All items in or on the trailer are properly secured and cannot shift while you drive.

### ⚠️ WARNING

Exceeding any load limit or improperly loading your vehicle and trailer can cause a crash in which you can be seriously hurt or killed.

Check the loading of your vehicle and trailer carefully before starting to drive.



## Starting to Drive

Turn on the vehicle and start the engine to begin driving.

### ■ Before Starting the Engine

#### Continuously Variable Transmission (CVT)

Check that the shift lever is in Park (P), then press the brake pedal. Keep your foot firmly on the brake pedal when starting the engine.

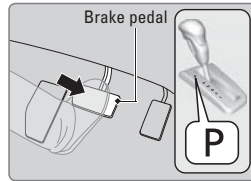

#### Manual transmission

Check that the shift lever is in Neutral (N), then press the brake pedal with your right foot and the clutch pedal with your left foot. The clutch must be fully pressed to start the engine.

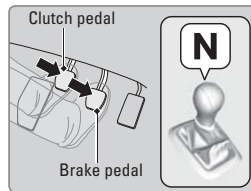

The engine is harder to start in cold weather and in thinner air found at altitudes above 8,000 feet (2,400 m). When starting the engine in cold weather, turn off all electrical accessories such as the lights, climate control system, and rear defogger in order to reduce battery drain.

### ■ Starting the Ignition\*

Insert the key into the ignition and turn to turn on the vehicle or start the engine.

- 🔒 **LOCK:** Insert and remove the key in this position.
- 🔌 **ACCESSORY:** Operate the audio system and other accessories in this position.
- 🚗 **ON:** This is the position when driving.
- 🔑 **START:** This position is for starting the engine. The switch returns to ON when you release the key.

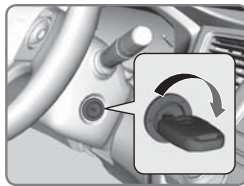

#### Manual transmission models

### ⚠️ WARNING

Removing the key from the ignition switch while driving locks the steering. This can cause you to lose control of the vehicle.

Remove the key from the ignition switch only when parked.

*\*if equipped*

### ■ Changing the Power Mode\*

Use the ENGINE START/STOP button to cycle through power modes or start the engine.

**Accessory or On mode:** Press ENGINE START/STOP once without pressing the brake pedal for Accessory mode. Press it again for On mode.

**Starting the engine:** Press and hold the brake pedal or clutch, then press ENGINE START/STOP. Keep your foot firmly on the brake pedal when starting the engine.

**Turning the vehicle off:** Shift to Park (P) or apply the parking brake, then press ENGINE START/STOP. If you press the button and the shift lever is not in Park (P), the vehicle goes into Accessory mode.



## Shifting

Change the shift position based on your driving needs.

### ■ Continuously Variable Transmission (CVT)\*

**Park (P):** Used for parking or starting/stopping the engine. Press the brake pedal, then press the release button to shift.

**Reverse (R):** Used for reversing.

**Neutral (N):** Used for idling.

**Drive (D):** Used for normal driving.

**Drive (S):** Used for better acceleration, increased engine braking, or driving in hilly terrain.

**Low (L):** Used for stronger engine power and braking when driving in hilly terrain.

#### Natural Gas (CNG) models

**Drive (D3):** Used for for driving in hilly terrain.

**Second (2):** Used for increased engine braking.

**First (1):** Used for stronger engine braking.



### NOTICE

When you change the shift lever from D to R and vice versa, come to a complete stop and keep the brake pedal depressed. Operating the shift lever before the vehicle has come to a complete standstill can damage the transmission.

Do not operate the shift lever while pressing the accelerator pedal. You could damage the transmission.

*\*if equipped*



**Paddle Shifters\***

Use the paddle shifters to change between 1st and 7th gears without removing your hands from the steering wheel.

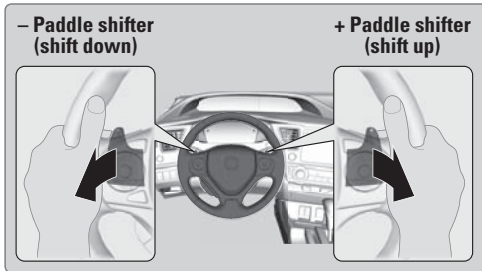

**Recommended shift points**

Shift up	Normal acceleration
1 to 2	15 mph (24 km/h)
2 to 3	25 mph (40 km/h)
3 to 4	40 mph (64 km/h)
4 to 5	45 mph (72 km/h)
5 to 6	50 mph (80 km/h)
6 to 7	55 mph (89 km/h)

**When the shift lever is in D:** The vehicle goes into manual shift mode temporarily, and the gear number appears. When you start traveling at a constant speed, manual shift mode automatically switches off, and the gear number goes off.

**When the shift lever is in S:** The vehicle goes into manual shift mode, and the M indicator and gear number come on. When the vehicle comes to a stop, it automatically shifts down into 1st gear. You can pull away only in 1st gear. If the vehicle speed increases and the engine speed approaches the tachometer's red zone, the transmission automatically shifts up.

To cancel manual shift mode, move the shift lever from S to D. The M indicator and gear number go off.

**Manual Transmission\***

Fully press the clutch pedal to operate the shift lever and change gears.

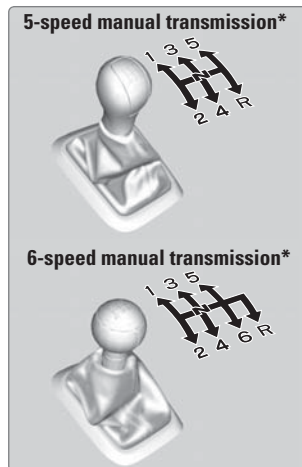

**Recommended shift points**

Shift Up	Normal Acceleration
1 to 2	15 mph (24 km/h)
2 to 3	27 mph (43 km/h)
3 to 4	39 mph (63 km/h)
4 to 5	53 mph (85 km/h)

**Recommended shift points**

Shift Up	Normal Acceleration
1 to 2	17 mph (27 km/h)
2 to 3	29 mph (46 km/h)
3 to 4	37 mph (59 km/h)
4 to 5	43 mph (69 km/h)
5 to 6	49 mph (79 km/h)

\*if equipped

**NOTICE**

Do not shift to Reverse (R) before the vehicle comes to a complete stop. This can damage the transmission.

**NOTICE**

Before downshifting, make sure the engine will not go into the tachometer's red zone. This can severely damage your engine.

**Braking**

Slow down or stop your vehicle, and keep it from moving when parked.

**Foot Brake**

Press the brake pedal to slow down or stop your vehicle from moving.

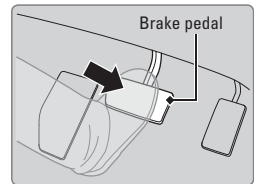

**Brake Assist System**

During hard or emergency braking, the system increases braking force. The brake pedal may move slightly or make a noise; this is normal. Continue to hold the brake pedal firmly down.

**Anti-Lock Brake System (ABS)**

During hard or emergency braking, the system rapidly pumps the brakes to prevent wheel lockup and help you maintain steering control. The brake pedal may pulsate slightly during ABS operation; this is normal. Do not pump the brake pedal, and continue to hold it firmly down.

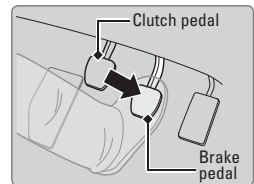

**NOTICE**

The ABS may not function correctly if you use an incorrect tire type and size.

**Parking Brake**

Keep the vehicle from moving when it is parked.

**To apply:** Pull the lever up fully without pressing the release button.

**To release:** Press and hold the release button, then lower the lever down all the way.



**NOTICE**

Release the parking brake fully before driving. The rear brakes and axle can be damaged if you drive with the parking brake applied.

### Eco Assist System\*

Can help improve fuel economy by adjusting the performance of the engine, transmission, climate control system, and cruise control.

#### ECON Button

Press the ECON button to turn the system on or off. The ECON Mode indicator appears when the system is turned on.

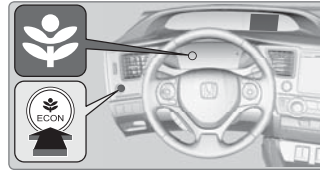

#### Ambient Meter

Color-coded bars change based on your driving style and brake or accelerator pedal operation.

**Green:** Fuel efficient driving

**Blue-green:** Moderate acceleration/deceleration

**Blue:** Aggressive acceleration/deceleration

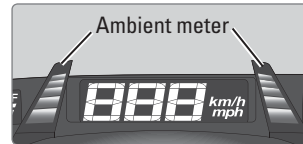

### Vehicle Stability Assist (VSA®), aka Electronic Stability Control (ESC) System

Helps to stabilize the vehicle during cornering if the vehicle turns more or less than what was intended. It assists in maintaining traction on slippery surfaces by regulating engine output and selectively applying the brakes.

#### Turning VSA On or Off

VSA is turned on every time you start the engine, even if you previously turned it off. If you turn VSA off, your vehicle has normal braking and cornering ability, but not VSA traction and stability enhancement.

Press and hold the VSA OFF button until you hear a beep to turn VSA on or off. The VSA OFF indicator appears when the system is off.

Traction control stops functioning, which may make it easier when trying to free your vehicle if it is stuck in mud or snow.

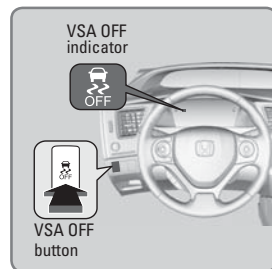

*\*if equipped*

### Cruise Control\*

Maintain a constant vehicle speed without having to keep your foot on the accelerator pedal. Use cruise control on freeways or open roads where you can travel at a constant speed with little acceleration or deceleration.

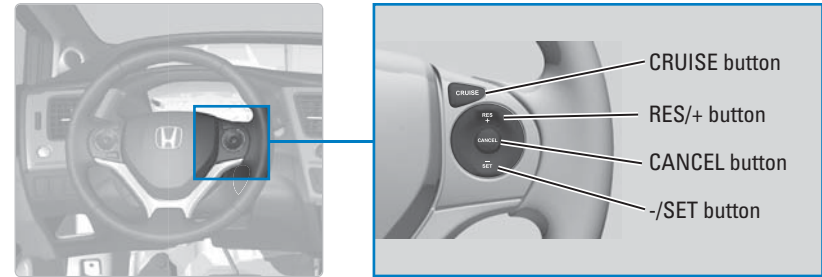

#### Activating and Setting the Vehicle Speed

1. Press CRUISE. The CRUISE MAIN indicator appears.
2. Accelerate to the desired speed (above 25 mph/40 km/h). Press -/SET and take your foot off the pedal to set the speed. The CRUISE CONTROL indicator appears.



#### Adjusting the Vehicle Speed

Press RES/+ to increase or -/SET to decrease.

Each time you press the button, the vehicle speed is increased or decreased by about 1 mph (1.6 km/h). If you keep the button pressed, the vehicle speed increases or decreases until you release it.



#### Canceling Cruise Control

Press CANCEL or the brake pedal. The CRUISE CONTROL indicator goes off.

After cruise control has been canceled, you can still resume the prior set speed by pressing RES/+ while driving at a speed of at least 25 mph (40 km/h).

Press CRUISE to turn the system off.



### WARNING

Improper use of the cruise control can lead to a crash.  
Use cruise control only when traveling on open highways in good weather.

*\*if equipped*

### LaneWatch™\*

Check the passenger-side rear areas in the upper display when the right turn signal is activated.

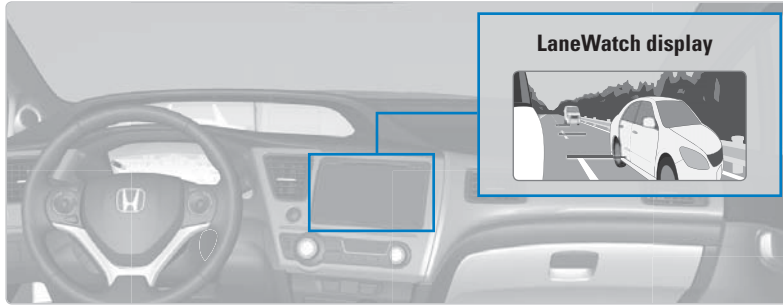

#### ■ Activating LaneWatch

Activate the right turn signal. The LaneWatch display appears. Check the display for blind spots, and visually confirm that it is safe to change lanes.

You can also press the LaneWatch button on the end of the turn signal switch to view a constant real-time display. Press it again to turn the display off.

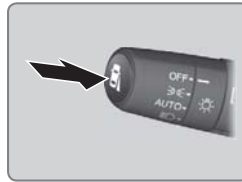

#### ■ Changing Settings

Customize the display and how and when the display appears.

1. From the Home screen, select Settings.
2. Select Camera.
3. Select LaneWatch.
4. Select an option and make the preferred changes.
5. Press BACK to exit the menu.



#### Important Safety Reminder

Like all assistance systems, LaneWatch has limitations. Over-reliance on the system may result in a collision.

### ⚠ WARNING

Failure to visually confirm that it is safe to change lanes before doing so may result in a crash and serious injury or death.

Do not rely only on LaneWatch while driving. Always look in your mirrors, to either side of your vehicle, and behind you for other vehicles before changing lanes.

\*if equipped

### Rearview Camera\*

When you shift into Reverse (R), a real-time image of the area behind your vehicle is shown in the i-MID or touchscreen\*, along with helpful parking guidelines.

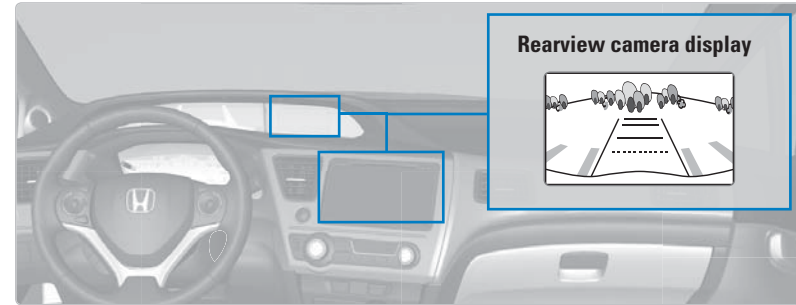

#### Models with touchscreen

#### ■ Changing Camera Settings

Turn the guidelines on or off.

1. From the Home screen, select Settings.
2. Select Camera.
3. Select Rear Camera.
4. Select an option:  
*Fixed Guidelines:* Guidelines appear when you shift into Reverse.  
*Dynamic Guidelines:* Guidelines move as you turn the steering wheel.
5. Select On or Off.
6. Press BACK to exit the menu.

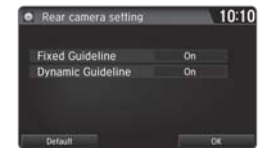

*The rear camera view is restricted. You cannot see the corner ends of the bumper or what is underneath the bumper. Its unique lens also makes objects appear closer or farther than they actually are.*

*Visually confirm that it is safe to drive before backing up. Certain conditions (such as weather, lighting, and high temperatures) may also restrict the rear view. Do not rely on the rearview display, which does not give you all information about conditions at the rear of your vehicle.*

\*if equipped

## Multi-View Rear Camera\*

When you shift into Reverse (R), a real-time image of the area behind your vehicle is shown in the display, along with helpful parking guidelines.

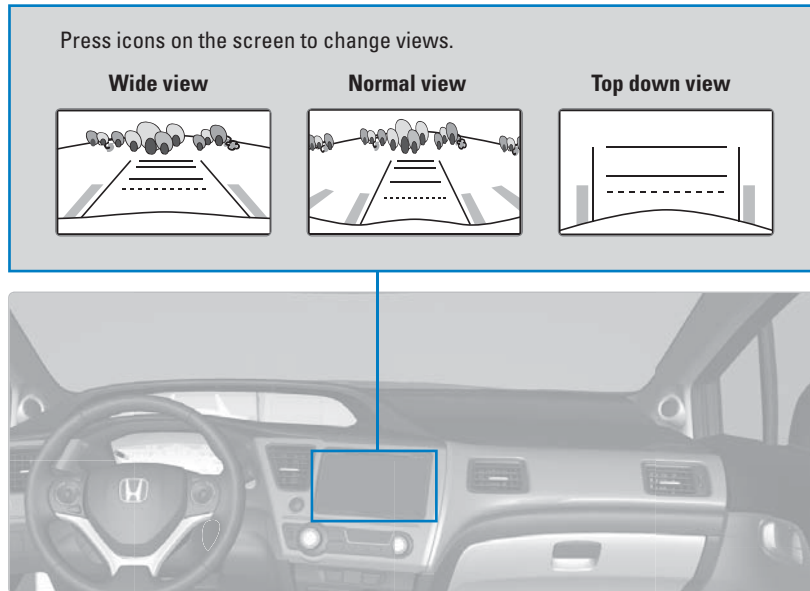

### Changing Camera Settings

Turn the guidelines on or off.

1. From the Home screen, select Settings.
2. Select Camera.
3. Select an option:
  - Fixed Guidelines:* Guidelines appear when you shift into Reverse.
  - Dynamic Guidelines:* Guidelines move as you turn the steering wheel.
4. Select On or Off.
5. Press BACK to exit the menu.



*The rear camera view is restricted. You cannot see the corner ends of the bumper or what is underneath the bumper. Its unique lens also makes objects appear closer or farther than they actually are.*

*Visually confirm that it is safe to drive before backing up. Certain conditions (such as weather, lighting, and high temperatures) may also restrict the rear view. Do not rely on the rearview display, which does not give you all information about conditions at the rear of your vehicle.*

\*if equipped

## Refueling

Use the proper fuel and refueling procedure to ensure the best performance and safety of your vehicle.

Sedan, Coupe, and Si models

### Fuel Information

**Use of unleaded gasoline of 87 octane or higher is recommended.**

**For Civic Si models, 91 octane or higher is recommended.**

- Honda recommends TOP TIER Detergent Gasoline where available.
- Do NOT use gasoline containing more than 15% ethanol.
- Do NOT use gasoline containing methanol.
- Do NOT use gasoline containing MMT.

### NOTICE

We recommend quality gasoline containing detergent additives that help prevent fuel system and engine deposits. In addition, in order to maintain good performance, fuel economy, and emissions control, we strongly recommend the use of gasoline that does NOT contain harmful manganese-based fuel additives such as MMT, if such gasoline is available.

### How to Refuel

1. The fuel fill door is located at the left rear of the vehicle. Park next to the service pump that is most accessible.
2. Turn off the engine.
3. Push the fuel fill door release handle near the bottom of the driver's seat. The fuel fill door opens.
4. Turn the fuel fill cap slowly to open. Place the fuel fill cap in the holder.
5. Insert the filler nozzle fully. When the tank is full, the fuel nozzle clicks off automatically.
6. Replace the fuel fill cap. Tighten it until you hear at least one click. Close the fuel fill door.

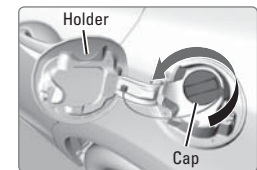
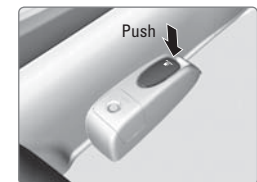

### WARNING

Gasoline is highly flammable and explosive. You can be burned or seriously injured when handling fuel.

- Stop the engine, and keep heat, sparks, and flame away.
- Handle fuel only outdoors.
- Wipe up spills immediately.

## Natural Gas (CNG) models

### Fuel Information

**Compressed natural gas that meets NFPA-52 and SAE J1616 standards is required.**

#### Slow filling

- 6.96 gasoline gallon equivalent (3,000 psi)
- 7.77 gasoline gallon equivalent (3,600 psi)

#### Fast filling

- 5.84 gasoline gallon equivalent (3,000 psi)
- 6.51 gasoline gallon equivalent (3,600 psi)

Your vehicle runs on compressed natural gas (CNG). The CNG in your vehicle is stored under high pressure. The system is designed to hold gas at the maximum of 3,600 psi/24,800 kPa, and you should never smell gas or hear a hissing sound unless you are refueling. If you smell gas or hear a hissing sound at any other time, shut down the CNG system immediately.

Your vehicle's fuel tank meets the safety standards of NGV-2/NFPA-52/DOT NHTSA FMVSS 304.

To ensure that your Civic Natural Gas vehicle receives CNG fuel with quality equal to or above the NFPA-52 and SAE J1616 fuel standards, Honda only recommends that your vehicle be refueled at a public commercial-grade CNG refueling station. Public stations offer an approximately five minute refueling time, and the assurance of natural gas quality meeting NFPA and SAE standards.

For information on the locations of the CNG fuel stations, visit either [www.afdc.energy.gov/afdc/fuels/natural\\_gas\\_locations.html](http://www.afdc.energy.gov/afdc/fuels/natural_gas_locations.html) or [www.cngprices.com](http://www.cngprices.com), or call NGVAmerica at (202) 824-7360. In California, visit [www.cngvc.org](http://www.cngvc.org).

The location of the CNG pump can vary from station to station, may not be clearly marked, or be readily accessible during certain hours. It is recommended that you call the station (the number should be displayed with the address information) to verify the location and availability of the CNG pump before you arrive.

Have an authorized dealer or certified NGV technician inspect the fuel tank every three years, or 36,000 miles, whichever comes first, and replace it 15 years from its production date. Do not use an expired tank or reuse the old tank for other purposes. After a collision, have the fuel tank inspected by an authorized dealer or certified NGV technician.

### **⚠️ WARNING**

Compressed natural gas is highly flammable and explosive. You can be burned or seriously injured if leaking natural gas is ignited.

If you suspect a leak, have your vehicle immediately inspected and repaired by an authorized Honda Civic Natural Gas dealer.

### How to Refuel

#### Slow filling

It takes about an hour and a half per GGE (Gasoline Gallon Equivalent) to fill up the fuel tank. This method can be done using a vehicle refueling appliance.

#### Fast filling

It takes about 3–5 minutes to fill up the fuel tank. This method is usually available at stations designed to refuel natural gas vehicles. During fast filling, the natural gas is warmed, causing the pressure in the tank to rise and reduces the amount of fuel you can put in. The steps for fast filling are described below.

1. The fuel fill door is located at the left rear of the vehicle. Park next to the service pump that is most accessible.
2. Turn off the engine.
3. Push the fuel fill door release handle near the bottom of the driver's seat. The fuel fill door opens.
4. Remove the receptacle dust cap from the fuel receptacle.
5. Securely connect the CNG fill nozzle to the fuel receptacle.
6. Turn the lever until the arrows on the nozzle point to each other, then follow the instructions on the refueling station to begin refueling. You may hear a chattering sound; this is normal. **If you hear or see fuel/vapor leaking from the nozzle-receptacle connection, stop refueling immediately.**
7. Refueling will stop automatically when the tank is full. Follow the instructions on the refueling station to turn it off.
8. Disconnect the CNG fill nozzle from the fuel receptacle by slowly turning the lever on the nozzle 180 degrees. You may hear a brief hissing sound as a small amount of gas escapes, and may detect a slight gas odor. This is normal.
9. After filling, replace the receptacle dust cap on the fuel receptacle securely. Close the fuel lid door.

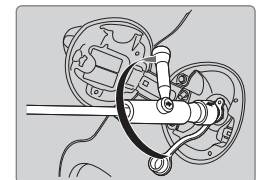
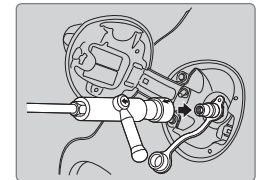
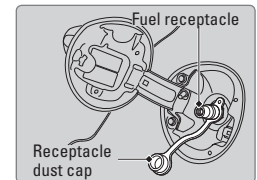
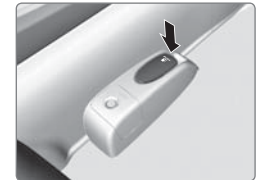

### **NOTICE**

Using fast fill equipment at temperature below -4°F (-20°C) may damage the fuel system, potentially causing a leak.



### ■ If a Fuel Leak Is Detected

If you smell natural gas or hear a hissing sound (except when refueling), the fuel system may have a leak. Turn off the manual shut-off valve immediately. You should locate the valve before driving in case you need to turn it off quickly.

1. Park your vehicle outside in a well-ventilated area, away from heat, sparks, and flame. Apply the parking brake. Turn off the vehicle.
2. Open all windows and the trunk for proper ventilation.
3. Turn the manual shut-off valve one-quarter turn clockwise (as shown). The valve is turned to OFF.
4. Call a professional towing service (see page 106). Do not continue driving. Have the vehicle towed to an authorized Civic Natural Gas dealer.

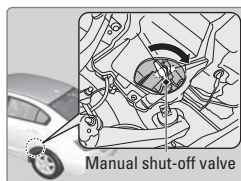

## HANDLING THE UNEXPECTED

Learn about what to do in critical or emergency situations.

### Smart Entry Remote Battery Strength

If the battery life in your remote transmitter is weak, a message appears in the display with information on how to start the engine.

1. Touch the back of the remote transmitter to the ENGINE START/STOP button while the indicator is flashing.
2. With the brake pedal or clutch pedal pressed, press the ENGINE START/STOP button within 10 seconds.

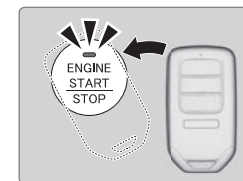

### Jump Starting

Turn off the power to electric devices, such as audio and lights. Turn off the engine, then open the hood.

1. Connect the first jumper cable to your vehicle's battery (+) terminal.
2. Connect the other end of the first jumper cable to the booster battery (+) terminal. Use a 12-volt booster battery only.
3. Connect the second jumper cable to the booster battery (-) terminal.
4. Connect the other end of the second jumper cable to the grounding point as shown. Do not connect this jumper cable to any other part.
5. If your vehicle is connected to another vehicle, start the assisting vehicle's engine and increase its rpm slightly.
6. Attempt to start your vehicle's engine. If it turns over slowly, make sure that the jumper cables have good metal-to-metal contact.

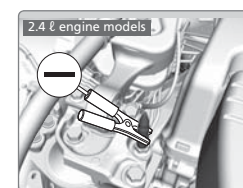
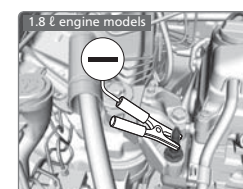
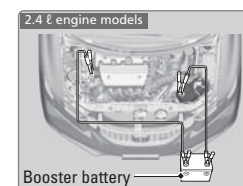
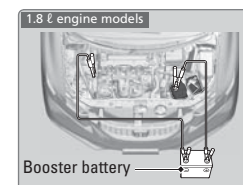

**WARNING:** Battery posts, terminals, and related accessories contain lead and lead compounds. **Wash your hands after handling.**

### **⚠ WARNING**

A battery can explode if you do not follow the correct procedure, seriously injuring anyone nearby.  
Keep all sparks, open flames, and smoking materials away from the battery.

#### ■ After the Engine Starts

Once your vehicle's engine has started, remove the jumper cables in the following order:

1. Disconnect the jumper cable from your engine hanger.
2. Disconnect the other end of the jumper cable from the assisting vehicle's (-) terminal.
3. Disconnect the jumper cable from your vehicle's (+) terminal.
4. Disconnect the other end of the jumper cable from the assisting vehicle's (+) terminal.
5. Have your vehicle inspected by a nearby service station or a dealer.

#### Shift Lever Does Not Move\*

Follow the procedure below if you cannot move the shift lever out of Park (P).

1. Set the parking brake.
2. Remove the key from the ignition, or remove the built-in key from the remote transmitter.
3. Wrap a cloth around the tip of a small flat-tip screwdriver to remove the cover of the shift lock release slot. Put the tip of the flat-tip screwdriver into the slot and remove it as shown in the image.
4. Insert the key into the shift lock release slot.
5. While pushing the key down, press the shift lever release button and place the shift lever into Neutral (N). The lock is now released. Have the shift lever checked by a dealer as soon as possible.

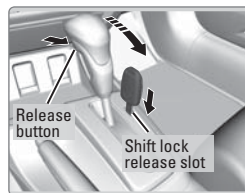

#### Overheating

If the temperature gauge needle is at the H mark, the engine suddenly loses power, or steam or spray comes out from under the hood, your engine is overheating.

1. Immediately park the vehicle in a safe place. Turn off all accessories and turn on the hazard warning lights.
2. *If steam or spray is not present:* Keep the engine running and open the hood.

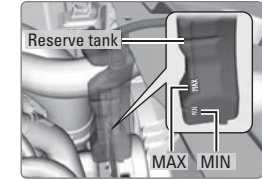

*If steam or spray is present:* Turn off the engine and wait until it subsides. Then, open the hood.

3. Check that the cooling fan is operating and stop the engine once the temperature gauge needle comes down. If the cooling fan is not operating, immediately stop the engine.
4. Once the engine has cooled down, inspect the coolant level and check the cooling system components for leaks. If the coolant level in the reserve tank is low, add coolant until it reaches the MAX mark. If there is no coolant in the reserve tank, make sure the radiator is cool, then cover the radiator cap with a heavy cloth and open the cap. If necessary, add coolant up to the base of the filler neck, and put the cap back on.

Once the engine has cooled sufficiently, restart it and check the temperature gauge. If the temperature needle has gone down, resume driving. If it has not gone down, contact a dealer for repairs.

### **⚠ WARNING**

Steam and spray from an overheated engine can seriously scald you.  
Do not open the hood if steam is coming out.

### **⚠ WARNING**

Removing the radiator cap while the engine is hot can cause the coolant to spray out, seriously scalding you.  
Always let the engine and radiator cool down before removing the radiator cap.

### **NOTICE**

Continuing to drive with the temperature gauge needle at the H mark may damage the engine.

\*if equipped



### Emergency Engine Stop\*

The ENGINE START/STOP button may be used to stop the engine due to an emergency situation even while driving. If you must stop the engine, choose one of the following operations:

- Press and hold the ENGINE START/STOP button for two seconds, or
- Firmly press the ENGINE START/STOP button two times.



The steering wheel will not lock. The power mode changes to ACCESSORY, unless the shift lever is in Park (P), in which case the power mode changes to VEHICLE OFF. Because turning off the engine also disables the power assist the engine provides to the steering and braking systems, it will require significantly more physical effort and time to steer and slow the vehicle. Downshift gears and use both feet on the brake pedal, if necessary, to slow the vehicle and stop immediately in a safe place.

Do not press the button while driving unless it is absolutely necessary for the engine to be switched off.

### Emergency Towing

Call a professional towing service if you need to tow your vehicle.

Flat bed equipment: The operator loads your vehicle on the back of a truck. **This is the best way to transport your vehicle.**

Wheel lift equipment: The tow truck uses two pivoting arms that go under the front tires and lift them off the ground. The rear tires remain on the ground. **This is an acceptable way to tow your vehicle.**

#### NOTICE

Trying to lift or tow your vehicle by the bumpers will cause serious damage. The bumpers are not designed to support the vehicle's weight.

Improper towing such as towing behind a motorhome or other motor vehicle can damage the transmission.

*\*if equipped*

### Tire Pressure Monitoring System (TPMS)\*

Monitors the tire pressure while you are driving. If your vehicle's tire pressure becomes significantly low, the low tire pressure indicator comes on and a message appears on the display.



#### ■ What to Do

Stop your vehicle in a safe place. Check the tire pressure and adjust the pressure to the specified level on the label on the driver's doorjamb.

#### ■ TPMS Calibration

Any time you inflate, change, or rotate one or more of the tires, you need to recalibrate the system. Use the buttons on the steering wheel to enter and operate the Vehicle Menu (see page 43).

1. Press MENU.
2. Select Customize Settings.
3. Select TPMS Calibration.
4. Select Initialize.
5. Select Yes.
6. Press MENU to exit.

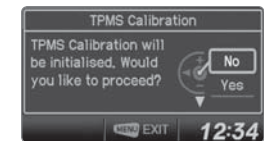
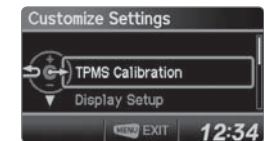

#### NOTICE

Driving on an extremely underinflated tire can cause it to overheat. An overheated tire can fail. Always inflate your tires to the specified pressure.

*\*if equipped*

## Changing a Flat Tire

If a tire goes flat while driving, grasp the steering wheel firmly, and brake gradually to reduce speed. Then, stop in a safe place. Replace the flat tire with the compact spare tire\*. Go to a dealer as soon as possible to have the full-size tire repaired or replaced.

### Getting Ready to Change the Tire

Park the vehicle on a firm, level, non-slippery surface. Apply the parking brake, shift to Park (P), and turn the vehicle off. Turn on the hazard warning lights.

1. Open the trunk floor lid.

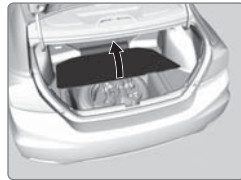

2. Take the tool case out of the trunk. Take the jack and wheel nut wrench out of the tool case.

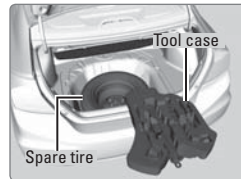

3. Unscrew the wing bolt, then remove the spacer cone. Remove the spare tire.

4. Place the compact spare tire (wheel side up) under the vehicle body, near the tire that needs to be replaced. If necessary, remove the center cap from the wheel with the jack handle bar.



5. Loosen each wheel nut about one turn using the wheel nut wrench.



### Setting Up the Jack

1. Place the jack under the jacking point closest to the tire to be changed.

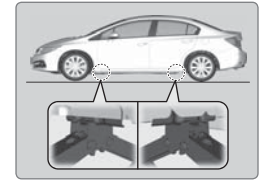

2. Turn the end bracket clockwise (as shown in the image) until the top of the jack contacts the jacking point. Make sure that the jacking point tab is resting in the jack notch.



3. Raise the vehicle, using the jack handle bar and the jack handle, until the tire is off the ground.

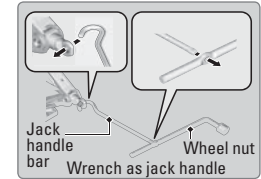

### WARNING

The vehicle can easily roll off the jack, seriously injuring anyone underneath. Follow the directions for changing a tire exactly, and never get under the vehicle when it is supported only by the jack.

The following instructions must be followed to use the jack safely:

- Do not use the jack with people or luggage in the vehicle.
- Use the jack provided in your vehicle. Other jacks may not support the weight ("load") or fit the jacking point.
- Do not use while the engine is running.
- Use only where the ground is firm and level.
- Use only at the jacking points.
- Do not get in the vehicle while using the jack.
- Do not put anything on top of or underneath the jack.

\*if equipped

**■ Replacing the Flat Tire**

1. Remove the wheel nuts, wheel cover (if necessary), and flat tire.
2. Mount the compact spare tire. Replace the wheel nuts, and lightly tighten them.
3. Lower the vehicle and remove the jack. Tighten the wheel nuts in the order indicated in the image. Go around, tightening the nuts, two to three times in this order. Do not overtighten the wheel nuts.

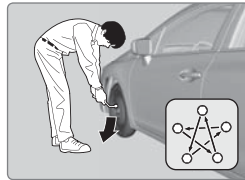
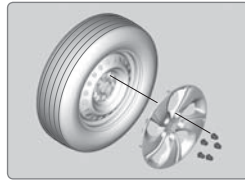

If you drive with the spare tire installed, the low tire pressure/TPMS indicator appears. The indicator stays on until a regular tire is installed.

**NOTICE**

Civic Si models: Do not mount the compact spare tire on the front, as it may damage the differential. If a front tire goes flat, replace it with the rear tire from the same side, and mount the compact spare tire in the rear.

**■ Storing the Flat Tire**

1. Remove the center cap, if necessary.
2. Open the trunk. Place the flat tire face down in the spare tire well.
3. Remove the spacer cone from the wing bolt, flip it over, and insert it back on the bolt. Secure the flat tire with the wing bolt.
4. Securely put the jack and wheel nut wrench back in the tool case. Store the case in the trunk.

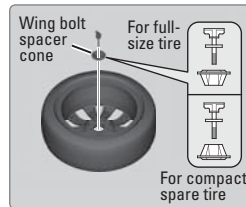
**⚠ WARNING**

Loose items can fly around the interior in a crash and can seriously injure the occupants.

Store the wheel, jack, and tools securely before driving.

**Tire Repair Kit\***

If a tire has a small puncture, you can use the tire repair kit to temporarily repair it. The puncture must be smaller than 3/16-inch (4 mm) and not in the tire sidewall. Go to a dealer to have the full-size tire permanently repaired or replaced.

**■ Before Repairing the Tire**

1. Park the vehicle on a firm, level, non-slippery surface.
2. Move the shift lever to Park (P), and apply the parking brake.
3. Turn on the hazard warning lights, and turn off the vehicle.

**■ Getting Ready to Repair the Tire**

1. Open the trunk floor lid.
2. Remove the kit from the case.
3. Place the kit face up on flat ground near the punctured tire and away from traffic. Do not place the kit on its side.
4. Follow the instructions in the kit to repair the tire.

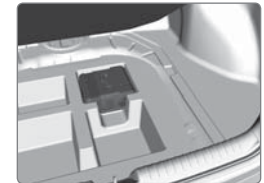
**NOTICE**

Do not use a puncture-repairing agent other than the one provided in the kit that came with your vehicle. If a different agent is used, you may permanently damage the tire pressure sensor.

Do not operate the temporary tire repair kit compressor for more than 15 minutes. The accessory power socket and compressor can overheat and become permanently damaged.

**⚠ WARNING**

Running the engine with the vehicle in an enclosed or even partly enclosed area can cause a rapid build-up of toxic carbon monoxide.

Breathing this colorless, odorless gas can cause unconsciousness and even death. Only run the engine to power the air compressor with the vehicle outdoors.

### Fuse Locations

If any electrical devices are not working, turn the vehicle off and check to see if any applicable fuse is blown. Fuse locations are shown on the fuse box cover. Locate the fuse in question by the fuse number and box cover number.

#### Engine Compartment Fuse Box

Located under the hood near the brake fluid reservoir. Push the tabs to open the box.

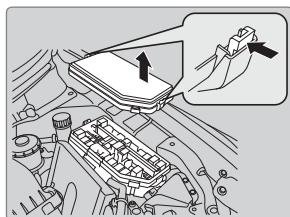

	Circuit Protected	Amps
1	EPS	70 A
	-	(40 A)
	ABS/VSA Motor	30 A
	ABS/VSA FSR	30 A
	Wiper Motor <sup>1</sup>	30 A
	- <sup>2</sup>	(30 A)
	Main Fuse	100 A
	IG Main	30 A <sup>2</sup>
	-	50 A <sup>3</sup>
	Fuse Box Main	60 A
2	Fuse Box Main 2	60 A
	Headlight Main	30 A
	ST MG Switch <sup>1</sup>	30 A
	- <sup>2</sup>	(30 A)
	Rear Defogger	30 A
	IG Main 2 <sup>1</sup>	30 A
	- <sup>2</sup>	(30 A)
	Blower	40 A
	-	(30 A)
	Sub Fan Motor	20 A
Main Fan Motor	20 A	
3	-	-
	- <sup>1</sup>	-
4	Left Headlight Low Beam <sup>2</sup>	15 A
	START DIAG <sup>1</sup>	7.5 A
5	ST MG <sup>2</sup>	7.5 A
	- <sup>1</sup>	-
6	Right Headlight Low Beam <sup>2</sup>	15 A
	-	-
7	-	-
	-	-
8	-	-
	-	-

	Circuit Protected	Amps
9	-	-
	-	-
11	Oil Level	7.5 A
	Fog Lights <sup>*</sup>	(20 A)
13	Driver's Power Seat Sliding <sup>*</sup>	(20 A)
	Hazard	10A
15	FI Sub	15A
	IG Coil	15A
17	Stop	15A
	Horn	10A
19	Premium Amp <sup>*</sup>	(20A)
	Right Headlight Low Beam <sup>1</sup>	15 A
20	Injection <sup>*,2</sup>	(15A)
	IGP	15A
22	DBW	15A
	Left Headlight Low Beam <sup>1</sup>	15A
23	Headlight Low Beam <sup>2</sup>	20 A
	Driver's Power Seat Reclining <sup>*</sup>	(20 A)
25	MG Clutch	7.5A
	Washer <sup>1</sup>	15 A
26	- <sup>2</sup>	-
	SMALL	20A
28	Interior Lights	7.5 A
	Backup	10A

\*1: Models with smart entry system  
\*2: Models without smart entry system

#### Interior Fuse Box

Located under the dashboard on the driver's side.

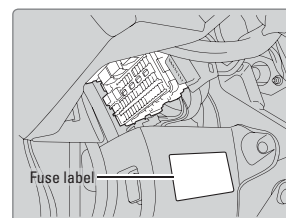

	Circuit Protected	Amps
1	HAC Option <sup>*</sup>	(20 A)
	ACG	10A
3	SRS	10A
	Fuel Pump	15A
5	Meter	7.5A
	Power Window	7.5A
7	VB SOL <sup>*</sup>	(15A)
	Door Lock Motor 2 (Unlock)	15A
9	Door Lock Motor 1 (Unlock)	15A
	-	-
11	Moonroof <sup>*</sup>	(20A)
	Accessory Power Socket (Center Console) <sup>*</sup>	(20A)
13	-	-
	Seat Heaters <sup>*</sup>	(15A)
15	Driver's Door Lock Motor (Unlock) <sup>*</sup>	(10 A)
	-	-
17	-	-
	-	-
19	ACC	7.5A
	ACC Key Lock	7.5A
21	Daytime Running Lights	7.5 A
	HAC	7.5A

	Circuit Protected	Amps
23	HAC <sup>*</sup>	(7.5 A)
	ABS/VSA	7.5A
25	ACC <sup>*</sup>	(7.5 A)
	-	-
27	Accessory Power Socket (Front)	20A
	Washer	(15A)
29	ODS	7.5A
	Driver's Door Lock Motor (Lock) <sup>*</sup>	(10A)
31	SMART <sup>*</sup>	(10A)
	Door Lock Motor 2 (Lock)	15A
33	Door Lock Motor 1 (Lock)	15 A
	Small Lights	7.5 A
35	Illumination	7.5 A
	-	-
37	-	-
	Left Headlight High Beam	10 A
39	Right Headlight High Beam	10 A
	TPMS <sup>*</sup>	(7.5 A)
41	Door Lock	20 A
	Driver's Power Window	20 A
43	Rear Passenger's Side Power Window	(20 A)
	Front Passenger's Side Power Window	20 A
45	Rear Driver's Side Power Window	(20 A)
	Wiper	(30A)
-	STS <sup>*</sup>	(7.5A)

\*if equipped

\*if equipped

### ■ Inspecting and Changing Fuses

1. Turn the vehicle off, including all lights and accessories.
2. Remove the fuse box cover.

3. Check the large fuse in the engine compartment.

If the fuse is blown, use a Phillips-head screwdriver to remove the screws and replace the fuse with a new one. Reinstall the screws.

4. Inspect the small fuses in the engine compartment and the vehicle interior.

If there is a burned out fuse, remove it with the fuse puller and replace it with a new one.

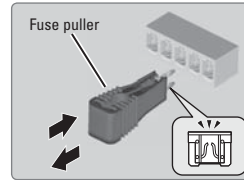
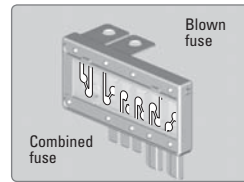

#### NOTICE

Replacing a fuse with one that has a higher rating greatly increases the chances of damaging the electrical system.

## MAINTENANCE

Learn about basic maintenance that you can perform on the vehicle yourself, as well as information about how to best maintain the vehicle.

### Safety Precautions

Some of the most important safety precautions are listed below; however, we cannot warn you of every conceivable hazard that can arise in performing maintenance. Only you can decide whether or not you should perform a given task.

#### ■ Maintenance Safety

- To reduce the possibility of fire or explosion, keep cigarettes, sparks, and flames away from the battery and all fuel-related parts.
- Never leave rags, towels, or other flammable objects under the hood.
- To clean parts, use a commercially available degreaser or parts cleaner, not gasoline.
- Wear eye protection and protective clothing when working with the battery or compressed air.
- Do not run the engine in confined spaces where carbon monoxide gas can accumulate.

#### ■ Vehicle Safety

- The vehicle must be stationary, and parked on level ground with the parking brake set and the engine off.
- Be aware that hot parts can burn you.
- Be aware that moving parts can injure you.

#### ⚠ WARNING

Improperly maintaining this vehicle or failing to correct a problem before driving can cause a crash in which you can be seriously hurt or killed.

Always follow the inspection and maintenance recommendations according to the schedules in this guide.

#### ⚠ WARNING

Failure to properly follow maintenance instructions and precautions can cause you to be seriously hurt or killed.

Always follow the procedures and precautions in this guide.

### Maintenance Minder™

Reminds you when indicated maintenance service is due.

#### Models with information display

When maintenance is due, the Maintenance Minder indicator comes on and a message appears on the display every time you turn the vehicle on. Press the select/reset knob to change displays.

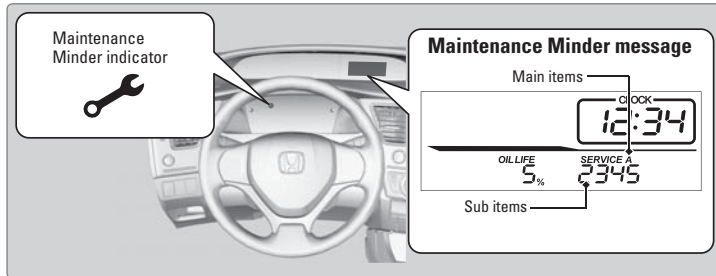

#### Models with i-MID

When maintenance is due, the system message indicator comes on and a message appears on the display every time you turn the vehicle on. Press the Info button on the steering wheel to change displays.

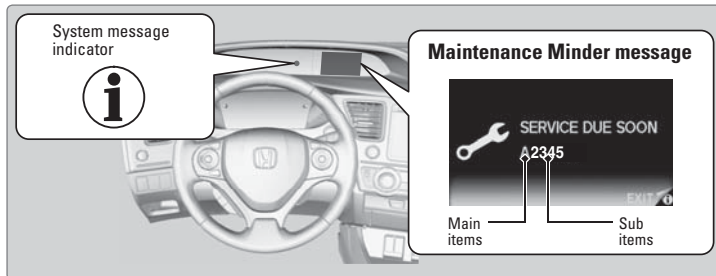

- Independent of the Maintenance Minder information, replace the brake fluid every 3 years.
- Inspect idle speed every 160,000 miles (256,000 km).
- Adjust the valves during services A, B, 1, 2, or 3 if they are noisy.

### Maintenance Minder Service Codes

These codes indicate what services are due on your vehicle.

#### Sedan, Coupe, and Si models

CODE	Maintenance Main Items
A	<ul style="list-style-type: none"> <li>• Replace engine oil*1</li> </ul>
B	<ul style="list-style-type: none"> <li>• Replace engine oil*1 and oil filter</li> <li>• Inspect front and rear brakes/service as necessary</li> <li>• Check parking brake adjustment</li> <li>• Inspect tie rod ends, steering gearbox, and boots</li> <li>• Inspect suspension components</li> <li>• Inspect driveshaft boots</li> <li>• Inspect brake hoses and lines (Including ABS/VSA)</li> <li>• Inspect all fluid levels and condition of fluids</li> <li>• Inspect exhaust system#</li> <li>• Inspect fuel lines and connections#</li> <li>• Check the expiration date for TRK bottle*2</li> </ul>

\*1: If a message SERVICE does not appear more than 12 months after the display is reset, change the engine oil every year.

\*2: Models with tire repair kit

#: See information on maintenance and emissions warranty.

CODE	Maintenance Sub Items
1	<ul style="list-style-type: none"> <li>• Rotate tires</li> </ul>
2	<ul style="list-style-type: none"> <li>• Replace air cleaner element*2</li> <li>• Replace dust and pollen filter*3</li> <li>• Inspect drive belt</li> </ul>
3	<ul style="list-style-type: none"> <li>• Replace transmission fluid*4</li> </ul>
4	<ul style="list-style-type: none"> <li>• Replace spark plugs</li> <li>• Inspect valve clearance</li> </ul>
5	<ul style="list-style-type: none"> <li>• Replace engine coolant</li> </ul>

\*2: If you drive in dusty conditions, replace the air cleaner element every 15,000 miles (24,000 km).

\*3: If you drive primarily in urban areas that have high concentrations of soot in the air from industry and from diesel-powered vehicles, replace the dust and pollen filter every 15,000 miles (24,000 km).

\*4: **Continuously variable transmission (CVT) models**

Driving in mountainous areas at very low vehicle speeds or trailer towing results in higher transmission temperatures. This requires transmission fluid changes more frequently than recommended by the Maintenance Minder. If you regularly drive your vehicle under these conditions, have the transmission fluid changed every 25,000 miles (40,000 km).



Natural Gas (CNG) models

CODE	Maintenance Main Items
A	<ul style="list-style-type: none"> <li>• Replace engine oil <sup>*1</sup></li> </ul>
B	<ul style="list-style-type: none"> <li>• Replace engine oil <sup>*1</sup> and oil filter</li> <li>• Replace fuel filter element (low pressure)</li> <li>• Drain fuel filter (high pressure)</li> <li>• Inspect front and rear brakes/service as necessary</li> <li>• Check parking brake adjustment</li> <li>• Inspect tie rod ends, steering gearbox, and boots</li> <li>• Inspect suspension components</li> <li>• Inspect driveshaft boots</li> <li>• Inspect brake hoses and lines (Including ABS/VSA)</li> <li>• Inspect all fluid levels and condition of fluids</li> <li>• Inspect exhaust system <sup>#</sup></li> <li>• Inspect fuel lines and connections <sup>#</sup></li> <li>• Check the expiration date for TRK bottle</li> </ul>

<sup>\*1</sup>: If a message SERVICE does not appear more than 12 months after the display is reset, change the engine oil every year.

<sup>#</sup>: See information on maintenance and emissions warranty.

CODE	Maintenance Sub Items
1	<ul style="list-style-type: none"> <li>• Rotate tires</li> </ul>
2	<ul style="list-style-type: none"> <li>• Replace air cleaner element <sup>*2</sup></li> <li>• Replace dust and pollen filter <sup>*3</sup></li> <li>• Replace fuel filter element (high pressure)</li> <li>• Inspect drive belt</li> <li>• Inspect valve clearance</li> <li>• Inspect fuel tank <sup>*4</sup></li> </ul>
3	<ul style="list-style-type: none"> <li>• Replace transmission fluid</li> </ul>
4	<ul style="list-style-type: none"> <li>• Replace spark plugs</li> </ul>
5	<ul style="list-style-type: none"> <li>• Replace engine coolant</li> </ul>

<sup>\*2</sup>: If you drive in dusty conditions, replace the air cleaner element every 15,000 miles (24,000 km).

<sup>\*3</sup>: If you drive primarily in urban areas that have high concentrations of soot in the air from industry and from diesel-powered vehicles, replace the dust and pollen filter every 15,000 miles (24,000 km).

<sup>\*4</sup>: If sub item 2 does not appear more than 36 months after the display is reset, inspect the fuel tank every three years.

See CNG tank expiration and production dates for inspection and replacement information. Fuel tank should be replaced 15 years after it was manufactured.

U.S. models

**Maintenance, replacement, or repair of emissions control devices and systems may be done by any automotive repair establishment or individuals using parts that are certified to EPA standards.**

According to state and federal regulations, failure to perform maintenance on the maintenance main items marked with # will not void your emissions warranties. However, all maintenance services should be performed in accordance with the intervals indicated by the multi-information display.

Under the Hood

Sedan, Coupe, and Natural Gas (CNG) models

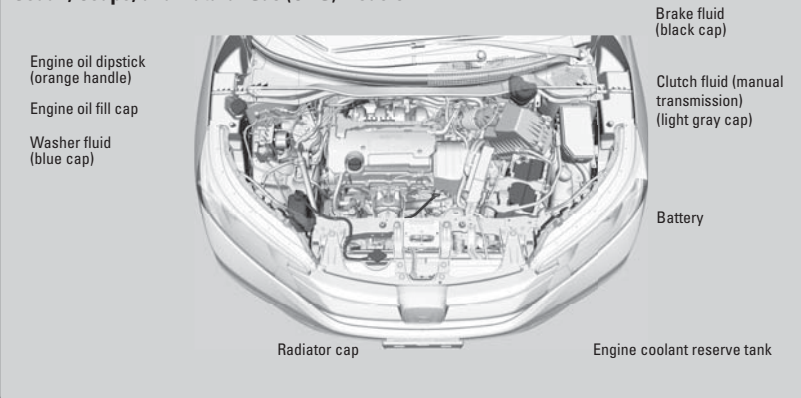

Si models

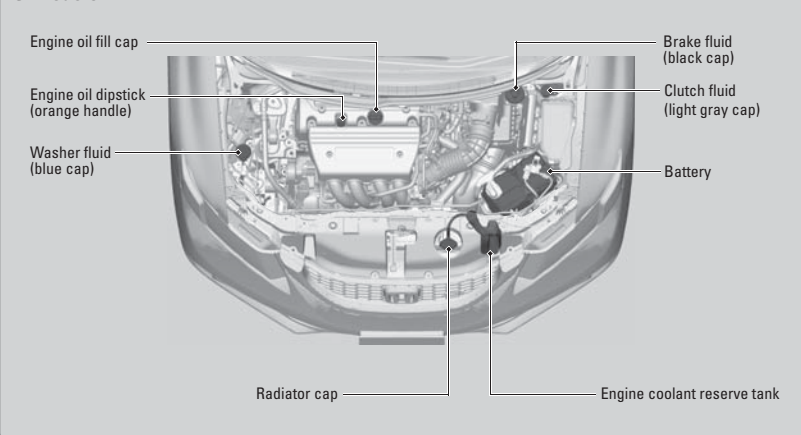

■ Opening the Hood

1. Park the vehicle on a level surface, and set the parking brake.
2. Pull the hood release handle under the lower left corner of the dashboard.
3. Push up the hood latch lever in the center of the hood to release the lock mechanism, and open the hood.
4. Remove the support rod from the clamp using the grip. Mount the support rod in the hood.

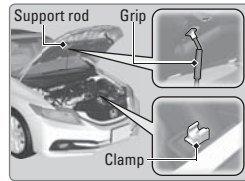

When closing, remove the support rod, and stow it in the clamp, then gently lower the hood. Remove your hand at a height of approximately 12 inches (30 cm) and let the hood close.

**NOTICE**

Do not open the hood when the wiper arms are raised. The hood will strike the wipers, and may damage either the hood or the wipers.

**Engine Oil**

Park the vehicle on level ground, and wait approximately three minutes after turning the engine off before you check the oil.

■ Checking the Oil

1. Remove the dipstick (orange handle).
2. Wipe the dipstick with a clean cloth or paper towel.
3. Insert the dipstick back all the way into its hole.

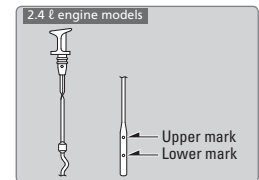
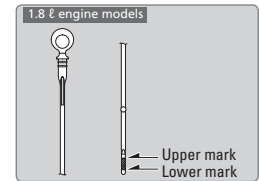
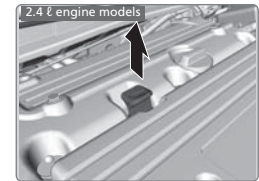
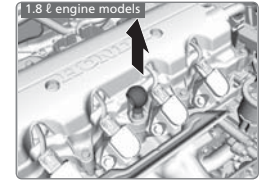

4. Remove the dipstick again, and check the level. It should be between the upper and lower marks. Add oil if necessary.

**Recommended Engine Oil**

- **Honda Genuine Motor Oil**
- **Premium-grade 0W-20 detergent oil with an API Certification Seal on the container**

This seal indicates the oil is energy conserving and that it meets the American Petroleum Institute's latest requirements.



Use Honda Genuine Motor Oil or another commercial engine oil of suitable viscosity for the ambient temperature as shown.

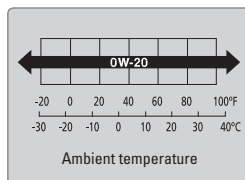

You may also use synthetic motor oil if it is labeled with the API Certification Seal and is of the specified viscosity grade.

**Adding Oil**

1. Unscrew and remove the engine oil fill cap.
2. Add oil slowly.
3. Reinstall the engine oil fill cap, and tighten it securely.
4. Wait for three minutes and recheck the engine oil dipstick.

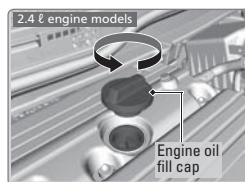
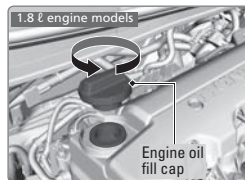

**NOTICE**

Do not fill the engine oil above the upper mark. Overfilling the engine oil can result in leaks and engine damage.

**Resetting the Engine Oil Life**

If you change or replace the vehicle's engine oil yourself, you must reset the engine oil life.

**Models with information display**

1. Press the select/reset knob until the engine oil life appears in the display.
2. Press and hold the knob for 10 seconds or more, until the display begins to blink.
3. Press and hold the knob for 5 seconds or more. The engine oil life display returns to 100%.

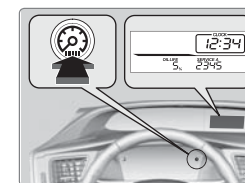

**Models with multi-information display**

Use the steering wheel buttons to control the display.

1. Press MENU to go to the Vehicle Menu screen.
2. Select Vehicle Information.
3. Select Maintenance Info. The engine oil life appears on the i-MID.
4. Select oil life reset mode.
5. Select Yes. The engine oil life display returns to 100%.

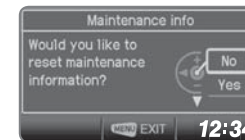
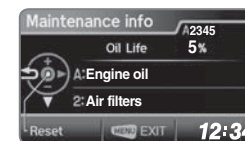

**NOTICE**

Failure to reset the engine oil life after a maintenance service results in the system showing incorrect maintenance intervals, which can lead to serious mechanical problems.

## Engine Coolant

Park the vehicle on level ground. Check the reserve tank and the coolant level in the radiator. **We recommend Honda Long Life Antifreeze/Coolant Type 2.**

### ■ Checking the Reserve Tank

1. Check the amount of coolant in the reserve tank.
2. If the coolant level is below the MIN mark, add the specified coolant until it reaches the MAX mark.
3. Inspect the cooling system for leaks.

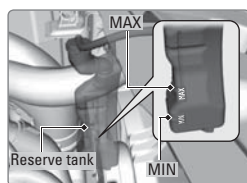

### NOTICE

If temperatures consistently below  $-22^{\circ}\text{F}$  ( $-30^{\circ}\text{C}$ ) are expected, the coolant mixture should be changed to a higher concentration. Consult a dealer for details for more information.

### ■ Adding Coolant

1. Make sure the engine and radiator are cool.
2. Turn the radiator cap counterclockwise and relieve any pressure in the coolant system. Do not push the cap down when turning.
3. Push down and turn the radiator cap counterclockwise to remove it.
4. The coolant level should be up to the base of the filler neck. Add coolant if it is low.
5. Put the radiator cap back on, and tighten it fully.
6. Pour coolant into the reserve tank until it reaches the MAX mark. Put the cap back on the reserve tank.

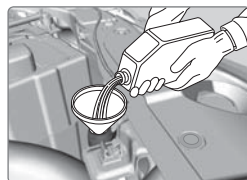
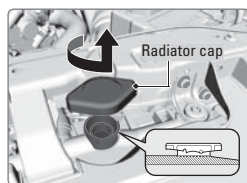

### ⚠ WARNING

Removing the radiator cap while the engine is hot can cause the coolant to spray out, seriously scalding you.

Always let the engine and radiator cool down before removing the radiator cap.

### NOTICE

Pour the fluid slowly and carefully so you do not spill any. Clean up any spills immediately; they can damage components in the engine compartment.

## Checking the Battery

Check the battery terminals for corrosion monthly.

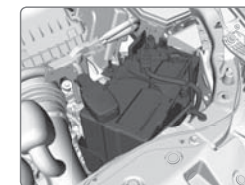

### ⚠ WARNING

The battery gives off explosive hydrogen gas during normal operation.

A spark or flame can cause the battery to explode with enough force to kill or seriously hurt you.

When conducting any battery maintenance, wear protective clothing and a face shield, or have a skilled technician do it.

**WARNING:** Battery posts, terminals, and related accessories contain lead and lead compounds. **Wash your hands after handling.**

## Window Washer Fluid

If the washer fluid level is low, fill the washer reservoir.

### Canadian models

If the washer fluid level is low, the washer level indicator or a message appears.



### NOTICE

Do not use engine antifreeze or a vinegar/water solution in the windshield washer reservoir. Antifreeze can damage your vehicle's paint. A vinegar/water solution can damage the windshield washer pump.

## Changing Wiper Blades

If the wiper blades leave streaks across the windshield, try cleaning them first with a paper towel or soft cloth and wiper fluid. If the wiper blade rubber has deteriorated, you should change the wiper blades.

1. Lift the driver side wiper arm first, then the passenger side.
2. Place a cloth on the edge of the lock tab. Push the lock tab up with a flat-tip screwdriver.
3. Slide the blade from the wiper arm.
4. Slide the wiper blade out from its holder by pulling the tabbed end out.
5. Remove the retainers from the rubber blade that has been removed, and mount to a new rubber blade. Correctly align the rubber protrusion and the retainer grooves.
6. Slide the new wiper blade onto the holder from the bottom end. The tab on the holder should fit in the indent of the wiper blade.
7. Slide the wiper blade onto the wiper arm, then push down the lock tab.
8. Lower the passenger side wiper arm first, then the driver side.

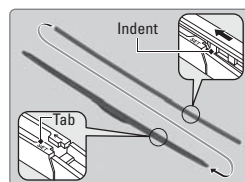
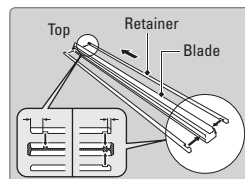
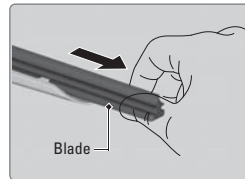
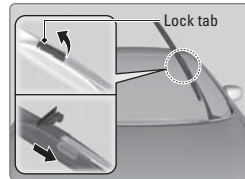
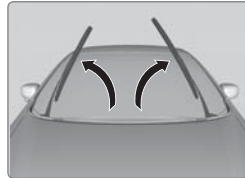

### NOTICE

Avoid dropping the wiper arm, as it may damage the windshield.

## Tire Information

To safely operate your vehicle, your tires must be of the proper type and size, in good condition with adequate tread, and properly inflated.

### Inflation Guidelines

- Properly inflated tires provide the best combination of handling, tread life, and comfort. Refer to the driver's doorjamb label or the specifications (see page 135) for the specified pressure.
- Underinflated tires wear unevenly, adversely affect handling and fuel economy, and are more likely to fail from overheating.
- Overinflated tires make your vehicle ride harshly, are more prone to road hazards, and wear unevenly.
- Every day before you drive, look at each of the tires. If one looks lower than the others, check the pressure with a tire gauge.
- Measure the air pressure when tires are cold. This means the vehicle has been parked for at least 3 hours, or driven less than 1 mile (1.6 km). If necessary, add or release air until the specified pressure is reached, and then calibrate the system (see page 107). If checked when hot, tire pressure can be as much as 4–6 psi (30–40 kPa, 0.3–0.5 kgf/cm<sup>2</sup>) higher than checked when cold.
- At least once a month or before long trips, use a gauge to measure the pressure in all tires, including the spare\*. Even tires in good condition can lose 1–2 psi (10–20 kPa, 0.1–0.2 kgf/cm<sup>2</sup>) per month.

### Inspection Guidelines

Every time you inflate the tires, check for the following:

- Any damage to tires, including bumps, bulges, cuts, splits, or cracks in the side or tread. Remove any foreign objects and inspect for air leaks. Replace tires if you see fabric or cord.
- Uneven or excessive tread wear. Have a dealer check the wheel alignment.
- Cracks or other damage around the valve stems.

### Wear Indicators

The groove where the wear indicator is located is 1/16 inch (1.6 mm) shallower than elsewhere on the tire. If the tread has worn so low that the indicator is exposed, replace the tire. **Worn out tires have poor traction on wet roads.**

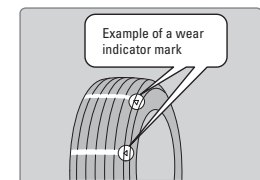

**⚠ WARNING**

Using tires that are excessively worn or improperly inflated can cause a crash in which you can be seriously hurt or killed.

Follow all instructions in this owner's manual regarding tire inflation and maintenance.

**■ Tire and Loading Information Label**

The label attached to the driver's doorjamb provides necessary tire and loading information.

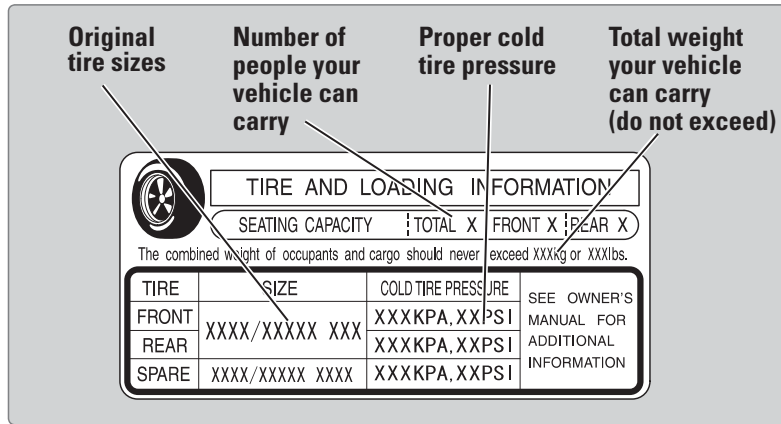

**■ Tire and Wheel Replacement**

Replace your tires with radials of the same size, load range, speed rating, and maximum cold tire pressure rating (as shown on the tire's sidewall). Using tires of a different size or construction can cause certain vehicle systems to work incorrectly. It is best to replace all four tires at the same time. If that isn't possible, replace the front or rear tires in pairs.

If you change or replace a wheel, make sure that the wheel's specifications match those of the original wheels. Only use TPMS-specified wheels approved for your vehicle.

**⚠ WARNING**

Installing improper tires on your vehicle can affect handling and stability.

This can cause a crash in which you can be seriously hurt or killed.

Always use the size and type of tires recommended in the Owner's Manual.

**■ Tire Service Life**

The life of your tires is dependent on many factors, including driving habits, road conditions, vehicle loading, inflation pressure, maintenance history, speed, and environmental conditions (even when the tires are not in use).

In addition to regular inspections and inflation pressure maintenance, it is recommended that you have annual inspections performed once the tires reach five years old. All tires, including the spare\*, should be removed from service after 10 years from the date of manufacture, regardless of their condition or state of wear.

**■ Winter Tires**

If driving on snowy or frozen roads, mount all season tires marked "M+S", snow tires, or tire chains; reduce speed; and maintain sufficient distance between vehicles when driving. For winter tires, select the size and load ranges that are the same as the original tires, and mount them to all four wheels.

**■ Tire Chains**

Install tire chains on the front tires only. Because your vehicle has limited tire clearance, we strongly recommend using the following chains:

**For P195/65R15 tires:**

Cable-type: SCC Radial Chain SC1030

**For P205/55R16 or P215/45R17 tires:**

Cable-type: SCC Radial Chain SC1032

**For P225/40R18 or 225/40R18 tires:**

These tires are not suitable for mounting any traction device.

Mount chains as tightly as you can, and make sure that they do not touch the brake lines or suspension.

**NOTICE**

Traction devices that are the wrong size or improperly installed can damage your vehicle's brake lines, suspension, body, and wheels. Stop driving if they are hitting any part of the vehicle.

**⚠ WARNING**

Using the wrong chains, or not properly installing chains, can damage the brake lines and cause a crash in which you can be seriously injured or killed.

Follow all instructions in this guide regarding the selection and use of tire chains.



## Tire Labeling

The tires that came on your vehicle have a number of markings. Those you should be aware of are described below.

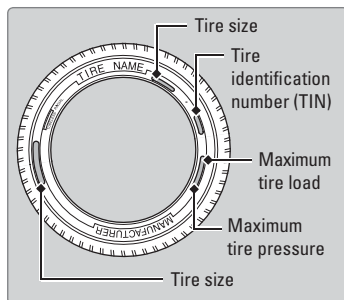

Here is an example of what each marking means:

### **P205/55R16 89H**

- P: Vehicle type (passenger)
- 205: tire width in millimeters
- 55: aspect ratio (tire section height as a percentage of its width)
- R: tire construction code (radial)
- 16: rim diameter in inches
- 89: load index (code indicating maximum load tire can carry)
- H: speed symbol (code indicating maximum speed rating)

### ■ Tire Identification Number (TIN)

The tire identification number (TIN) is a group of numbers and letters that look like the example below. TIN is located on the sidewall of the tire.

```

DOT B97R FW6X 2209
DOT: This indicates that the tire meets all
requirements of the U.S. Department of
Transportation.
B97R: Manufacturer's identification mark
FW6X: Tire type code
22 09: Date of Transportation
└─┬─┘
  Year
   Week
  
```

### ■ Glossary of Tire Terminology

**Cold Tire Pressure** – The tire air pressure when the vehicle has been parked for at least three hours or driven less than 1 mile (1.6 km).

**Load Rating** – The maximum load that a tire is rated to carry for a given inflation pressure.

**Maximum Inflation Pressure** – The maximum tire air pressure that the tire can hold.

**Maximum Load Rating** – The load rating for a tire at the maximum permissible inflation pressure for that tire.

**Recommended Inflation Pressure** – The cold tire inflation pressure recommended by the manufacturer.

**Treadwear Indicators (TWI)** – The projections within the principal grooves designed to give a visual indication of the degrees of wear of the tread.

## DOT Tire Quality Grading

The tires on your vehicle meet all U.S. Federal Safety Requirements. All tires are also graded for treadwear, traction, and temperature performance according to Department of Transportation (DOT) standards. The following explains these gradings.

### ■ Uniform Tire Quality Grading

Quality grades can be found where applicable on the tire sidewall between tread shoulder and maximum section width.

For example:

*Treadwear 200*

*Traction AA*

*Temperature A*

All passenger car tires must conform to Federal Safety Requirements in addition to these grades.

### ■ Treadwear

The treadwear grade is a comparative rating based on the wear rate of the tire when tested under controlled conditions on a specified government test course. For example, a tire graded 150 would wear one and one-half (1 1/2) times as well on the government course as a tire graded 100. The relative performance of tires depends upon the actual conditions of their use, however, and may depart significantly from the norm due to variations in driving habits, service practices, and differences in road characteristics and climate.

### ■ Traction

The traction grades, from highest to lowest, are AA, A, B, and C. Those grades represent the tire's ability to stop on wet pavement as measured under controlled conditions on specified government test surfaces of asphalt and concrete. A tire marked C may have poor traction performance.

**WARNING:** The traction grade assigned to this tire is based on straight-ahead braking traction tests, and does not include acceleration, cornering, hydroplaning, or peak traction characteristics.

### ■ Temperature

The temperature grades are A (the highest), B, and C, representing the tire's resistance to the generation of heat and its ability to dissipate heat when tested under controlled conditions on a specified indoor laboratory test wheel. Sustained high temperature can cause the material of the tire to degenerate and reduce tire life, and excessive temperature can lead to sudden tire failure. The grade C corresponds to a level of performance which all passenger car tires must meet under the Federal Motor Vehicle Safety Standard No. 109. Grades B and A represent higher levels of performance on the laboratory test wheel than the minimum required by law.

**WARNING:** The temperature grade for this tire is established for a tire that is properly inflated and not overloaded. Excessive speed, underinflation, or excessive loading, either separately or in combination, can cause heat buildup and possible tire failure.

### Tire Pressure Monitoring System (TPMS) - Required Federal Explanation

#### U.S. models

Each tire, including the spare (if provided), should be checked monthly when cold and inflated to the inflation pressure recommended by the vehicle manufacturer on the vehicle placard or tire inflation pressure label.

(If your vehicle has tires of a different size than the size indicated on the vehicle placard or tire inflation pressure label, you should determine the proper tire inflation pressure for those tires.)

As an added safety feature, your vehicle has been equipped with a tire pressure monitoring system (TPMS) that illuminates a low tire pressure telltale when one or more of your tires is significantly underinflated.



Accordingly, when the low tire pressure telltale illuminates, you should stop and check your tires as soon as possible, and inflate them to the proper pressure.

Driving on a significantly underinflated tire causes the tire to overheat and can lead to tire failure. Underinflation also reduces fuel efficiency and tire tread life, and may affect the vehicle's handling and stopping ability.

Please note that the TPMS is not a substitute for proper tire maintenance, and it is the driver's responsibility to maintain correct tire pressure, even if underinflation has not reached the level to trigger illumination of the TPMS low tire pressure telltale.

Your vehicle has also been equipped with a TPMS malfunction indicator to indicate when the system is not operating properly. The TPMS malfunction indicator is combined with the low tire pressure telltale. When the system detects a malfunction, the telltale will flash for approximately one minute and then remain continuously illuminated. This sequence will continue upon subsequent vehicle start-ups as long as the malfunction exists.

When the malfunction indicator is illuminated, the system may not be able to detect or signal low tire pressure as intended.

TPMS malfunctions may occur for a variety of reasons, including the installation of replacement or alternate tires or wheels on the vehicle that prevent the TPMS from functioning properly.

Always check the TPMS malfunction telltale after replacing one or more tires or wheels on your vehicle to ensure that the replacement or alternate tires and wheels allow the TPMS to continue to function properly.

### Testing of Readiness Codes

Your vehicle has “readiness codes” as part of the onboard self-diagnostic system. Some states refer to these codes as a test to see if your vehicle’s emissions components are working properly. The codes may not be read if you go through the testing just after the battery has gone dead or been disconnected.

To check if they are set, turn the vehicle on without starting the engine. The malfunction indicator lamp will come on for several seconds. If it goes off, the readiness codes are set. If it blinks five times, the readiness codes are not set.

If you are required to have your vehicle tested before the readiness codes are set, prepare the vehicle for retesting by doing the following:

1. Fill the gas tank to approximately 3/4 full.
2. Park the vehicle and leave the engine off for 6 hours or more.
3. Make sure the ambient temperature is between 40°F and 95°F (4°C and 35°C).
4. Start the engine without touching the accelerator pedal, and let it idle for 20 seconds.
5. Keep the vehicle in Park (P) or Neutral for manual transmission. Increase the engine speed to 2,000 rpm, and hold it there for about 3 minutes.
6. Let the engine idle with your foot off the accelerator for 20 seconds.
7. Select a nearby, lightly traveled major highway where you can maintain a speed of 50 to 60 mph (80 to 97 km/h) for at least 20 minutes. Drive on the highway with the vehicle in Drive (D) or 5th gear. Do not use cruise control. When traffic allows, drive for 90 seconds without using the accelerator pedal. (Vehicle speed may vary slightly; this is OK.) If you cannot do this for a continuous 90 seconds because of traffic conditions, drive for at least 30 seconds, then repeat two more times (for a total of 90 seconds).
8. Drive in city/suburban traffic for at least 10 minutes. When traffic conditions allow, let the vehicle coast for several seconds without using the accelerator pedal or the brake pedal.
9. Park the vehicle and leave the engine off for 30 minutes.

The readiness codes are erased when the battery is disconnected, and set again only after several days of driving under a variety of conditions.

If a testing facility determines that the readiness codes are not set, you may be requested to return at a later date to complete the test, or see your dealer.

## SPECIFICATIONS

### Civic Sedan

#### Vehicle

Model	Honda Civic 4-Door
Curb Weight	1,240-1,282 kg (2,734-2,826 lbs) <sup>*1</sup>
	1,275-1,311 kg (2,811-2,890 lbs) <sup>*2</sup>
Maximum permissible weight	1,660 kg (3,660 lbs) <sup>*3</sup>
	1,685 kg (3,715 lbs) <sup>*4</sup>
	1,720 kg (3,792 lbs) <sup>*5</sup>

- \*1: Manual transmission models
- \*2: Automatic transmission models
- \*3: LX and LX-C models with manual transmission
- \*4: LX and LX-C models with automatic transmission
- \*5: EX, EX-C, and EX-L models

#### Dimensions

Length	4,555 mm (179.3 in) <sup>*1</sup>
	4,570 mm (179.9 in) <sup>*2</sup>
	4,580 mm (180.3 in) <sup>*3</sup>
Width	1,755 mm (69.1 in)
Height	1,450 mm (57.1 in)
Wheelbase	2,670 mm (105.1 in)
Track	Front 1,492 mm (58.7 in)
	Rear 1,516 mm (59.7 in)

- \*1: LX, LX-C, EX, EX-C, and EX-L models without front licence plate base
- \*2: LX, LX-C, EX, EX-C, and EX-L models with front licence plate base
- \*3: LX, LX-C, EX, EX-C, and EX-L models with front licence plate bases

#### Engine and Fuel

Engine Specifications	
Displacement	110 cu-in (1,798 cm <sup>3</sup> )
Spark Plugs	NGK D1LZKR7B11GS
	DENSO DXU22HCR-D11S
Fuel	
Fuel Type	Unleaded gasoline, Pump octane number of 87 or higher
Fuel Tank Capacity	13.2 US gal (50 ℓ)

#### Tires

Regular	Size	215/70R16 100S <sup>*1</sup>	
		225/65R17 102T <sup>*2</sup>	
		P225/60R18 99H <sup>*3</sup>	
Compact Spare	Size	T165/80D17 104M	
		Pressure	32 (220 [2.2]) <sup>*1</sup>
		Pressure	33 (230 [2.3]) <sup>*2</sup>
Wheel Size	Regular	16 x 6.5J <sup>*1</sup>	
		17 x 7J <sup>*2</sup>	
		18 x 7J <sup>*3</sup>	
Compact Spare		17 x 4T	

- \*1: Vehicle with 16 inch wheel
- \*2: Vehicle with 17 inch wheel
- \*3: Vehicle with 18 inch wheel

#### Light Bulbs

Headlights (Low Beam)	55W (H11)
Headlights (High Beam)	60W (HB3)
Fog Lights*	35W (H8)
Front Turn Signal/Side Marker/Parking Lights*	28/8W (Amber)
Front Turn Signal/Side Marker Lights*	28/8W (Amber)
Side Turn Signal Lights (on Door Mirrors)*	LED
Parking Lights*	LED
Upper Rear Side Marker/Tailights	3CP
Lower Rear Side Marker/Brake/Tailights	21/5W
Back-Up Lights	21W
Rear Turn Signal Lights	21W (Amber)
High-Mount Brake Light	LED
Rear License Plate Light	3CP
Cargo Area Light	8W
Vehicle Mirror Lights*	1 AM

#### Fluids

##### Brake/Clutch Fluid

Specified	Honda Heavy Duty Brake Fluid DOT 3
-----------	------------------------------------

##### Automatic Transmission (CVT) Fluid

Specified	HCF-2
Capacity	Change 3.6 US qt (3.4 ℓ)

##### Manual Transmission Fluid

Specified	Honda Manual Transmission Fluid
Capacity	Change 1.5 US qt (1.4 ℓ)

##### Engine Oil

Recommended	Honda Genuine Motor Oil 0W-20	
	API Premium-grade 0W-20 detergent oil	
Capacity	Change	3.7 US qt (3.5 ℓ)
	Change including filter	3.9 US qt (3.7 ℓ)

##### Engine Coolant

Specified	Honda Long-Life Antifreeze/Coolant Type2
Ratio	50/50 with distilled water
Capacity	1.48 US gal (5.59 ℓ) (change including the remaining 0.125 US gal (0.475 ℓ) in the reserve tank)

##### Washer Fluid

Tank Capacity	U.S.: 2.6 US qt (2.5 ℓ) Canada: 4.8 US qt (4.5 ℓ)
---------------	--

Civic Sedan Si

■ Vehicle

Model	Honda Civic 4-Door	
No. of Passengers:		
Front	2	
Rear	3	
Total	5	
Weights:		
Gross Vehicle Weight Rating	U.S.: 3,925 lbs (1,780 kg)	Canada: 1,780 kg
Gross Axle Weight Rating (Front)	U.S.: 2,117 lbs (960 kg)	Canada: 960 kg
Gross Axle Weight Rating (Rear)	U.S.: 1,830 lbs (830 kg)	Canada: 830 kg
Air Conditioning:		
Refrigerant Type	HFC-134a (R-134a)	
Charge Quantity	13.2 – 15.0 oz (375 – 425 g)	
Lubricant Type	SP-10	

■ Engine and Fuel

Engine Specifications		
Displacement	144 cu-in (2,354 cm <sup>3</sup> )	
Spark Plugs	NGK ILZKR7B-11S	DENSO SXU22HCR11S
Fuel		
Fuel Type	Unleaded premium gasoline, Pump octane number of 91 or higher	
Fuel Tank Capacity	13.2 US gal (50 ℓ)	

■ Tires

Regular	Size	225/40R18 92V 225/40R18 92Y <sup>*1</sup>
	Pressure psi (kPa [kgf/cm <sup>2</sup> ])	33 (230 [2.3]) 32 (220 [2.2]) <sup>*1</sup>
Compact Spare	Size	T135/80D16 101M
Wheel Size	Regular	18 x 7 1/2J
	Compact Spare	16 x 4T

\*1: Optional for U.S. models (summer tires)

■ Light Bulbs

Headlights (Low Beam)	51W (HB4)
Headlights (High Beam)	60W (HB3)
Fog Lights	35W (H8)
Front Turn Signal/Parking/Side Marker Lights	28/8W (Amber)
Brake/Taillights	21/5W
Rear Turn Signal Lights	21W (Amber)
Rear Side Marker Lights	LED
Back-Up Lights	16W
Taillights	3CP
High-Mount Brake Light	LED
Rear License Plate Lights	5W
Trunk Light	5W
Interior Lights	
Map Lights	8W
Ceiling Light	8W

■ Fluids

Engine Oil	
Recommended	· Honda Genuine Motor Oil 0W-20 · API Premium-grade 0W-20 detergent oil
Capacity	Change including filter 4.2 US qt (4.0 ℓ) Change including filter 4.4 US qt (4.2 ℓ)
Engine Coolant	
Specified	Honda Long-Life Antifreeze/Coolant Type2
Ratio	50/50 with distilled water
Capacity	1.45 US gal (5.5 ℓ) (change including the remaining 0.125 US gal (0.475 ℓ) in the reserve tank)
Washer Fluid	
Tank Capacity	U.S.: 2.6 US qt (2.5 ℓ) Canada: 4.8 US qt (4.5 ℓ)

Civic Coupe

■ Vehicle

Vehicle Specifications	
Model	Honda Civic 2-Door
Curb Weight	1,279 kg (2,820 lbs) <sup>*1</sup> 1,306 kg (2,879 lbs) <sup>*2</sup>
Maximum permissible weight	1,720 kg (3,792 lbs)
*1: Manual transmission models *2: Automatic transmission models	
Dimensions	
Length	4,550 mm (179.1 in)
Width	1,755 mm (69.1 in)
Height	1,415 mm (55.7 in)
Wheelbase	2,620 mm (103.1 in)
Track	Front 1,492 mm (58.7 in) Rear 1,516 mm (59.7 in)

■ Engine and Fuel

Engine Specifications		
Displacement	110 cu-in (1,798 cm <sup>3</sup> )	
Spark Plugs	NGK DILZKR7B11GS	DENSO DXU22HCR-D11S
Fuel		
Fuel Type	Unleaded gasoline, Pump octane number of 87 or higher	
Fuel Tank Capacity	13.2 US gal (50 ℓ)	

■ Tires

Tires		
Regular	Size	P205/55R16 89H <sup>*1</sup> P215/45R17 87V <sup>*2</sup>
	Pressure psi(kPa[kgf/cm <sup>2</sup> ])	32 (220 [2.2])
Compact Spare	Size	T135/80D15 99M
	Pressure psi(kPa[kgf/cm <sup>2</sup> ])	60 (420 [4.2])
Wheel Size	Regular	16 x 6 1/2J <sup>*1</sup> 17 x 7J <sup>*2</sup>
	Compact Spare	15 x 4T

\*1: Except EX-L model  
\*2: EX-L model

■ Light Bulbs

Headlights (Low Beam)	55 W (H11)
Headlights (High Beam)	60 W (HB3)
Front Turn Signal/Position/Side Marker Lights	28/8 W
Brake/Taillights	21/5 W
Rear Side Marker Lights	5 W
Rear Turn Signal Lights	21 W (Amber)
Back-Up Lights	16 W
High-Mount Brake Light	21 W
Rear License Plate Light	5 W
Interior Lights	
Map Lights	8 W
Ceiling Light	8 W

■ Fluids

Engine Oil	
Recommended	Genuine Honda Motor Oil API service SL or higher grade 0W-30, 0W-40, 5W-30, 5W-40, 10W-30, 10W-40, 15W-40 Change 3.5 ℓ (3.7 US qt)
Capacity	Change including filter 3.7 ℓ (3.9 US qt)
Engine Coolant	
Specified	Honda All Season Antifreeze/Coolant Type2
Ratio	50/50 with distilled water
Capacity	5.59 ℓ (1.48 US gal) (change including the remaining 0.475 ℓ (0.125 US gal) in the reserve tank)

Brake/Clutch Fluid	
Specified	Brake Fluid with DOT3 or DOT4

Automatic Transmission Fluid	
Specified	Honda ATF DW-1 (automatic transmission fluid)
Capacity	Change 2.4 ℓ (2.5 US qt)

Manual Transmission Fluid	
Specified	Honda Manual Transmission Fluid
Capacity	Change 1.4 ℓ (1.5 US qt)

Washer Fluid	
Tank Capacity	2.5 ℓ (2.6 US qt)

Civic Coupe Si

■ Vehicle

Model	Honda Civic 2-Door
Curb Weight	1,374 kg (3,029 lbs)
Maximum permissible weight	1,780 kg (3,924 lbs)

Dimensions

Length	4,550 mm (179.1 in)
Width	1,755 mm (69.1 in)
Height	1,415 mm (55.7 in)
Wheelbase	2,620 mm (103.1 in)
Track	Front 1,496 mm (58.9 in) Rear 1,516 mm (59.7 in)

■ Engine and Fuel

Engine Specifications

Displacement	144 cu-in (2,354 cm <sup>3</sup> )
Spark Plugs	NGK ILZKR7B-11S DENSO SXU22CHR11S

Fuel

Fuel Type	Unleaded premium gasoline, Pump octane number of 91 or higher
Fuel Tank Capacity	13.2 US gal (50 ℓ)

■ Tires

Regular	Size	225/40R18 92V 225/40R18 92Y <sup>*1</sup>
	Pressure psi(kPa/kgf/cm <sup>2</sup> )	33 (230 [2.3]) 32 (220 [2.2]) <sup>*1</sup>
Compact Spare	Size	T135/80D16 101M
	Pressure psi(kPa/kgf/cm <sup>2</sup> )	60 (420 [4.2])
Wheel Size	Regular	18 x 7 1/2J
	Compact Spare	16 x 4T

\*1: Optional for U.S. models (summer tires)

■ Light Bulbs

Headlights (Low Beam)	55 W (H11)
Headlights (High Beam)	60 W (HB3)
Fog Lights	55 W (H11)
Front Turn Signal/Position/Side Marker Lights	28/8 W
Brake/Taillights	21/5 W
Rear Side Marker Lights	5 W
Rear Turn Signal Lights	21 W (Amber)
Back-Up Lights	16 W
High-Mount Brake Light	LED
Rear Licence Plate Light	5 W
Interior Lights	
Map Lights	8 W
Ceiling Light	8 W

■ Fluids

Engine Oil

Recommended	Genuine Honda Motor Oil API service SM or higher grade 0W-30, 0W-40, 5W-30, 5W-40, 10W-30, 10W-40, 15W-40
	Change 4.0 ℓ (4.2 US qt)
Capacity	Change including filter 4.2 ℓ (4.4 US qt)

Engine Coolant

Specified	Honda All Season Antifreeze/Coolant Type2
Ratio	50/50 with distilled water
Capacity	5.5 ℓ (1.45 US gal) (change including the remaining 0.475 ℓ (0.125 US gal) in the reserve tank)

Brake/Clutch Fluid

Specified	Brake Fluid with DOT3 or DOT4
-----------	-------------------------------

Manual Transmission Fluid

Specified	Honda Manual Transmission Fluid
Capacity	Change 1.9 ℓ (2.0 US qt)

Civic Natural Gas (CNG)

■ Vehicle

Model	Honda Civic 4-Door Natural Gas
No. of Passengers:	
Front	2
Rear	3
Total	5
Weights:	
Gross Vehicle Weight Rating	3,870 lbs (1,755 kg)
Gross Axle Weight Rating (Front)	2,007 lbs (910 kg)
Gross Axle Weight Rating (Rear)	1,863 lbs (845 kg)
Air Conditioning:	
Refrigerant Type	HFC-134a (R-134a)
Charge Quantity	13.2 – 15.0 oz (375 – 425 g)
Lubricant Type	SP-10

■ Engine and Fuel

Engine Specifications

Displacement	110 cu-in (1,798 cm <sup>3</sup> )
Spark Plugs	NGK SILKR8B8DS

Fuel

Fuel Tank Service Pressure	3,600 psi (24,800 kPa) at 70°F (21°C)
Fuel Tank Capacity	3,000 psi: Slow filling 6.96 GGE Fast filling 5.84 GGE
	3,600 psi: Slow filling 7.77 GGE Fast filling 6.51 GGE

■ Tires

Regular	Size	P195/65R15 89H
	Pressure psi (kPa/kgf/cm <sup>2</sup> )	30 (210 [2.1])
Compact Spare <sup>*1</sup>	Size	T135/80D15 99M
	Pressure psi (kPa/kgf/cm <sup>2</sup> )	60 (420 [4.2])
Wheel Size	Regular	15 x 6J
	Compact Spare <sup>*1</sup>	15 x 4T

\*1: Models with compact spare tire

■ Light Bulbs

Headlights (Low Beam)	51W (HB4)
Headlights (High Beam)	60W (HB3)
Front Turn Signal/Parking/Side Marker Lights	28/8W (Amber)
Brake/Taillights	21/5W
Rear Turn Signal Lights	21W (Amber)
Rear Side Marker Lights	LED
Back-Up Lights	16W
Taillights	3CP
High-Mount Brake Light	21W
Rear License Plate Lights	5W
Trunk Light	5W
Interior Lights	
Map Lights	8W
Ceiling Light	8W

■ Fluids

Brake Fluid

Specified	Honda Heavy Duty Brake Fluid DOT 3
-----------	------------------------------------

Automatic Transmission Fluid

Specified	Honda ATF DW-1 (automatic transmission fluid)
-----------	---

Capacity Change 2.5 US qt (2.4 ℓ)

Engine Oil

Recommended	• Honda Genuine Motor Oil 0W-20
	• API Premium-grade 0W-20 detergent oil
Capacity	Change 3.7 US qt (3.5 ℓ)
	Change including filter 3.9 US qt (3.7 ℓ)

Engine Coolant

Specified	Honda Long-Life Antifreeze/Coolant Type2
Ratio	50/50 with distilled water
Capacity	1.45 US gal (5.50 ℓ) (change including the remaining 0.125 US gal (0.475 ℓ) in the reserve tank)

Washer Fluid

Tank Capacity	2.6 US qt (2.5 ℓ)
---------------	-------------------

## CUSTOMER INFORMATION

Learn about information specific to you as a Honda customer and how to get help.

### Frequently Asked Questions/Troubleshooting

Below are some frequently asked questions and troubleshooting items that you may have about the vehicle.

- Q:** *How do I set the vehicle clock?*
- A:** For vehicles without navigation, see page 44. For vehicles with navigation, the time is automatically set using GPS signals.
- Q:** *Why doesn't the vehicle start when I press the ENGINE START/STOP button?\**
- A:** The brake pedal must be pressed to start the engine.
- Q:** *What is the AUTO setting on my headlight lever?*
- A:** When in the AUTO position, the vehicle's exterior lights will automatically turn on or off depending on the ambient lighting.
- Q:** *Why won't the driver's door unlock when I grab the door handle, even though the keyless access remote is within range?\**
- A:** If you pull the handle too quickly, the system may not have time to confirm the door is unlocked. Wait to hear a beep to confirm the door is unlocked. If you are wearing gloves, the system may be slow to respond.
- Q:** *After my battery was disconnected or went dead, the audio system is asking for a code. Where do I find this?*
- A:** In most cases, you do not need to enter a code. Turn on the vehicle and the audio system, and press and hold the power button until the system reactivates.
- Q:** *Why can't I operate Pandora® through the audio system?\**
- A:** Audio may be streaming through *Bluetooth®* Audio. Make sure Pandora mode is selected and the phone cable is properly connected to the USB adapter cable (if using). Some phones may prompt you to "Allow" a connection.
- Q:** *Is my phone compatible with Bluetooth features?*
- A:** Visit [handsfreelink.com](http://handsfreelink.com) (U.S.) or [www.handsfreelink.ca](http://www.handsfreelink.ca) (Canada) to check phone compatibility for *Bluetooth®* Audio, *Bluetooth®* HandsFreeLink®, and SMS text messaging.
- Q:** *Every time I press the Talk button, the system gives me voice prompts. Can I turn these off?\**
- A:** From the Home screen, select SETTINGS. Select System, then select Voice Prompt. Select Off.

*\*if equipped*

### Contact Us

Honda dealer personnel are trained professionals. They should be able to answer all your questions. If you encounter a problem that your dealership does not solve to your satisfaction, please discuss it with the dealership's service manager or general manager. If you are dissatisfied with the decision made by the dealership's management, contact Honda Automobile Customer Service.

#### U.S. Owners:

American Honda Motor Co., Inc.  
Honda Automobile Customer Service  
1919 Torrance Blvd.  
Mail Stop 500-2N-7A  
Torrance, CA 90501-2746  
Tel: (800) 999-1009

#### In Puerto Rico and the U.S. Virgin Islands:

Bella International  
P.O. Box 190816  
San Juan, PR 00919-0816  
Tel: (787) 620-7546

#### Canadian Owners:

Honda Canada, Inc.  
Customer Relations  
180 Honda Blvd.  
Markham, ON  
L6C 0H9  
Tel: (888) 946-6329  
Fax: (877) 939-0909  
e-mail: [honda\\_cr@ch.honda.com](mailto:honda_cr@ch.honda.com)

When you call or write, please give us the following information:

- Vehicle Identification Number
- Date of purchase
- Odometer reading of your vehicle
- Your name, address, and telephone number
- A detailed description of the problem
- Name of the dealer who sold the vehicle to you

### Honda Roadside Assistance

24-hour emergency road service is available to you in the United States and Canada throughout your 3-year/36,000-mile warranty term. Services include jump starting, flat tire and lockout assistance, towing, and more (limitations apply). Call (866) 864-5211 (U.S.) or (800) 465-7587 (Canada).

*\*if equipped*



## Warranty Coverages

Below is a brief summary of the warranties covering your new vehicle.

**New Vehicle Limited Warranty:** Covers your new vehicle, except for the emissions control system and accessories, against defects in materials and workmanship.

**Emissions Control Systems Defects Warranty and Emissions Performance Warranty:** Covers your vehicle's emissions control systems. Time, mileage, and coverage are conditional.

**Seat Belt Limited Warranty:** Covers seat belts that fail to function properly.

**Rust Perforation Limited Warranty:** Covers all exterior body panels that rust through from the inside.

**Accessory Limited Warranty:** Covers Honda accessories.

**Replacement Parts Limited Warranty:** Covers all Honda replacement parts against defects in materials and workmanship.

**Replacement Battery Limited Warranty:** Provides prorated coverage for a replacement battery purchased from a Honda dealer.

**Replacement Muffler Lifetime Limited Warranty:** Covers a replacement muffler for the duration of the ownership.

Restrictions and exclusions apply to all these warranties. See the Warranty Manual on the Owner Information CD or at [owners.honda.com](http://owners.honda.com) (U.S.) or [myhonda.ca](http://myhonda.ca) (Canada) for complete descriptions of each warranty, including time, mileage, and other conditional limitations.

Your vehicle's original tires are covered by their manufacturer. Tire warranty information can be found on the Owner Information CD or at [owners.honda.com](http://owners.honda.com) (U.S.) or [myhonda.ca](http://myhonda.ca) (Canada).

## VOICE COMMAND INDEX

Learn about all available voice commands to help you operate the vehicle. Available on vehicles with navigation.

Press the Talk button before you say a command. To view a list of available commands in the vehicle, say "Voice help." Select a category to hear the commands read aloud.

### ■ Global Commands

The system accepts these commands on any screen.

- Voice help
- Display menu
- Display setting
- Display navigation
- Display information
- Display voice portal
- Display audio
- Display phone
- Back
- What is today's date?
- What time is it?

### ■ Navigation Commands

The system accepts these commands on the map/guidance screen.

#### General Commands

- Display map
- Go home 1 (or 2)
- Display voice portal

#### Route Commands

The system accepts these commands when a route is set.

- How long to the destination?
- How far to the destination?
- Display destination map
- Display entire route
- Cancel route
- Repeat guidance

#### Map Display Commands

- Display current location
- Display/Hide (specify icon type):
  - ATM
  - gas station
  - restaurant
  - post office
  - grocery store
  - lodging (hotel, motel)
  - parking garage
  - parking lot
  - school
  - hospital
  - freeway exit information
  - traffic
  - traffic speeds
  - traffic icons
  - traffic incidents
- Display north up
- Display heading up
- Display 3D map
- Display zoom in
- Display zoom out

## ■ Navigation Commands (continued)

### Find Place Commands

#### • Find nearest (specify place):

- Fuel and auto
- Honda dealers
- Gas station
- Auto parts & electronics
- Auto repair & maintenance
- Car wash & detailing
- Motorcycle dealers
- Other car dealer
- Roadside assistance
- ATM
- Bank
- Check cashing
- Community
- Business
- City hall
- Civic center
- Convention center
- Court house
- Higher education
- Library
- Post office
- School
- Emergency room
- Hospital
- Police station
- Veterinarian
- Lodging
- Bed & breakfast
- Hotel
- Recreation
- Amusement park
- Golf course
- Historical monument
- Marina
- Movie theater
- Museum
- Park
- Performing arts
- Sports complex
- Tourist attraction
- Restaurant
- American restaurant
- Californian restaurant
- Chinese restaurant
- Coffee shop
- Continental restaurant
- Fast food
- French restaurant
- German restaurant
- Greek restaurant
- Indian restaurant
- Italian restaurant
- Japanese restaurant
- Korean restaurant
- Mexican restaurant
- Pizza
- Seafood restaurant
- Thai restaurant
- Vegetarian restaurant
- Vietnamese restaurant
- Other restaurant
- Shopping area
- Accessory store
- Book store
- Clothing store
- Grocery store
- Home improvement store
- Mall
- Office supply store
- Pharmacy
- Pet food store
- Sewing store
- Shoe store
- Sporting goods store
- Toy store
- Travel center
- Airport
- Automobile club
- Bus station
- Camping

- Commuter rail station
- Ferry terminal
- Named place
- Park & ride
- Parking garage
- Parking lot
- Rental car agency
- Rest area
- Ski area
- Tourist information
- Train station
- Travel agency
- Truck stop

## ■ Climate Control Commands\*\*

The system accepts these commands on most screens.

- Climate control automatic (maintains selected temperature)
- Climate control on\*
- Climate control off\*
- Air conditioner on\*
- Air conditioner off\*
- Climate control defrost on\*
- Climate control defrost off\*
- Rear defrost on\*
- Rear defrost off\*
- Climate control fresh air
- Climate control recirculate
- Climate control vent
- Climate control bi-level (vent and floor)
- Climate control floor
- Climate control floor and defrost
- Fan speed up
- Fan speed down
- Fan speed # (#: 1 to 7)
- Temperature # degrees (#: 57 to 87°F)
- Temperature up
- Temperature down
- Temperature max hot
- Temperature max cold

## ■ Phone Commands

The system accepts these commands on most screens.

- Dial/call by number
- Dial/call by name
- Call (phone number or name)

## ■ Info Commands

The system accepts these commands on most screens.

- Trip computer
- Display traffic list\*
- Display traffic on my route\*
- Display clock
- Display wallpaper

## ■ On-screen Commands

The system accepts these commands on any screen where applicable. All available commands are highlighted in yellow when you press the Talk button.

- Next (or Down)
- Previous (or Up)
- Right (or Left)
- Return
- OK
- Delete

\* These commands toggle the function on and off, so the command may not match your intended action.

\*\*if equipped

**Audio Commands**

The system accepts these commands on most screens. Audio volume levels cannot be controlled using voice commands.

**FM/AM Radio Commands**

- Audio on\*
- Audio off\*
- Radio on\*
- Radio off\*
- Radio select FM
- Radio select AM
- Radio tune to # FM (#: frequency, e.g., 95.5)
- Radio tune to # AM (#: frequency, e.g., 1020)
- Radio seek up
- Radio seek down
- Radio next station
- Radio preset # (#: 1 to 12)
- Radio FM preset # (#: 1 to 12)
- Radio AM preset # (#: 1 to 6)

**Disc Commands**

- Disc play
- Disc play track # (#: 1 to 30)
- Disc skip forward
- Disc skip back
- Disc track random\*
- Disc track repeat\*
- Disc track scan\*
- Disc folder up
- Disc folder down
- Disc folder random\*
- Disc folder repeat\*
- Disc folder scan\*
- Disc normal play

**SiriusXM® Radio Commands**

- Radio select XM
- XM channel # (#: 0 to 255)
- XM channel up
- XM channel down
- XM category up
- XM category down
- XM preset # (#: 1 to 12)
- XM scan\*
- XM category scan\*
- XM channel scan\*
- XM category mode
- XM channel mode
- Radio scan\*

**USB Commands**

- USB play
- USB play track # (#: 1 to 30)
- USB skip forward
- USB skip back
- USB track random\*
- USB track repeat\*
- USB track scan\*
- USB folder up
- USB folder down
- USB folder random\*
- USB folder repeat\*
- USB folder scan\*
- USB normal play

*\*These commands toggle the function on and off, so the command may not match your intended action.*

**Audio Commands (continued)****iPod® Commands**

- Music search
- iPod play
- iPod play track # (#: 1-30)
- iPod skip forward
- iPod skip back
- iPod track shuffle\*
- iPod album shuffle\*
- iPod track repeat\*
- iPod normal play
- What/Who am I listening to?
- Who is this?
- What's playing?
- Who's playing?
- What album is this?

**Pandora® Commands**

- Pandora play\*
- Pandora skip forward
- Pandora station up
- Pandora station down
- Pandora pause\*
- Pandora resume\*
- Pandora like this song
- Pandora dislike this song

**Bluetooth® Audio Commands**

- Bluetooth audio play
- Bluetooth audio skip forward
- Bluetooth audio skip back
- Bluetooth audio pause
- Bluetooth audio resume
- Bluetooth audio group up
- Bluetooth audio group down

Commands may not work on some phones or devices.

**AUX Commands**

- Auxiliary play (for HDMI video)

*\*These commands toggle the function on and off, so the command may not match your intended action.*

## INDEX

ABS	24
Accessory Power Socket	45
Airbags	8
Air Conditioning System	41
Ambient meter	26, 94
Anti-lock Brake System (ABS)	24, 93
Audio Operation	45, 50
Audio Commands	146
Auxiliary Input Jack	45
Bluetooth® Audio	55, 64
Compact Disc (CD)	49, 52, 61
FM/AM Radio	48, 51, 59
HDMI Port	45
HDMI Video	66
iPod®	53, 62
Pandora®	56, 65
SiriusXM® Radio	60
Sound	47
Steering Wheel Controls	46
Touchscreen Operation	57
USB Flash Drive	54, 63
USB Port	45
Battery	125
Bluetooth® Audio	55, 64
Bluetooth® Audio Commands	147
Bluetooth® Handsfreelink® (HFL)	67
Dialing a Number	69, 74
E-Mail	76
HFL Controls	67, 71
HondaLink™ Assist	77
Making a Call	69, 74
Pairing a Phone	68, 73
Phonebook	69, 74
Siri™ Eyes Free	77
SMS Text Messaging	70, 76
Speed Dial	69, 75
Voice Recognition Tips	72
Brake Assist System	93
Brake system	23, 24
Braking	93
Brightness Control	34
Carbon Monoxide Gas	4
Changing a Flat Tire	108
Changing Settings	43
Charging system	23
Child Safety	14
Childproof Door Locks	31
Child Seat	16
Adding Security with a Tether	19
LATCH-Compatible Child Seat	17
Climate Control Commands	145
Climate Control System	42
Clock	44
Compact Disc (CD)	49, 52, 61
Compact Disc Commands	146
Condition Indicators	25
Contact Us	141
Continuously Variable Transmission (CVT)	91
Cruise Control	26, 95
Customer Information	140
Customized Features	43
Dashboard, Ceiling, and Other Controls	2
Daytime Running Lights (DRL)	24
Destination	81
Detour	84
Dialing a Number	69, 74
Door Mirrors	40
Door Operation	31
DOT Tire Quality Grading	131
Driver's Seat	36
Driving	85
Braking	93
Continuously Variable Transmission (CVT)	91
Cruise Control	95
Eco Assist System	94
ENGINE START/STOP button	91
Ignition	90
LaneWatch™	96
Manual Transmission	92
Maximum Load Limit	87
Paddle Shifters	92
Power Mode	91
Refueling	99
Shifting	91
Vehicle Stability Assist (VSA®)	94
Wiper Blades	126
DRL	24
Eco Assist System	94
ECON Button	94
ECON mode	26
Electric Power Steering (EPS)	24
Electronic Stability Control (ESC)	94
E-Mail	76
Emergency Engine Stop	106
Emergency Towing	106
Engine Specs	135, 136, 137, 138, 139
Engine Coolant	124
Engine Oil	121
ENGINE START/STOP button	91
Exterior Lights	34
Fastening a Seat Belt	7
Find Nearest Place	82
Find Place Commands	144

Flat Tire	108
Floor Mats	37
Fluids	135, 136, 137, 138, 139
FM/AM Radio	48, 51, 59
FM/AM Radio Commands	146
Foot Brake	93
Frequently Asked Questions	140
Front Airbags (SRS)	8
Front Door Inner Handle	31
Fuel gauge	26
Fuel Information	99, 100
Fuse Locations	112
Gauges	26
HDMI Port	45
HDMI Video	66
Headlight-Wiper Integration	35
Head Restraints	38
High temperature	24
Home Address	81
HondaLink™	58
HondaLink™ Assist	77
Honda Roadside Assistance	141
Hood	119
Ignition	90
i-MID	28
Immobilizer	26
Info Commands	145
Information Display	27
Instant fuel economy gauge	26
Instrument Panel	23
Intelligent Multi-Information Display (i-MID)	28
Interior Lights	34
Intermittent Wipers	35
iPod®	53, 62
iPod® Commands	147
i-VTEC indicator	26
Jump Starting	103
LaneWatch™	96
Lap/Shoulder Seat Belts	5
LATCH-Compatible Child Seat	17
Light Bulbs	135, 136, 137, 138, 139
Lights	26, 34
Lock Tab	31
Low fuel	25
Low oil pressure	23
Low temperature	24
Low tire pressure	25
Maintenance	115
Battery	125
Engine Coolant	124
Engine Oil	121
Maintenance Minder™	116
Service Codes	117
Under the Hood	119
Window Washer Fluid	125
Making a Call	69, 74
Malfunction indicator lamp	24
Malfunction Indicators	23
Manual Transmission	92
Map Display Commands	143
Map Legend	83
Master Door Lock Switch	31
Maximum Load Limit	87
Mirrors	40
Moonroof	33
Multi-View Rear Camera	98
Navigation	78
Detour	84
Display and Controls	79
Entering a Destination	81
Find Nearest Place	82
Home Address	81
Map Legend	83
Navigation Commands	143
Place Category	82
Routing	83
Steering Wheel Controls	78
Street Address	81
Traffic	84
Turn-by-Turn Directions	83
Voice Recognition Tips	80
Voice Prompt	80
One-Touch Turn Signal	35
On/Off Indicators	26
On-screen Commands	145
Opening the Hood	120
Overheating	105
Paddle Shifters	92
Pairing a Phone	68, 73
Pandora®	56, 65
Pandora® Commands	147
Parking brake	25, 93
Passenger Airbag Off Indicator	11
Phone	68, 73
Phonebook	69, 74
Phone Commands	145
Place Category	82
Power Door Mirrors	40
Power Driver's Seat	36
Power Mode	91
Power Moonroof Operation	33
Power Window Lock	32
Power Window Operation	32
Radio	48
Readiness Codes	134
Rear Seats	39
Rearview Camera	97
Rearview Mirror	40
Refueling	99

Remote Battery Strength .....	103	Wear Indicators .....	127
Remote Transmitter .....	29	Winter Tires.....	129
Reporting Safety Defects.....	22	Tire Pressure Monitoring System (TPMS) .....	24, 107, 133
Rev indicator.....	26	Tire Repair Kit.....	111
Roadside Assistance.....	141	Tire Service Life.....	129
Route Commands.....	143	Touchscreen Operation .....	57
Routing 83		Towing .....	106
Safety Information .....	3	Towing a Trailer.....	89
Airbags.....	8	TPMS .....	24, 107, 133
Child Safety.....	14	Traffic .....	84
Reporting Safety Defects.....	22	Trip Computer .....	28
Safety Label Locations.....	21	Troubleshooting.....	140
Seat Belts.....	5	Trunk Opener .....	31
Seat Belts.....	5	Turn-by-Turn Directions.....	83
Fastening a Seat Belt .....	7	Turn Signal .....	35
Seat Belt Inspection .....	6	USB Commands.....	146
Seat Belt Reminder.....	25	USB Flash Drive.....	54, 63
Shoulder Anchor .....	7	USB Port.....	45
Seat Heaters.....	42	Vehicle Specs.....	135, 136, 137, 138, 139
Seats .....	36	Vehicle Stability Assist (VSA®) .....	24, 26, 94
Service Codes.....	117	Visual Index.....	1
Settings .....	43	Voice Command Index .....	143
Setting the Clock.....	44	Voice Prompt .....	80
Shifting .....	91	Voice Recognition Tips.....	72, 80
Shift Lever Does Not Move .....	104	VSA® .....	24, 26, 94
Shoulder Anchor .....	7	Warranty Coverages .....	142
Side Airbags.....	9	Washer fluid level .....	26
Side Curtain Airbags.....	9	Wear Indicators .....	127
Siri™ Eyes Free .....	77	Windows.....	32
SiriusXM® Radio.....	60	Window Washer Fluid.....	125
SiriusXM® Radio Commands.....	146	Winter Tires.....	129
Smart Entry system.....	23, 30	Wiper Blades.....	126
SMS Text Messaging .....	70, 76	Wiper Operation.....	35
Sound .....	47		
Specifications.....	135		
Speed Dial.....	69, 75		
Speedometer .....	26		
Steering Wheel.....	40		
Steering Wheel and Nearby Controls .....	1		
Steering Wheel Controls.....	46, 78		
Street Address.....	81		
Supplemental Restraint System (SRS) ..	10, 23		
System message .....	26		
Text Messaging .....	70, 76		
Tire Information .....	127		
DOT Tire Quality Grading .....	131		
Inflation Guidelines.....	127		
Specifications.....	135, 136, 137, 138, 139		
Tire and Loading Information Label ...	128		
Tire and Wheel Replacement.....	128		
Tire Chains.....	129		
Tire Identification Number (TIN).....	130		
Tire Labeling.....	130		
Tire Service Life.....	129		
Tire Terminology.....	130		