

# Automatic Transmission Fluid

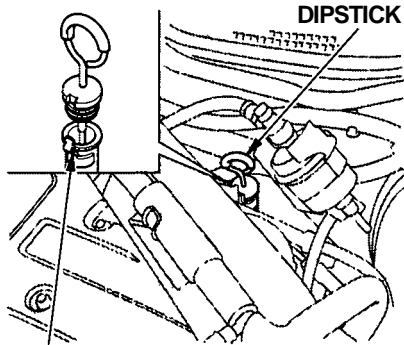

## DIPSTICK GUIDE

Check the fluid level with the engine at normal operating temperature.

1. Park the car on level ground. Shut off the engine.
2. Remove the dipstick (yellow loop) from the transmission and wipe it with a clean cloth.

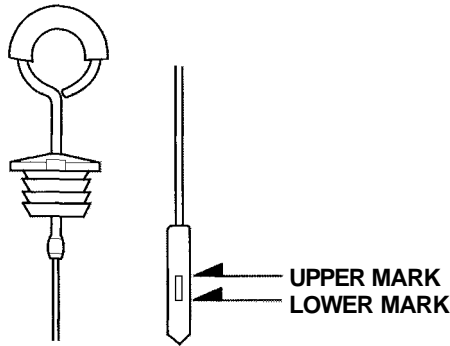

3. Insert the dipstick into the transmission. Make sure the notch in the rubber cap fits in the dipstick guide and that you push the dipstick in all the way.
4. Remove the dipstick and check the fluid level. It should be between the upper and lower marks.

5. If the level is below the lower mark, add fluid into the tube to bring it to the upper mark. Always use Honda Premium Formula Automatic Transmission Fluid (ATF). If it is not available, you may use a DEXRON® III automatic transmission fluid as a temporary replacement. However, continued use can affect shift quality. Have the transmission drained and refilled with Honda ATF as soon as it is convenient.
6. Insert the dipstick back in the transmission. Make sure the notch fits in the dipstick guide and the dipstick is down all the way.

The transmission should be drained and refilled with new fluid according to the time and distance recommendations in the maintenance schedule.

## Differential Oil

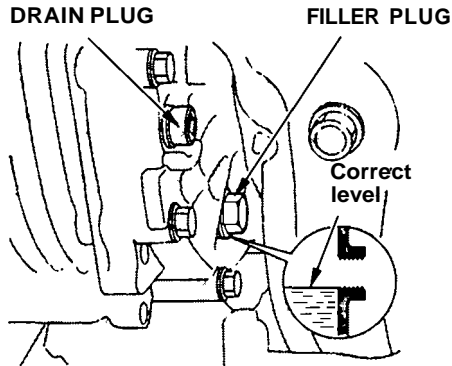

Check the oil in the differential with the car sitting level. Remove the oil filler plug and check that the oil level is up to the edge of the hole.

If it is not, slowly add oil until it starts to run out of the hole. Reinstall the filler plug and tighten it securely.

Use a SAE 90 or SAE 80W-90 viscosity hypoid gear oil, API service classified GL4 or GL5 only, in the differential.

### Viscosity

SAE 90: above 0°F ( — 18°C)

SAE 80W-90: below 0°F ( — 18°C)

The differential oil should be drained and refilled with new oil according to the time and distance recommendations in the maintenance schedule.

## Brake Fluid

Check the fluid level in the brake fluid reservoir monthly.

The brake fluid should be replaced according to the time and distance recommendations in the maintenance schedule.

CONTINUED

## Brake Fluid, Power Steering

Always use Genuine Honda DOT 3 brake fluid. If it is not available, you should use only DOT 3 or DOT 4 fluid, from a sealed container, as a temporary replacement. However, the use of any non-Honda brake fluid can cause corrosion and decrease the life of the system. Have the brake system flushed and refilled with Honda DOT 3 brake fluid as soon as possible.

Brake fluid marked DOT 5 is not compatible with your car's braking system and can cause extensive damage.

### Brake System

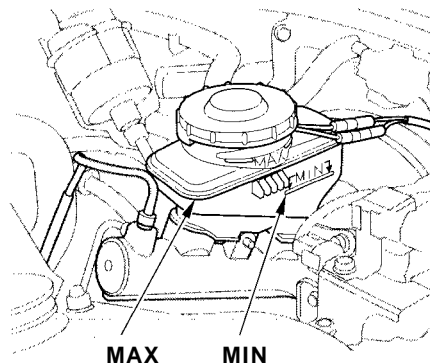

The fluid level should be between the MIN and MAX marks on the side of the reservoir. If the level is at or below the MIN mark, your brake system needs attention. Have the brake system inspected for leaks or worn brake pads.

### Power Steering

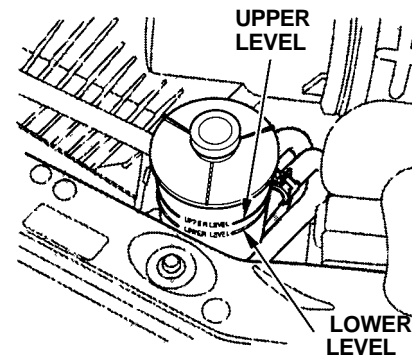

Check the level when the engine is cold. Look at the side of the reservoir. The fluid should be between the UPPER LEVEL and LOWER LEVEL. If it is below the LOWER LEVEL, add power steering fluid to the UPPER LEVEL.

# Power Steering, Hood Latch, Air Cleaner Element

Always use Genuine Honda Power Steering Fluid. If it is not available, you may use another power steering fluid as an emergency replacement. However, continued use can cause increased wear and poor steering in cold weather. Have the power steering system flushed and refilled with Honda PSF as soon as possible.

A low power steering fluid level can indicate a leak in the system. Check the fluid level frequently and have the system inspected as soon as possible.

## NOTICE

*Turning the steering wheel to full left or right lock and holding it there can damage the power steering pump.*

## Hood Latch

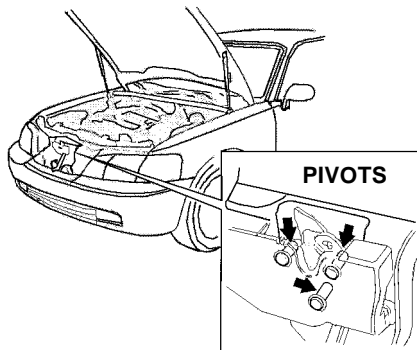

Clean the hood latch assembly with a mild cleaner, then lubricate it with a multipurpose grease. Lubricate all the moving parts, including the pivot. Follow the time and distance recommendations in the Maintenance Schedule. If you are not sure how to clean and grease the latch, contact your Acura dealer.

## Air Cleaner Element

The air cleaner element should be cleaned or replaced according to the time and distance recommendations in the maintenance schedule.

### Cleaning (Severe Conditions)

Clean the air cleaner element by blowing compressed air through it in the opposite direction to normal air flow. If you do not have access to compressed air (such as a service station), ask your Acura dealer to do this service.

Follow the replacement procedure for removal and reinstallation.

# Air Cleaner Element

## Replacement

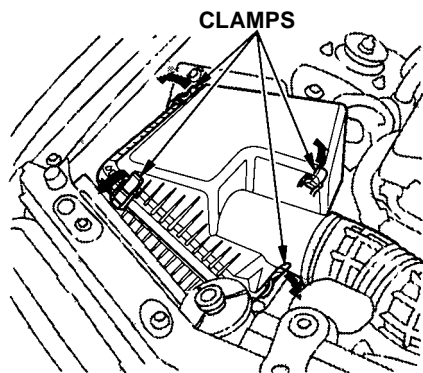

The air cleaner element is inside the air cleaner housing on the passenger's side of the engine compartment.

To replace it:

1. Unsnap the four clamps holding the air cleaner housing cover.

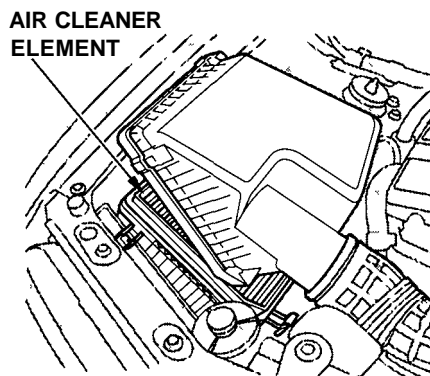

2. Remove the air cleaner housing cover. Do not disconnect the air intake tube from the air cleaner housing cover.
3. Remove the old air cleaner element.
4. Carefully clean the inside of the air cleaner housing with a damp rag.

5. Place the new air cleaner element in the air cleaner housing.
6. Reinstall the air cleaner housing cover, snap the four hold-down clamps back into place.