

Power Steering Fluid

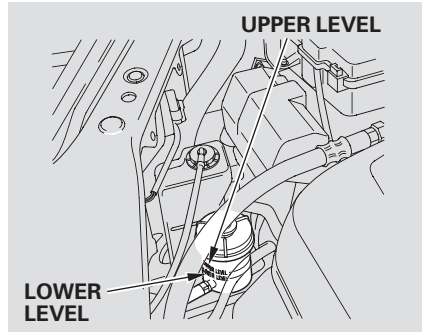

Check the level on the side of the reservoir when the engine is cold. The fluid should be between the UPPER LEVEL and LOWER LEVEL. If not add power steering fluid to the UPPER LEVEL mark.

Always use Honda Power Steering Fluid. You may use another power steering fluid as an emergency replacement, but have the power steering system flushed and refilled with Honda PSF as soon as possible.

A low power steering fluid level can indicate a leak in the system. Check the fluid level frequently, and have the system inspected as soon as possible.

NOTICE: *Turning the steering wheel to full left or right lock and holding it there can damage the power steering pump.*

Timing Belt

The timing belt should be replaced at the intervals shown in the maintenance schedule.

Replace the belt at 60,000 miles (100,000 km) if you regularly drive your vehicle in one or more of these conditions:

- In very high temperatures (over 110°F, 43°C).
- In very low temperatures (under -20°F, -29°C).
- Frequently tow a trailer.

Hood Latch, Lights

Headlight Aiming

The headlights were properly aimed when your vehicle was new. If you regularly carry heavy items in the cargo area or pull a trailer, readjustment may be required. Adjustment should be done by an Acura dealer or other qualified mechanic.

Replacing a Headlight Bulb

Your vehicle has halogen headlight bulbs, two on each side. When replacing a bulb, handle it by its base and protect the glass from contact with your skin or hard objects. If you touch the glass, clean it with denatured alcohol and a clean cloth.

NOTICE: *Halogen headlight bulbs get very hot when lit. Oil, perspiration, or a scratch on the glass can cause the bulb to overheat and shatter.*

1. Open the hood.

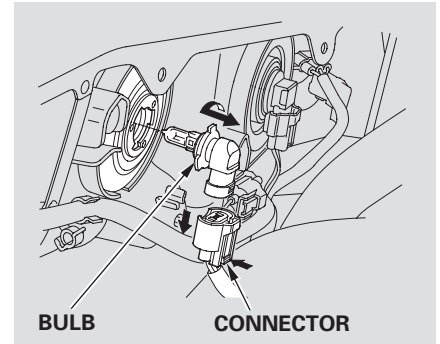

2. Remove the electrical connector from the bulb by squeezing the connector to unlock the tab, then slide the connector off the bulb.
3. Remove the bulb by turning it approximately one-quarter turn counterclockwise.

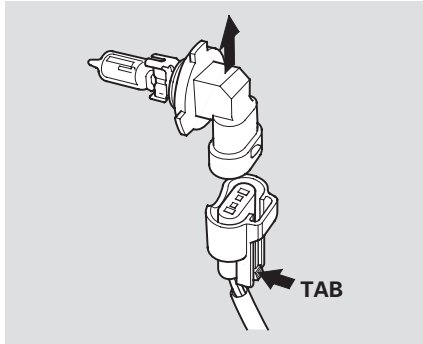

4. Insert the new bulb into the hole and turn it one-quarter turn clockwise to lock it in place.
5. Push the electrical connector onto the new bulb.
6. Turn on the headlights to test the new bulb.

Replacing Front Turn Signal/ Parking and Side Marker Light Bulbs

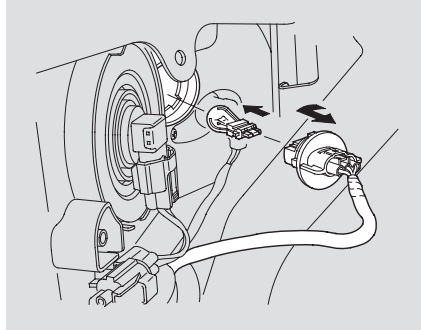

1. Remove the socket from the headlight assembly by turning it one-quarter turn counterclockwise.
2. To remove a bulb, pull it straight out of its socket.

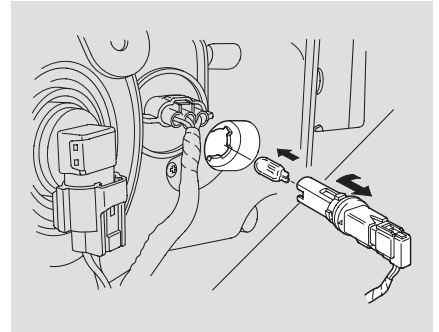

3. Install the new bulb into the socket.
4. Insert the socket back into the headlight assembly. Turn it clockwise to lock it in place.
5. Test the lights to make sure the new bulb is working.

CONTINUED

Lights

Replacing Rear Bulbs

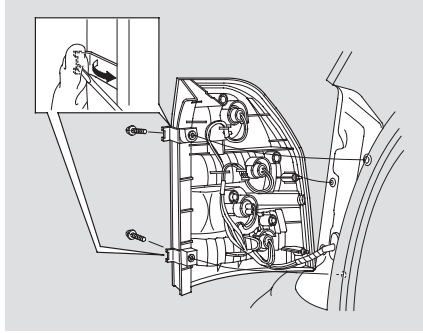

1. Open the tailgate. Use a screwdriver protected with a cloth to pry open the two covers.
2. Remove the two screws and remove the rear light assembly from the rear pillar.
3. Determine which of the four bulbs is burned out: brake/taillight, turn signal/hazard lights, side marker light, or back-up light.

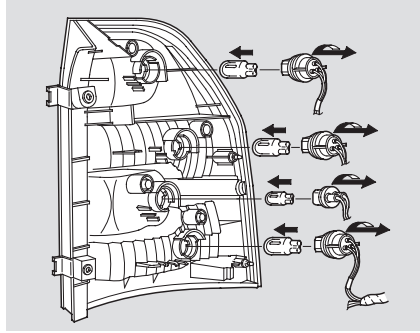

4. Remove the socket by turning it one-quarter turn counterclockwise.
5. Remove the burned-out bulb by pulling it straight out of the socket.

6. Install the new bulb into the socket.
7. Push the socket into the light assembly and turn it clockwise until it locks.
8. Test the lights to make sure the new bulb is working.
9. Install the rear light assembly in the body. Tighten the two screws. Snap the covers back into position.

Replacing a High-mount Brake Light Bulb

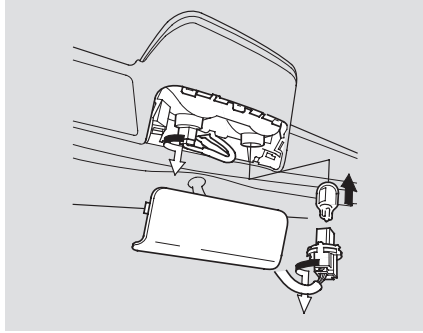

1. Remove the light assembly cover by prying carefully with a cloth-covered screwdriver in the notches along the top edge. Then pivot the cover out and down.
2. Remove the socket from the light assembly by turning it one-quarter turn counterclockwise.

3. Pull the bulb straight out of its socket.
Push the new bulb straight into the socket until it bottoms.
4. Test the lights to make sure the new bulb is working.
5. Put the socket back into the light assembly and turn it clockwise to lock it in place.
6. Place the cover back into the light assembly. Push it up until it locks in place.

Seat Belts, Floor Mats, Dust and Pollen Filter

Seat Belts

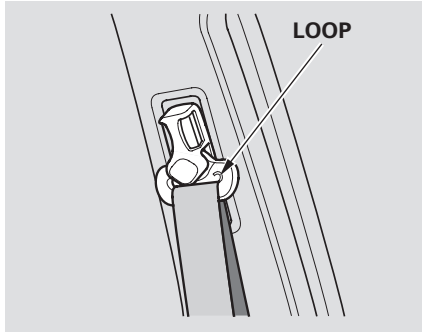

If your seat belts get dirty, use a soft brush with a mixture of mild soap and warm water to clean them. Do not use bleach, dye, or cleaning solvents. Let the belts air-dry before you use the vehicle.

Dirt build-up in the loops of the seat belt anchors can cause the belts to retract slowly. Wipe the insides of the loops with a clean cloth dampened in mild soap and warm water or isopropyl alcohol.

Floor Mats

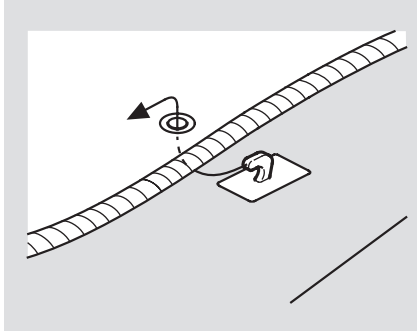

The driver's floor mat that came with your vehicle hooks over the floor mat anchor. This keeps the floor mat from sliding forward and possibly interfering with the pedals.

If you remove the driver's floor mat, make sure to re-anchor it when you put it back in your vehicle.

If you use a non-Acura floor mat, make sure it fits properly and that it can be used with the floor mat anchor. Do not put additional floor mats on top of the anchored mat.

Check the condition of the wiper blades at least every six months. Replace them if you find signs of cracking in the rubber, and areas that are getting hard, or if they leave streaks and unwiped areas when used.

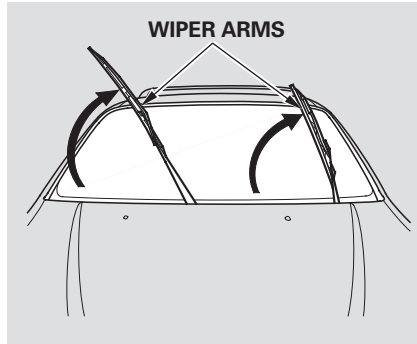

To replace a wiper blade:

1. Raise the wiper arm off the windshield.
Windshield: Raise the driver's side first, then the passenger's side.

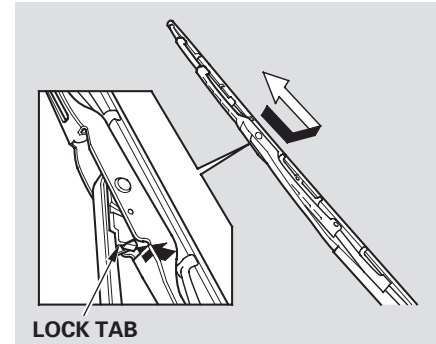

2. Front only:
Disconnect the blade assembly from the wiper arm by pushing in the lock tab. Hold the lock tab in while you push the blade assembly toward the base of the arm.

CONTINUED

Wiper Blades

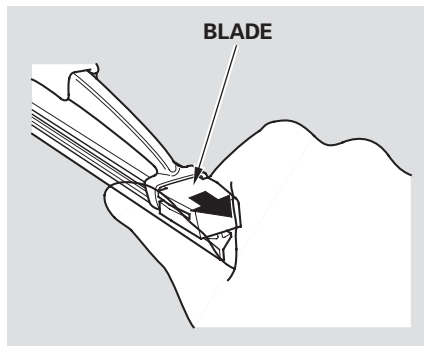

3. Remove the blade from its holder by grasping the tabbed end of the blade. Pull firmly until the tabs come out of the holder.

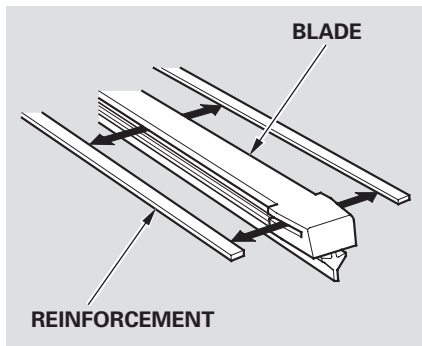

4. Examine the new wiper blades. If they have no plastic or metal reinforcement along the back edge, remove the metal reinforcement strips from the old wiper blade, and install them in the slots along the edge of the new blade.

5. Slide the new wiper blade into the holder until the tabs lock.
6. Front only:
Slide the wiper blade assembly onto the wiper arm. Make sure it locks in place.
7. Lower the wiper arm down against the window.
Windshield: Lower the passenger's side first, then the driver's side.