

# 2004 TSX Online Reference Owner's Manual

Use these links (and links throughout this manual) to navigate through this reference.  
For a printed owner's manual, click on authorized manuals or go to [www.helminc.com](http://www.helminc.com).

## Contents

---

### Owner's Identification Form

<b>Introduction</b> .....	<b>i</b>
<b>A Few Words About Safety</b> .....	<b>ii</b>
<b>Your Vehicle at a Glance</b> .....	<b>2</b>
<b>Driver and Passenger Safety</b> .....	<b>5</b>
Proper use and care of your vehicle's seat belts, and Supplemental Restraint System.	
<b>Instruments and Controls</b> .....	<b>57</b>
Instrument panel indicator and gauge, and how to use dashboard and steering column controls.	
<b>Comfort and Convenience Features</b> .....	<b>113</b>
How to operate the climate control system, the audio system, and other convenience features.	
<b>Before Driving</b> .....	<b>183</b>
What gasoline to use, how to break-in your new vehicle, and how to load luggage and other cargo.	
<b>Driving</b> .....	<b>197</b>
The proper way to start the engine, shift the transmission, and park, plus towing a trailer.	
<b>Maintenance</b> .....	<b>229</b>
The Maintenance Schedule shows you when you need to take your vehicle to the dealer.	
<b>Appearance Care</b> .....	<b>295</b>
Tips on cleaning and protecting your vehicle. Things to look for if your car ever needs body repairs.	
<b>Taking Care of the Unexpected</b> .....	<b>303</b>
This section covers several problems motorists sometimes experience, and how to handle them.	
<b>Technical Information</b> .....	<b>331</b>
ID numbers, dimensions, capacities, and technical information.	
<b>Warranty and Customer Relations (U.S. and Canada)</b> .....	<b>347</b>
A summary of the warranties covering your new Honda, and how to contact us.	
<b>Authorized Manuals (U.S. only)</b> .....	<b>351</b>
How to order manuals and other technical literature.	
<b>Index</b> .....	<b>I</b>

### Service Information Summary

A summary of information you need when you pull up to the fuel pump.

## Owner's Identification

---

OWNER \_\_\_\_\_  
\_\_\_\_\_

ADDRESS \_\_\_\_\_  
STREET

\_\_\_\_\_ CITY

STATE/PROVINCE

ZIP CODE/  
POSTAL CODE

V. I. N. \_\_\_\_\_

DELIVERY DATE \_\_\_\_\_  
(Date sold to original retail purchaser)

DEALER NAME \_\_\_\_\_ DEALER NO. \_\_\_\_\_

ADDRESS \_\_\_\_\_  
STREET

\_\_\_\_\_ CITY

STATE/PROVINCE

ZIP CODE/  
POSTAL CODE

OWNER'S SIGNATURE \_\_\_\_\_

DEALER'S SIGNATURE \_\_\_\_\_

This Owner's Manual should be considered a permanent part of the car, and should remain with the car when it is sold.

This Owner's Manual covers all models of the TSX. You may find descriptions of equipment and features that are not on your particular model.

The information and specifications included in this publication were in effect at the time of approval for printing. Honda Motor Co., Ltd. reserves the right, however, to discontinue or change specifications or design at any time without notice and without incurring any obligation whatsoever.

Congratulations! Your selection of a 2004 Acura TSX was a wise investment. It will give you years of driving pleasure.

One of the best ways to enhance the enjoyment of your new Acura is to read this manual. In it, you will learn how to operate its driving controls and convenience items. Afterwards, keep this owner's manual in your car so you can refer to it at any time.

Several warranties protect your new Acura. Read the warranty booklet thoroughly so you understand the coverages and are aware of your rights and responsibilities.

Maintaining your car according to the schedules given in this manual helps to keep your driving trouble-free while it preserves your investment. When your car needs maintenance, keep in mind that your Acura dealer's staff is specially trained in servicing the many systems unique to your Acura. Your Acura dealer is dedicated to your satisfaction and will be pleased to answer any questions and concerns.

### California Proposition 65 Warning

**WARNING:** This product contains or emits chemicals known to the State of California to cause cancer and birth defects or other reproductive harm.

As you read this manual, you will find information that is preceded by a **NOTICE** symbol. This information is intended to help you avoid damage to your Acura, other property, or the environment.

## A Few Words About Safety

---

Your safety, and the safety of others, is very important. And operating this car safely is an important responsibility.

To help you make informed decisions about safety, we have provided operating procedures and other information on labels and in this manual. This information alerts you to potential hazards that could hurt you or others.

Of course, it is not practical or possible to warn you about all the hazards associated with operating or maintaining your car. You must use your own good judgement.

You will find this important safety information in a variety of forms, including:

- **Safety Labels** — on the car.
- **Safety Messages** — preceded by a safety alert symbol  and one of three signal words: **DANGER**, **WARNING**, or **CAUTION**.  
These signal words mean:

 **DANGER**

You **WILL** be **KILLED** or **SERIOUSLY HURT** if you don't follow instructions.

 **WARNING**

You **CAN** be **KILLED** or **SERIOUSLY HURT** if you don't follow instructions.

 **CAUTION**

You **CAN** be **HURT** if you don't follow instructions.

- **Safety Headings** — such as Important Safety Reminders or Important Safety Precautions.
- **Safety Section** — such as Driver and Passenger Safety.
- **Instructions** — how to use this car correctly and safely.

This entire book is filled with important safety information — please read it carefully.

## Your Car at a Glance

---

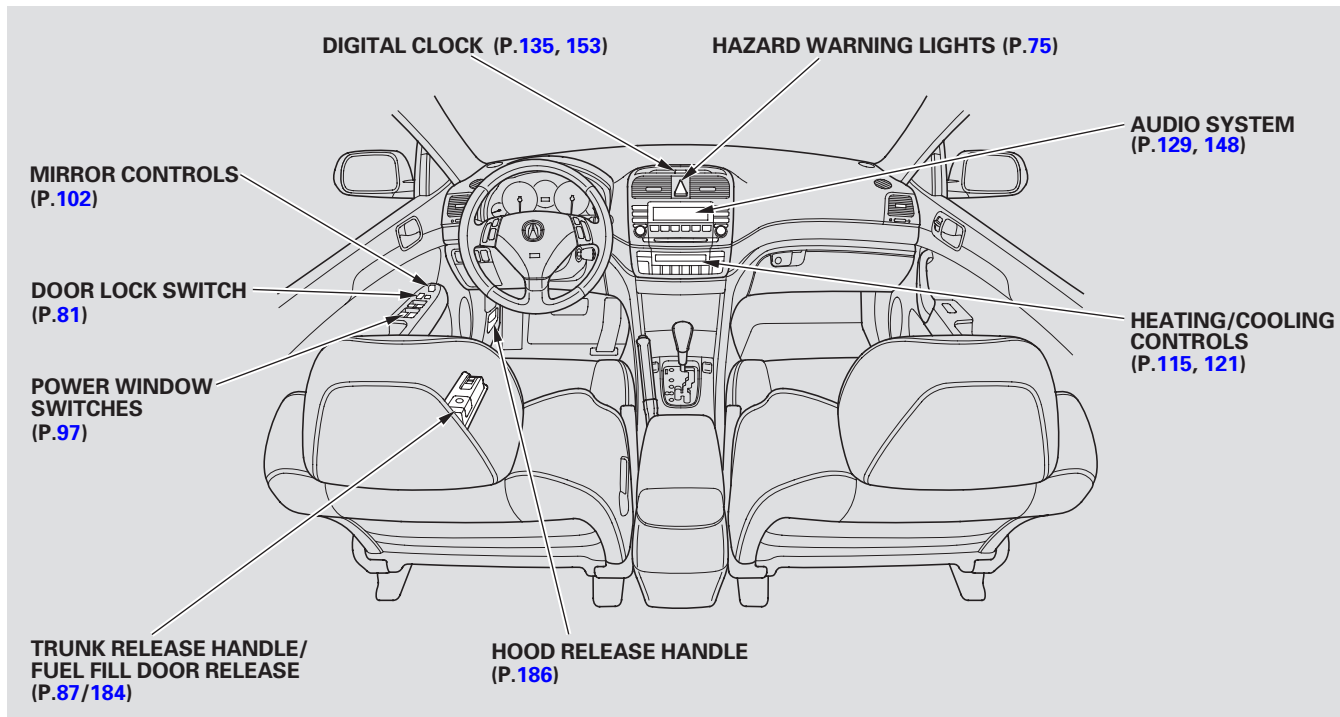

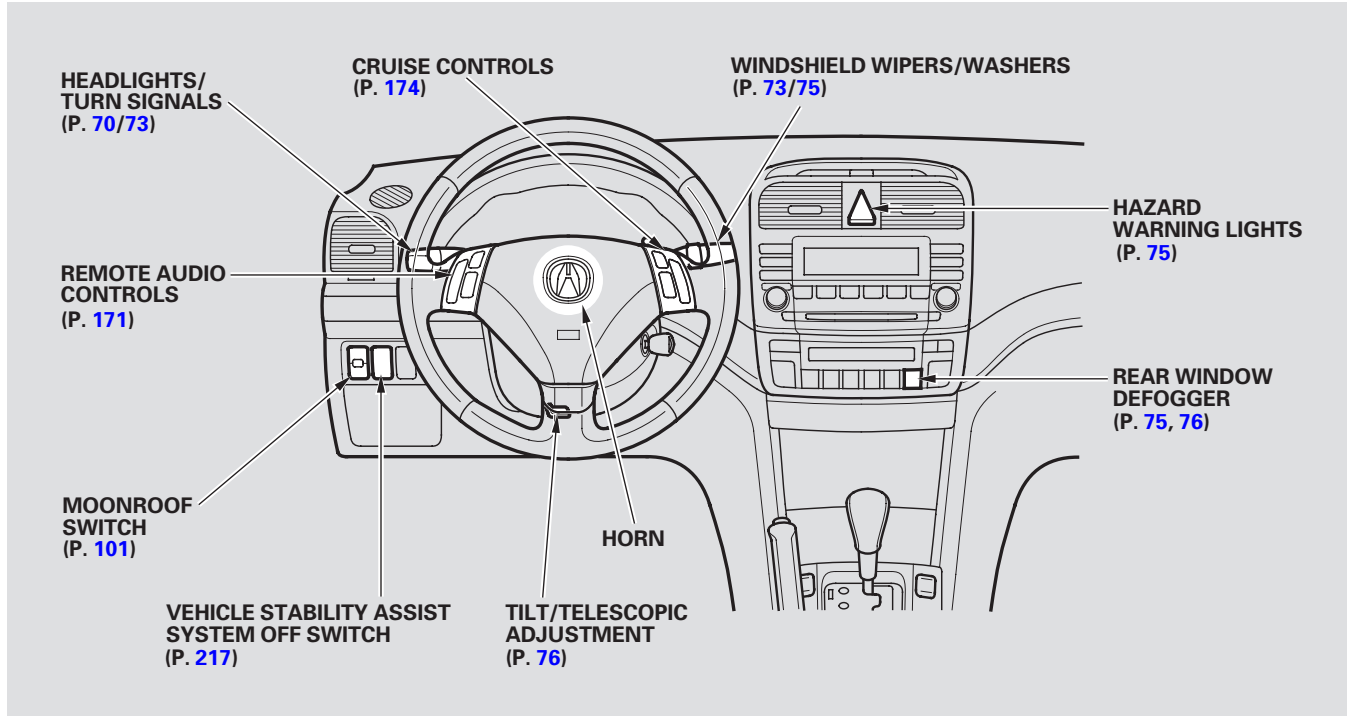



This section gives you important information about how to protect yourself and your passengers. It shows you how to use seat belts properly. It explains your Supplemental Restraint System. And it tells you how to properly restrain infants and children in your car.

Important Safety Precautions .....	6	3. Adjust the Seat-Backs .....	14	Protecting Larger Children .....	36
Your Car's Safety Features .....	7	4. Adjust the Head Restraints ....	15	Using Child Seats with	
Seat Belts .....	8	5. Fasten and Position the Seat		Tethers.....	39
Airbags .....	9	Belts .....	15	Using LATCH .....	41
Seats and Seat-Backs.....	10	6. Adjust the Steering Wheel ....	18	Additional Information About Your	
Head Restraints .....	11	7. Maintain a Proper Sitting		Seat Belts .....	43
Door Locks .....	11	Position .....	18	Seat Belt System Components...	43
Pre-Drive Safety Checklist .....	11	Advice for Pregnant Women.....	19	Lap/Shoulder Belt .....	43
Protecting Adults.....	12	Additional Safety Precautions....	20	Automatic Seat Belt	
1. Close and Lock the Doors .....	12	Protecting Children .....	21	Tensioners.....	44
2. Adjust the Front Seats .....	13	All Children Must Be		Seat Belt Maintenance .....	45
		Restrained .....	21	Additional Information About	
		Children Should Sit in the Back		Your Airbags .....	46
		Seat .....	22	SRS Components .....	46
		The Passenger's Front Airbag		How Your Front Airbags	
		Poses Serious Risks to		Work.....	46
		Children .....	22	How Your Side Airbags Work....	48
		If You Must Drive with Several		How Your Side Curtain	
		Children .....	24	Airbags Work .....	49
		If a Child Requires Close		How the SRS Indicator Works...	49
		Attention .....	25	How the Side Airbag Cutoff	
		Additional Safety Precautions....	25	Indicator Light Works .....	50
		General Guidelines for Using		Airbag Service .....	51
		Child Seats.....	26	Additional Safety Precautions....	52
		Protecting Infants .....	30	Carbon Monoxide Hazard .....	53
		Protecting Small Children .....	33	Safety Labels .....	54



## Important Safety Precautions

---

You'll find many safety recommendations throughout this section, and throughout this manual. The recommendations on this page are the ones we consider to be the most important.

### **Always Wear Your Seat Belt**

A seat belt is your best protection in all types of collisions. Airbags supplement seat belts, but airbags are designed to inflate only in a moderate to severe frontal collision. So even though your car is equipped with airbags, make sure you and your passengers always wear your seat belts, and wear them properly. (See page [15](#).)

### **Restrain All Children**

Children are safest when they are properly restrained in the back seat, not the front seat. A child who is too small for a seat belt must be properly restrained in a child safety seat. (See page [21](#).)

### **Be Aware of Airbag Hazards**

While airbags can save lives, they can cause serious or fatal injuries to occupants who sit too close to them, or are not properly restrained. Infants, young children, and short adults are at the greatest risk. Be sure to follow all instructions and warnings in this manual. (See page [9](#).)

### **Don't Drink and Drive**

Alcohol and driving don't mix. Even one drink can reduce your ability to respond to changing conditions, and your reaction time gets worse with every additional drink. So don't drink and drive, and don't let your friends drink and drive, either.

### **Control Your Speed**

Excessive speed is a major factor in crash injuries and deaths. Generally, the higher the speed the greater the risk, but serious accidents can also occur at lower speeds. Never drive faster than is safe for current conditions, regardless of the maximum speed posted.

### **Keep Your Car in Safe Condition**

Having a tire blowout or a mechanical failure can be extremely hazardous. To reduce the possibility of such problems, check your tire pressures and condition frequently, and perform all regularly scheduled maintenance. (See page [232](#).)

## Your Car's Safety Features

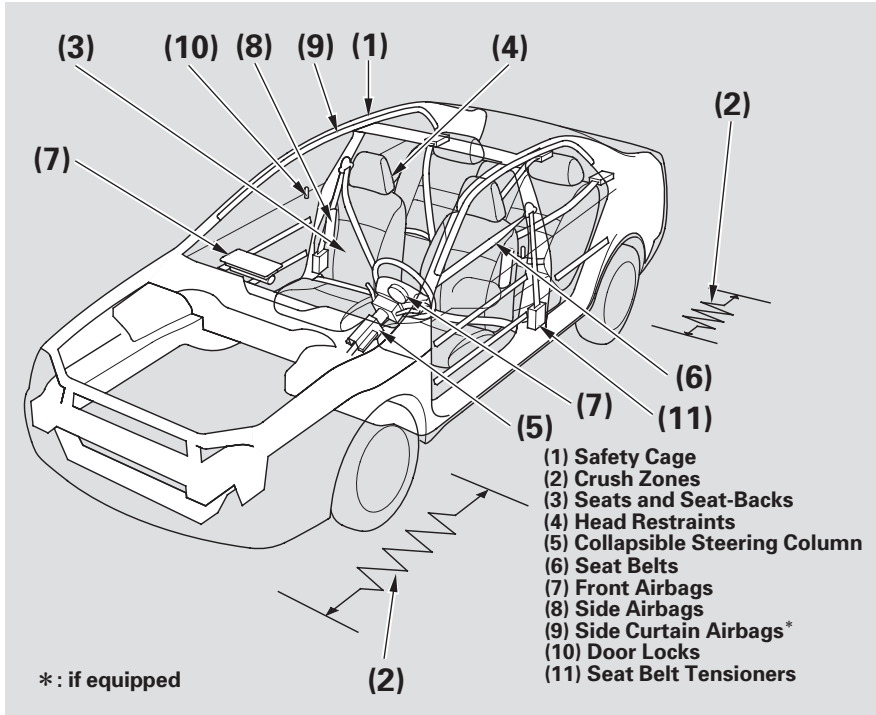

Your car is equipped with many features that work together to protect you and your passengers during a crash.

Some safety features do not require any action on your part. These include a strong steel framework that forms a safety cage around the passenger compartment; front and rear crush zones that are designed to crumple and absorb energy during a crash; a collapsible steering column; and seat belt tensioners that automatically tighten the front seat belts in the event of a crash.

*CONTINUED*

## Your Car's Safety Features

---

These safety features are designed to reduce the severity of injuries in a crash. However, you and your passengers can't take full advantage of these safety features unless you remain sitting in a proper position and ***always wear your seat belts properly***. In fact, some safety features can contribute to injuries if they are not used properly.

### Seat Belts

For your safety, and the safety of your passengers, your car is equipped with seat belts in all seating positions.



Your seat belt system also includes a light on the instrument panel to remind you and your passengers to fasten your seat belts.

### Why Wear Seat Belts

Seat belts are the single most effective safety device for adults and larger children. (Infants and smaller children must be properly restrained in child seats.)

Not wearing a seat belt properly increases the chance of serious injury or death in a crash, even though your car has airbags.

In addition, most states and all Canadian provinces require you to wear seat belts.

### **⚠ WARNING**

Not wearing a seat belt properly increases the chance of serious injury or death in a crash, even if you have airbags.

Be sure you and your passengers always wear seat belts and wear them properly.

When properly worn, seat belts:

- Keep you connected to the car so you can take advantage of the car's built-in safety features.
- Help protect you in almost every type of crash, including frontal, side, and rear impacts and rollovers.

- Help keep you from being thrown against the inside of the car and against other occupants.
- Keep you from being thrown out of the car.
- Help keep you in a good position should the airbags ever deploy. A good position reduces the risk of injury from an inflating airbag, and allows you to get the best advantage from the airbag.

Of course, seat belts cannot completely protect you in every crash. But in most cases, seat belts can reduce your risk of serious injury.

**What you should do:** Always wear your seat belt, and make sure you wear it properly.

### Airbags

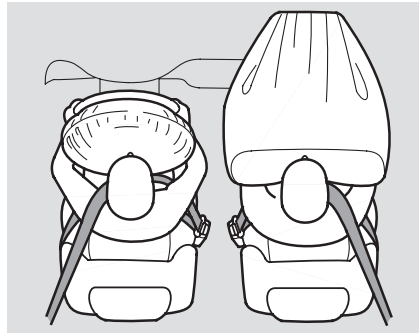

Your car has a Supplemental Restraint System (SRS) with dual-stage, dual-threshold front airbags to help protect the heads and chests of the driver and a front seat passenger during a moderate to severe frontal collision.

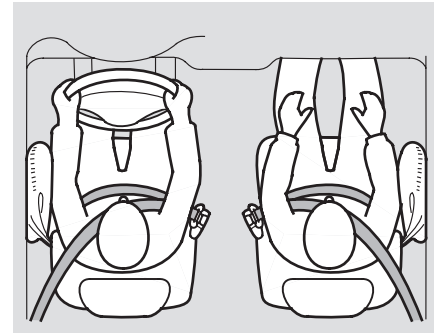

Your car also has side airbags to help protect the upper torso of the driver or a front seat passenger during a moderate to severe side impact.

*CONTINUED*

## Your Car's Safety Features

---

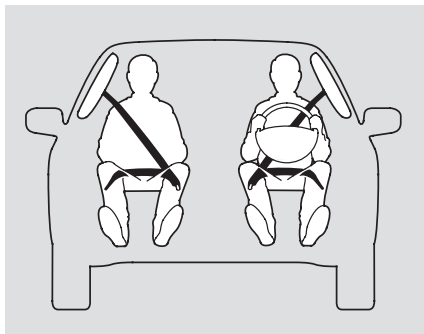

Your car also has side curtain airbags. During a moderate to severe side impact, side curtain airbags help to protect the heads of the driver, front seat passenger, and passengers sitting in the outer rear seating positions.

The most important things you need to know about your airbags are:

- ***Airbags do not replace seat belts.*** They are designed to supplement the seat belts.
- ***Airbags offer no protection in rear impacts, rollovers, or minor frontal or side collisions.***
- ***Airbags can pose serious hazards.*** To do their job, airbags must inflate with tremendous force and speed. So while airbags help save lives, they can cause minor injuries, or more serious or even fatal injuries if occupants are not properly restrained or sitting properly.

***What you should do:*** Always wear your seat belt properly, and sit upright and as far back as possible from the steering wheel or dashboard.

### **Seats and Seat-Backs**

Your car's seats are designed to keep you in a comfortable, upright position so you can take full advantage of the protection offered by seat belts and the energy absorbing materials in the seats.

How you adjust your seats and seat-backs can also affect your safety. For example, sitting too close to the steering wheel or dashboard increases the risk of you or your passenger being injured by striking the inside of the car, or by an inflating airbag.

Reclining a seat-back too far reduces the seat belt's effectiveness and increases the chance that the seat's occupant will slide under the seat belt in a crash and be seriously injured.

**What you should do:** Move the front seats as far back as possible, and keep adjustable seat-backs in an upright position whenever the car is moving.

### Head Restraints

Head restraints can help protect you from whiplash and other injuries. For maximum protection, the back of your head should rest against the center of the head restraint.

### Door Locks

Keeping your doors locked reduces the chance of being thrown out of the car during a crash. It also helps prevent occupants from accidentally opening a door and falling out, and outsiders from unexpectedly opening your doors.

### Pre-Drive Safety Checklist

To make sure you and your passengers get the maximum protection from your car's safety features, check the following each time before you drive away:

- All adults, and children who have outgrown child safety seats, are wearing their seat belts and wearing them properly (see page [15](#)).
- Any infant or small child is properly restrained in a child seat in the back seat (see page [21](#)).
- Front seat occupants are sitting upright and as far back as possible from the steering wheel and dashboard (see page [13](#)).
- Seat-backs are upright (see page [14](#)).
- Head restraints are properly adjusted (see page [15](#)).
- All doors are closed and locked (see page [12](#)).
- All cargo is properly stored or secured (see page [193](#)).

## Protecting Adults

---

The rest of this section gives more detailed information about how you can maximize your safety.

Remember, however, that no safety system can prevent all injuries or deaths that can occur in severe crashes, even when seat belts are properly worn and the airbags deploy.

### Introduction

The following pages provide instructions on how to properly protect the driver and other adult occupants.

These instructions also apply to children who have outgrown child seats and are large enough to wear lap/shoulder belts. (See page 36 for important additional guidelines on how to properly protect larger children.)

### 1. Close and Lock the Doors

After everyone has entered the car, be sure the doors are closed and locked.

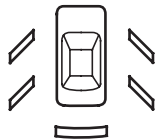

Your car has a door monitor light on the instrument panel to indicate when a specific door is not tightly closed.

For safety, locking the doors reduces the chance that a passenger, especially a child, will open a door while the car is moving and accidentally fall out. It also reduces the chance of someone being thrown out of the car during a crash.

For security, locked doors can prevent an outsider from unexpectedly opening a door when you come to a stop.

See page 81 for how to lock the doors.

### 2. Adjust the Front Seats

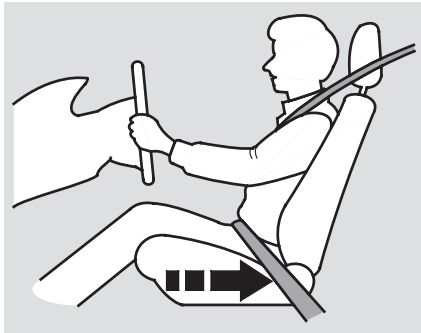

Any driver who sits too close to the steering wheel is at risk of being seriously injured or killed by striking the steering wheel or from being struck by an inflating front airbag during a crash.

To reduce the chance of injury, wear your seat belt properly, sit upright with your back against the seat, and move the seat away from the steering wheel to the farthest distance that allows you to maintain full control of the car.

The National Highway Traffic Safety Administration and Transport Canada recommend that drivers adjust the seat so the center of the chest is at least 10 inches (25cm) away from the center of the steering wheel. In addition to adjusting the seat, you can adjust the steering wheel in and out (see page 76).

Also make sure your front seat passenger moves the seat as far to the rear as possible.

### **⚠ WARNING**

Sitting too close to a front airbag can result in serious injury or death if the front airbags inflate.

Always sit as far back from the front airbags as possible.

Most shorter drivers can get far enough away from the steering wheel and still reach the pedals. However, if you are concerned about sitting too close, we recommend that you investigate whether some type of adaptive equipment may help.

Once your seat is adjusted correctly, rock it back and forth to make sure the seat is locked in position.

See page 90 for how to adjust the front seats.



## Protecting Adults

### 3. Adjust the Seat-Backs

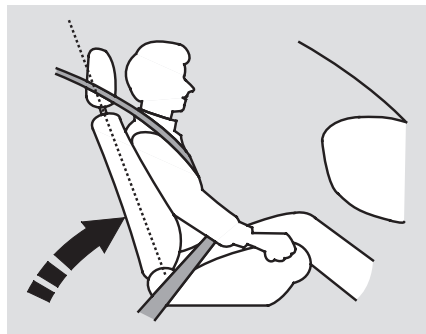

Adjust the driver's seat-back to a comfortable, upright position, leaving ample space between your chest and the airbag cover in the center of the steering wheel. If you sit too close to the steering wheel, you could be injured if the front airbag inflates.

A front passenger should also adjust the seat-back to an upright position, but as far from the dashboard as possible. A passenger who sits too close to the dashboard could be injured if the front airbag inflates.

Reclining a seat-back so that the shoulder part of the belt no longer rests against the occupant's chest reduces the protective capability of the belt. It also increases the chance of sliding under the belt in a crash and being seriously injured. The farther a seat-back is reclined, the greater the risk of injury.

### **⚠ WARNING**

Reclining the seat-back too far can result in serious injury or death in a crash.

Adjust the seat-back to an upright position and sit well back in the seat.

See page [91](#) for how to adjust seat-backs.

### 4. Adjust the Head Restraints

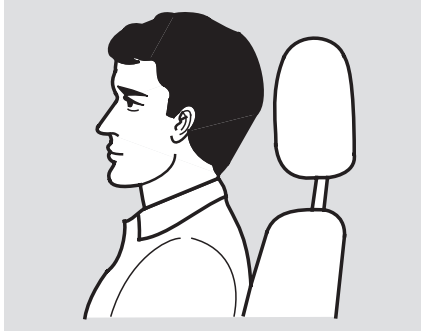

Before driving, make sure everyone with an adjustable head restraint has properly positioned the head restraint. The restraint should be positioned so the back of the occupant's head rests against the center of the restraint. A taller person should adjust the restraint as high as possible.

### **⚠ WARNING**

Improperly positioning head restraints reduces their effectiveness and you can be seriously injured in a crash.

Make sure head restraints are in place and positioned properly before driving.

Properly adjusted head restraints will help protect occupants from whiplash and other crash injuries.

See page [93](#) for how to adjust the head restraints.

### 5. Fasten and Position the Seat Belts

Insert the latch plate into the buckle, then tug on the belt to make sure the belt is securely latched. Also check that the belt is not twisted, because a twisted belt can cause serious injuries in a crash.

*CONTINUED*

## Protecting Adults

---



Position the lap part of the belt as low as possible across your hips, then pull up on the shoulder part of the belt so the lap part fits snugly. This lets your strong pelvic bones take the force of a crash and reduces the chance of internal injuries.

If necessary, pull up on the belt again to remove any slack from the shoulder part, then check that the belt rests across the center of your chest and over your shoulder. This spreads the forces of a crash over the strongest bones in your upper body.

### **⚠ WARNING**

Improperly positioning the seat belts can cause serious injury or death in a crash.

Make sure all seat belts are properly positioned before driving.

If the seat belt touches or crosses your neck, or if it crosses your arm instead of your shoulder, you need to adjust the seat belt anchor height.

### RELEASE BUTTONS

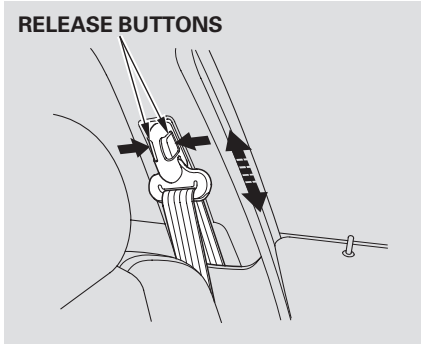

To adjust the height of a front seat belt anchor, squeeze the two release buttons and slide the anchor up or down as needed (it has four positions).

*Never place the shoulder portion of a lap/shoulder belt under your arm or behind your back.* This could cause very serious injuries in a crash.

If a seat belt does not seem to work as it should, it may not protect the occupant in a crash. ***No one should sit in a seat with an inoperative seat belt.*** Anyone using a seat belt that is not working properly can be seriously injured or killed. Have your Acura dealer check the belt as soon as possible.

See page [43](#) for additional information about your seat belt system and how to take care of your belts.

## Protecting Adults

### 6. Adjust the Steering Wheel

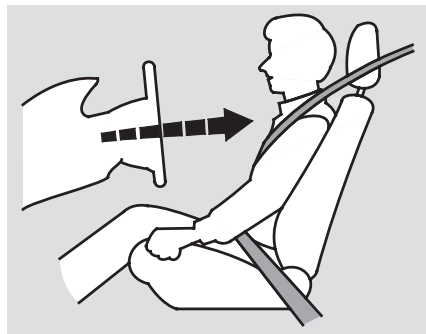

Adjust the steering wheel, if needed, so that the wheel points toward your chest, not toward your face.

Pointing the steering wheel toward your chest provides optimal protection from the airbag.

See page [76](#) for how to adjust the steering wheel.

### 7. Maintain a Proper Sitting Position

After all occupants have adjusted their seats and put on seat belts, it is very important that they continue to sit upright, well back in their seats, with their feet on the floor, until the car is parked and the engine is off.

Sitting improperly can increase the chance of injury during a crash. For example, if an occupant slouches, lies down, turns sideways, sits forward, leans forward or sideways, or puts one or both feet up, the chance of injury during a crash is greatly increased.

In addition, an occupant who is out of position in the front seat can be seriously or fatally injured by striking interior parts of the car, or by being struck by an inflating front airbag. Being struck by an inflating side airbag can result in possibly serious injuries.

#### **⚠ WARNING**

Sitting improperly or out of position can result in serious injury or death in a crash.

Always sit upright, well back in the seat, with your feet on the floor.

Remember, to get the best protection from your car's airbags and other safety features, you must sit properly and wear your seat belt properly.

### Advice for Pregnant Women



Because protecting the mother is the best way to protect her unborn child, a pregnant woman should always wear a seat belt whenever she drives or rides in a car.

Remember to keep the lap portion of the belt as low as possible across your hips.

Pregnant women should also sit upright and as far back as possible from the steering wheel or dashboard. This will reduce the risk of injuries to both the mother and her unborn child that can be caused by a crash or an inflating airbag.

Each time you have a check-up, ask your doctor if it's okay for you to drive.

## Protecting Adults

---

### Additional Safety Precautions

- **Two people should never use the same seat belt.** If they do, they could be very seriously injured in a crash.
- **Do not put any accessories on seat belts.** Devices intended to improve occupant comfort or reposition the shoulder part of a seat belt can severely compromise the protective capability of the seat belt and increase the chance of serious injury in a crash.
- **Do not place hard or sharp objects between yourself and a front airbag.** Carrying hard or sharp objects on your lap, or driving with a pipe or other sharp objects in your mouth, can result in injuries if your front airbag inflates.
- **Do not attach or place objects on the front airbag covers.** Any object attached to or placed on the covers marked “SRS AIRBAG” in the center of the steering wheel and on top of the dashboard could interfere with the proper operation of the airbags. Or, if the airbags inflate, the objects could be propelled inside the car and hurt someone.
- **On models with side airbags or side curtain airbags, do not attach hard objects on or near a front door.** If a side airbag or a side curtain airbag inflates, a cup holder or other hard object attached on or near the door could be propelled inside the car and hurt someone.
- **Keep your hands and arms away from the airbag covers.** If your hands or arms are close to the airbag cover in the center of the steering wheel or on top of the dashboard, they could be injured if the front airbag inflates.

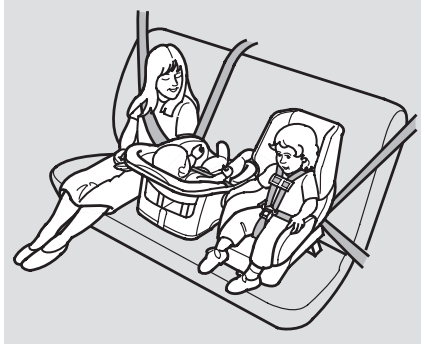

Children depend on adults to protect them. However, despite their best intentions, many parents and other adults may not know how to *properly* protect young passengers.

So if you have children, or if you ever need to drive with a grandchild or other children in your car, be sure to read this section.

### **⚠ WARNING**

Children who are unrestrained or improperly restrained can be seriously injured or killed in a crash.

Any child too small for a seat belt should be properly restrained in a child seat. A larger child should be properly restrained with a seat belt.

**All Children Must Be Restrained**  
Each year, many children are injured or killed in car crashes because they are either unrestrained or not properly restrained. In fact, car accidents are the number one cause of death of children ages 12 and under.

To reduce the number of child deaths and injuries, every state and Canadian province requires that infants and children be restrained whenever they ride in a car.

***Any child who is too small to wear a seat belt should be properly restrained in a child seat.*** (See page [26](#).)

***A larger child should always be restrained with a seat belt, and use a booster, if needed.*** (See page [36](#).)

CONTINUED



## Protecting Children

---

### *Additional Precautions to Parents*

- ***Never hold an infant or child on your lap.*** If you are not wearing a seat belt in a crash, you could be thrown forward into the dashboard and crush the child.

If you are wearing a seat belt, the child can be torn from your arms during a crash. For example, if your car crashes into a parked car at 30 mph (48 km/h), a 20-lb (9 kg) infant will become a 600-lb (275 kg) force, and you will not be able to hold on.

- ***Never put a seat belt over yourself and an infant or child.*** During a crash, the belt could press deep into the child and cause very serious injuries.

### **Children Should Sit in the Back Seat**

According to accident statistics, children of all ages and sizes are safer when they are restrained in the back seat, not the front seat. The National Highway Traffic Safety Administration and Transport Canada recommend that all children ages 12 and under be properly restrained in the back seat.

In the back seat, children are less likely to be injured by striking hard interior parts during a collision or hard braking. Also, children cannot be injured by an inflating airbag when they ride in the back.

### **The Passenger's Front Airbag Poses Serious Risks to Children**

Front airbags have been designed to help protect adults in a moderate to severe frontal collision. To do this, the passenger's front airbag is quite large, and it inflates with tremendous speed.

#### ***Infants***

***Never put a rear-facing child seat in the front seat of a car equipped with a passenger's front airbag.*** If the airbag inflates, it can hit the back of the child seat with enough force to kill or very seriously injure an infant.

### ***Small Children***

***Placing a forward-facing child seat in the front seat of a car equipped with a passenger's front airbag can be hazardous.*** If the vehicle seat is too far forward, or the child's head is thrown forward during a collision, an inflating front airbag can strike the child with enough force to kill or very seriously injure a small child.

### ***Larger Children***

***Children who have outgrown child seats are also at risk of being injured or killed by an inflating passenger's front airbag.*** Whenever possible, larger children should sit in the back seat, in a booster seat if needed, and be properly restrained with a seat belt. (See page 36 for important information about protecting larger children.)

### ***U.S. Models***

To remind you of the passenger's front airbag hazards, and that children must be properly restrained in the back seat, your car has warning labels on the dashboard and on the driver's and front passenger's visors. Please read and follow the instructions on these labels.



*CONTINUED*

# Protecting Children

---

## *Canadian Models*

To remind you of the front airbag hazards, your car has warning labels on the driver's and front passenger's visors. Please read and follow the instructions on these labels.

### **CAUTION**

TO AVOID SERIOUS INJURY:

- FOR MAXIMUM SAFETY PROTECTION IN ALL TYPES OF CRASHES, YOU MUST ALWAYS WEAR YOUR SAFETY BELT.
- DO NOT INSTALL REARWARD-FACING CHILD SEATS IN ANY FRONT PASSENGER SEAT POSITION.
- DO NOT SIT OR LEAN UNNECESSARILY CLOSE TO THE AIR BAG.
- DO NOT PLACE ANY OBJECTS OVER THE AIR BAG OR BETWEEN THE AIR BAG AND YOURSELF.
- SEE THE OWNER'S MANUAL FOR FURTHER INFORMATION AND EXPLANATIONS.

### **PRÉCAUTION:**

POUR ÉVITER DES BLESSURES GRAVES:

- POUR PROFITER D'UNE PROTECTION MAXIMALE LORS D'UNE COLLISION BOUCLEZ TOUJOURS VOTRE CEINTURE DE SÉCURITÉ.
- N'INSTALLEZ JAMAIS UN SIÈGE POUR ENFANTS FAISANT FACE À L'ARRIÈRE SUR LE SIÈGE DU PASSAGER AVANT.
- NE VOUS APPUYEZ PAS ET NE VOUS ASSEYEZ PAS PRES DU COUSSIN GONFLABLE.
- NE DEPOSEZ AUCUN OBJET SUR LE COUSSIN GONFLABLE OU ENTRE LE COUSSIN GONFLABLE ET VOUS.
- LISEZ LE GUIDE UTILISATEUR POUR DE PLUS AMPLES RENSEIGNEMENTS.

## **If You Must Drive with Several Children**

Your car has three seating positions in the back seat where children can be properly restrained.

If you ever have to carry more than three children in your car:

- Place the largest child in the front seat, provided the child is large enough to wear a seat belt properly (see page [36](#)).
- Move the vehicle seat as far to the rear as possible (see page [13](#)).
- Have the child sit upright and well back in the seat (see page [18](#)).
- Make sure the seat belt is properly positioned and secured (see page [15](#)).

### **If a Child Requires Close Attention**

Many parents say they prefer to put an infant or small child in the front passenger seat so they can watch the child, or because the child requires attention.

Placing a child in the front seat exposes the child to hazards from the passenger's front airbag, and paying close attention to a child distracts the driver from the important tasks of driving, placing both of you at risk.

If a child requires physical attention or frequent visual contact, we strongly recommend that another adult ride with the child in the back seat. The back seat is far safer for a child than the front.

### **Additional Safety Precautions**

- ***Use childproof door locks to prevent children from opening the doors.*** Using this feature will prevent children from opening the doors and accidentally falling out (see page [87](#) ).
- ***Use the main power window switch to prevent children from opening the rear windows.*** Using this feature will prevent children from playing with the windows, which could expose them to hazards or distract the driver (see page [97](#) ).
- ***Do not leave children alone in your car.*** Leaving children without adult supervision is illegal in most states and Canadian provinces, and can be very hazardous. For example, infants and small children left in a car on a hot day can die from heatstroke. And children left alone with the key in the ignition can accidentally set the car in motion, possibly injuring themselves or others.

*CONTINUED*

## Protecting Children

---

- **Lock all doors and the trunk when your car is not in use.** Children who play in cars can accidentally get trapped inside the trunk and be seriously injured or could die. Teach your children not to play in or around cars. Know how to operate the emergency trunk opener and decide if your children should be shown how to use this feature (see page 88).
- **Keep car keys/remote transmitters out of the reach of children.** Even very young children learn how to unlock car doors, turn on the ignition, and open the trunk, which can lead to accidental injury or death.

### General Guidelines for Using Child Seats

The following pages give general guidelines for selecting and installing child seats for infants and small children.

#### *Selecting a Child Seat*

To provide proper protection, a child seat should meet three requirements:

- 1. The child seat should meet safety standards.** The child seat should meet Federal Motor Vehicle Safety Standard 213 (FMVSS 213) or Canadian Motor Vehicle Safety Standard 213 (CMVSS 213). Look for the manufacturer's statement of compliance on the box and seat.
- 2. The child seat should be of the proper type and size to fit the child.**

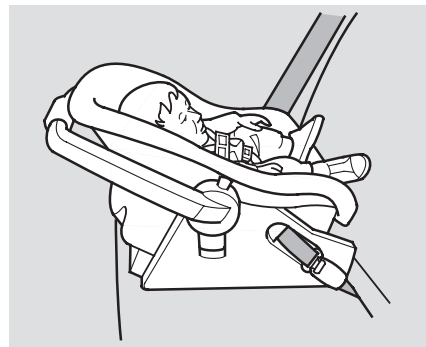

**Infants:** Children up to about one year old should be restrained in a rear-facing, reclining child seat. Only a rear-facing seat provides the proper support to protect an infant's head, neck, and back. See page 30 for additional information on protecting infants.

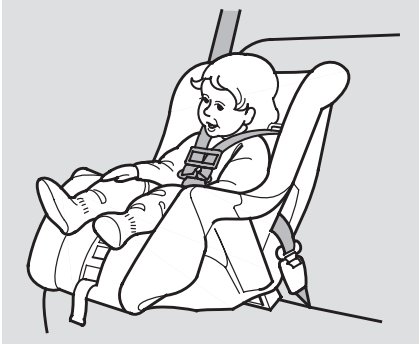

**Small Children:** A child who is too large for a rear-facing child seat, and who can sit up without support, should be restrained in a forward-facing child seat. See page 33 for additional information on protecting small children.

***3. The child seat should fit the vehicle seating position (or positions) where it will be used.***

Due to variations in the design of child seats, vehicle seats, and seat belts, all child seats will not fit all vehicle seating positions.

However, Acura is confident that one or more child seat models can fit and be properly installed in all recommended seating positions in your car.

Before purchasing a child seat, we recommend that parents test the child seat in the specific vehicle seating position (or positions) where they intend to use the seat. If a previously purchased child seat does not fit, you may need to buy a different one that will fit.

Your car has lower anchors installed for use with LATCH (Lower Anchors and Tethers for Children) - compatible child seats. For more information, see page 41 .

*CONTINUED*

## Protecting Children

### *Placing a Child Seat*

This page briefly summarizes Honda's recommendations on where to place rear-facing and forward-facing child seats in your car.

#### **Airbags Pose Serious Risks to Children**

The passenger's front airbag inflates with enough force to kill or seriously injure an infant in a rear-facing child seat.

A small child in a forward-facing child seat is also at risk. If the car seat is too far forward, or the child's head is thrown forward during a collision, an inflating front airbag can kill or seriously injure the child.

If a small child must ride in the front, follow the instructions provided in this section.

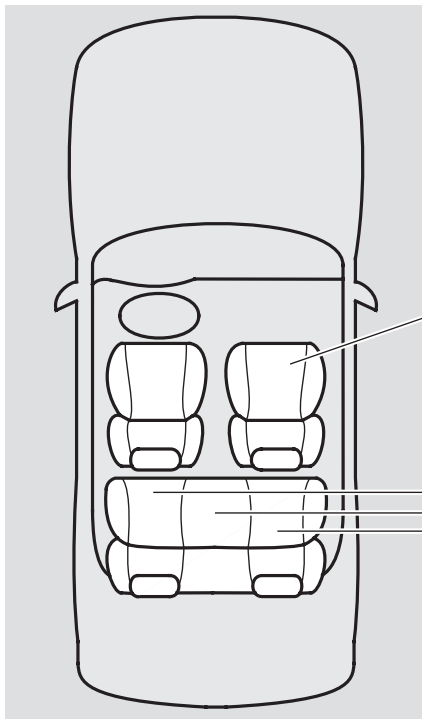

#### **Front Passenger's Seat**

**Infants:** Never in the front seat, due to the front airbag hazard.

**Small children:** Not recommended, due to the front airbag hazard. If a small child must ride in front, move the vehicle seat to the rear-most position and secure a front-facing child seat with the seat belt. (see page [34](#)).

#### **Back Seats**

**Infants:** Recommended positions. Properly secure a rear-facing child seat (see pages [31](#) and [41](#)).

**Small children:** Recommended positions. Properly secure a front-facing child seat (see pages [34](#) and [41](#)).

### ***Installing a Child Seat***

After selecting a proper child seat, and a good position to install the seat, there are three main steps in installing the seat:

**1. Properly secure the child seat to the car.** All child seats are designed to be secured to the car with the lap part of a lap/shoulder belt. Some child seats can be secured to the car's LATCH anchorage system instead. A child whose seat is not properly secured to the car can be endangered in a crash. See pages 31, 34 and 41 for instructions on how to properly secure child seats in this car.

**2. Make sure the child seat is firmly secured.** After installing a child seat, push and pull the seat forward and from side to side to verify that it is secure.

To provide security during normal driving maneuvers as well as during a collision, we recommend that parents secure a child seat as firmly as possible.

However, a child seat does not need to be "rock solid." In some cars or seating positions, it may be difficult to install a child seat so that it does not move at all. Some side-to-side or back-and-forth movement can be expected and should not reduce the child seat's effectiveness.

If the child seat is not secure, try installing it in a different seating position, or use a different style of child seat that can be firmly secured in the desired seating position.

**3. Secure the child in the child seat.** Make sure the child is properly strapped in the child seat according to the child seat maker's instructions. A child who is not properly secured in a child seat can be thrown out of the seat in a crash and be seriously injured.

### ***Storing a Child Seat***

When you are not using a child seat, either remove it and store it in a safe place, or make sure it is properly secured. An unsecured child seat can be thrown around the car during a crash or sudden stop and injure someone.



# Protecting Children

## Protecting Infants



### ***Child Seat Type***

Only a rear-facing child seat provides proper support for a baby's head, neck, and back. Infants up to about one year of age must be restrained in a rear-facing child seat.

Two types of seats may be used: a seat designed exclusively for infants, or a convertible seat used in the rear-facing, reclining mode.

## **⚠ WARNING**

Placing a rear-facing child seat in the front seat can result in serious injury or death if the passenger's front airbag inflates.

Always place a rear-facing child seat in the back seat, not the front.

We recommend that an infant be restrained in a rear-facing child seat until the infant is at least one year old, reaches the seat maker's weight or height limit, and is able to sit up without support.

### ***Rear-Facing Child Seat Placement***

In this car, a rear-facing child seat can be placed in any seating position in the back seat, but not in the front seat.

### ***Never put a rear-facing child seat in***

***the front seat.*** If the passenger's front airbag inflates, it can hit the back of the child seat with enough force to kill or seriously injure an infant. If an infant must be closely watched, we recommend that another adult sit in the back seat with the baby.

### ***Do not put a rear-facing child seat in***

***a forward-facing position.*** If placed facing forward, an infant could be very seriously injured during a frontal collision.

When properly installed, a rear-facing child seat may prevent the driver or a front-seat passenger from moving the seat as far back as recommended (see page 13). Or it may prevent them from locking the seat-back in the desired upright position (see page 14).

In either case, we recommend that you place the child seat directly behind the front passenger seat, move the front seat as far forward as needed, and leave it unoccupied. Or you may wish to get a smaller child seat that allows you to safely carry a front passenger.

### ***Rear-Facing Child Seat Installation***

The lap/shoulder belts in the back seats have a locking mechanism that must be activated to secure a child seat.

The following pages provide instructions and tips on how to secure a rear-facing child seat with this type of seat belt.

If you have a child seat designed to attach to the car's LATCH anchorage system, follow the instructions on page 41.

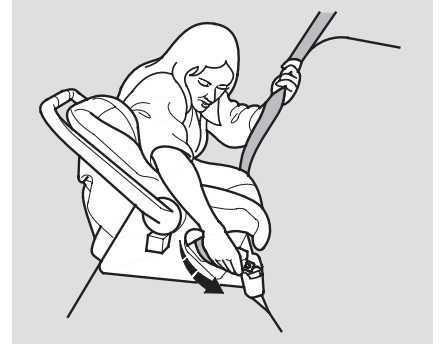

1. With the child seat in the desired back seating position, route the belt through the child seat according to the seat maker's instructions, then insert the latch plate into the buckle.

*CONTINUED*

## Protecting Children

---

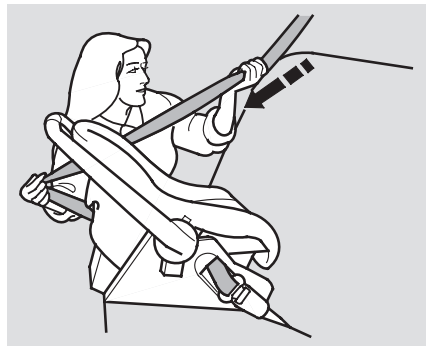

2. To activate the lockable retractor, slowly pull the shoulder part of the belt all the way out until it stops, then let the belt feed back into the retractor.
3. After the belt has retracted, tug on it. If the belt is locked, you will not be able to pull it out. If you can pull the belt out, it is not locked and you will need to repeat these steps.

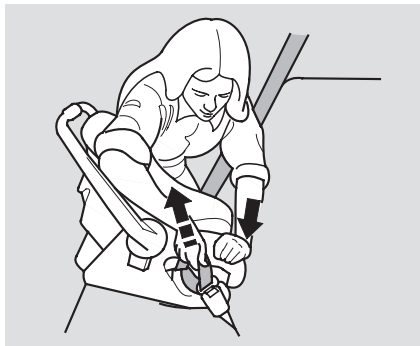

4. After confirming that the belt is locked, grab the shoulder part of the belt near the buckle and pull up to remove any slack from the lap part of the belt. Remember, if the lap part of the belt is not tight, the child seat will not be secure. To remove slack, it may help to put weight on the child seat, or push on the back of the seat, while pulling up on the belt.



5. Push and pull the child seat forward and from side to side to verify that it is secure enough to stay upright during normal driving maneuvers. If the child seat is not secure, unlatch the belt, allow it to retract fully, then repeat these steps.

To deactivate the locking mechanism and remove a child seat, unlatch the buckle, unrout the seat belt, and let the belt fully retract.

### ***Rear-Facing Child Seat Installation Tips***

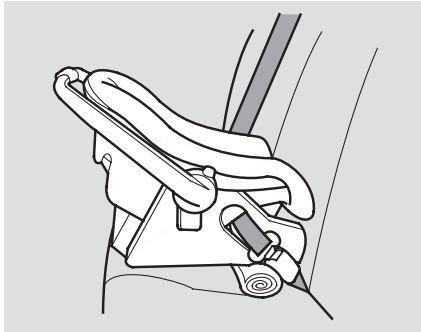

For proper protection, an infant must ride in a reclined, or semi-reclined position. To determine the proper reclining angle, check with the baby's doctor or follow the seat maker's recommendations.

To achieve the desired reclining angle, it may help to put a rolled up towel under the toe of the child seat, as shown.

### **Protecting Small Children**



#### ***Child Seat Type***

A child at least one year old who can sit up without support, and who fits within the child seat maker's weight and height limits, should be restrained in a forward-facing, upright child seat.

Of the different seats available, we recommend those that have a five-point harness system as shown.

We also recommend that a small child stay in the child seat as long as possible, until the child reaches the weight or height limit for the seat.

#### ***Child Seat Placement***

In this car, the best place to install a forward-facing child seat is in one of the seating positions in the back seat.

***Placing a forward-facing child seat in the front seat of a car equipped with a passenger airbag can be hazardous.***

If the vehicle seat is too far forward, or the child's head is thrown forward during a collision, an inflating passenger's airbag can strike the child with enough force to cause very serious or fatal injuries. If a small child must be closely watched, we recommend that another adult sit in the back seat with the child.

*CONTINUED*

## Protecting Children

### **⚠ WARNING**

Improperly placing a forward-facing child seat in the front seat can result in serious injury or death if the front airbags inflate.

If you must place a forward-facing child seat in front, move the vehicle seat as far back as possible and properly restrain the child.

If it is necessary to put a forward-facing child seat in the front, move the vehicle seat as far to the rear as possible, be sure the child seat is firmly secured to the car, and the child is properly strapped in the seat.

### ***Child Seat Installation***

The lap/shoulder belts in the back and front passenger seating positions have a locking mechanism that must be activated to secure a child seat.

The following pages provide instructions on how to secure a forward-facing child seat with this type of seat belt.

If you have a child seat designed to attach to the car's LATCH anchorage system, follow the instructions on page 41 .



1. With the child seat in the desired seating position, route the belt through the child seat according to the seat maker's instructions, then insert the latch plate into the buckle.

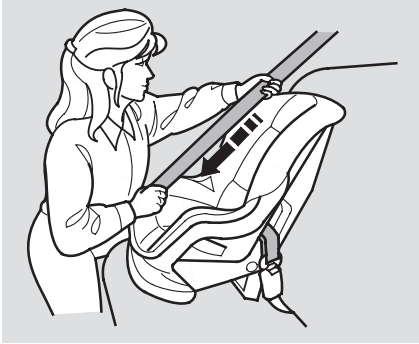

2. To activate the lockable retractor, slowly pull the shoulder part of the belt all the way out until it stops, then let the belt feed back into the retractor.
3. After the belt has retracted, tug on it. If the belt is locked, you will not be able to pull it out. If you can pull the belt out, it is not locked and you will need to repeat these steps.



4. After confirming that the belt is locked, grab the shoulder part of the belt near the buckle and pull up to remove any slack from the lap part of the belt. Remember, if the lap part of the belt is not tight, the child seat will not be secure. It may help to put weight on the child seat, or push on the back of the seat, while pulling up on the belt.

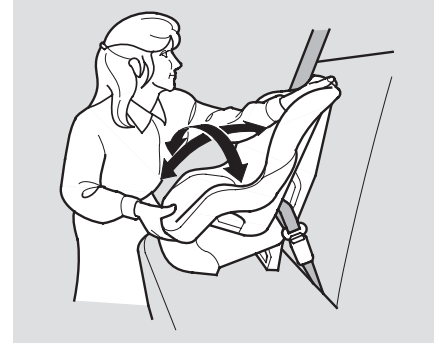

5. Push and pull the child seat forward and from side to side to verify that it is secure enough to stay upright during normal driving maneuvers. If the child seat is not secure, unlatch the belt, allow it to retract fully, then repeat these steps.

To deactivate the locking mechanism and remove a child seat, unlatch the buckle, unrout the seat belt, and let the belt fully retract.

## Protecting Children

### Protecting Larger Children

When a child reaches the recommended weight or height limit for a forward-facing child seat, the child should sit in the back seat on a booster and wear a lap/shoulder belt.

We recommend that the child use a booster seat until the child is tall enough to use the seat belt without a booster.

The following pages give instructions on how to check proper seat belt fit, what kind of booster seat to use if one is needed, and important precautions for a child who must sit in the front seat.

### **⚠ WARNING**

Allowing a larger child to sit improperly in the front seat can result in injury or death if the passenger's front airbag inflates.

If a larger child must sit in front, make sure the child moves the seat as far back as possible, uses a booster seat if needed, and wears the seat belt properly.

### *Checking Seat Belt Fit*



To determine if a lap/shoulder belt properly fits a child, have the child sit in the rear seat, all the way back against the seat, and put on the seat belt. Follow the instructions on page [15](#). Then check how the belt fits.

If the shoulder part of the belt rests over the child's collarbone and against the center of the chest, and the lap belt rests over the child's hipbones and touches the tops of the thighs as shown, the child is probably big enough to wear the seat belt.

However, if the shoulder belt touches or crosses the child's neck, or if the lap belt crosses the child's stomach, the child needs to use a booster seat.

***Do not let a child wear a seat belt across the neck or over the stomach.*** This could result in serious neck and internal injuries during a crash.

***Do not let a child put the shoulder part of a seat belt behind the back or under the arm.*** This could cause very serious injuries during a crash. It also increases the chance that the child will slide under the belt in a crash and be injured.

***Do not put any accessories on a seat belt.*** Devices intended to improve occupant comfort or reposition the shoulder part of a seat belt, severely compromise the protective capability of the seat belt and increase the chance of serious injury in a crash.

***Two children should never use the same seat belt.*** If they do, they could be very seriously injured in a crash.

### *Using a Booster Seat*



If a child needs a booster seat, we recommend choosing a high or low-back style that allows the child to be directly secured with the lap/shoulder belt.

Whichever style you select, follow the booster seat maker's instructions.

*CONTINUED*



## Protecting Children

---

A child should continue using a booster seat until they exceed the booster seat manufacturer's requirements.

Even then, the child may still need to use a booster seat. Note that some states now require children to use boosters until they reach a certain age and/or weight. Be sure to check current laws in the state or states where you intend to drive.

***When Can a Larger Child Sit in Front***  
The National Highway Traffic Safety Administration and Transport Canada recommend that all children ages 12 and under be properly restrained in a back seat.

The back seat is the safest place for a child of any age or size.

In addition, the passenger's front airbag poses serious risks to children. If the seat is too far forward, or the child's head is thrown forward during a collision, or the child is unrestrained or out of position, an inflating front airbag can kill or seriously injure the child.

The side airbag also poses risks. If any part of a larger child's body is in the path of a deploying airbag, the child could receive possibly serious injuries.

Of course, children vary widely. And while age may be one indicator of when a child can safely ride in the front, there are other important factors you should consider.

### ***Physical Size***

Physically, a child must be large enough for the lap/shoulder belt to properly fit over the hips, chest, and shoulder (see pages [15](#) and [36](#)). If the seat belt does not fit properly, the child should not sit in the front.

### ***Maturity***

To safely ride in front, a child must be able to follow the rules, including sitting properly and wearing the seat belt properly throughout a ride.

If you decide that a child can safely ride up front, be sure to:

- Carefully read the owner's manual and make sure you understand all seat belt instructions and all safety information.
- Move the vehicle seat to the rear-most position.
- Have the child sit up straight, back against the seat, and feet on or near the floor.
- Check that the child's seat belt is properly positioned and secured.
- Remind the child not to lean toward the door because of the side airbag.
- Supervise the child. Even mature children sometimes need to be reminded to fasten the seat belts or sit properly.

### Using Child Seats with Tethers

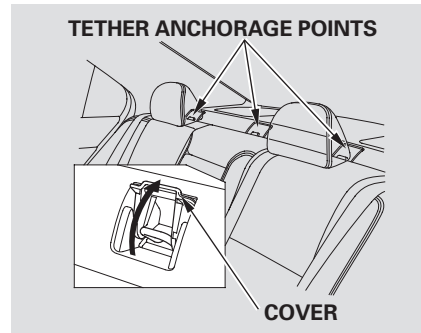

Your car has three tether anchorage points for securing a tether-style child seat to the car. One tether anchorage point for each of the outer rear seat and center rear seat is located under the rear window.

To use the anchorage point, pivot its cover up.

Since a tether can provide additional security, we recommend using a tether whenever one is required or available. (Tethers are required in Canada.)

## Protecting Children

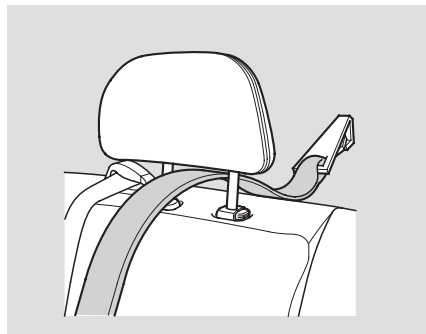

To use either outside anchorage point, lift the rear head restraint, then route the tether strap over the seat-back between the legs of the head restraint.

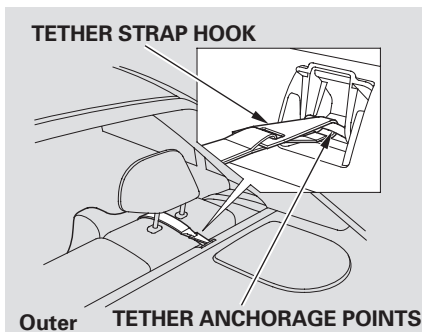

Attach the tether strap hook to the tether anchorage point as shown in the illustration, then tighten the strap according to the child seat maker's instructions. Make sure the strap is not twisted.

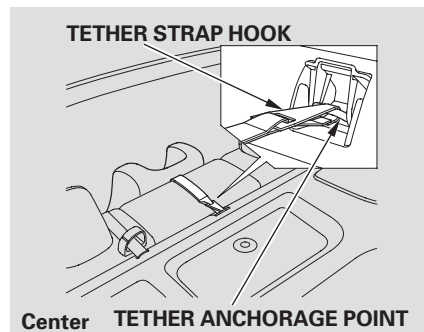

## Protecting Children

---

A child should continue using a booster seat until they exceed the booster seat manufacturer's requirements.

Even then, the child may still need to use a booster seat. Note that some states now require children to use boosters until they reach a certain age and/or weight. Be sure to check current laws in the state or states where you intend to drive.

***When Can a Larger Child Sit in Front***  
The National Highway Traffic Safety Administration and Transport Canada recommend that all children ages 12 and under be properly restrained in a back seat.

The back seat is the safest place for a child of any age or size.

In addition, the passenger's front airbag poses serious risks to children. If the seat is too far forward, or the child's head is thrown forward during a collision, or the child is unrestrained or out of position, an inflating front airbag can kill or seriously injure the child.

The side airbag also poses risks. If any part of a larger child's body is in the path of a deploying airbag, the child could receive possibly serious injuries.

Of course, children vary widely. And while age may be one indicator of when a child can safely ride in the front, there are other important factors you should consider.

### ***Physical Size***

Physically, a child must be large enough for the lap/shoulder belt to properly fit over the hips, chest, and shoulder (see pages 15 and 36 ). If the seat belt does not fit properly, the child should not sit in the front.

### ***Maturity***

To safely ride in front, a child must be able to follow the rules, including sitting properly and wearing the seat belt properly throughout a ride.

## Protecting Children

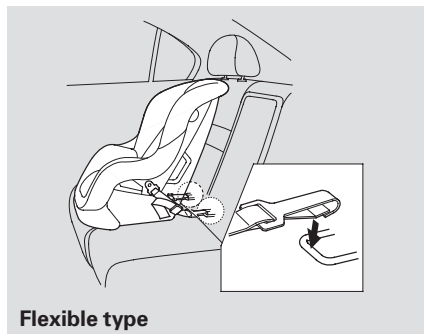

4. Follow the child seat maker's instructions for any additional advice on adjusting or tightening the fit.

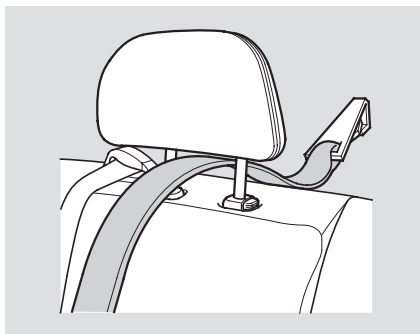

5. Lift the rear head restraint, then route the tether strap over the seat-back between the legs of the head restraint.
6. Attach the tether strap hook to the tether anchorage point, and tighten the strap according to the child seat maker's instructions. Make sure the strap is not twisted. Route it between the legs of the head restraint.

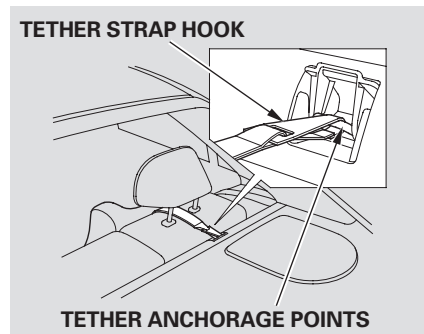

7. Push and pull the child seat forward and from side to side to verify that it is secure enough to stay upright during normal driving maneuvers.

## Additional Information About Your Seat Belts

### Seat Belt System Components

Your seat belt system includes lap/shoulder belts in all five seating positions. The front seat belts are also equipped with automatic seat belt tensioners.



The seat belt system also includes a light on the instrument panel to remind you and your passengers to fasten your belts. If the driver's seat belt is not fastened before the ignition is turned ON (II), the light will come on and a beeper will also sound. The beeper will stop after a few seconds, but the light will stay on until the driver's seat belt is fastened.

### Lap/Shoulder Belt

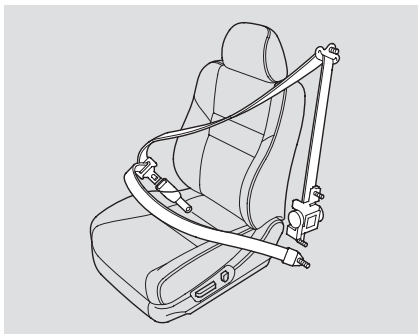

This seat belt has a single belt that goes over your shoulder, across your chest and across your hips.

To fasten the belt, insert the latch plate into the buckle, then tug on the belt to make sure the buckle is latched.

To unlock the belt, push the red PRESS button on the buckle. Guide the belt across your body to the door pillar. After exiting the car, be sure the belt is out of the way and will not get closed in the door.

All seat belts have an emergency locking retractor. In normal driving, the retractor lets you move freely in your seat while it keeps some tension on the belt. During a collision or sudden stop, the retractor automatically locks the belt to help restrain your body.

The seat belts in all seating positions except the driver's have an additional locking mechanism that must be activated to secure a child seat. (See pages 31 and 34 for instructions on how to secure child seats with this type of seat belt.)

*CONTINUED*

## Additional Information About Your Seat Belts

---

If the shoulder part of the belt is pulled all the way out, the locking mechanism will activate. The belt will retract, but it will not allow the passenger to move freely.

To deactivate the locking mechanism, unlatch the buckle and let the seat belt fully retract. To refasten the belt, pull it out only as far as needed.

See page 15 for instructions on how to wear the lap/shoulder belt properly.

### Automatic Seat Belt Tensioners



For added protection, the front seat belts are equipped with automatic seat belt tensioners. When activated, the tensioners immediately tighten the belts to help hold the driver and a front passenger in place.

The tensioners are designed to activate primarily in frontal collisions. The tensioners are independent of the airbag system, so they can be activated during a collision that

might not cause the airbags to deploy. In this case, the airbags would not be needed but the additional seat belt tension can be helpful.

The tensioners will be activated in a collision severe enough to cause the front airbags to inflate.

When the tensioners are activated, the seat belts will remain tight until they are unbuckled in the normal way.



The SRS indicator light will come on if there is a problem with your automatic seat belt tensioners (see page 49).

## Additional Information About Your Seat Belts

### Seat Belt Maintenance

For safety, you should check the condition of your seat belts regularly.

Pull each belt out fully and look for frays, cuts, burns, and wear. Check that the latches work smoothly and that the lap/shoulder belts retract easily. Any belt not in good condition or not working properly will not provide good protection and should be replaced as soon as possible.

### *U.S. Models*

Acura provides a lifetime warranty on seat belts. Acura will repair or replace any seat belt component that fails to function properly during normal use. Please see your *Acura Warranty Information* booklet for details.

### **⚠ WARNING**

Not checking or maintaining seat belts can result in serious injury or death if the seat belts do not work properly when needed.

Check your seat belts regularly and have any problem corrected as soon as possible.

If a seat belt is worn during a crash, it must be replaced by the dealer. A belt that has been worn during a crash may not provide the same level of protection in a subsequent crash. The dealer should also inspect the anchors for damage and replace them if needed.

Automatic seat belt tensioners that deployed during a crash must be replaced.

For information on how to clean your seat belts, see page [299](#).



## Additional Information About Your Airbags

---

### SRS Components

Your Supplemental Restraint System (SRS) includes:

- Two front airbags. The driver's airbag is stored in the center of the steering wheel; the front passenger's airbag is stored in the dashboard. Both are marked "SRS AIRBAG."
- Automatic seat belt tensioners (see page 44).
- Sensors that can detect a moderate to severe frontal collision.

- A sophisticated electronic system that continually monitors and records information about the sensors, the control unit, the airbag activators, and driver and passenger seat belt use when the ignition is ON (II).
- An indicator light on the instrument panel that alerts you to a possible problem with the system (see page 49).
- Emergency backup power in case your car's electrical system is disconnected in a crash.

### How Your Front Airbags Work

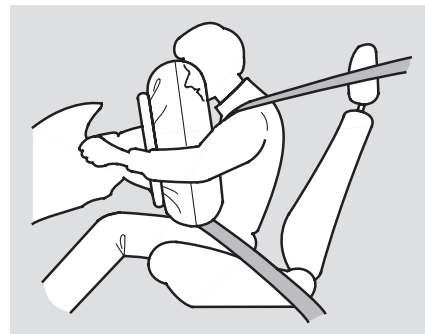

Your car is equipped with dual-stage, dual-threshold airbags to help reduce the chance of airbag-caused injuries.

## Additional Information About Your Airbags

If you ever have a moderate to severe frontal collision, the sensors will detect the car's rapid deceleration. If the rate of deceleration is high enough, the control unit will instantly inflate the front airbags.

During a frontal crash, your seat belts help restrain your lower body and torso. Your airbag provides a cushion to help restrain and protect your head and chest.

Since both airbags use the same sensors, both airbags normally inflate at the same time. However, it is possible for only one airbag to inflate.

This can occur when the severity of a collision is at the margin, or threshold, that determines whether or not the airbags will deploy. In such cases, the seat belt will provide sufficient protection, and the supplemental protection offered by the airbag would be minimal.

After inflating, the front airbags immediately deflate, so they won't interfere with the driver's visibility, or the ability to steer or operate other controls.

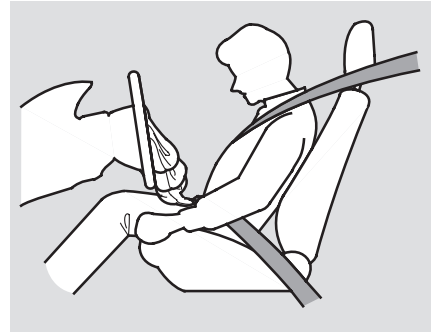

The total time for inflation and deflation is approximately one-tenth of a second, so fast that most occupants are not aware that the airbags deployed until they see them lying in their laps.

*CONTINUED*

## Additional Information About Your Airbags

---

After a crash, you may see what looks like smoke. This is actually powder from the airbag's surface. Although the powder is not harmful, people with respiratory problems may experience some temporary discomfort. If this occurs, get out of the car as soon as it is safe to do so.

### How Your Side Airbags Work

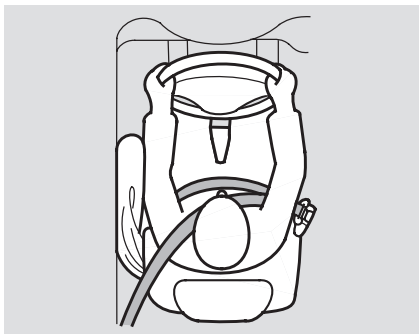

Your car is equipped with side airbags for the driver and a front seat passenger. The airbags are stored in the outer edges of the front seat-backs, and both are marked "SIDE AIRBAG."

In a moderate to severe side impact, the sensors will detect rapid deceleration and signal the control unit to instantly inflate either the driver's or the passenger's side airbag.

Only one airbag will deploy during a side impact. If the impact is on the passenger's side, the passenger's side airbag will deploy even if there is no passenger.

To get the best protection from the side airbags, front seat occupants should wear their seat belts and sit upright and well back in their seats.

## Additional Information About Your Airbags

### How Your Side Curtain Airbags Work

*Standard on U.S. models, Optional on Canadian models*

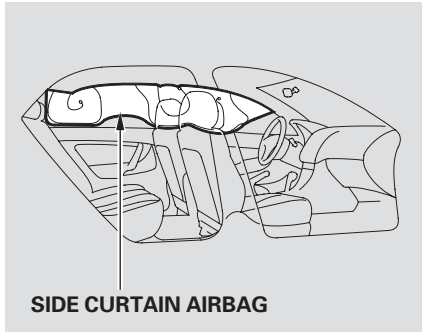

Your car is equipped with side curtain airbags. These airbags are stored in the front, center, and rear pillars on both sides. The front and rear pillars on both sides are marked "SIDE CURTAIN AIRBAG."

In a moderate to severe side impact, sensors will detect rapid deceleration and signal the control unit to instantly inflate the side curtain airbag on the driver's or the passenger's side of the car. If the impact is on the passenger's side, the passenger's side curtain airbag will inflate even if there are no occupants on that side of the car.

To get the best protection from the side curtain airbags, occupants should wear their seat belts and sit upright and well back in their seats.

### How the SRS Indicator Works



The SRS indicator alerts you to a potential problem with the front airbags or seat belt tensioners. If equipped, it also alerts you to a potential problem with the side airbags, the automatic cutoff system for the passenger's side airbag, or the side curtain airbags.

When you turn the ignition switch to ON (II), this indicator will light briefly then go out. This tells you that the system is working properly.

*CONTINUED*

## Additional Information About Your Airbags

---

If the light comes on at any other time, or does not come on at all, you should have the system checked by your dealer. For example:

- If the SRS indicator light does not come on after you turn the ignition switch to ON (II).
- If the light stays on after the engine starts.
- If the light comes on or flashes on and off while you drive.

If you see any of these indications, your airbags may not deploy, your passenger's side airbag automatic cutoff system may not work properly, or your seat belt tensioners may not work when you need them. See your Acura dealer as soon as possible.

### **WARNING**

Ignoring the SRS indicator light can result in serious injury or death if the airbags, cutoff system, or tensioners do not work properly.

Have your car checked by a dealer as soon as possible if the SRS light alerts you to a potential problem.

### **How the Side Airbag Cutoff Indicator Light Works**



This light alerts you that the passenger's side airbag has been automatically shut off.

To reduce the risk of injury from an inflating side airbag, your car has an automatic cutoff system for the passenger's side airbag.

It does not mean there is a problem with your side airbags. It means that the side airbag cutoff system has activated to prevent the side airbag from deploying.

## Additional Information About Your Airbags

---

Although Acura does not encourage children to ride in the front seat, this system is designed to shut off the side airbag if a child leans sideways and the child's head is in the side airbag deployment path.

If a small-statured adult leans sideways, or larger adult slouches and leans sideways into the deployment path of the side airbag, the system may also shut off the side airbag.

If the side airbag cutoff indicator light comes on, you should have the passenger sit upright. Once the passenger is out of the deployment path of the side airbag, the system will turn the airbag back on and the light will go out.

A front seat passenger should not use a cushion or other object as a backrest. It may prevent the cutoff system from working properly.

When you turn the ignition switch to ON (II), the indicator should light briefly and go out (see page 61). If it doesn't light, stays on, or comes on while driving without a passenger in the front seat, have the system checked.

### Airbag Service

Your airbag systems are virtually maintenance-free, and there are no parts you can safely service. However, you must have your car serviced if:

- ***Your airbags ever inflate.*** Any airbag that has deployed must be replaced along with the control unit, automatic seat belt tensioners and other related parts. Do not try to remove or replace any airbag by yourself. This must be done by an Acura dealer or a knowledgeable body shop.
- ***The SRS indicator light alerts you to a problem.*** Take your car to an authorized Acura dealer as soon as possible. If you ignore this indication, the airbags might not inflate when you need them.

## Additional Information About Your Airbags

---

### Additional Safety Precautions

- **Do not attempt to deactivate your airbags.** Together, airbags and seat belts provide the best protection.
- **Do not tamper with airbag components or wiring for any reason.** Tampering could cause the airbags to deploy, possibly causing very serious injury.
- **Do not expose the front seat-backs to water.** If rain or spilled water soaks into a seat-back, it can prevent the side airbag system from working properly.

- **Do not cover or replace front seat-back covers without consulting an Acura dealer.** Improperly replacing or covering front seat-back covers can prevent your side airbags from inflating during a collision.

See page [192](#) for further information and precautions relating to your airbags.

Your car's exhaust contains carbon monoxide gas. You should have no problem with carbon monoxide entering the car in normal driving if you maintain your car properly. Have the exhaust system inspected for leaks whenever:

- The car is raised for an oil change.
- You notice a change in the sound of the exhaust.
- The car was in an accident that may have damaged the underside.

### **WARNING**

Carbon monoxide gas is toxic. Breathing it can cause unconsciousness and even kill you.

Avoid any enclosed areas or activities that expose you to carbon monoxide.

High levels of carbon monoxide can collect rapidly in enclosed areas, such as a garage. Do not run the engine with the garage door closed. Even with the door open, run the engine only long enough to move the car out of the garage.

With the trunk lid open, air flow can pull exhaust gas into your car's interior and create a hazardous condition. If you must drive with the trunk lid open, open all the windows and set the heating and cooling system as shown below.

If you must sit in your parked car, even in an unconfined area, with the engine running, adjust the heating and cooling system as follows:

1. Select the Fresh Air mode.
2. Select the  mode.
3. Turn the fan on high speed.
4. Set the temperature control to a comfortable setting.



# Safety Labels

These labels are in the locations shown. They warn you of potential hazards that could cause serious injury. Read these labels carefully. If a label comes off or becomes hard to read (except for the U.S. dashboard label which is removed by the owner), contact your Acura dealer for a replacement.

## RADIATOR CAP



## DASHBOARD

*U.S. models only*



### HOOD

**▲ WARNING**

Accidental deployment can seriously hurt or kill you.  
Follow Service Manual instructions carefully.

**▲ ATTENTION**

Un déploiement accidentel risque de causer de graves blessures, voire mort.  
Suivre attentivement les Instructions du manuel de réparation.

*On models with side curtain airbags*

*U.S. models*

**▲ WARNING**

Accidental deployment can seriously hurt or kill you.  
Follow Service Manual instructions carefully.

*Canadian models*

**▲ WARNING**

Accidental deployment can seriously hurt or kill you.  
Suivre attentivement les Instructions du manuel de réparation.

**▲ ATTENTION**

Un déploiement accidentel risque de causer de graves blessures, voire mort.  
Suivre attentivement les Instructions du manuel de réparation.

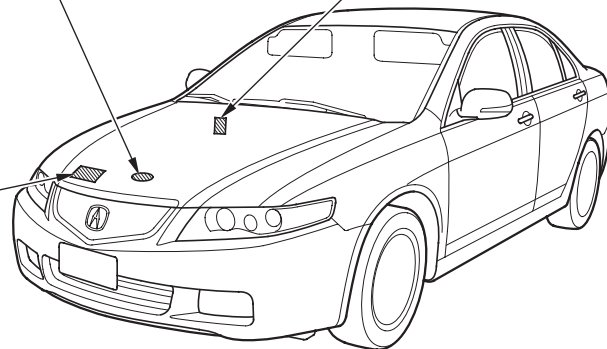

## SUN VISOR

*U.S. models*

**⚠ WARNING**



**DEATH or SERIOUS INJURY can occur**

- Children 12 and under can be killed by the air bag
- The **BACK SEAT** is the **SAFEST** place for children
- NEVER put a rear-facing child seat in the front
- Sit as far back as possible from the air bag
- ALWAYS use SEAT BELTS and CHILD RESTRAINTS

*Canadian models*

<p><b>CAUTION</b> TO AVOID SERIOUS INJURY: • FOR MAXIMUM SAFETY PROTECTION IN ALL TYPES OF CRASHES, YOU MUST ALWAYS WEAR YOUR SAFETY BELT. • DO NOT INSTALL REARWARD-FACING CHILD SEATS IN ANY FRONT PASSENGER SEAT POSITION. • DO NOT SIT OR LEAN UNNECESSARILY CLOSE TO THE AIR BAG. • DO NOT PLACE ANY OBJECTS OVER THE AIR BAG OR BETWEEN THE AIR BAG AND YOURSELF. • SEE THE OWNER'S MANUAL FOR FURTHER INFORMATION AND EXPLANATIONS.</p>	<p><b>PRECAUTION:</b> <b>POUR EVITER DES BLESSURES GRAVES:</b> • POUR PROFITER D'UNE PROTECTION MAXIMALE, LORS D'UNE COLLISION, BOUCLEZ TOUJOURS VOTRE CEINTURE DE SECURITE. • N'INSTALLEZ JAMAIS UN SIEGE POUR ENFANTS FAISANT FACE A L'ARRIERE SUR LE SIEGE DU PASSAGER AVANT. • NE VOUS APPUYEZ PAS ET NE VOUS ASSEYEZ PAS PRES DU COUSSIN GONFLABLE. • NE DEPOSEZ AUCUN OBJET SUR LE COUSSIN GONFLABLE QU'ENTRE LE COUSSIN GONFLABLE ET VOUS. • LISEZ LE GUIDE UTILISATEUR POUR DE PLUS AMPLES RENSEIGNEMENTS.</p>
--	--

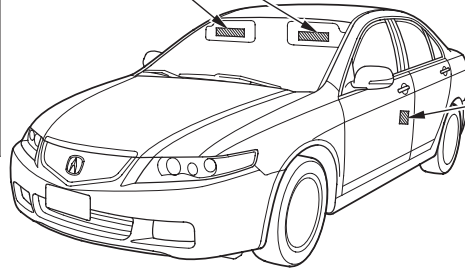

## DOORJAMBS

*U.S. models*

**SIDE AIRBAG**

- This car is equipped with side airbags in the driver's and passenger's seat.
- Do not lean against the door.
- See owner's manual for more information.

*Canadian models*

**SIDE AIRBAG**

- This car is equipped with side airbags in the driver's and passenger's seat.
- Do not lean against the door.
- See owner's manual for more information.

**COUSSIN GONFLABLE LATERAL**

- Cette voiture est équipée de coussins gonflables latéraux dans les sièges du conducteur et du passager.
- Ne vous appuyez pas sur la porte.
- Consultez le Manuel du propriétaire pour en savoir plus.

*On cars with side curtain airbags*

*U.S. models*

**SIDE AIRBAG**

- This car is equipped with side airbags in the front seats and side curtain airbags.
- Do not lean against the door.
- See owner's manual for more information.

*Canadian models*

**SIDE AIRBAG**

- This car is equipped with side airbags in the front seats and side curtain airbags.
- Do not lean against the door.
- See owner's manual for more information.

**COUSSIN GONFLABLE LATERAL**

- Cette automobile est équipée de coussins gonflables latéraux dans les sièges avant ainsi que de coussins gonflables latéraux de type rideau.
- Ne vous appuyez pas sur la porte.
- Consultez le Manuel du propriétaire pour en savoir plus.



This section gives information about the controls and displays that contribute to the daily operation of your Acura. All the essential controls are within easy reach.

Control Locations .....	58	Temperature Gauge .....	66	Glove Box .....	89
Indicator Lights.....	59	Fuel Gauge .....	67	Seat Adjustments.....	90
Gauges .....	65	Maintenance Required Indicator.....	67	Driver's Seat Full Power Adjustments .....	90
Speedometer .....	65	Controls Near the Steering Wheel .....	69	Driver's Lumbar Support.....	91
Tachometer .....	65	Headlights .....	70	Front Passenger's Seat Adjustments .....	92
Odometer.....	65	Automatic Lighting Off Feature.....	71	Head Restraints .....	93
Outside Temperature Indicator.....	66	Daytime Running Lights.....	72	Folding Rear Seat .....	94
Trip Meter .....	66	Instrument Panel Brightness.....	72	Rear Seat Armrest.....	95
		Turn Signals .....	73	Seat Heaters .....	96
		Windshield Wipers .....	73	Power Windows .....	97
		Windshield Washers .....	75	Moonroof .....	101
		Hazard Warning.....	75	Mirrors.....	102
		Rear Window Defogger .....	75	Adjusting the Power Mirrors ..	102
		Steering Wheel Adjustment .....	76	Parking Brake .....	104
		Keys and Locks.....	77	Console Compartment .....	105
		Keys.....	77	Armrest.....	105
		Immobilizer System.....	79	Beverage Holders.....	106
		Ignition Switch .....	80	Center CD Pocket.....	107
		Power Door Locks.....	81	Utility Pocket.....	107
		Remote Transmitter.....	83	Sun Visor.....	108
		Childproof Door Locks .....	87	Vanity Mirror .....	108
		Trunk .....	87	Sunglasses Holder .....	109
		Emergency Trunk Opener .....	88	Accessory Power Sockets.....	109
				Interior Lights .....	110

## Control Locations

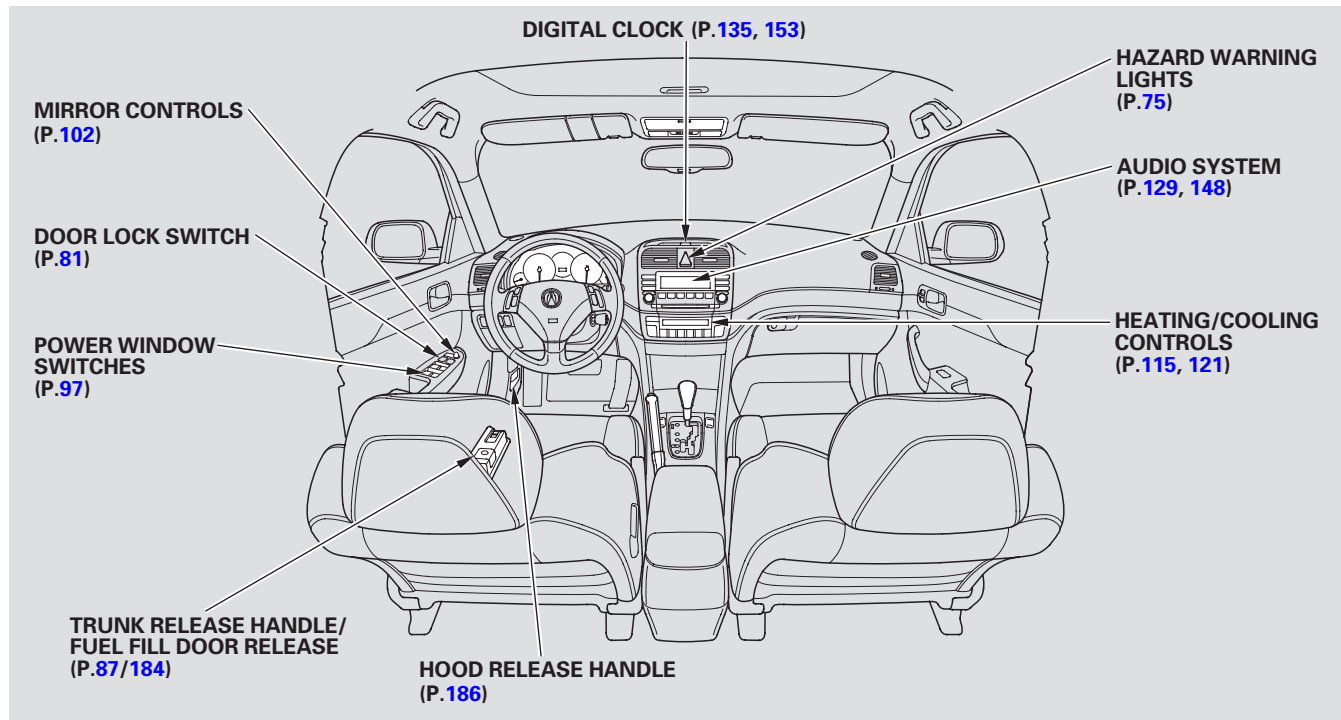

# Indicator Lights

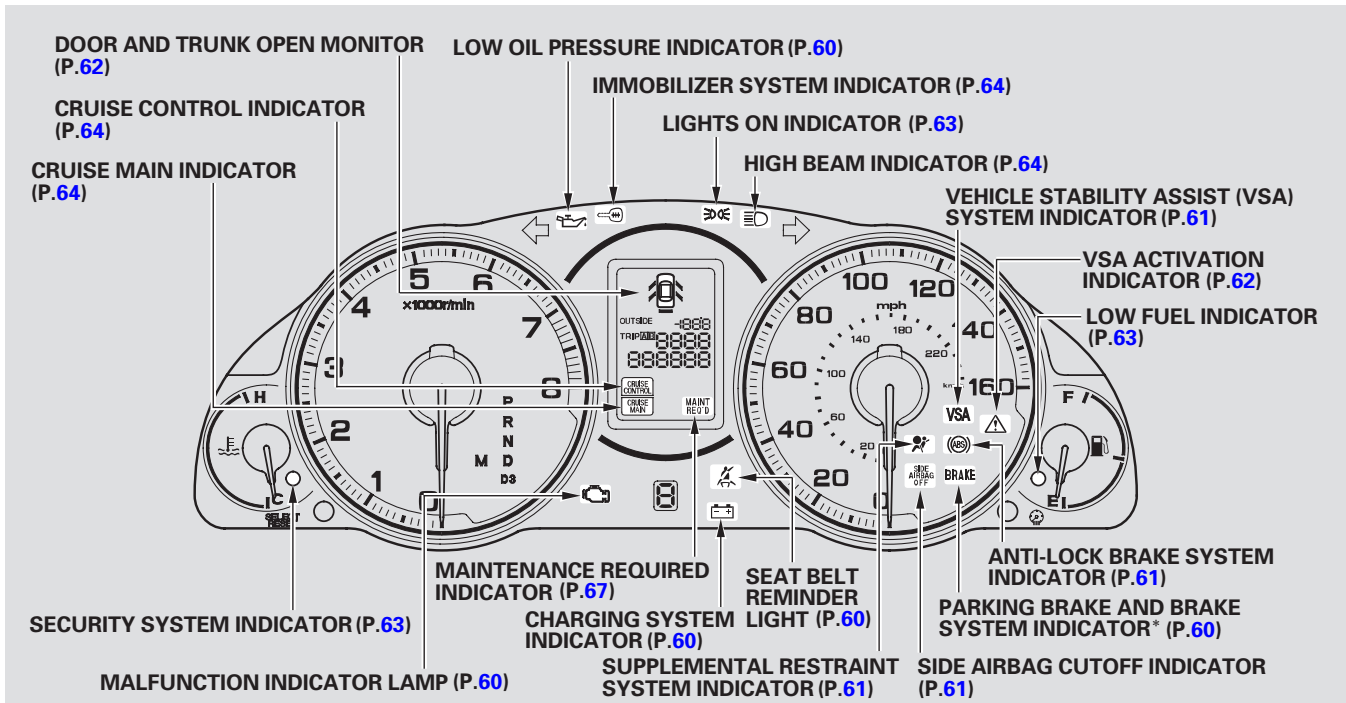

The U.S. instrument panel is shown. Differences for the Canadian models are noted in the text.

## Indicator Lights

---

The instrument panel has many indicators to give you important information about your car.



### Seat Belt Reminder Light

This indicator lights when you turn the ignition switch ON (II). It is a reminder to you and your passengers to protect yourselves by fastening the seat belts. A beeper also sounds if you have not fastened your seat belt.

If you do not fasten your seat belt, the beeper will stop after a few seconds but the light stays on until you do. Both the light and the beeper stay off if you fasten your seat belt before turning on the ignition.



### Low Oil Pressure Indicator

The engine can be severely damaged if this light flashes or stays on when the engine is running. For complete information, see page [317](#).



### Charging System Indicator

If this light comes on when the engine is running, the battery is not being charged. For complete information, see page [318](#).



### Malfunction Indicator Lamp

See page [319](#).

U.S.

BRAKE

Canada



### Parking Brake and Brake System Indicator

This light has two functions:

1. This indicator comes on when you turn the ignition switch ON (II). It is a reminder to check the parking brake. A beeper sounds if you try to drive with the parking brake not fully released. Driving with the parking brake not fully released can damage the brakes and tires.
2. If the indicator remains lit after you have fully released the parking brake while the engine is running, or if it comes on while driving, it can indicate a problem in the brake system. For complete information, see page [321](#).



### Supplemental Restraint System Indicator

This indicator lights briefly when you turn the ignition switch to ON (II). If it comes on at any other time, it indicates a potential problem with your front airbags. This light will also alert you to a potential problem with your side airbags, passenger's side airbag automatic cutoff system, automatic seat belt tensioners, or side curtain airbags. For complete information, see page [49](#).



### Side Airbag Cutoff Indicator

This indicator lights briefly when you turn the ignition switch ON (II). If it comes on at any other time, it indicates that the passenger's side airbag has automatically shut off. For complete information, see page [50](#).



### Anti-lock Brake System (ABS) Indicator

This light normally comes on for a few seconds when you turn the ignition switch ON (II). If this light comes on at any other time, there is a problem in the ABS. If this happens, take the car to your dealer to have it checked. With the light on, your car still has normal braking ability but no anti-lock. For complete information, see page [213](#).



### Vehicle Stability Assist (VSA) System Indicator

This indicator normally comes on for a few seconds when you turn the ignition switch to ON (II).

If this light comes on and stays on at any other time, or it does not come on when you turn the ignition switch ON (II), there is a problem with the VSA system. Take the car to your dealer to have it checked. Without VSA, your car still has normal driving ability, but will not have VSA traction and stability enhancement. See page [216](#) for more information on the VSA system.



## Indicator Lights

---



### VSA Activation Indicator

This indicator has three functions:

1. It comes on as a reminder that you have turned off the Vehicle Stability Assist (VSA) system.
2. It flashes when VSA is active (see page [216](#)).
3. It comes on along with the VSA system indicator if there is a problem with the VSA system.

This indicator normally comes on for a few seconds when you turn the ignition switch to ON (II). See page [216](#) for more information on the VSA system.

### Door and Trunk Open Monitor

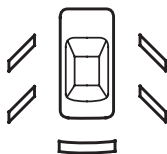

The appropriate light comes on in this display if the trunk or any door is not closed tightly.

All the lights in the monitor display come on for a few seconds when you turn the ignition switch to ON (II).





### Turn Signal and Hazard Warning Indicators

The left or right turn signal light blinks when you signal a lane change or turn. If the light does not blink or blinks rapidly, it usually means one of the turn signal bulbs is burned out (see page [284](#)). Replace the bulb as soon as possible, since other drivers cannot see that you are signaling.

When you turn on the hazard warning switch, both turn signal lights blink, and all turn signals on the outside of the car should flash.



### Lights On Indicator

This indicator reminds you that the exterior lights are on. It comes on when the light switch is in either the  or  position. If you turn the ignition switch to ACCESSORY (I) or LOCK (0) without turning off the light switch, this indicator will remain on. A reminder chime will also sound when you open the driver's door.

### Low Fuel Indicator

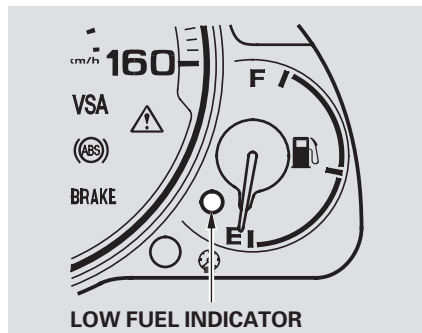

This indicator is located in the fuel gauge. It comes on as a reminder that you must refuel soon.

### Security System Indicator

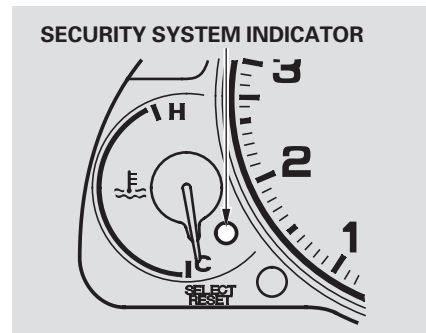

This indicator lights when the security system is set. See page [173](#) for complete information on the security system.

## Indicator Lights

---

**DRL**

### “Daytime Running Lights” Indicator

*Canadian models only*

This indicator lights when you turn the ignition switch to ON (II) with the headlight switch off and the parking brake set. It should go off if you turn on the headlights or release the parking brake. If it comes on at any other time, it means there is a problem with the DRL. There may also be a problem with the high beam headlights.



### High Beam Indicator

This light comes on with the high beam headlights. See page 70 for information on the headlight controls.

On Canadian models, this indicator comes on with reduced brightness when the Daytime Running Lights (DRL) are on (see page 72).

**CRUISE  
MAIN**

### Cruise Main Indicator

This indicator comes on when you turn on the Cruise Control System by pressing the Master Button. (see page 174.)

**CRUISE  
CONTROL**

### Cruise Control Indicator

This lights when you set the cruise control. See page 174 for information on operating the cruise control.



### Immobilizer System Indicator

This indicator comes on for a few seconds when you turn the ignition switch ON (II). It will then go off if you have inserted a properly-coded ignition key. If it is not a properly-coded key, the indicator will blink and the engine will not start (see page 79).

This indicator also blinks several times when you turn the ignition switch from ON (II) to ACCESSORY (I) or LOCK (0).



### Washer Level Indicator

*Canadian models only*

This light comes on when the washer fluid level is low. Add washer fluid when you see this light come on (see page 255).

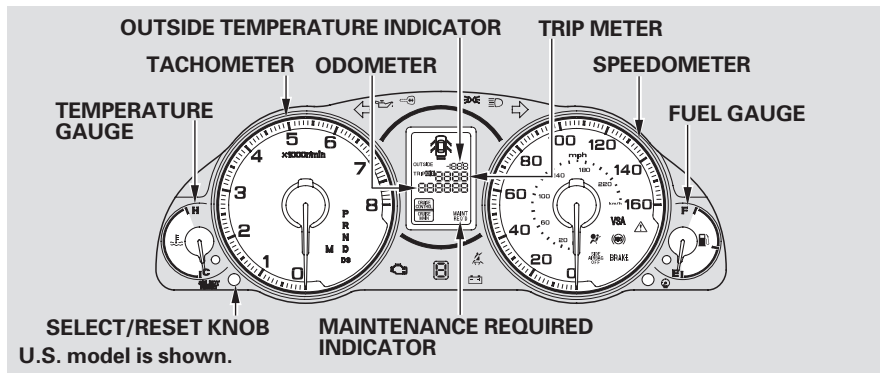

The gauges illuminate when you turn the ignition switch to ON (II).

## Speedometer

### *U.S. Models*

This shows your speed in miles per hour (mph). The smaller inner numbers are the speed in kilometers per hour (km/h).

### *Canadian Models*

This shows your speed in kilometers per hour (km/h). The smaller inner numbers are the speed in miles per hour (mph).

## Tachometer

The tachometer shows the engine speed in revolutions per minute (rpm). To protect the engine from damage, never drive with the tachometer needle in the red zone.

## Odometer

The odometer shows the total distance your car has been driven. It measures miles in U.S. models and kilometers in Canadian models. It is illegal under U.S. federal law and Canadian provincial regulations to disconnect, reset, or alter the odometer with the intent to change the number of miles or kilometers indicated.

## Gauges

---

### Outside Temperature Indicator

This indicator displays the outside Fahrenheit temperature in U.S. models, and Centigrade temperature in Canadian models.

The temperature sensor is located in the front bumper. Therefore, the temperature reading can be affected by heat reflection from the road surface, engine heat, and the exhaust from surrounding traffic. This can cause an incorrect temperature reading when your speed is under 19 mph (30 km/h).

In certain weather conditions, temperature readings near freezing (32°F, 0°C) could mean that ice is forming on the road surface.

### Trip Meter

This meter shows the number of miles (U.S.) or kilometers (Canada) driven since you last reset it.

There are two trip meters: Trip A and Trip B. Switch between these displays by pressing the Select/Reset knob repeatedly. Each trip meter works independently, so you can keep track of two different distances.

When you turn the ignition switch to ON (II), what you last selected is displayed.

To reset a trip meter, display it and then press and hold the Select/Reset knob until the number resets to “0.0”. Both trip meters will reset if the car’s battery goes dead or is disconnected.

### Temperature Gauge

This shows the temperature of the engine’s coolant. During normal operation, the pointer should rise from the bottom white mark to about the middle of the gauge. In severe driving conditions, such as very hot weather or a long period of uphill driving, the pointer may rise into the upper half of the gauge. If it reaches the red (Hot) mark, pull safely to the side of the road. Turn to page [315](#) for instructions and precautions on checking the engine’s cooling system.

### Fuel Gauge

This shows how much fuel you have. It is most accurate when the car is on level ground. It may show slightly more or less than the actual amount when you are driving on curvy or hilly roads.

The needle returns to the bottom after you turn off the ignition. The gauge shows the fuel level reading immediately after you turn the ignition switch to ON (II).

#### NOTICE

*Avoid driving with an extremely low fuel level. Running out of fuel could cause the engine to misfire, damaging the catalytic converter.*

### Maintenance Required Indicator

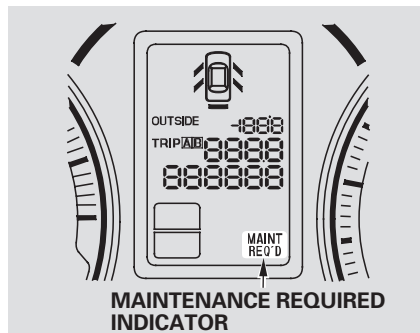

This indicator reminds you that it is time to take your car in for scheduled maintenance per the Normal Conditions maintenance schedule. The indicator light does not reflect severe maintenance intervals.

Refer to the Maintenance Schedules for Normal and Severe Driving Conditions on pages [234](#) – [238](#).

For the first 8,000 miles (12,800 km) after the Maintenance Required Indicator is reset, it will come on for two seconds when you turn the ignition switch to ON (II).

CONTINUED

## Gauges

---

Between 8,000 miles (12,800 km) and 10,000 miles (16,000 km), this indicator will light for two seconds when you first turn the ignition switch to ON (II), and then flash for ten seconds.

If you exceed 10,000 miles (16,000 km) without having the scheduled maintenance performed, this indicator will remain on as a constant reminder.

Your dealer will reset this indicator after completing the scheduled maintenance. If this maintenance is done by someone other than your Acura dealer, reset the indicator as follows.

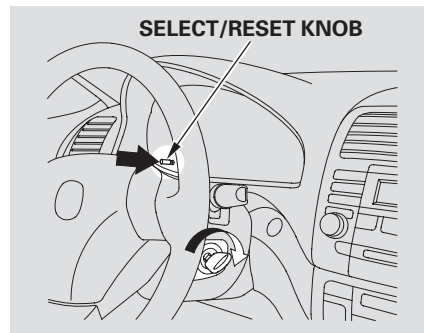

1. Turn off the engine.
2. Press and hold the Select/Reset knob in the instrument panel, then turn the ignition switch to ON (II).
3. Hold the knob for about ten seconds until the indicator resets.

## Controls Near the Steering Wheel

The two levers on the steering column contain controls for the driving features you use most often. The left lever controls the turn signals, headlights, and high beams. The right lever controls the windshield washers and wipers.

The controls under the left air vent are for the moonroof and the VSA System.

The steering wheel adjustment lever on the underside of the steering column allows you to tilt and telescope the steering wheel.

\* To use the horn, press the pad around the “A” logo.

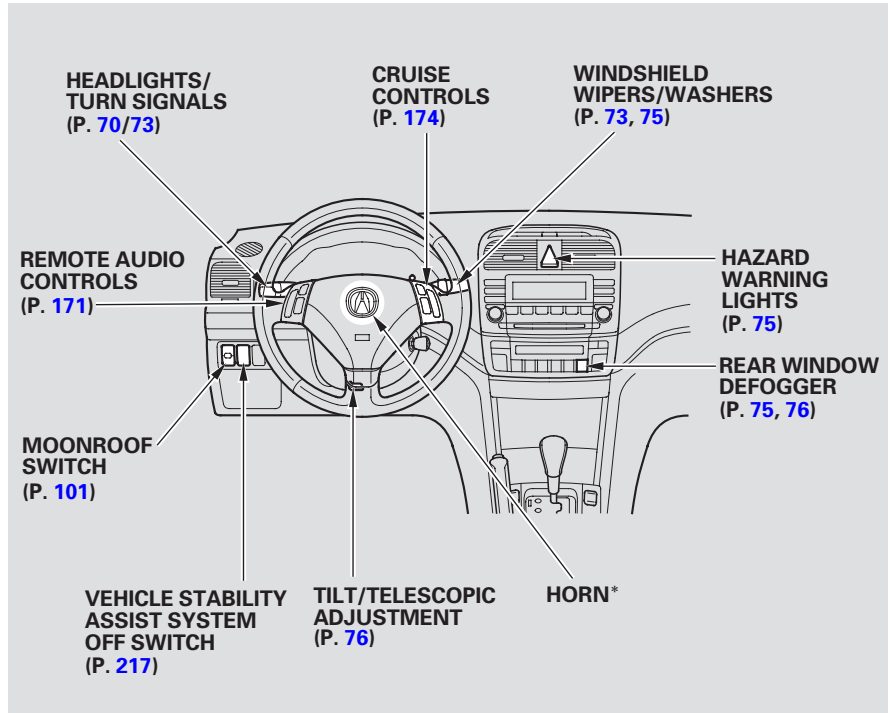



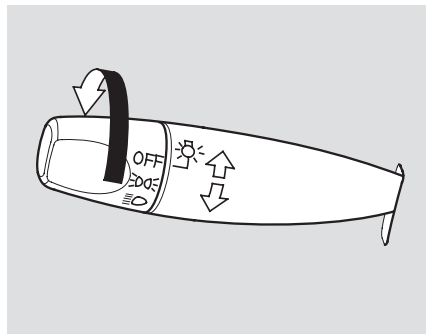

## Controls Near the Steering Wheel

### Headlights



The rotating switch on the left lever controls the lights. Turning this switch to the “ ” position turns on the parking lights, taillights, and rear license plate light. Turning the switch to the “ ” position turns on the headlights.

When the light switch is in either of these positions, the Lights On indicator comes on as a reminder.

If you leave the lights on with the key removed from the ignition switch, you will hear a reminder chime when you open the driver’s door.

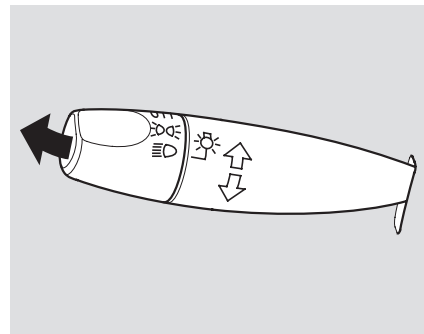

To change from low beams to high beams, push the turn signal lever forward until you hear a click. The blue high beam indicator will light (see page 64 ). To return to low beams, pull the turn signal lever back.

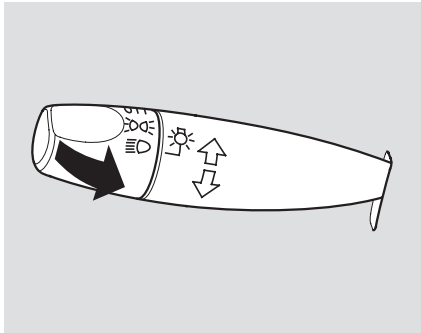



To flash the high beams, pull the turn signal lever back lightly, then release it. The high beams will come on and go off.

The high beams will stay on for as long as you hold the lever back, no matter what position the headlight switch is in.

### Automatic Lighting Off Feature

The Automatic Lighting Off feature turns off the headlights, parking lights, taillights, and license plate light within 15 seconds of removing the key from the ignition switch and closing the driver's door.

This feature activates if you leave the headlight switch in the “ ” or “ ” position, remove the key, then open and close the driver's door.

If you remove the key from the ignition switch with the headlight switch on, but do not open the door and get out, the lights will turn off after ten minutes.

The lights will turn on again when you unlock or open the driver's door. If you unlock the door, but do not open it within 15 seconds, the lights will go off. With the driver's door open, you will hear a lights-on reminder chime.

## Controls Near the Steering Wheel

---

### Daytime Running Lights (Canadian Models)

With the headlight switch off, the high beam headlights and the high beam indicator come on with reduced brightness when you turn the ignition switch to ON (II) and release the parking brake. They remain on until you turn the ignition off, even if you set the parking brake.

The headlights revert to normal operation when you turn them on with the switch.

### Instrument Panel Brightness

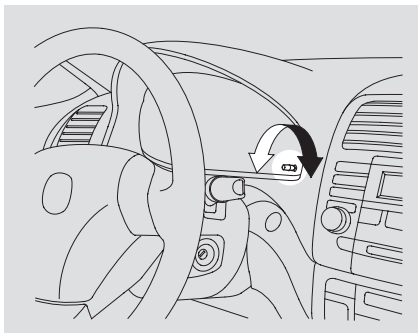

Turn the knob on the right side of the instrument panel to adjust the instrument panel brightness. There are six brightness levels. When you turn the knob, the odometer display changes to circles that show you the current level. The display returns to the odometer values five seconds after you stop adjusting the knob.

The instrument panel will illuminate with reduced brightness when you unlock and open the driver's door. The brightness will increase slightly when you insert the key in the ignition switch, then go to normal brightness when you turn the ignition switch to ON (II).

If you do not insert the key in the ignition switch after opening and closing the driver's door, the illumination turns off in about 30 seconds.

If you insert the key but do not turn the ignition switch to ON (II), the illumination turns off in about 10 seconds.

### Turn Signals

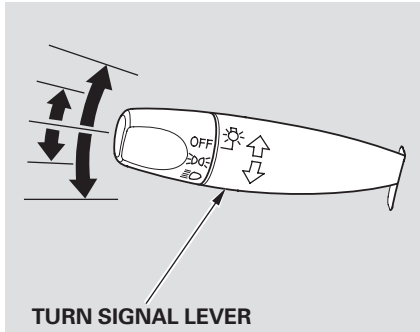

Signal a turn or lane change with this lever. Push down on the lever to signal a left turn, and up to signal a right turn. If you push it up or down all the way, the turn signal continues to blink even when you release the lever. It shuts off automatically as you complete the turn.

To signal a lane change, push lightly on the turn signal lever in the proper direction and hold it. The lever will return to the center position as soon as you release it.

### Windshield Wipers

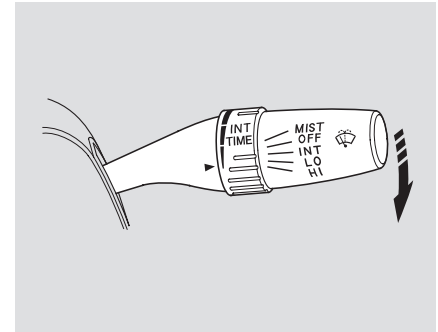

This lever controls the windshield wipers and washers. It has five positions:

- MIST: mist
- OFF: off
- INT: intermittent
- LO: low speed
- HI: high speed

To select a position, push the lever up or down.

*CONTINUED*

## Controls Near the Steering Wheel

In intermittent, the wipers operate every few seconds. The sweep interval will change slightly with speed; getting shorter as you drive faster. While the car is stopped and in gear, the wipers sweep the windshield whenever you remove your foot from the brake pedal. In low speed and high speed, the wipers run continuously.

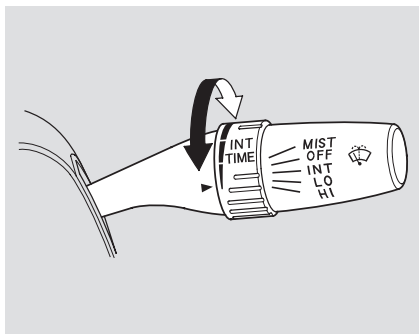

You can vary how often the wipers sweep the windshield by turning the INT TIME ring on the lever.

If you turn the INT TIME ring to the shortest delay, the wipers will change from intermittent to low speed operation when car speed exceeds 12 mph (20 km/h).

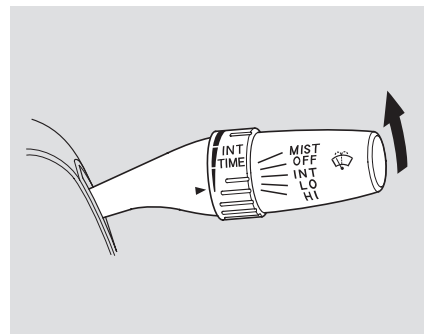

To operate the wipers in mist mode, push the control lever up from the OFF position. The wipers run at high speed until you release the lever. This gives you a quick way to clear the windshield.

### Windshield Washers

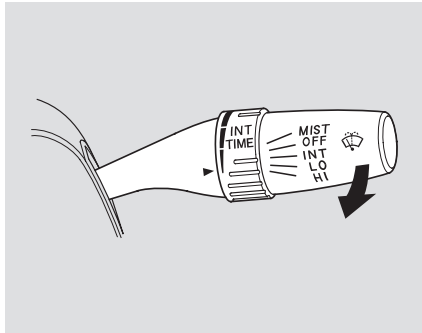

To clean the windshield, pull back on the wiper control lever. The washers spray until you release the lever. The wipers run at low speed while you're pulling the lever, then complete one more sweep of the windshield after you release it.

### Hazard Warning

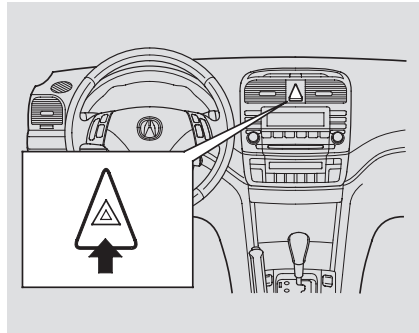

Push the button between the center vents to turn on the hazard warning lights (four-way flashers). This causes all four outside turn signals and both turn indicators in the instrument panel to flash. Use the hazard warning lights if you need to park in a dangerous area near heavy traffic, or if your car is disabled.

### Rear Window Defogger

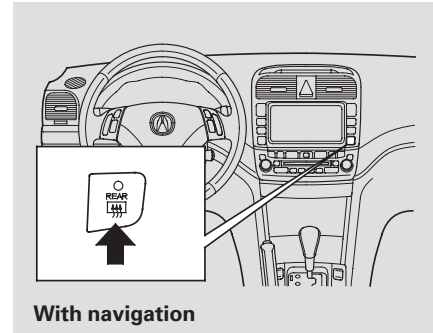

**With navigation**

The rear window defogger will clear fog, frost, and thin ice from the window. Push the defogger button to turn it on and off. The light above the button lights to show the defogger is on. It also shuts off when you turn off the ignition. You have to turn it on again when you restart the car.

*CONTINUED*

## Controls Near the Steering Wheel

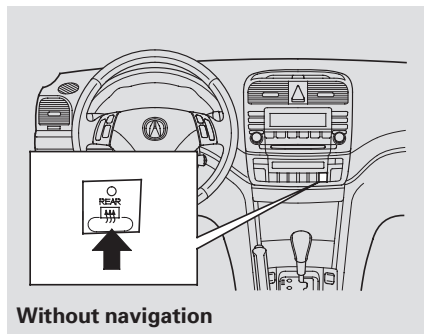

Without navigation

Make sure the rear window is clear and you have good visibility before starting to drive.

The defogger and antenna wires on the inside of the rear window can be accidentally damaged. When cleaning the glass, always wipe side to side.

### Steering Wheel Adjustment

See page 18 for important safety information about how to properly position the steering wheel.

Make any steering wheel adjustment before you start driving.

### **⚠ WARNING**

Adjusting the steering wheel position while driving may cause you to lose control of the car and be seriously injured in a crash.

Adjust the steering wheel only when the car is stopped.

To adjust the steering wheel:

1. Insert the key in the ignition switch, and unlock the steering column.
2. Push the lever under the steering column all the way down.

## Controls Near the Steering Wheel, Keys and Locks

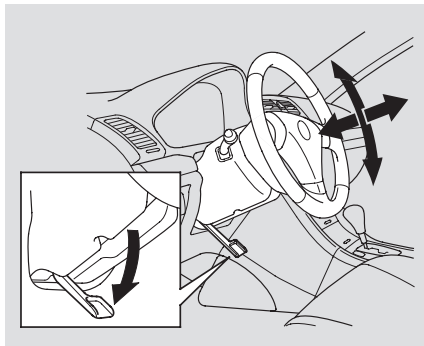

3. Move the steering wheel up or down, and in or out to the desired position, making sure the wheel points toward your chest, not toward your face. Make sure you can see the instrument panel gauges and the indicator lights.

4. Push the lever up to lock the steering wheel in that position.
5. Make sure you have securely locked the steering wheel in place by trying to move it up, down, in, and out.

### Keys

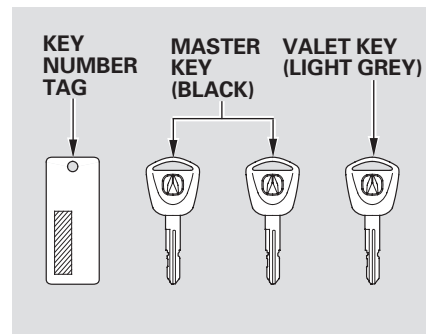

Your car comes with two master keys and a valet key. The master key fits all the locks on your car:

- Ignition
- Driver's door
- Glove box
- Trunk release handle
- Rear seat trunk access

*CONTINUED*



## Keys and Locks

---

The valet key works only in the ignition and the driver's door lock. You can keep the trunk release handle, rear seat trunk access, and glove box locked when you leave your car and the valet key at a parking facility.

You should have received a key number tag with your keys. You will need this key number if you ever have to get a lost key replaced. Keep the tag stored in a safe place. If you need to replace a key, use only an Acura-approved key blank.

These keys contain electronic circuits that are activated by the Immobilizer System. They will not work to start the engine if the circuits are damaged.

- Protect the keys from direct sunlight, high temperature, and high humidity.
- Do not drop the keys or set heavy objects on them.
- Keep the keys away from liquids. If they get wet, dry them immediately with a soft cloth.

The keys do not contain batteries. Do not try to take them apart.

### ***Remote Transmitter***

Your car also comes with two remote transmitters; see page 80 for an explanation of the operation.

### Immobilizer System

The Immobilizer System protects your car from theft. A properly-coded master or valet key must be used in the ignition switch for the engine to start. If an improperly-coded key (or other device) is used, the engine's fuel system is disabled.

When you turn the ignition switch to ON (II), the Immobilizer System indicator should come on for a few seconds, then go out. If the indicator starts to blink, it means the system does not recognize the coding of the key. Turn the ignition switch to LOCK (0), remove the key, reinsert it, and turn the switch to ON (II) again.

The system may not recognize your key's coding if another immobilizer key or other metal object is near the ignition switch when you insert the key. To make sure the system recognizes the key code:

- Do not keep other immobilizer keys on the same key ring.
- Use a plastic or leather key fob, not metal.
- Keep other keys away from your car's key and the ignition switch while trying to start the engine.

If the system repeatedly does not recognize the coding of your key, contact your Acura dealer.

The Immobilizer System indicator will also blink several times when you turn the ignition switch from ON (II) to ACCESSORY (I) or LOCK (0).

Do not attempt to alter this system or add other devices to it. Electrical problems could result that may make your car undriveable.

If you have lost your key and you cannot start the engine, contact your Acura dealer.

*As required by the FCC:*

*This device complies with Part 15 of the FCC rules. Operation is subject to the following two conditions: (1) This device may not cause harmful interference, and (2) this device must accept any interference received, including interference that may cause undesired operation.*

*Changes or modifications not expressly approved by the party responsible for compliance could void the user's authority to operate the equipment.*

*This device complies with Industry Canada Standard RSS-210. Operation is subject to the following two conditions: (1) this device may not cause interference, and (2) this device must accept any interference that may cause undesired operation of the device.*

## Keys and Locks

### Ignition Switch

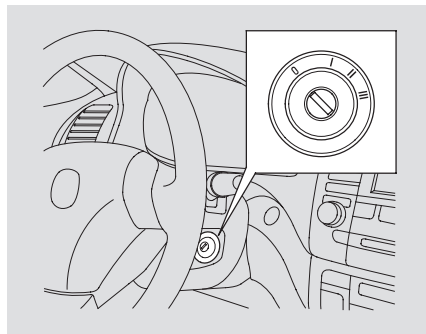

The ignition switch is on the right side of the steering column. It has four positions:

- LOCK (0)
- ACCESSORY (I)
- ON (II)
- START (III)

**LOCK (0)** – You can insert or remove the key only in this position. To switch from ACCESSORY to LOCK, you must push the key in slightly as you turn it. If your car has an automatic transmission, the shift lever must also be in Park. The anti-theft lock will lock the steering column when you remove the key.

If the front wheels are turned, the anti-theft lock may sometimes make it difficult to turn the key from LOCK to ACCESSORY. Firmly turn the steering wheel to the left or to the right as you turn the key.

### **⚠ WARNING**

Removing the key from the ignition switch while driving locks the steering. This can cause you to lose control.

Remove the key from the ignition switch only when parked.

**ACCESSORY (I)** – In this position, you can operate the audio system and the accessory power socket.

**ON (II)** – This is the normal key position when driving. All features and accessories on the car are usable. Several of the lights on the instrument panel come on as a test when you turn the ignition switch from ACCESSORY to ON.

**START (III)** – Use this position only to start the engine. The switch returns to ON (II) when you let go of the key.

The engine will not start if the Immobilizer System does not recognize the key's coding (see page 79 ).

You will hear a reminder beeper if you leave the key in the ignition switch in the LOCK (0) or ACCESSORY (I) position and open the driver's door. Remove the key to turn off the beeper.

### Power Door Locks

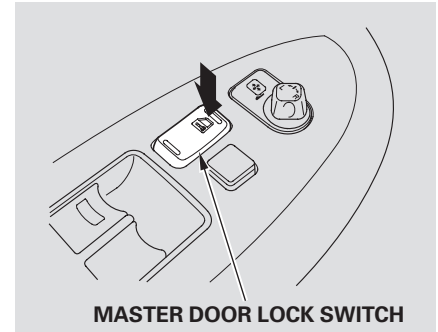

Each front door has a master door lock switch. Either switch locks and unlocks all doors and the trunk. On the driver's door, push the top of the master door lock switch to lock all doors and the trunk, and push the bottom to unlock them.

*CONTINUED*

## Keys and Locks

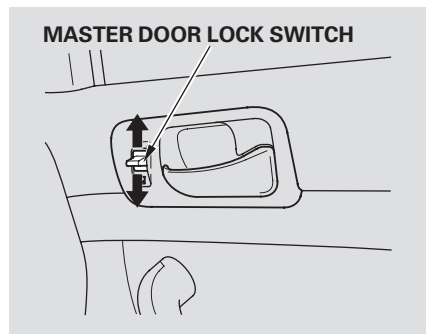

On the front passenger's door, push the master door lock switch down to lock the doors and the trunk, and up to unlock them.

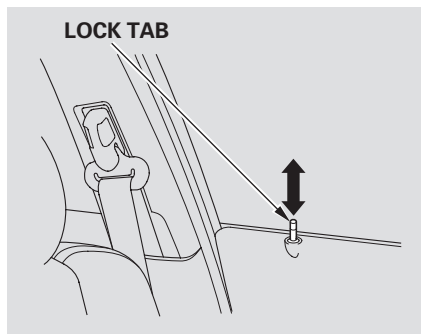

Each door has a lock tab at the top of the door. When you push down the lock tab on the driver's door, all doors and the trunk lock. Pulling up the lock tab on the driver's door unlocks only that door. The lock tab on the passenger's door only locks and unlocks that door.

To lock any passenger's door when getting out of the car, push the lock tab down and close the door. To lock the driver's door, remove the key from the ignition switch, push the lock tab down or push the top of the master switch, then close the door.

All doors and the trunk can be locked from the outside by using the key in the driver's door. To unlock just the driver's door, turn the key and release it. If you turn the key again, all doors and the trunk will unlock.

You can open or close the windows by using the key in the driver's door (see page [100](#)).

### ***Lockout Prevention***

If you forget and leave the key in the ignition switch, Lockout Prevention will not allow you to lock the driver's door. With the driver's door open and the key in the ignition, both master door lock switches are disabled. However, if the driver's door is not open, the master door lock switches are not disabled. If you try to lock an open driver's door by pushing in the lock tab, the tabs on all doors pop out. Pushing in the lock tab on a passenger's door only locks that door.

### **Remote Transmitter**

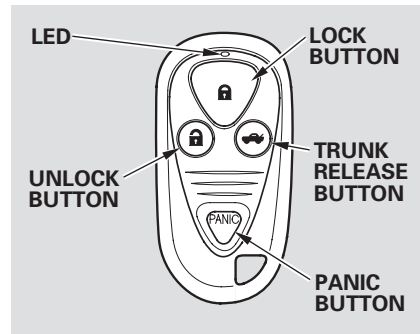

You can lock and unlock your car with the remote transmitter. When you push the LOCK button, all doors and the trunk lock. The parking lights, side marker lights, taillights, and instrument panel lights flash once.

When you push the LOCK button a second time within 5 seconds after locking the doors, you will hear a beep to verify that the doors are locked and the security system has set.

When you push the UNLOCK button once, only the driver's door unlocks. The remaining doors and the trunk unlock when you push the button a second time. The parking lights, side marker lights, taillights, and instrument panel lights flash twice each time you push the button.

You can open and close all power windows from outside the car with the key. With the remote transmitter, you can open the windows. Refer to Power Windows on page [100](#).

*CONTINUED*

## Keys and Locks

---

The ceiling light (if the ceiling light switch is in the center position) and the spotlights (if the switch is in the Door position) will come on when you press the UNLOCK button. If you do not open any door, the lights stay on for about 30 seconds, then fade out. If you relock the doors with the remote transmitter before 30 seconds have elapsed, the lights will go off immediately.

You cannot lock the doors with the remote transmitter if any door is not fully closed or the key is in the ignition switch.

If you unlock the doors with the remote transmitter, but do not open any of the doors within 30 seconds, the doors automatically relock and the security system sets.

To open the trunk, push the Trunk Release button for approximately one second.

The trunk will not open if the key is in the ignition switch.

### ***Panic Mode***

Panic mode allows you to remotely activate your car's horn and exterior lights to attract attention. The horn sounds and the exterior lights flash for about 30 seconds. To activate panic mode, press and hold the PANIC button for about two seconds.

To cancel Panic mode before 30 seconds, press any button on the remote transmitter. You can also turn the ignition switch to ON (II).

Panic mode will not activate if the ignition switch is in the ON (II) position.

### ***Replacing the Battery***

When the remote transmitter's battery begins to get weak, it may take several pushes on the button to lock or unlock the doors, and the LED will not light. Replace the battery as soon as possible.

Battery type: CR2025

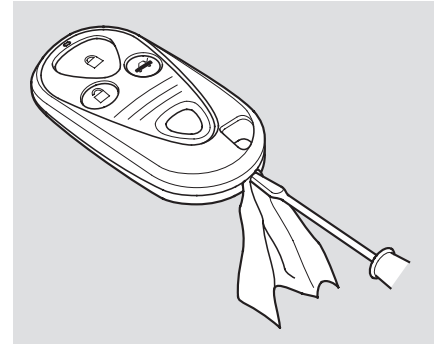

To replace the battery, place a cloth on the edge of the transmitter and remove the upper half by carefully prying on the edge with a small flat-tip screwdriver.

*CONTINUED*



## Keys and Locks

---

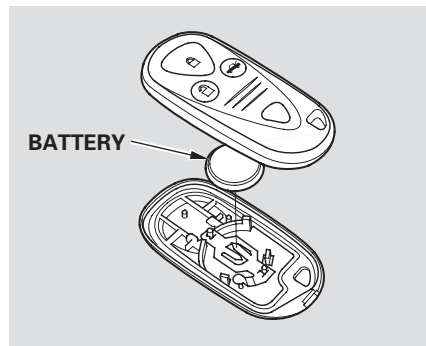

Remove the old battery and note the polarity. Make sure the polarity of the new battery is the same (– side facing up), then insert it in the transmitter.

Snap the two halves of the transmitter case back together.

*As required by the FCC:*

*This device complies with Part 15 of the FCC rules. Operation is subject to the following two conditions: (1) This device may not cause harmful interference, and (2) this device must accept any interference received, including interference that may cause undesired operation.*

*Changes or modifications not expressly approved by the party responsible for compliance could void the user's authority to operate the equipment.*

*This device complies with Industry Canada Standard RSS-210.*

*Operation is subject to the following two conditions: (1) this device may not cause interference, and (2) this device must accept any interference that may cause undesired operation of the device.*

### ***Transmitter Care***

Avoid severe shock to the transmitter, such as dropping or throwing it. Also, protect it from extreme hot or cold temperatures.

Clean the transmitter case with a soft cloth. Do not use strong cleaners or solvents that could harm the case. Immersing the transmitter in any liquid will harm the transmitter and cause it to not function properly.

If you lose a transmitter, you will need to have the replacement programmed to your car's system by your Acura dealer. Any other transmitters you have will also need to be reprogrammed.

## Childproof Door Locks

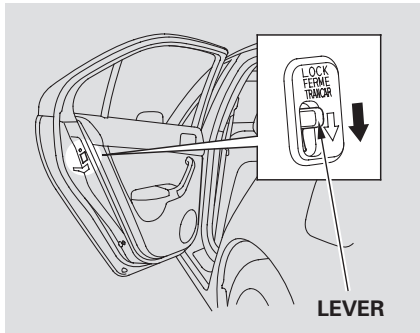

The childproof door locks are designed to prevent children seated in the rear from accidentally opening the rear doors. Each rear door has a lock lever near the edge. With the lever in the LOCK position, the door cannot be opened from the inside regardless of the position of the lock tab. To open the door, pull the lock tab up and use the outside door handle.

## Trunk

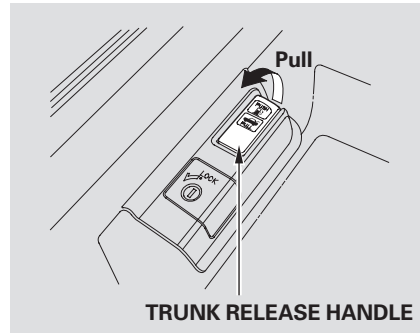

You can open the trunk in three ways:

- Pull the trunk release handle to the left of the driver's seat.
- Press and hold the trunk release button on the remote transmitter.
- If the doors are unlocked, press the trunk release button under the "A" logo on the trunk lid.

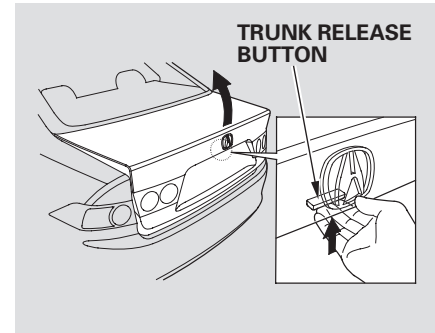

To close the trunk, press down on the trunk lid.

See page [193](#) for cargo loading and weight limit information. Keep the trunk lid closed at all times while driving to avoid damaging the lid, and to prevent exhaust gas from getting into the interior. See **Carbon Monoxide Hazard** on page [53](#).

*CONTINUED*

## Keys and Locks

---

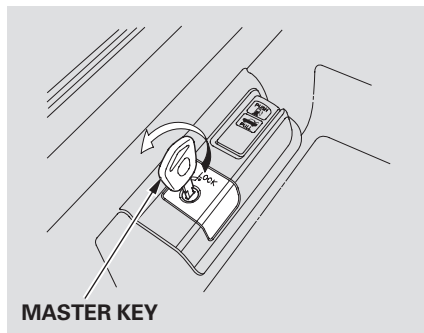

To protect items in the trunk when you need to give the key to someone else:

1. Lock the trunk release handle with the master key.
2. Give the person the valet key.

### Emergency Trunk Opener

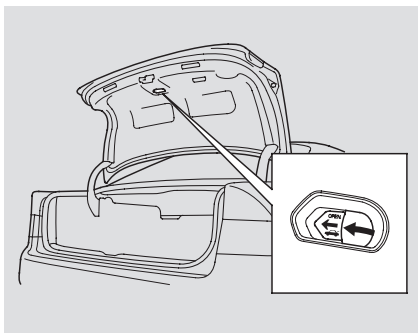

As a safety feature, your car has a release lever on the trunk latch so the trunk can be opened from the inside.

To open the trunk, push the release lever to the left.

Parents should decide if their children should be shown how to use this feature.

For more information about child safety, see page [26](#).

### Glove Box

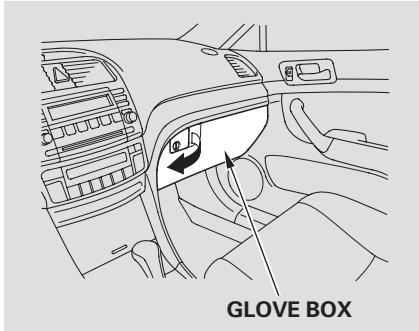

Open the glove box by pulling the handle to the left. Close it with a firm push. Lock or unlock the glove box with the master key.

The glove box light comes on when the parking lights are on.

### **⚠ WARNING**

An open glove box can cause serious injury to your passenger in a crash, even if the passenger is wearing the seat belt.

Always keep the glove box closed while driving.

## Seat Adjustments

### Driver's Seat Full Power Adjustments

See pages 13 – 14 for important safety information and warnings about how to properly position seats and seat-backs.

The two power seat adjustment switches are on the outside edge of the seat bottom. The horizontal switch adjusts the seat bottom in several directions. The short vertical switch adjusts the seat-back angle.

You can adjust the seat with the ignition switch in any position. Make all adjustments before you start driving.

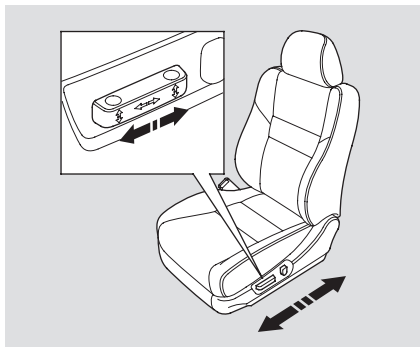

Push the horizontal switch forward or backward to move the seat forward or backward.

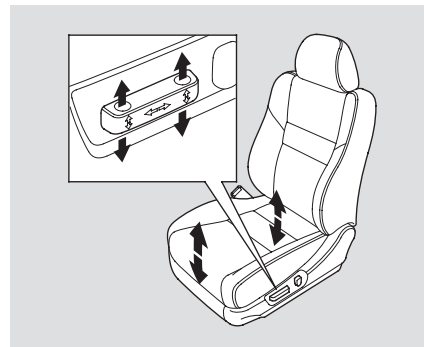

Pull up or push down on the front of the switch to move the seat bottom's front edge up or down. Pull up or push down on the rear of the switch to move the rear of the seat bottom up or down.

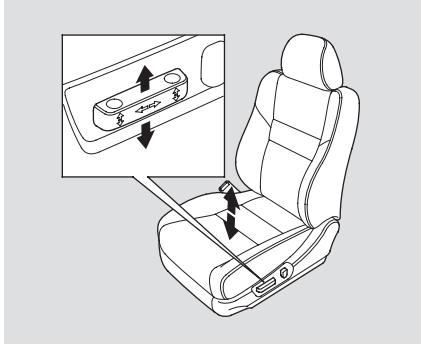

Pull the center of the horizontal switch up to raise the seat. Push it down to lower the seat.

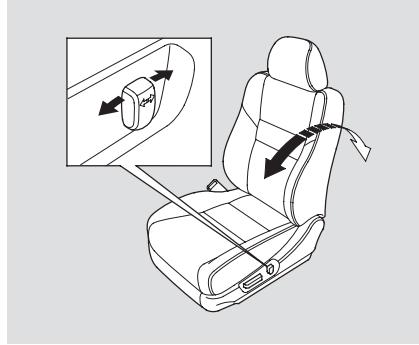

Adjust the seat-back angle by pushing the rear switch in the direction you want to move.

### Driver's Lumbar Support



Vary the lumbar support by moving the lever on the right side of the seat-back. Move the lever forward to increase support and backward to decrease it.

## Seat Adjustments

---

### Front Passenger's Seat Adjustments

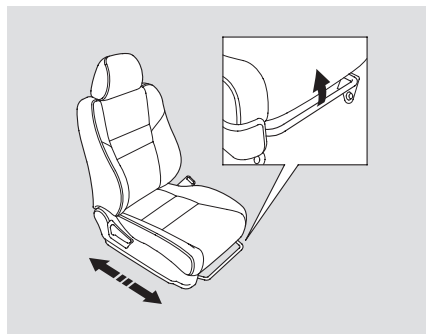

See pages 13 – 14 for important safety information and warnings about how to properly position seats and seat-backs.

To adjust the seat forward and backward, pull up on the lever under the seat cushion's front edge. Move the seat to the desired position and release the lever. Try to move the seat to make sure it is locked in position.

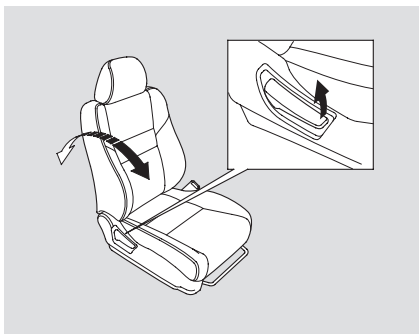

To change the angle of the seat-back, pull up on the lever on the outside of the seat bottom. Move the seat-back to the desired position and release the lever. Let the seat-back latch into the new position.

### Head Restraints

See page 15 for important safety information and a warning about how to properly position the head restraints.

Your car has adjustable head restraints on the front seats. They are also on the outside positions of the rear seat.

The head restraints help protect you and your passengers from whiplash and other injuries. They are most effective when you adjust them so the back of the occupant's head rests against the center of the restraint. A taller person should adjust the restraint as high as possible.

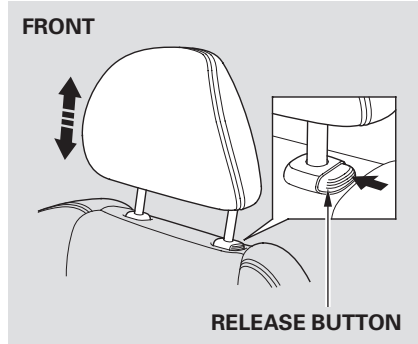

The head restraints adjust for height. You need both hands to adjust the restraint. Do not attempt to adjust it while driving. To raise it, pull upward. To lower the restraint, push the release button sideways, and push the restraint down.

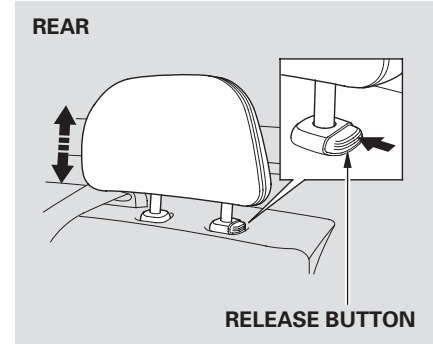

To remove a head restraint for cleaning or repair, pull it up as far as it will go. Push the release button and pull the restraint out of the seat-back.



## Seat Adjustments

### Folding Rear Seat

The back of the rear seat folds down to give you direct access to the trunk. Each side folds down separately. With only half the seat folded, you can still carry a passenger in the back seat. The seat-back can be released from inside the car or inside the trunk.

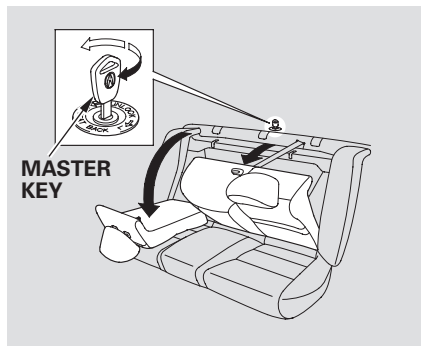

To fold down either side of the seat-back from inside the car, insert the master key in the lock on the rear shelf. To fold down the driver's side, turn the key clockwise, pull down the top of the seat-back, then release the key. To fold down the passenger's side, turn the key counterclockwise and do the same procedure.

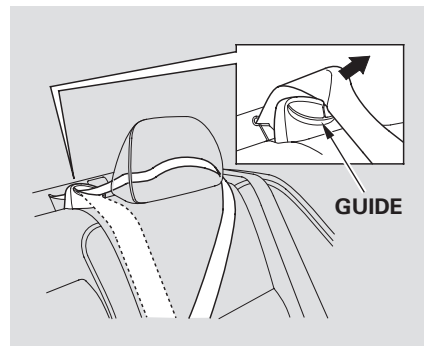

When storing cargo, you can move the rear center shoulder belt out of the way by removing the belt from the guide.

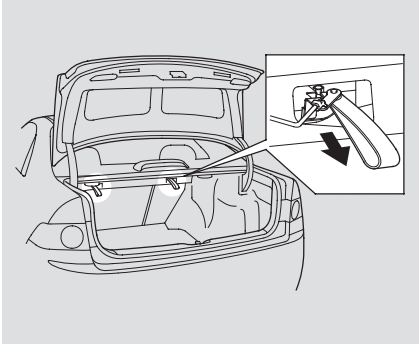

To release the seat-back from inside the trunk, pull the release under the trunk panel. Push the seat-back down, then let go of the release.

To lock the seat-back upright, push it firmly against the trunk panel. Make sure it is latched in place by pulling on the top of the seat.

Do not put any heavy items on the seat-back when it is folded.

Make sure all rear shoulder belts are positioned in front of the rear seat-back whenever the seat-back is in its upright position.

Make sure all items in the trunk, or items extending through the opening into the back seat, are secured. Loose items can fly forward and cause injury if you have to brake hard. See **Carrying Cargo** on page [193](#).

Never drive with the seat-back folded down and the trunk lid open. See **Carbon Monoxide Hazard** on page [53](#).

### Rear Seat Armrest

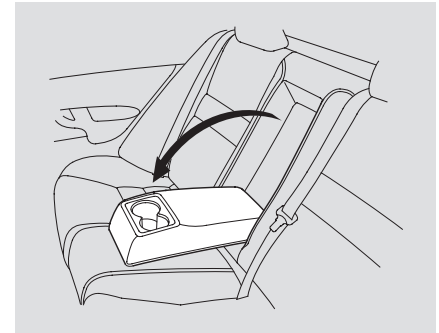

The rear seat armrest is located in the center of the rear seat. Pivot it down to use it.

## Seat Heaters

---

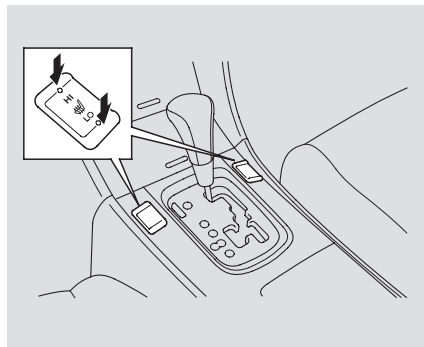

Both front seats are equipped with seat heaters. Because of the sensors for the side airbag system, there is no heater in the passenger's seat-back. The ignition switch must be ON (II) to use the heaters. Push the front of the switch, HI, to rapidly heat up the seat. After the seat reaches a comfortable temperature, select LO by pushing the back of the switch. This will keep the seat warm.

The HI or LO indicator comes on and remains lit until you turn it off by pushing the opposite side of the switch lightly.

In HI, the heater turns off when the seat gets warm, and turns back on after the seat's temperature drops. It continues to cycle as long as you leave it set on HI. The HI indicator remains lit as a reminder that you have the heater on.

In LO, the heater runs continuously. It does not cycle with temperature changes.

Follow these precautions whenever you use the seat heaters:

- Use the HI setting only to heat the seats quickly. Select the LO setting when the seats feel warm. The HI setting draws large amounts of current from the battery.
- Do not use the seat heaters, even on the LO setting, if the engine is left idling for an extended period. This can weaken the battery, causing hard starting.

Your car's windows are electrically-powered. Turn the ignition switch to ON (II) to raise or lower any window.

Each door has a switch that controls its window. To open the window, push the switch down and hold it. Release the switch when you want the window to stop. Close the window by pushing the switch up and holding it.

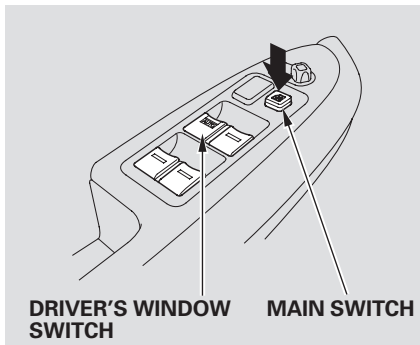

The driver's door armrest has a master power window control panel. To open any of the passenger's windows, push down on the appropriate switch and hold it until the window reaches the desired position. To close the window, pull back on the window switch. Release the switch when the window gets to the position you want.

### **⚠ WARNING**

Closing a power window on someone's hands or fingers can cause serious injury.

Make sure your passengers are away from the windows before closing them.

*CONTINUED*

## Power Windows

---

The master control panel also contains these extra features:

**AUTO** — To open the driver's window fully, push the window switch firmly down, then release it. The window automatically goes down all the way. To stop the window from going all the way down, pull back on the window switch briefly.

To close the driver's window fully, pull back the window switch firmly, then release it. The window automatically goes all the way up. To stop the window from going all the way up, push down on the window switch briefly.

To open or close the driver's window partially, push down or pull back on the window switch lightly and hold it. The window will stop when you release the switch.

The MAIN switch controls power to the passengers' windows. When you push in the MAIN switch, the passengers' windows cannot be raised or lowered. To cancel this feature, push on the switch again. The MAIN switch does not affect the driver's window. Keep the MAIN switch off when you have children in the car so they do not injure themselves by operating the windows unintentionally.

### **Auto Reverse**

If the driver's window runs into any obstacle while it is closing automatically, it will reverse direction, and then stop. To close the window, remove the obstacle, then use the window switch again.

Auto reverse stops sensing when the window is almost closed. You should always check that all passengers and objects are away from the window before closing it.

If your car's battery is disconnected or goes dead, or the driver's window fuse is removed, the AUTO function will be disabled. The power window system needs to be reset after reconnecting the battery or installing the fuse. You should do the following.

1. Start the engine. Push down on the driver's window switch until the window is fully open.
2. Pull back on the driver's window switch to close the window completely, then hold the switch for a second or two more.

If the power windows do not operate properly after resetting, have your car checked by an Acura dealer.

The power window system has a key-off delay function. The windows will still operate for up to 10 minutes after you turn off the ignition. Opening either front door cancels the delay function. You must turn the ignition switch to ON (II) again before you can raise or lower the windows.

## Power Windows

### Opening the Windows with the Remote Transmitter

You can open all of the windows from the outside with the remote transmitter.

1. Press the UNLOCK button once to unlock the driver's door.
2. Press the UNLOCK button a second time, and hold it. The passenger's doors unlock, and all four windows start to open. To stop the windows, release the button.
3. To open the windows further, press the button again.

You cannot close the windows with the remote transmitter.

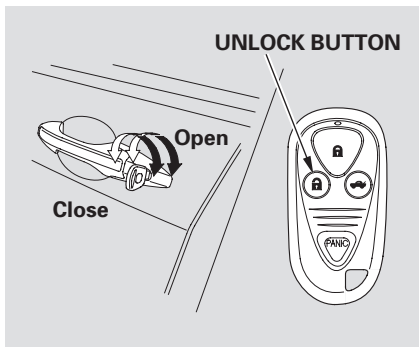

### Opening/Closing the Windows with the Key

You can open and close the windows with the key in the driver's door lock.

To open:

1. Insert the key in the driver's door lock.
2. Turn the key clockwise, then release it.

3. Turn the key clockwise again, and hold it. All four windows start to open. To stop the windows, release the key.
4. To open the windows further, turn and hold the key again (within 10 seconds).

To close:

1. Insert the key in the driver's door lock.
2. Turn the key counterclockwise, then release it.
3. Turn the key counterclockwise again, and hold it. All four windows start to close. To stop the windows, release the key.
4. To close the windows further, turn and hold the key again (within 10 seconds).

**NOTE:** If the windows stop before the desired position, repeat steps 2 and 3.

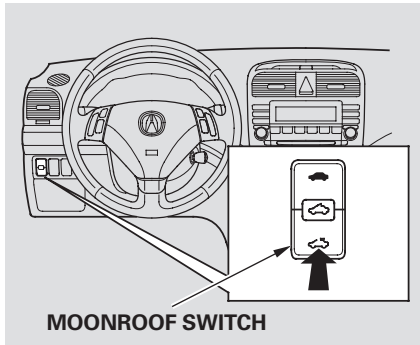

The moonroof has two positions: it can be tilted up in the back for ventilation, or it can be slid back into the roof. Use the switch under the left dashboard vent to operate the moonroof. The ignition switch must be in the ON (II) position.

To tilt up the back of the moonroof, press and hold the center button (☀️). To close the moonroof, press and hold the upper part of the switch (🚗). To open the moonroof, press and hold the lower part of the switch (☁️). Release the switch when the moonroof gets to the desired position. Make sure everyone's hands are away from the moonroof before opening or closing it.

### **⚠️ WARNING**

Opening or closing the moonroof on someone's hands or fingers can cause serious injury.

Make sure all hands and fingers are clear of the moonroof before opening or closing it.

The moonroof has a key-off delay. You can still open and close the moonroof for up to 10 minutes after you turn off the ignition. The key-off delay cancels as soon as you open either front door. You must then turn the ignition to ON (II) for the moonroof to operate.

### **NOTICE**

*If you try to open the moonroof in below-freezing temperatures, or when it is covered with snow or ice, you can damage the moonroof panel or motor.*



## Mirrors

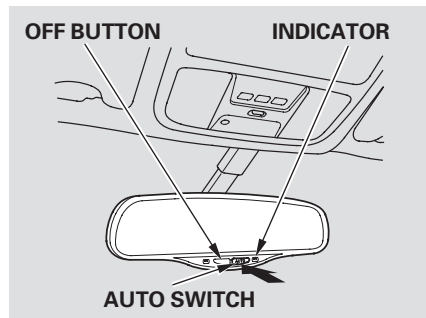

Keep the inside and outside mirrors clean and adjusted for best visibility. Be sure to adjust the mirrors before you start driving.

The inside mirror can automatically darken to reduce glare. To turn on this feature, press the AUTO button on the bottom of the mirror. The indicator comes on as a reminder. When it is on, the mirror darkens when it senses the headlights of a vehicle behind you, then returns to normal visibility when the lights are gone. Press the OFF button to turn off this feature.

### *Adjusting the Power Mirrors*

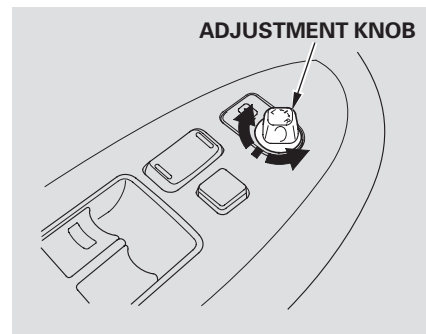

Adjust the outside mirrors with the adjustment knob on the driver's door armrest:

1. Turn the ignition switch to ON (II).
2. Turn the adjustment knob to L (driver's side) or R (passenger's side).

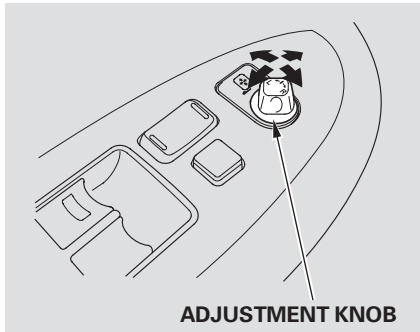

3. Push or pull the adjustment knob in the appropriate direction to move the mirror right, left, up, or down.
4. When you finish, turn the adjustment knob to the center (off) position. This turns off the adjustment knob so you can't move a mirror out of position by accidentally bumping the knob.

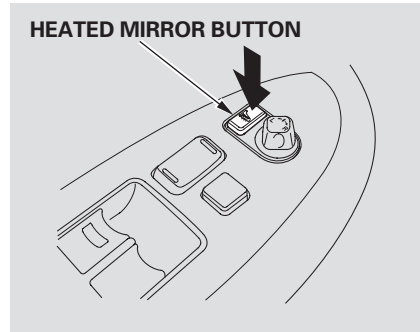

*On Canadian models*

The outside mirrors are heated to remove fog and frost. With the ignition switch in the ON (II) position, turn on the heaters by pressing the button. The light in the button comes on as a reminder. Press the button again to turn the heaters off.

## Parking Brake

---

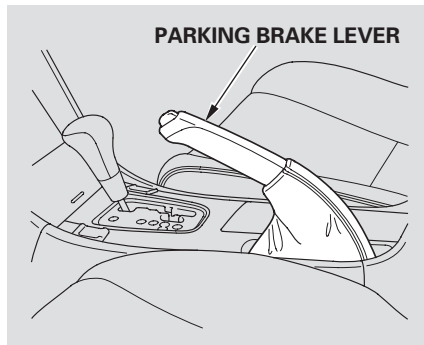

### NOTICE

*Driving the car with the parking brake applied can damage the rear brakes and hubs.*

To apply the parking brake, pull the lever up fully. To release it, pull up slightly, push the button, and lower the lever. The parking brake light on the instrument panel should go out when the parking brake is fully released with the engine running (see page [60](#)).

### Console Compartment

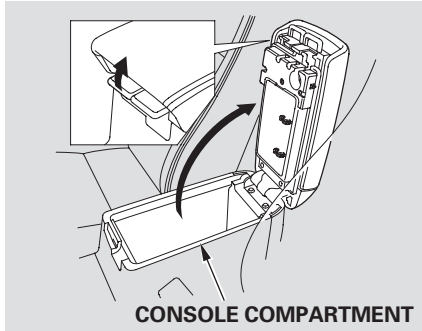

To open the console compartment, pull up on the right lever and lift the armrest.

To close, lower the armrest, and push it down until it latches.

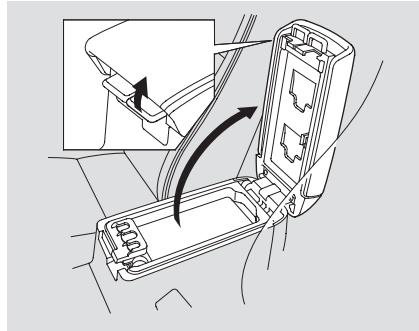

You can put small items in the tray located in the console compartment lid. To use the tray, pull up on the left lever and lift up the armrest.

The tray in the console compartment has a coin holder.

### Armrest

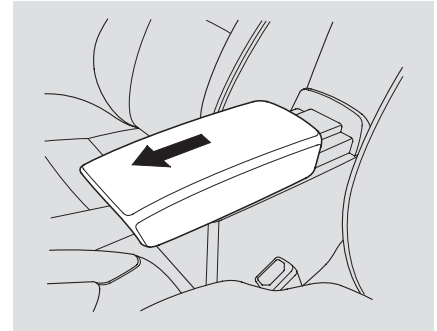

To use the console lid as an armrest, slide it to the desired position.

Make sure your passengers' hands and fingers are away from the armrest before moving it.

## Beverage Holders

---

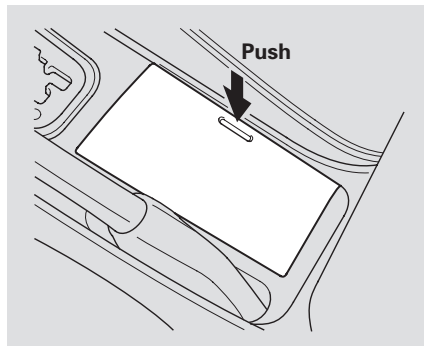

To use the front beverage holder, push on the lid. The beverage holder lid is spring-loaded and will swing open. To close it, push it down until it latches.

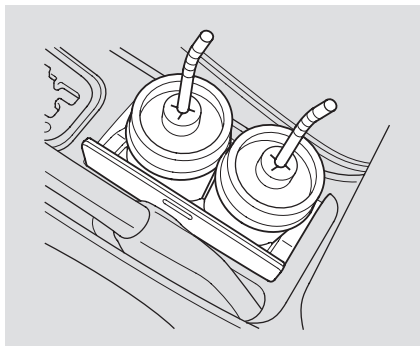

Be careful when you are using the beverage holders. A spilled liquid that is very hot can scald you or your passengers. Spilled liquids can also damage the upholstery, carpeting, and electrical components in the interior.

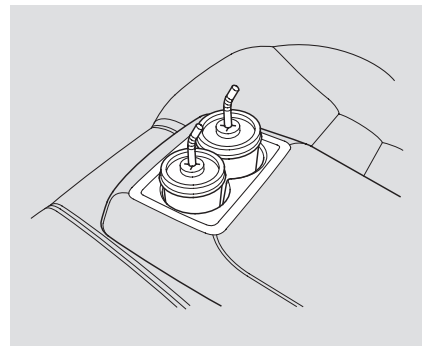

The rear seat also has a beverage holder in the center armrest. To use it, pivot the armrest down.

### Center CD Pocket

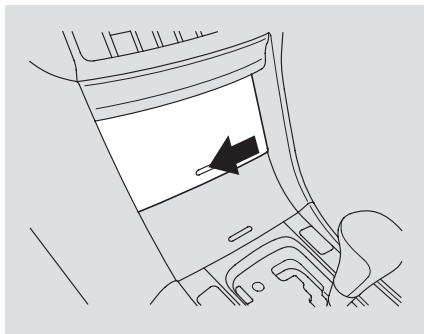

To open the center CD pocket, push down on the bottom of the lid to unlatch it. It will swing open automatically.

To close it, push the lid down until it latches.

This pocket can store up to 5 CDs.

### Utility Pocket

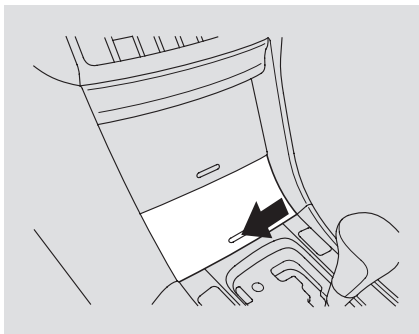

To open the utility pocket, push on the bottom of the lid. The lid will swing open automatically.

To close it, push the lid down until it latches.

The compartment cannot be used as an ashtray.

## Sun Visor, Vanity Mirror

---

### Sun Visor

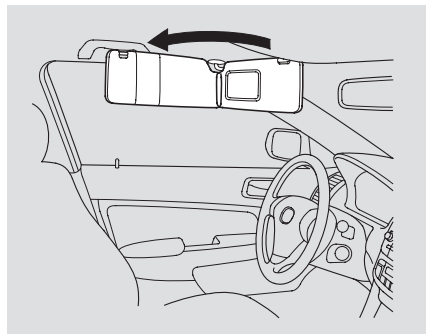

To use the sun visor, pull it down. You can also use the sun visor at the side window. Remove the support rod from the clip and swing the sun visor toward the side window.

### Vanity Mirror

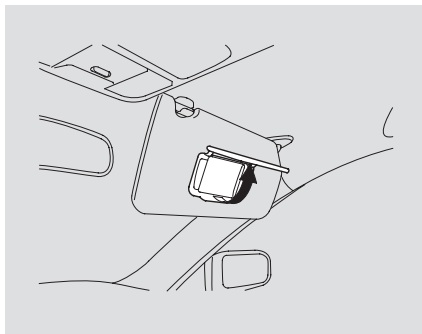

To use a vanity mirror on the back of the sun visor, pull up the cover.

The light beside the mirror comes on when you pull up the cover.

## Sunglasses Holder, Accessory Power Sockets

### Sunglasses Holder

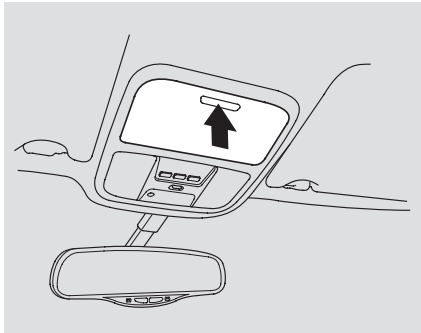

To open the sunglasses holder, push on the front edge. It will unlatch and swing down. To close it, push it until it latches. Make sure the holder is closed while you are driving.

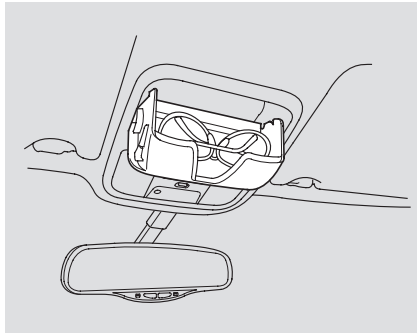

Some larger styles of sunglasses may not fit in the holder.

You may also store small items in this holder. Make sure they are small enough to let the holder close and latch, and that they are not heavy enough to cause the holder to pop open while driving.

### Accessory Power Sockets

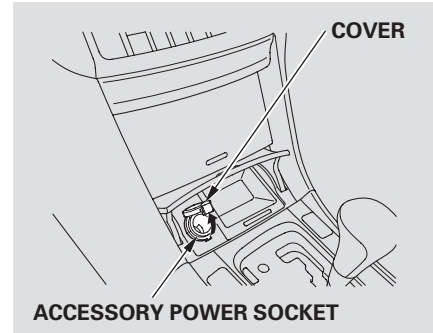

There are two accessory power sockets. One is in the front of the center console under the utility pocket lid. The other is in the center console compartment. To use an accessory power socket, the ignition switch must be in the ACCESSORY (I) or ON (II) position.

To open a socket, pull the cover up.

*CONTINUED*



## Accessory Power Sockets, Interior Lights

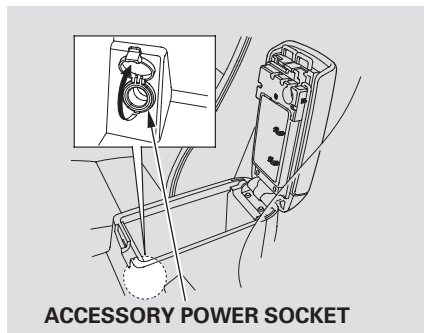

These sockets are intended to supply power for 12 volt DC accessories that are rated 120 watts or less (10 amps).

When both sockets are being used, the combined power rating of both accessories should be 120 watts or less (10 amps).

They will not power an automotive type cigarette lighter element.

### Spotlights

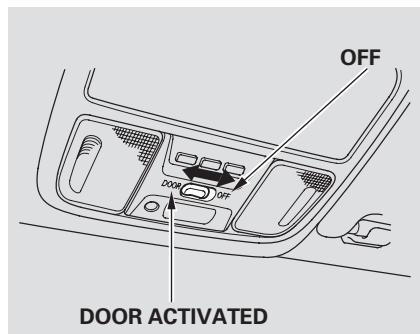

The spotlights have a three-position switch. In the OFF position, the lights do not come on. In the DOOR position, the lights come on when you open any door.

Turn on the spotlight by pushing the lens. Push the lens again to turn it off. You can use the spotlights at all times.

### Ceiling Lights

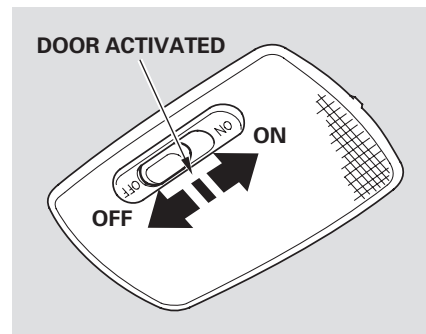

The ceiling light has a three-position switch. In the OFF position, the light does not come on. In the center position, the ceiling light comes on when you open any door.

After all doors are closed tightly, the lights dim slightly, then fade out in about 30 seconds. In the ON position, the lights stay on continuously.

The ceiling light (with the switch in the center position) also comes on when you unlock the door with the remote transmitter (see page 84 ). The light fades out after all doors are closed.

### Courtesy Light

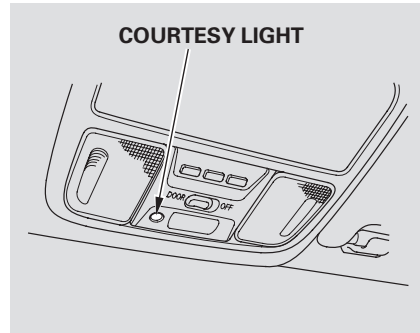

The courtesy light between the spotlights comes on when you turn the parking lights on. To adjust its brightness, turn the Select/Reset knob on the instrument panel.

### Courtesy Lights

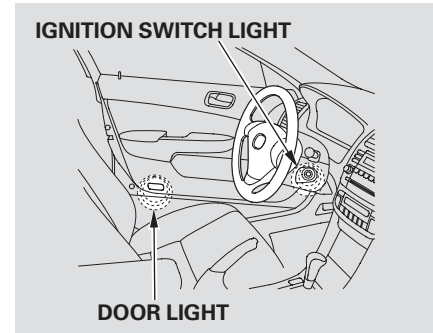

Each front door has a courtesy light. This light comes on when you open the door.

Your car also has a courtesy light in the ignition switch. This light comes on when you open the driver's door. It remains on for several seconds after the door is closed.



## Comfort and Convenience Features

---

Climate Control System.....	114	Adjusting the Sound .....	152
<i>Without Navigation System</i>		Digital Clock .....	153
Fully-automatic Operation .....	115	Radio Frequencies .....	154
Semi-automatic Operation .....	116	Radio Reception .....	154
<i>With Navigation System</i>		Operating the CD Changer .....	156
Fully-automatic Operation .....	121	CD Changer Error	
Semi-automatic Operation .....	122	Indications .....	164
Sunlight Sensor/ Temperature Sensor .....	128	Protecting Compact Discs .....	165
Audio System .....	129	Operating the Cassette Player .....	166
<i>Without Navigation System</i>		Tape Search Functions .....	168
Operating the Radio .....	130	Caring for the Cassette Player .....	170
Adjusting the Sound.....	134	Remote Audio Controls .....	171
Digital Clock.....	135	Theft Protection .....	172
Operating the CD Changer .....	136	Security System .....	173
Protecting Compact Discs.....	142	Cruise Control.....	174
CD Changer Error		HomeLink Wireless Control System.....	177
Indications .....	143		
Operating the Cassette Player .....	144		
Tape Search Functions .....	146		
Caring for the Cassette Player .....	147		
Audio System .....	148		
<i>With Navigation System</i>			
Operating the Radio .....	149		

## Climate Control System

The automatic climate control system in your Acura picks the proper combination of air conditioning, heating, and ventilation to maintain the interior temperature you select. The system also adjusts the fan speed and air flow levels.

The direction of air flow from the vents in the center and each side of the dashboard is adjustable.

The climate control system draws air through the exterior vents at the bottom of the windshield. Keep these vents clear of leaves and other debris.

For the climate control system to provide heating and cooling, the engine must be running.

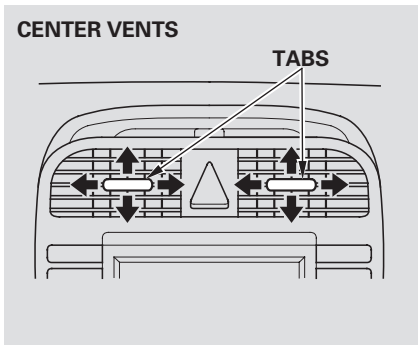

To adjust the air flow from a vent, move the tab up-and-down and side-to-side.

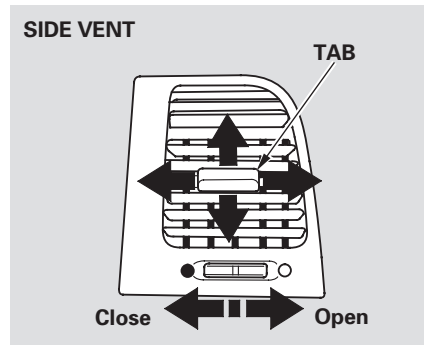

The side vents can be opened and closed with the dials underneath them.

## ***Without Navigation System*** **Fully-automatic Operation**

To put the Automatic Climate Control in fully-automatic mode, press the AUTO button, then set the desired temperature by pressing “▲” or “▼” on the driver’s side temperature control bar. You will see AUTO in the system’s display.

The system automatically selects the proper mix of conditioned and/or heated air that will, as quickly as possible, raise or lower the interior temperature from its current level to the set temperature.

When you set the temperature to its lower limit “Lo” or its upper limit “Hi”, the system runs at full cooling or heating only. It does not regulate the interior temperature.

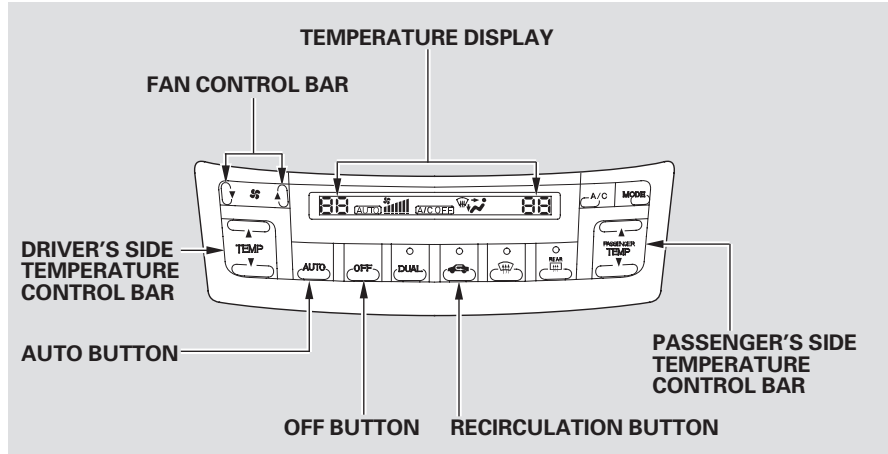

In cold weather, the fan will not come on automatically until the car has been driven for a short time and the heater starts to develop warm air.

Pressing the OFF button shuts the climate control system completely off. Keep the system completely off only for short periods. To keep stale air and mustiness from collecting, you should have the fan running at all times.

## Climate Control System

### Semi-automatic Operation

You can manually select various functions of the Climate Control system when it is in fully automatic mode. All other features remain automatically controlled. Making any manual selection causes the word AUTO in the display to go out.

### Air Conditioning (A/C) Button

Press the A/C button to turn the air conditioning on and off. You will see A/C ON or A/C OFF in the display.

When you turn the A/C off, the system cannot regulate the inside temperature if you set the temperature below the outside temperature. With the A/C off, use the driver's side temperature control bar to adjust the temperature of the air flow to a comfortable setting.

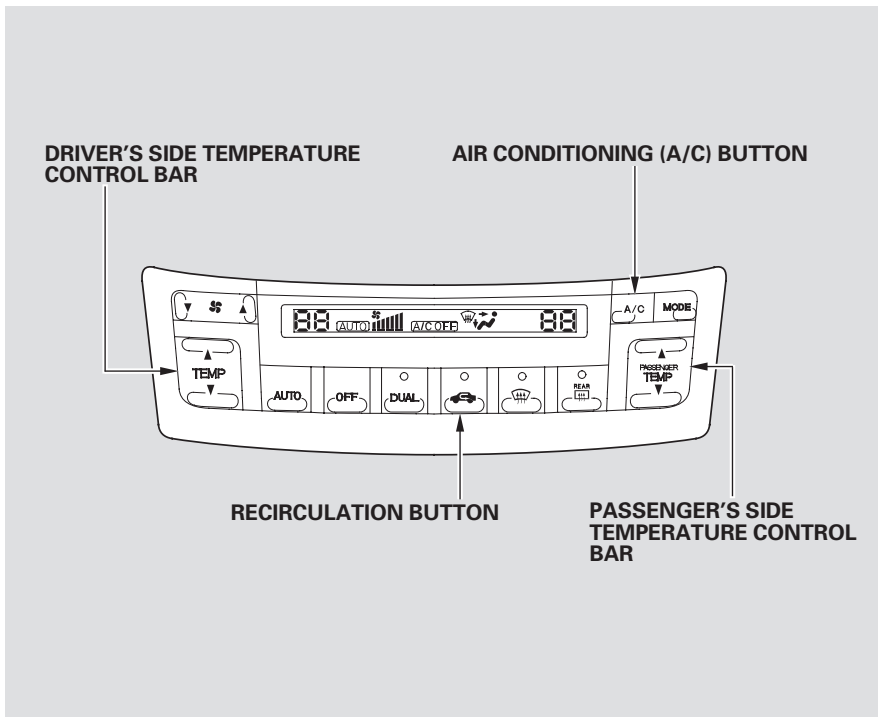

## **Recirculation Button**

This button controls the source of air going into the system. When the indicator in this button is lit, air from the car's interior is sent through the system again (Recirculation mode). When the indicator is off, air is brought in from outside the car (Fresh Air mode). You can, for example, manually put the system in recirculation mode when driving through an area of smoke or fumes.

## **Fan Control Bar**

You can manually select the fan speed by pressing the fan control bar: ▲ to increase the fan's speed, or ▼ to decrease the fan's speed.

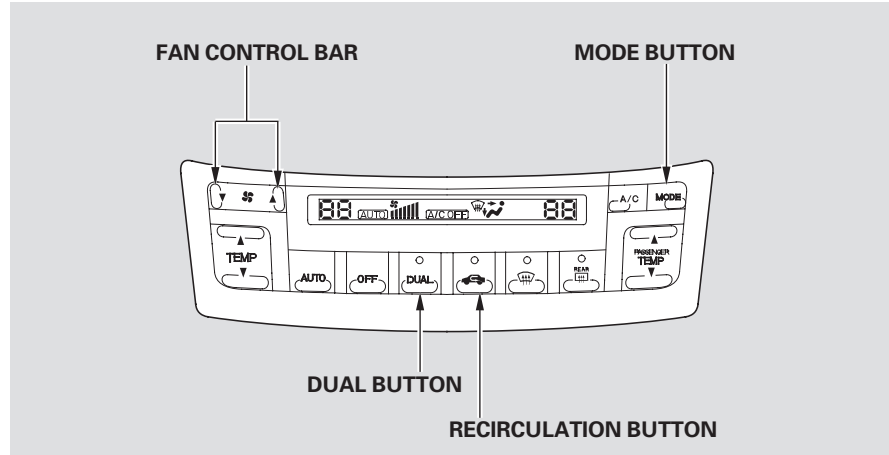

## **Mode Button**

Use the MODE button to select the vents the air flows from. Some air will flow from the dashboard corner vents in all modes; you can turn it off with the dial below each vent. Each time you press the MODE button, the display shows the mode selected. Press the button four times to see all

the modes.

## **Dual Button**

Press the DUAL button to select dual temperature control mode (see page 120).

*CONTINUED*



## Climate Control System

---

 The main air flow is divided between the floor vents and defroster vents at the base of the windshield.

 The main air flow comes from the floor vents.

 The main air flow is divided between the dashboard vents and the floor vents.

 The main air flow comes from the dashboard vents.

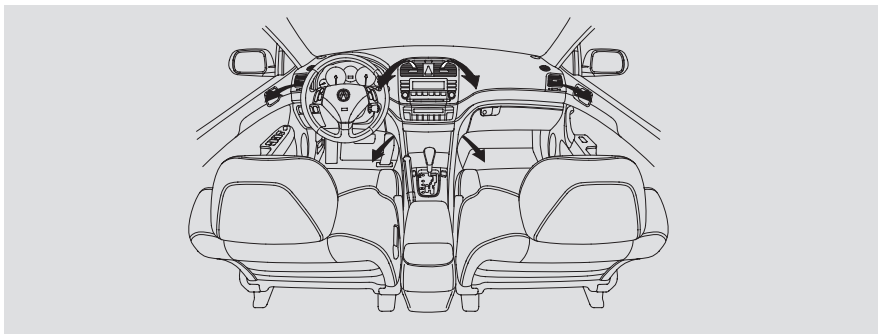
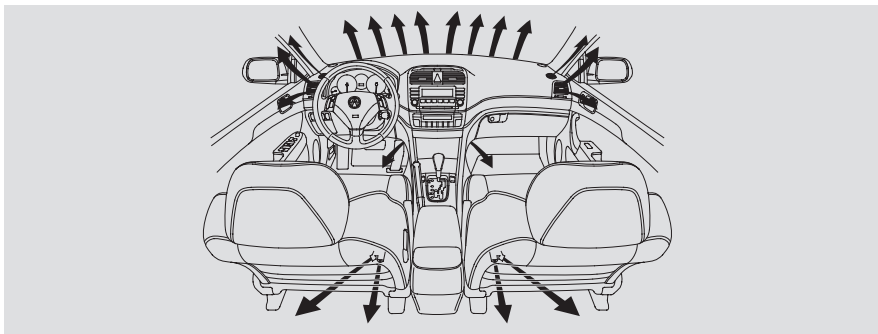

## Windshield Defroster Button

The  button directs the main air flow to the windshield for faster defrosting. It also overrides any MODE selection you may have made.

When you select , the A/C turns on automatically and the system selects Fresh Air mode. For faster defrosting, manually set the fan speed to high. You can also increase air flow to the windshield by closing the side vents in the dashboard.

When you turn off  by pressing the button again, the system returns to its former settings.

## Rear Window Defogger Button

This button turns the rear window defogger on and off (see page 75 ).

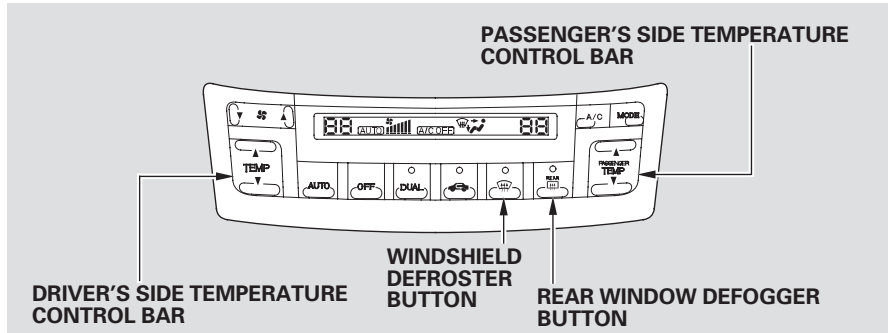
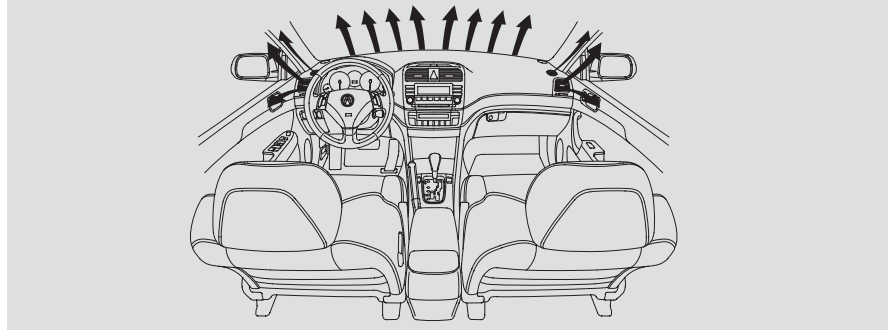

## Climate Control System

### Dual Temperature Control

Your car is equipped with two temperature control bars, one for the driver, and one for the passenger. The driver's side and the passenger's side can be controlled independently by adjusting these bars when the green indicator in the DUAL button is lit.

### Temperature Control Bars

Push the fan, the A/C, the AUTO, or the  button, and the set temperatures appear in the display. When the indicator in the DUAL button is off, you can adjust both sides to the same temperature with the driver's side control bar.

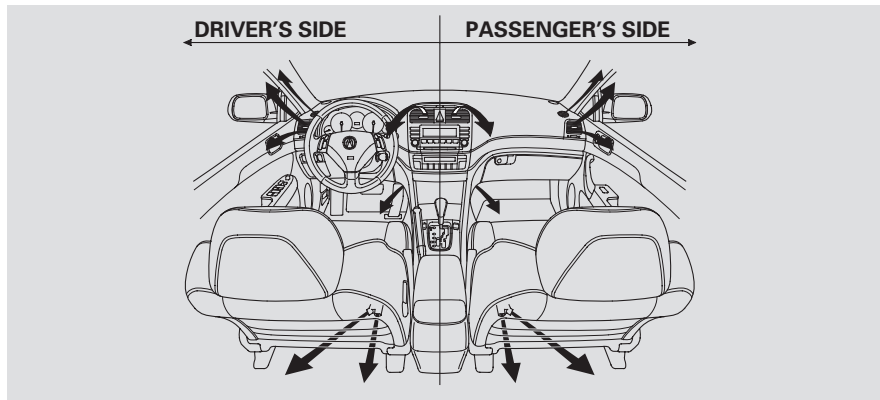

To set the driver's side temperature to a different value than the passenger's, press the DUAL button, then press "▲" or "▼" on the driver's side control bar. To set the passenger's side to a different value than the driver's side, press "▲" or "▼" on the passenger's side control bar (see page 115). You can adjust the passenger's side without pressing the DUAL button first.

When you set the temperature to its lower limit or its upper limit, it will be displayed as "Lo" or "Hi".

## *With Navigation System*

### **Fully-automatic Operation**

To put the Automatic Climate Control in fully-automatic mode, press the AUTO button. The indicator in the button will light. Then set the desired temperature by pressing “▲” or “▼” on the driver’s side temperature control bar.

The system automatically selects the proper mix of conditioned and/or heated air that will, as quickly as possible, raise or lower the interior temperature from its current level to the set temperature.

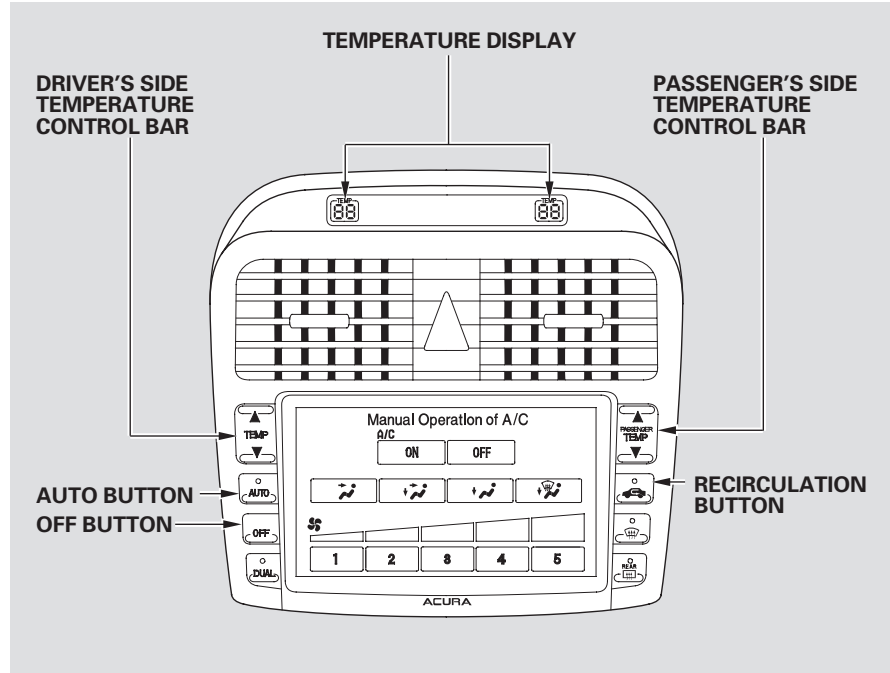

*CONTINUED*

## Climate Control System

---

When you set the temperature to its lower limit “Lo” or its upper limit “Hi”, the system runs at full cooling or heating only. It does not regulate the interior temperature. When the temperature is set between the lower and upper limits, the system regulates the interior temperature to the set value.

In cold weather, the fan will not come on automatically until the car has been driven for a short time and the heater starts to develop warm air.

Pressing the OFF button shuts the climate control system completely off. No air flow can cause the windows to fog up. It is recommended that you keep the fan on at all times so stale air and moisture do not build up in the interior and cause fogging.

### **Semi-automatic Operation**

You can manually select various functions of the Climate Control system when it is in fully automatic mode. All other features remain automatically controlled. Some of these functions appear in the Navigation System display. Press the A/C button under the display to show these functions. Making any manual selection causes the indicator in the AUTO button to go out.

## ***Air Conditioning (A/C) Icons***

Touching “ON” or “OFF” in the display turns the air conditioning on and off. You will see A/C ON or A/C OFF in the display.

When you turn the A/C off, the system cannot regulate the inside temperature if you set the temperature control bars below the outside temperature. With the A/C off, use the temperature control bars to adjust the temperature of the air flow to a comfortable setting.

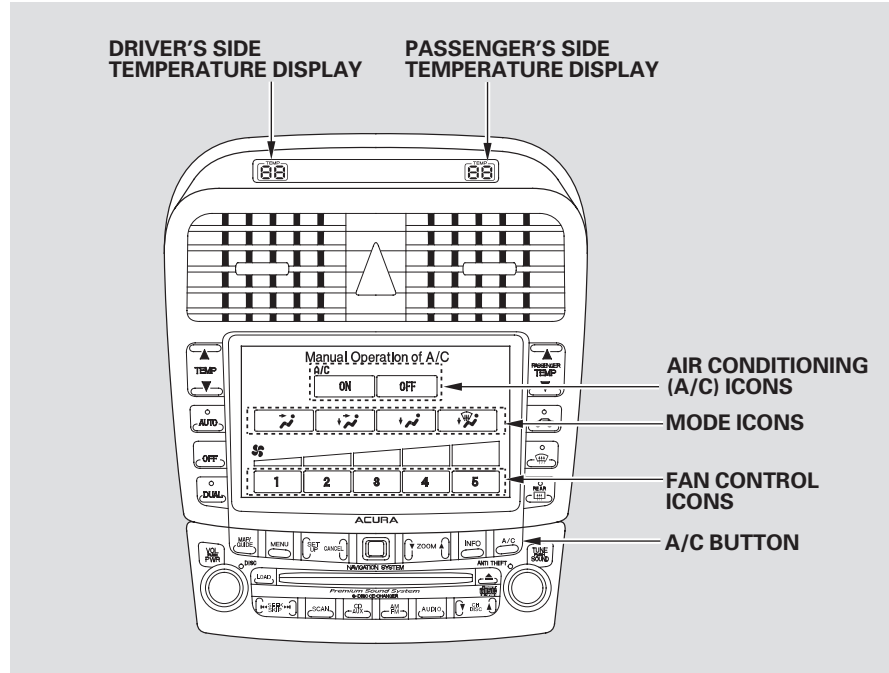

*CONTINUED*

## Climate Control System

### *Mode Icons*

Use the MODE icons in the A/C display to select the vents the air flows from. Some air will flow from the dashboard corner vents and the side vents in all modes.

 The main air flow is divided between the floor vents and defroster vents at the base of the windshield.

 The main air flow comes from the floor vents.

 The main air flow is divided between the dashboard vents and the floor vents.

 The main air flow comes from the dashboard vents.

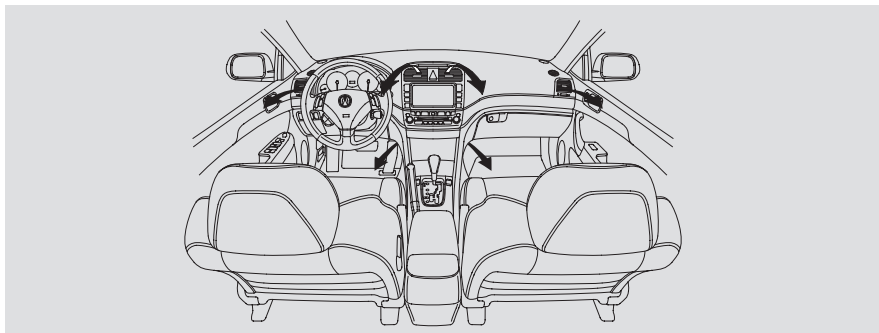
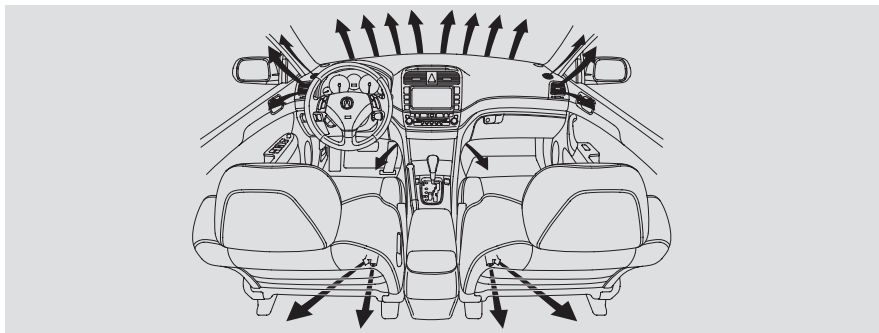

## ***Fan Control Icons***

You can manually select the fan speed by touching any of the fan control icons on the display.

## ***Recirculation Button***

This button controls the source of air going into the system. When the indicator in this button is lit, air from the car's interior is sent through the system again (Recirculation mode). When the indicator is off, air is brought in from outside the car (Fresh Air mode).

You can, for example, manually put the system in recirculation mode when driving through an area of smoke or fumes.

## ***Dual Button***

Press the DUAL button to select dual temperature control mode (see page 127).

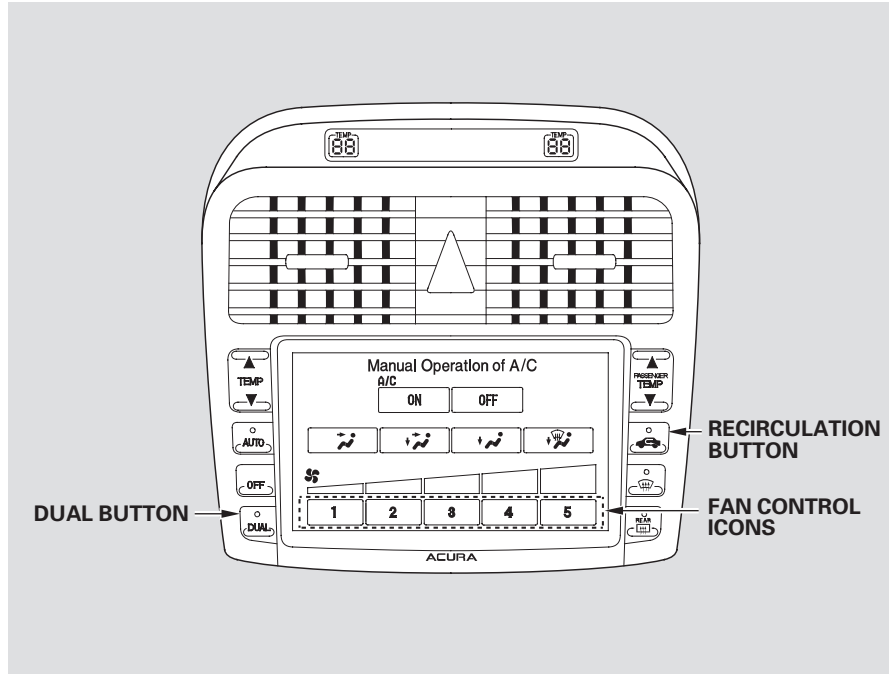



CONTINUED



## Climate Control System

### Windshield Defroster Button

The  button directs the main air flow to the windshield for faster defrosting. It also overrides any MODE selection you may have made.

When you select , the A/C turns on automatically and the system selects Fresh Air mode. For faster defrosting, manually set the fan speed to high. You can also increase air flow to the windshield by closing the side vents in the dashboard.

When you turn off  by pressing the button again, the system returns to its former settings.

### Rear Window Defogger Button

This button turns the rear window defogger on and off (see page 75 ).

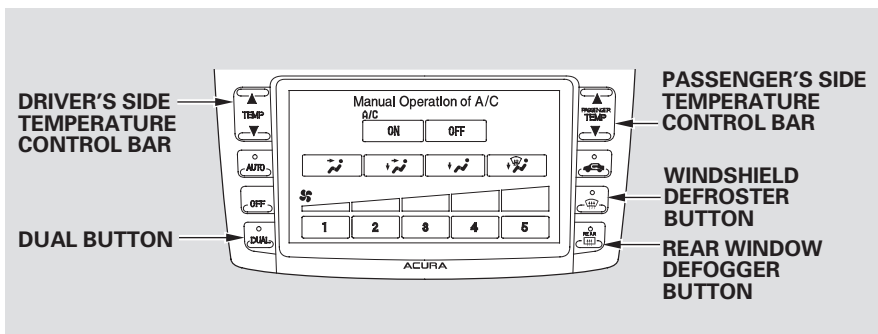
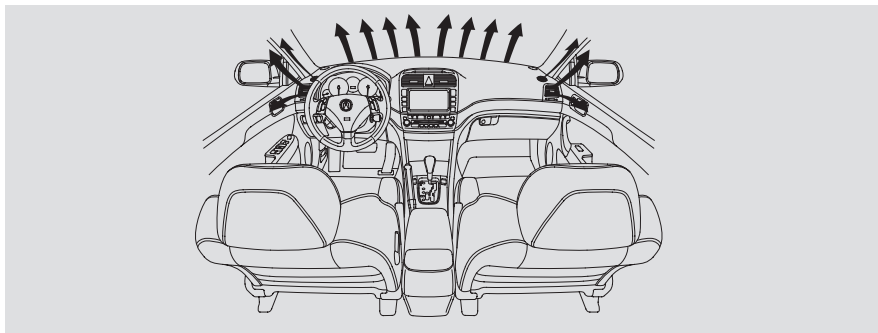

## Dual Temperature Control

Your car has two temperature control bars on the climate control panel, one for the driver and one for the passenger. The driver's and passenger's sides can be controlled independently by pushing these bars when the green indicator in the DUAL button is lit.

### Temperature Control Bars

Push AUTO or  and the set temperatures appear in the display. When the indicator in the DUAL button is off, you can adjust both sides to the same temperature by pressing “▲” or “▼” on the driver's side temperature control bar.

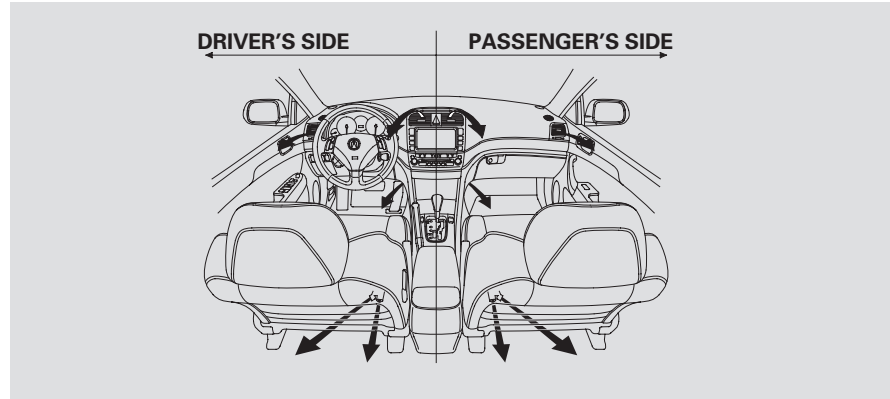

To set the driver's side temperature to a different value than the passenger's, press the DUAL button, then press “▲” or “▼” on the driver's side temperature control bar. To set the passenger's side to a different value than the driver's, press “▲” or “▼” on the passenger's side temperature control bar. You can adjust the passenger's side without pressing the DUAL button first.

When you set the temperature to its lower limit or its upper limit, it will be displayed as “Lo” or “Hi”.

## Climate Control System

---

### Sunlight Sensor/Temperature Sensor

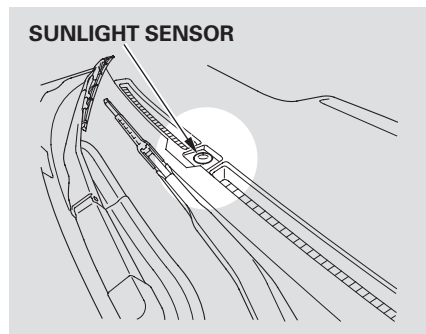

The climate control system has two sensors. A sunlight sensor is located in the top of the dashboard and a temperature sensor is next to the steering column. Do not cover the sensors or spill any liquid on them.

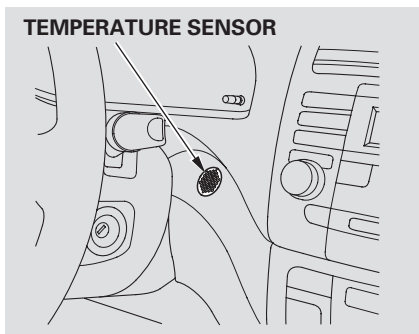



## Audio System

---

### Operating the Radio

The ignition switch must be in the ACCESSORY (I) or ON (II) position to operate the audio system. Turn the system on by pressing the PWR/VOL knob or the AM or FM button. Adjust the volume by turning the knob.

The band and frequency that the radio was last tuned to is displayed. To change bands, press the AM/FM button. On the FM band, ST will be displayed if the station is broadcasting in stereo. Stereo reproduction on AM is not available.

You can use any of five methods to find radio stations on the selected band: TUNE, SEEK, SCAN, AUTO SELECT, and the preset buttons.

**TUNE** — Use the TUNE knob to tune the radio to a desired frequency. Turn the TUNE knob to the right to tune to a higher frequency, or to the left to tune to a lower frequency.

**SEEK** — The SEEK function searches the band for a station with a strong signal. To activate it, press the SEEK bar ( ◀◀ or ▶▶ ), then release it. Depending on which side of the SEEK bar you press, the system scans upward or downward from the current frequency. It stops when it finds a station with a strong signal.

**SCAN** — The SCAN function samples all the stations with strong signals on the selected band. To activate it, press the SCAN button, then release it. You will see SCAN in the display. The system will scan up the band for a station with a strong signal. When it finds one, it will stop and play that station for about 5 seconds. If you do nothing, the system will then scan for the next strong station and play that for 5 seconds. When it plays a station that you want to continue listening to, press the SCAN button again.

**Preset** — You can store the frequencies of your favorite radio stations in the six preset buttons. Each button will store one frequency on the AM band, and two frequencies on the FM band.

To store a frequency:

1. Select the desired band, AM or FM. FM1 and FM2 let you store two frequencies with each preset button.
2. Use the TUNE, SEEK, or SCAN function to tune the radio to a desired station.
3. Pick the preset button you want for that station. Press the button and hold it until you hear a beep.
4. Repeat steps 1 to 3 to store a total of six stations on AM and twelve on FM.

Once a station's frequency is stored, simply press and release the proper preset button to tune to it.

The preset frequencies will be lost if your car's battery goes dead, is disconnected, or the radio fuse is removed.

## Audio System

**AUTO SELECT** — If you are traveling far from home and can no longer receive the stations you preset, you can use the Auto Select feature to find stations in the local area.

To activate Auto Select, press the A. SEL button. A. SEL will flash in the display, and the system will go into scan mode for several seconds. It automatically scans both bands, looking for stations with strong signals. It stores the frequencies of six AM stations and twelve FM stations in the preset buttons. You can then use the preset buttons to select those stations.

If you are in a remote area, Auto Select may not find six strong AM stations or twelve strong FM stations. If this happens, you will see a “0” displayed when you press any preset button that does not have a station stored.

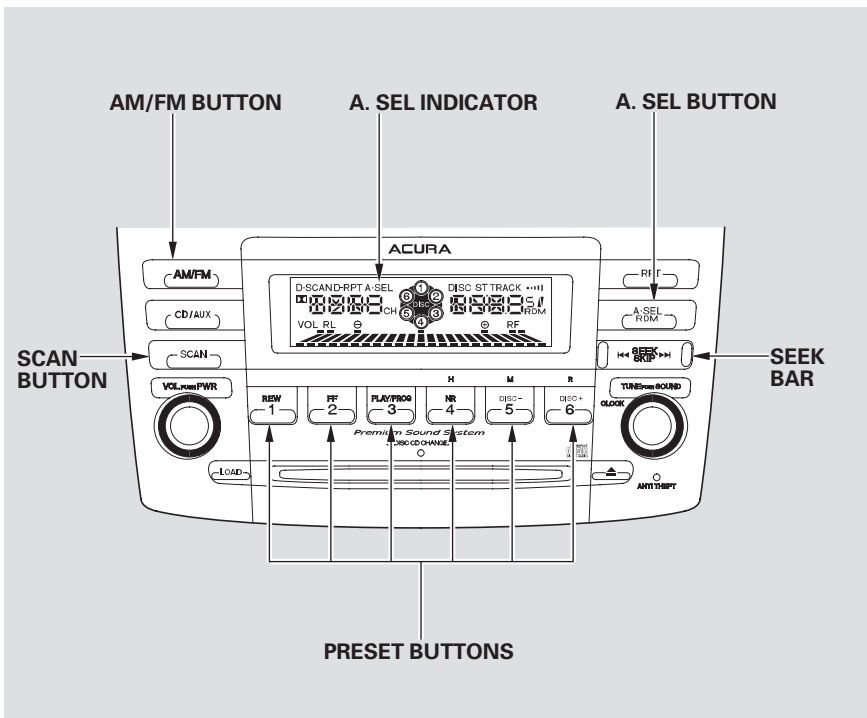

If you do not like the stations Auto Select has stored, you can store other frequencies in the preset buttons. Use the TUNE, SEEK, or SCAN function to find the desired frequencies, then store them in the selected preset buttons as described previously.

Auto Select does not erase the frequencies that you set previously. When you return home, turn off Auto Select by pressing the A. SEL button. The preset buttons will then select the frequencies you originally set.

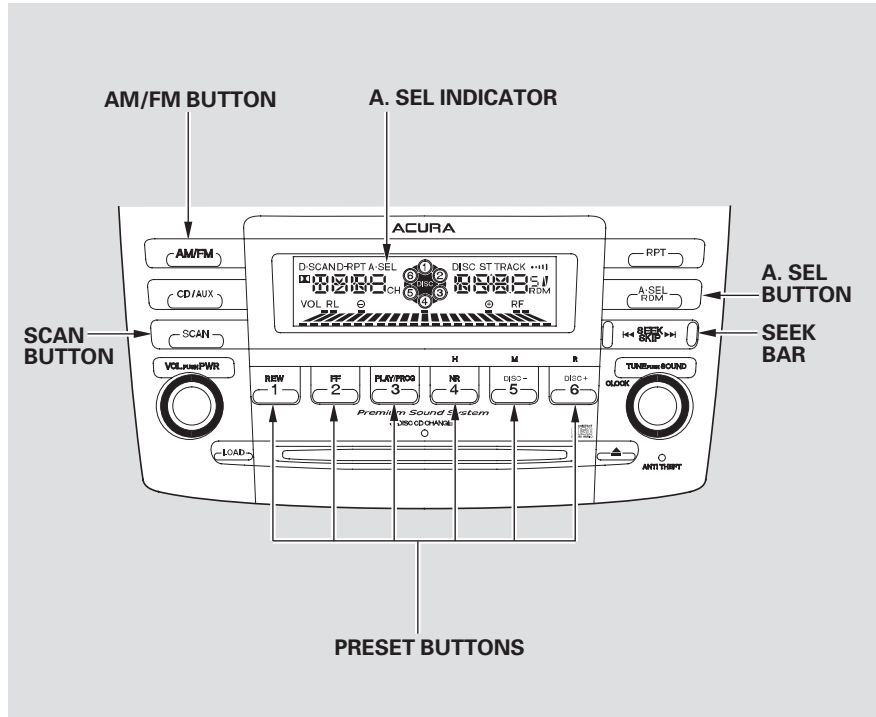



## Audio System

### Adjusting the Sound

Bass, Treble, Balance, and Fader are each adjustable. You select which of these you want to adjust by pressing the TUNE/SOUND knob. The mode changes from BAS to TRE to FAD to BAL, and then back to the selected audio mode, each time you press the TUNE/SOUND knob.

**Treble/Bass** — Use these modes to adjust the tone to your liking. Select TRE or BAS by pressing the TUNE/SOUND knob. Adjust the desired mode by turning the knob.

The displayed number shows you the current setting.

When the adjustment level reaches the center, you will see “”.

**Balance/Fader** — These two modes adjust the strength of the sound coming from each speaker. BAL adjusts the side-to-side strength, while FAD adjusts the front-to-back strength.

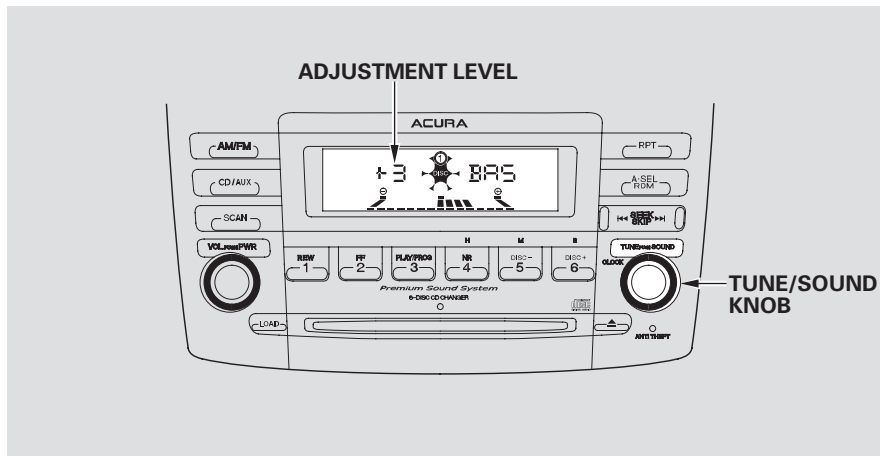

Select BAL or FAD by pressing the TUNE/SOUND knob. Adjust the Balance or Fader to your liking by turning the knob.

The displayed number shows you the current setting.

When the adjustment level reaches the center, you will see “”.

The system will automatically return the display to the selected audio mode about 5 seconds after you stop adjusting a mode with the TUNE/SOUND knob.

### Radio Frequencies and Reception

For information, see page [154](#).

## Digital Clock

The digital clock between the center air vents displays the time when the ignition switch is in the ACCESSORY (I) or ON (II) position. You can set the time with the controls on the audio control panel.

To set the time, press and hold the TUNE/SOUND knob until the audio system beeps and the clock flashes.

To set the hour, press and hold the H (Preset 4) button until the numbers advance to the desired time.

To set the minute, press and hold the M (Preset 5) button until the numbers advance to the desired time.

When you are finished, press the TUNE/SOUND knob again.

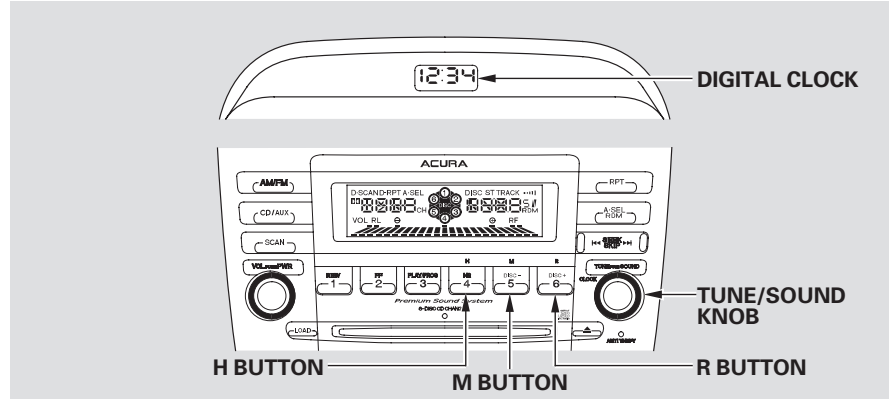

You can use the R (Preset 6) button to quickly set the time to the nearest hour. Press R while pressing the TUNE/SOUND knob. If the displayed time is before the half hour, pressing R sets the clock back to the previous hour. If the displayed time is after the half hour, pressing R sets the clock forward to the beginning of the next hour.

For example:

- 1:06 would RESET to 1:00.
- 1:52 would RESET to 2:00.

If your car's battery is disconnected or goes dead, the time setting will be lost. To set the time again, follow the setting procedure.

## Audio System

### Operating the CD Changer

Your Acura's audio system has an in-dash CD changer that holds up to six discs, providing several hours of continuous entertainment. You operate this CD changer with the same controls used for the radio.

To load CDs or operate the CD changer, the ignition switch must be in the ACCESSORY (I) or ON (II) position.

Load and play only standard round discs. Odd-shaped CDs may jam in the drive or cause other problems. You cannot load and play 3-inch (8-cm) discs in this system.

For best results when using CD-R discs, use only high quality discs labeled for audio use. When recording a CD-R, the recording must be closed in order for the disc to be used by CD players. CD-RW discs will not work in this unit.

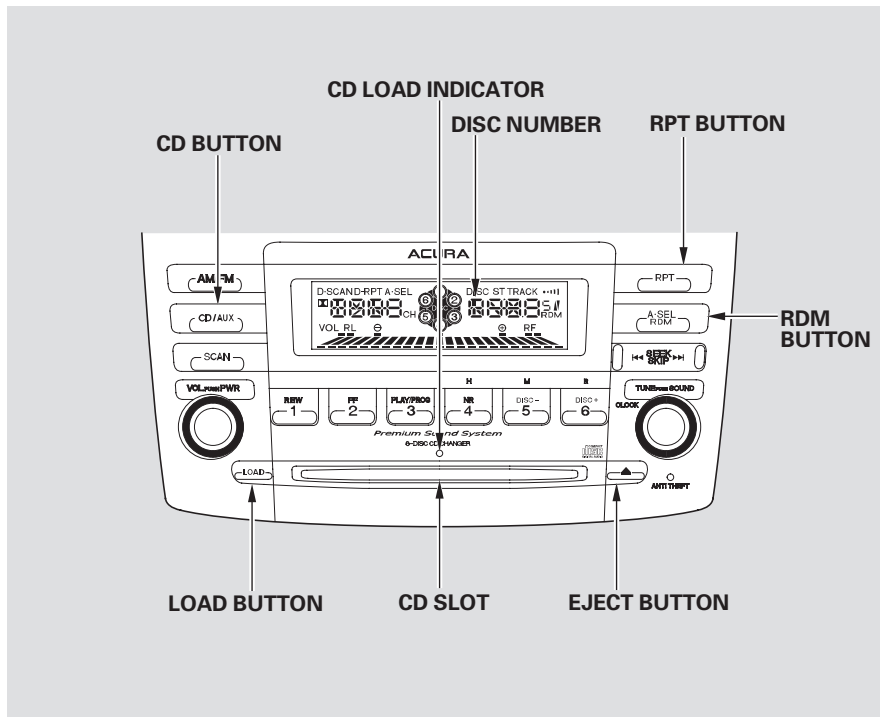

### *Loading CDs in the Changer*

To load multiple CDs:

1. Press and hold the LOAD button until you hear a beep and see "LOAD" in the display, then release the button.
2. On the center of the display, the disc number for an empty position will begin blinking and the green CD load indicator will come on.
3. Insert a disc into the CD slot. Insert it only about halfway; the drive will pull it in the rest of the way. You will see "BUSY" in the display. The CD load indicator turns red and blinks as the CD is loaded.

4. When the CD load indicator turns green and "LOAD" appears in the display, insert the next disc into the CD slot.
5. Repeat this until all six positions are loaded. The system will then begin playing the last CD loaded.

If you are not loading CDs into all six positions, the system will begin playing the last CD loaded.

If you stop loading CDs before all six positions are filled, and you do not press the LOAD button, the system will wait for 10 seconds, then stop the load operation and begin playing the last CD loaded.

To load a single CD:

1. Press and release the LOAD button.
2. The disc number for an empty position starts to blink and the green CD load indicator comes on. When you see "LOAD" in the display, insert the disc into the CD slot. Insert it only about halfway; the drive will pull it in the rest of the way.
3. The system will load the CD, and begin playing it.

*CONTINUED*

## Audio System

If you press the LOAD button while a CD is playing, the system will stop playing that CD and start the loading sequence. It will then play the CD just loaded.

You can also load a CD into an empty position while a CD is playing by pressing the appropriate preset button. Select an empty position (the disc number indicator is off), and press the preset button for that position (1 to 6). The system will stop playing the current CD and start the loading sequence. It will then play the CD just loaded.

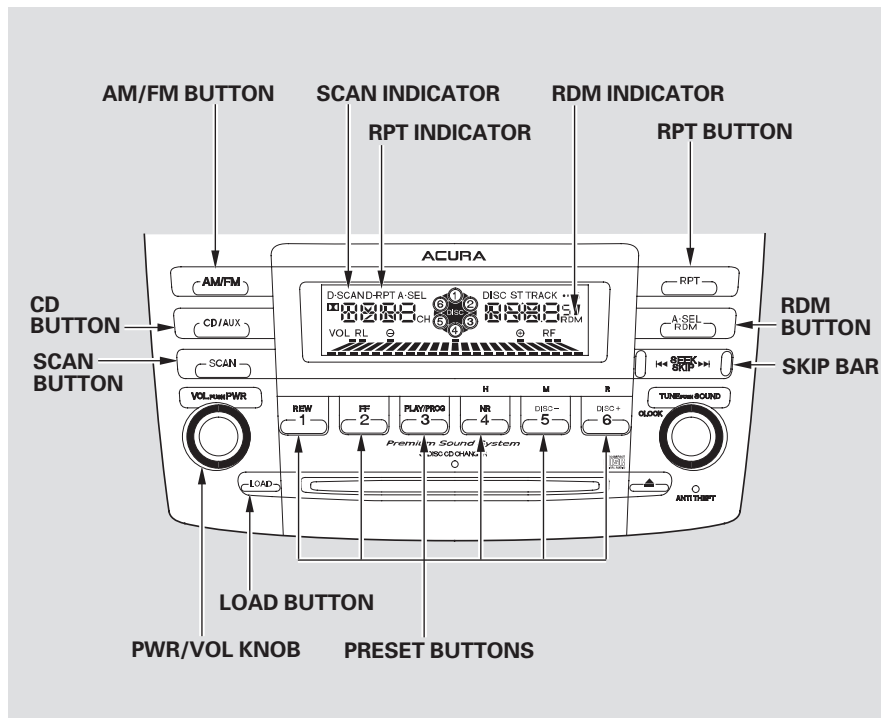

### *Operation*

Select the CD changer by pressing the CD button. You will see “CD” in the display. The system will begin playing the last selected disc in the CD changer. You will see the disc and track numbers displayed.

When that disc ends, the next disc in the CD changer is loaded and played. After the last disc finishes, the system returns to disc one.

To select a different disc, press the appropriate Preset button (1 – 6). If you select an empty position in the CD changer, the system will go into the loading sequence (see page 158).

You can use the SKIP bar while a disc is playing to select passages and change tracks.

To move rapidly within a track, press and hold the left or right side of the SKIP bar. You will hear a beep and the system will continue to move. Press ►► to move forward, or ◄◄ to move backward. Release the bar when the system reaches the point you want.

Each time you press ►► and release it, the system skips forward to the beginning of the next track. Press and release ◄◄ to skip backward to the beginning of the current track. Press and release it again to skip to the beginning of the previous track.

**SCAN** — This feature, when activated, samples all the tracks on the selected disc in the order they are recorded on the CD. To activate the Scan feature, select the Scan mode by pressing the SCAN button. You will see SCAN in the display. The system will then play the first track for about 10 seconds. If you do nothing, the system will then play the following tracks for 10 seconds each. When it plays a track that you want to continue listening to, press the SCAN button again.

*CONTINUED*

## Audio System

---

### Disc Scan

When activated, Disc Scan plays about 10 seconds of the first track of each CD in the order they are stored in the CD changer. To activate Disc Scan, press and hold the SCAN button until you see D-SCAN in the display.

If you do nothing, the system will then play the next CD's first track. When it plays a disc that you want to continue listening to, press the SCAN button again.

### Track Repeat

When activated, Track Repeat plays the current track continuously. To activate Track Repeat, press and release the RPT button. You will see RPT in the display as a reminder. To turn off Track Repeat, press the RPT button again, or press either side of the SKIP bar.

### Disc Repeat

When activated, Disc Repeat plays the current CD continuously. To activate Disc Repeat, press and hold the RPT button until you see D-RPT in the display. To turn off Disc Repeat, press the RPT button again, or press either side of the SKIP bar.

To take the system out of CD mode, press the AM/FM button. Each time you press the AM/FM button, the system will change to the next mode; FM1, FM2, or AM. When you return to CD mode by pressing the CD button, play will continue at the same point that it left off.

If you turn the system off while a CD is playing, either with the PWR/VOL knob or the ignition switch, play will continue at the same point when you turn it back on.

## ***Removing CDs from the Changer***

To remove the disc that is currently playing, press the eject button. You will see “EJEC” in the display. When you remove the disc from the slot, the system automatically begins the Load sequence so you can load another CD in that position. If you do not load another CD, after 15 seconds, the system selects the previous mode (AM, FM1, or FM2).

If you do not remove the disc from the slot, the system will reload the disc after 15 seconds, and select the previous mode (AM or FM). To begin playing the disc, press the CD button.

To remove a different CD from the changer, first select it with the appropriate preset button. When that CD begins playing, press the eject button.

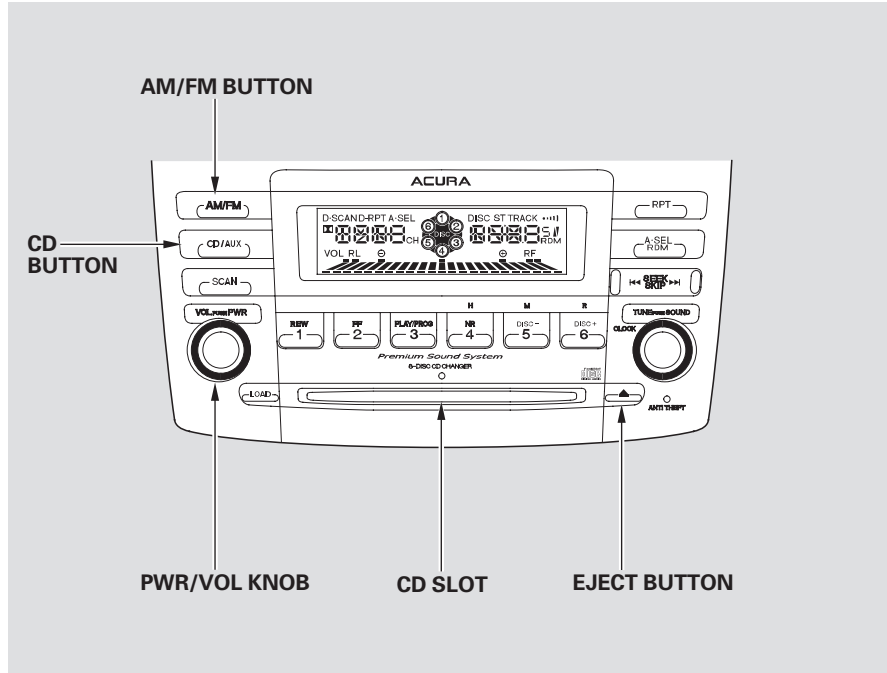

*CONTINUED*



## Audio System

---

If you press the eject button while listening to the radio, or with the audio system turned off, the disc that was last selected is ejected. After that disc is ejected, pressing the eject button again will eject the next disc in numerical order. By doing this six times, you can remove all the CDs from the changer.

In any mode, if you press the eject button and hold it until you hear a beep, the system will eject all of the discs in the changer.

You can also eject discs when the ignition switch is off. The disc that was last selected is ejected first. You can eject all six discs, one at a time.

### **Protecting Compact Discs**

For information on how to handle and protect compact discs, see page [165](#).

### CD Changer Error Indications

If you see an error indication in the display while operating the CD changer, find the cause in the chart to the right. If you cannot clear the error indication, take the car to your Acura dealer.

Indication	Cause	Solution
<i>CD DISC</i>	FOCUS Error	Press the CD eject button and pull out the CDs. Check for an error indication. Insert the CDs again. If the code does not disappear or the CDs cannot be pulled out, consult your Acura dealer.
<i>CD ERR</i>	Mechanical Error	Press the CD eject button and pull out the CDs. Check for an error indication. Insert the CDs again. If the code does not disappear or the CDs cannot be pulled out, consult your Acura dealer.
<i>CD EJECT</i>	No CD in the CD Changer	Insert CDs.

## Audio System

### Operating the Cassette Player (Optional)

The cassette system features Dolby\* noise reduction, automatic sensing of chromium-dioxide (CrO<sub>2</sub>) tape, and auto-reverse for continuous play.

To operate the cassette player, the ignition switch must be in the ACCESSORY (I) or ON (II) position. Make sure the tape opening on the cassette is facing to the right, then insert the cassette most of the way into the slot. The system will pull it in the rest of the way, and begin to play.

\* Dolby noise reduction manufactured under license from Dolby Laboratories Licensing Corporation. "DOLBY" and the double-D symbol  are trademarks of Dolby Laboratories Licensing Corporation.

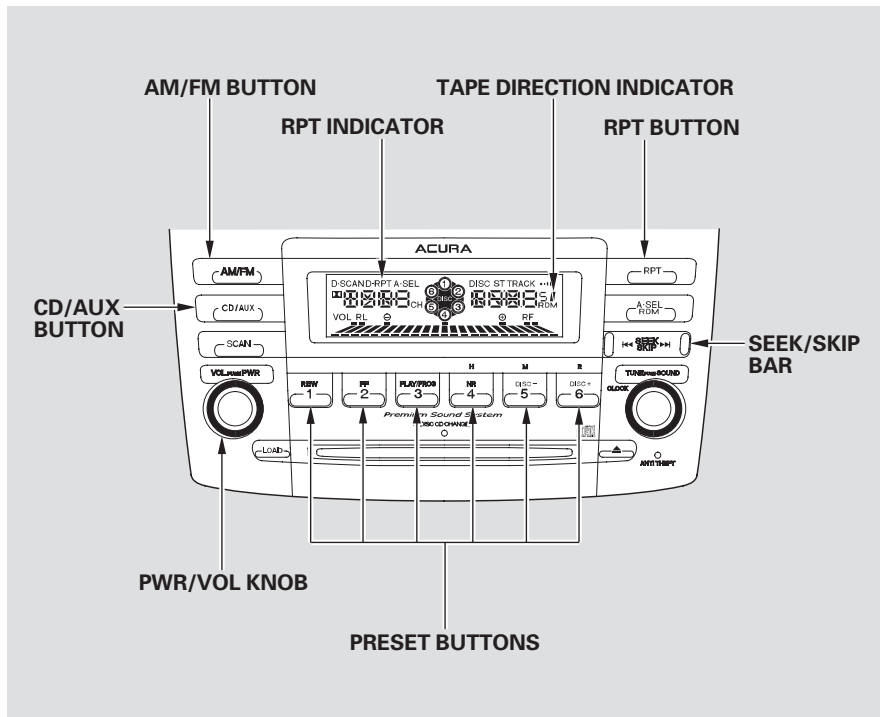

The tape direction indicator will light to show you which side of the cassette is playing. The ▲ indicates the side you inserted facing upward is now playing. If you want to play the other side, press the Preset 3 button.

Dolby noise reduction turns on when you insert a cassette. The □□ indicator will light in the display. If the tape was not recorded with Dolby noise reduction, turn it off by pressing the Preset 4 button.

Noise reduction remains off until you turn it on by pressing the button again.

When the system reaches the end of the tape, it will automatically reverse direction and play the other side. If you want to remove the cassette from the drive, press the eject button on the cassette player.

If you turn the system off while a tape is playing, either with the PWR/VOL knob or by turning off the ignition, the cassette will remain in the drive. When you turn the system back on, the cassette player will be in pause mode. To begin playing, press the Preset 3 (PLAY/PROG) button.

To switch to the radio or CD changer while a tape is playing, press the AM/FM or CD/AUX button. To change back to the cassette player, push the CD/AUX button.

## Audio System

---

### Tape Search Functions

With a cassette playing, you can use the FF, REW, SKIP, or REPEAT function to find a desired program.

**FF/REW** — Fast Forward and Rewind move the tape rapidly. To rewind the tape, push the Preset 1 (REW) button. You will see REW in the display. To fast forward the tape, push the Preset 2 (FF) button. You will see FF displayed. Press the Preset 1, 2, or 3 button to take the system out of rewind or fast forward. When the system reaches the end of the tape, it reverses direction and begins to play.

**SKIP** — The Skip function allows you to find the beginning of a song or passage. To activate SKIP, press the SEEK/SKIP bar. Press the **▶▶|** side to advance to the beginning of the next song or passage, or the **|◀◀** side to return to the beginning of the current song or passage. FF or REW will flash in the display as the tape moves. When the system reaches the beginning of the next song or passage (FF), or the beginning of the current one (REW), it goes back to PLAY mode.

**REPEAT** — The Repeat function continuously replays the current song or passage. Press the RPT button to activate it; you will see RPT displayed as a reminder. When the system reaches the end of the song or passage currently playing, it will automatically go into rewind. When it senses the beginning of the same song or passage, the system returns to PLAY mode. It will continue to repeat this same program until you deactivate REPEAT by pressing the button again.

The SKIP and REPEAT functions use silent periods on the tape to find the end of a song or passage. These features may not work to your satisfaction if there is almost no gap between selections, a high noise level between selections, or a silent period in the middle of a selection.

**Caring for the Cassette Player**  
Damaged cassettes can jam inside the drive or cause other problems. See page 170 for information on cassette care and protection.

# Audio System

## With Navigation System AM/FM/CD Changer Audio System

Your Acura's audio system provides clear reception on both AM and FM bands, while the preset icons in the audio display allow you to easily select your favorite stations.

The in-dash CD changer holds up to six discs. You operate the CD changer with the same controls used for the radio. See page 156 for CD changer operation.

The anti-theft feature will disable the system if it is disconnected from the car's battery. To get the system working again, you must enter a code number (see page 172).

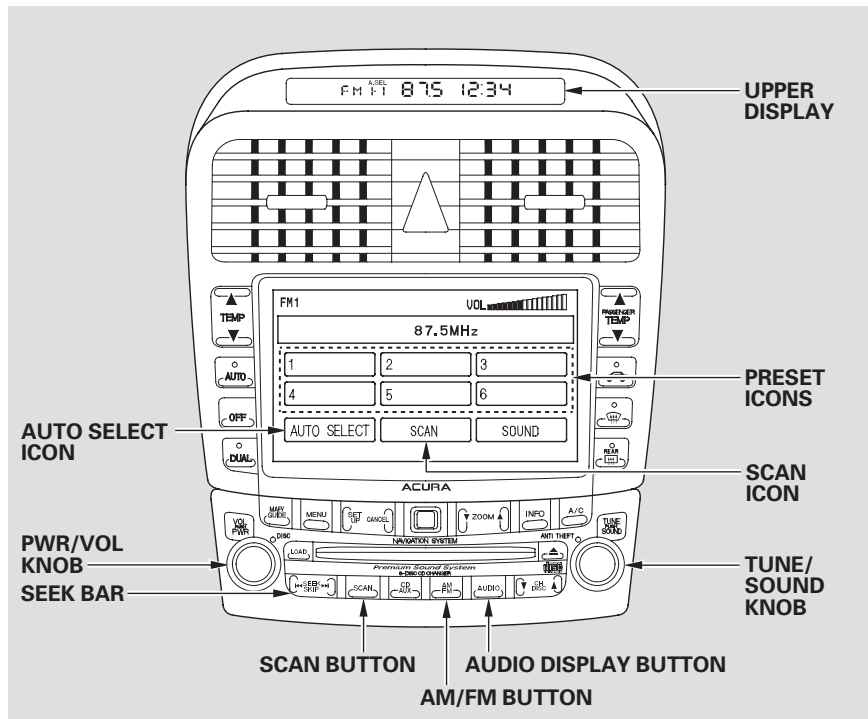

### Operating the Radio

The ignition switch must be in ACCESSORY (I) or ON (II) to operate the audio system. Turn the system on by pressing the PWR/VOL knob, the AM/FM button, or the AUDIO DISPLAY button. Adjust the volume by turning the knob.

The band and frequency that the radio was last tuned to is displayed. To change bands, press the AM/FM button. On the FM band, ST will be seen in the upper display if the station is broadcasting in stereo. Stereo reproduction on AM is not available.

You can use any of five methods to find radio stations on the selected band: TUNE, SEEK, SCAN, AUTO SELECT, and the preset icons.

**TUNE** — Use the TUNE knob to tune the radio to a desired frequency. Turn the knob to the right to tune to a higher frequency, or to the left to tune to a lower frequency.

**SEEK** — The SEEK function searches the band for a station with a strong signal. To activate it, press the SEEK bar ( ◀◀ or ▶▶ ), then release it. Depending on which side of the SEEK bar you press, the system scans upward or downward from the current frequency. It stops when it finds a station with a strong signal.

**SCAN** — The SCAN function samples all the stations with strong signals on the selected band. To activate it, push and release the SCAN button or touch the SCAN icon at the bottom of the display. You will see SCAN in the display. The system will scan up the band for a station with a strong signal. When it finds one, it will stop and play that station for about 5 seconds. If you do nothing, the system will then scan for the next strong station and play that for 5 seconds. When it plays a station that you want to continue listening to, press the SCAN button or touch the SCAN icon again.

*CONTINUED*



## Audio System

---

**Preset** — You can store the frequencies of your favorite radio stations in the six preset icons. Each icon will store one frequency on the AM band, and two frequencies on the FM band.

To store a frequency:

1. Push the AUDIO DISPLAY button to view the audio display. You will see the six preset icons.
2. Select the desired band, AM or FM. FM1 and FM2 let you store two frequencies with each preset icon.
3. Use the TUNE, SEEK, or SCAN function to tune the radio to a desired station.
4. Pick the preset icon (1–6) you want for that station. Touch the icon, and hold it until you hear two beeps.

5. Repeat steps 2 to 4 to store a total of six stations on AM and twelve on FM.

Once a station's frequency is stored, simply touch the proper preset icon to tune to it.

The preset frequencies will be lost if your car's battery goes dead, is disconnected, or the radio fuse is removed.

**AUTO SELECT** — If you are traveling far from home and can no longer receive the stations you preset, you can use the Auto Select feature to find stations in the local area.

To activate Auto Select, touch the Auto Select icon on the display. The A.SEL indicator will flash in the upper display, and the system will go into scan mode for several seconds. It automatically scans both bands, looking for stations with strong signals. It stores the frequencies of six AM stations and twelve FM stations in the preset icons. You can then use the preset icons to select those stations.

If you are in a remote area, Auto Select may not find six strong AM stations or twelve strong FM stations. If this happens, you will not see a station number on the corresponding preset icon.

If you do not like the stations Auto Select has stored, you can store other frequencies in the preset icons. Use the TUNE, SEEK, or SCAN function to find the desired frequencies, then store them in the selected preset icons as described previously.

Auto Select does not erase the frequencies that you preset previously. When you return home, turn off Auto Select by touching the AUTO SELECT icon. The preset icons will then select the frequencies you originally set.

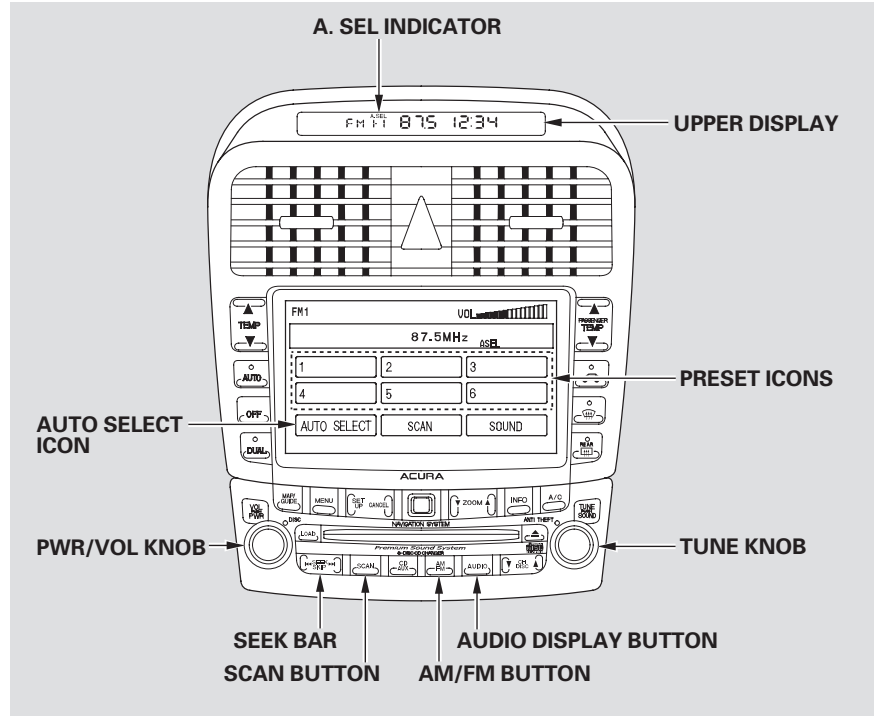

## Audio System

### Adjusting the Sound

Bass, Treble, Balance, and Fader are each adjustable. To adjust them, enter the sound grid by touching the SOUND icon on the display or pressing the TUNE/SOUND knob.

**Treble/Bass** – To adjust the bass and treble, touch the ◀ or ▶ icon on each side of the Treble or Bass adjustment bar. The adjustment bar next to the Treble or Bass icon shows you the current setting.

**Balance/Fader** – These two modes adjust the strength of the sound coming from each speaker. Left and Right icons adjust the side-to-side strength, while Front and Rear icons adjust the front-to-back strength.

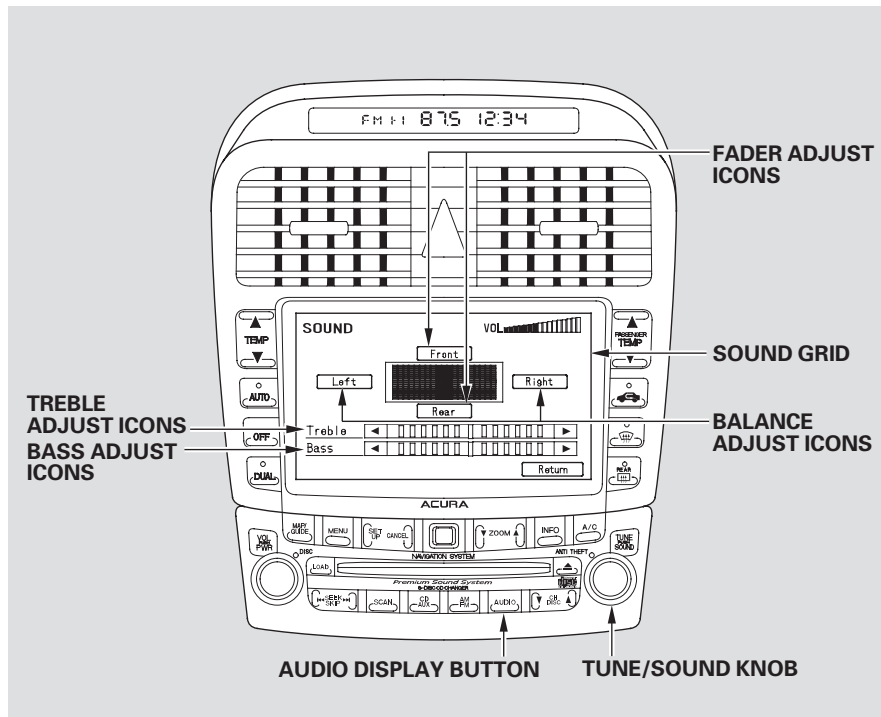

To adjust the balance, touch the left or right icon on the sound grid. When you touch an icon, the yellow bars on the grid turn orange and move toward the icon, changing the balance left or right. To equalize the balance, touch the left or right icon until each side has an orange bar at the center of the sound grid.

To adjust the fader, touch the front or rear icon on the sound grid. When you touch an icon, the white bars on the grid turn orange and move toward the icon, changing the fader to the front or rear. To equalize the fader, touch the front or rear icon until each side has an orange bar at the center of the sound grid.

To see the audio screen when you are finished adjusting the sound, touch the RETURN icon or wait five seconds.

If you want to adjust the sound while the radio/CD is playing, push the AUDIO DISPLAY button, then touch the SOUND icon in the display.

To return to the previous display, push the AUDIO DISPLAY button again.

### **Digital Clock**

The upper display shows the time when the ignition switch is in the ACCESSORY (I) or ON (II) position. The Navigation System receives signals from the Global Positioning System (GPS), and the displayed time is updated automatically by the GPS. Refer to the Navigation System Owner's Manual to set up the time.

## Audio System

---

### Radio Frequencies

Your Acura's radio can receive the complete AM and FM bands. Those bands cover these frequencies:

AM band:

530 to 1,710 kilohertz

FM band:

87.7 to 107.9 megahertz

Radio stations on the AM band are assigned frequencies at least ten kilohertz apart (530, 540, 550). Stations on the FM band are assigned frequencies at least 0.2 megahertz apart (87.9, 88.1, 88.3).

Stations must use these exact frequencies. It is fairly common for stations to round-off the frequency in their advertising, so your radio could display a frequency of 100.9 even though the announcer may identify the station as "FM101."

### Radio Reception

How well your Acura's radio receives stations is dependent on many factors, such as the distance from the station's transmitter, nearby large objects, and atmospheric conditions.

A radio station's signal gets weaker as you get farther away from its transmitter. If you are listening to an AM station, you will notice the sound volume becoming weaker, and the station drifting in and out. If you are listening to an FM station, you will see the stereo indicator flickering off and on as the signal weakens. Eventually, the stereo indicator will go off and the sound will fade completely as you get out of range of the station's signal.

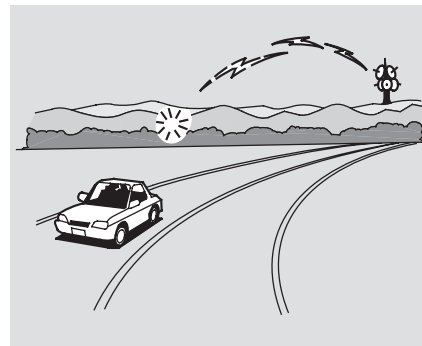

Driving very near the transmitter of a station that is broadcasting on a frequency close to the frequency of the station you are listening to can also affect your radio's reception. You may temporarily hear both stations, or hear only the station you are close to.

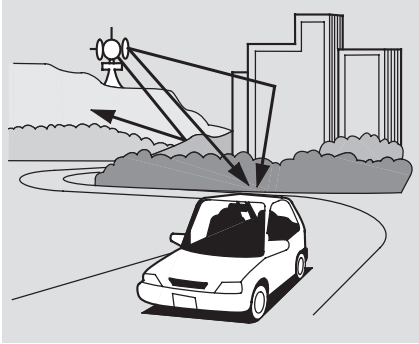

Radio signals, especially on the FM band, are deflected by large objects such as buildings and hills. Your radio then receives both the direct signal from the station's transmitter, and the deflected signal. This causes the sound to distort or flutter. This is a main cause of poor radio reception in city driving.



Radio reception can be affected by atmospheric conditions such as thunderstorms, high humidity, and even sunspots. You may be able to receive a distant radio station one day and not receive it the next day because of a change in conditions.

Electrical interference from passing vehicles and stationary sources can cause temporary reception problems.

*As required by the FCC:  
Changes or modifications not expressly approved by the party responsible for compliance could void the user's authority to operate the equipment.*

## Audio System

### Operating the CD Changer

Your Acura's audio system has an in-dash CD changer that holds up to six discs, providing several hours of continuous entertainment. You operate this CD changer with the same controls used for the radio.

To load CDs or operate the CD changer, the ignition switch must be in ACCESSORY (I) or ON (II).

Load and play only standard round discs. Odd-shaped CDs may jam in the drive or cause other problems. You cannot load and play 3-inch (8-cm) discs in this system.

For best results when using CD-R discs, use only high quality discs labeled for audio use. When recording a CD-R, the recording must be closed in order for the disc to be used by CD players. CD-RW discs will not work in this unit.

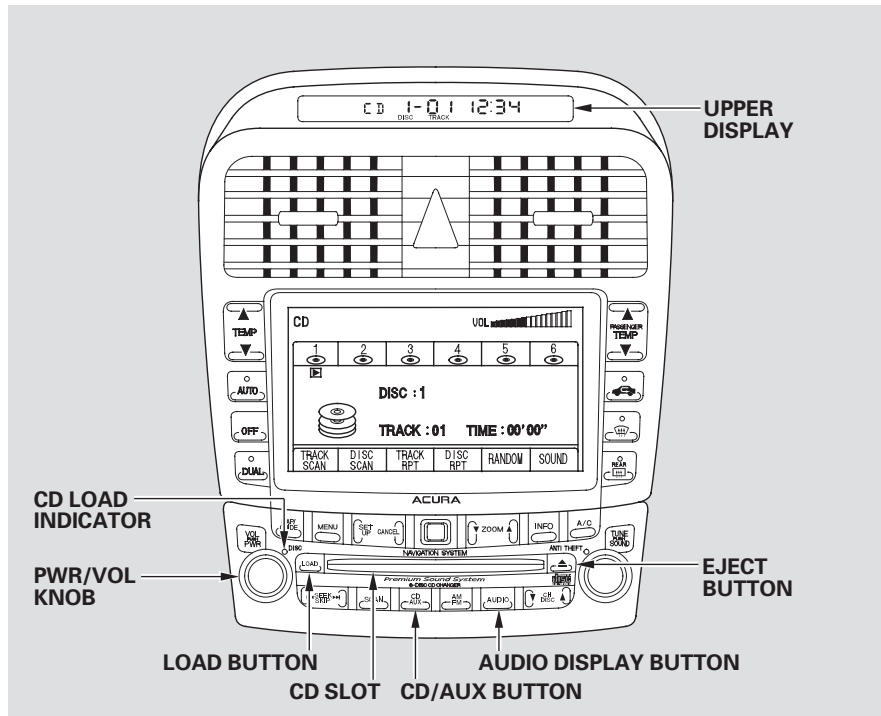

### ***Loading CDs in the Changer***

To load multiple CDs in one operation:

1. Press and hold the LOAD button until you hear a beep and see “LOAD” in the upper display, then release the button.
2. Insert the disc into the CD slot. Insert it only about halfway; the drive will pull it in the rest of the way. You will see “BUSY” in the display. The red CD load indicator blinks as the CD is loaded.
3. When “LOAD” appears again in the display, insert the next disc into the CD slot.

4. Repeat this until all six positions are loaded. The system will then begin playing the last CD loaded.

If you stop loading CDs before all six positions are filled, the system will wait for 10 seconds, stop the load operation, and begin playing the last CD loaded.

To load a single CD:

1. Press and release the LOAD button.
2. The disc number for an empty position is highlighted and the green CD load indicator comes on. When you see “LOAD” in the upper display, insert the disc into the CD slot. Insert it only about halfway; the drive will pull it in the rest of the way.
3. The system will load the CD, and begin playing it.

*CONTINUED*



## Audio System

If you press the LOAD button while a CD is playing, the system will stop playing that CD and start the loading sequence. It will then play the CD just loaded.

You can also load a CD into an empty position while a CD is playing by touching the appropriate disc icon. Select an empty position (the disc icon below the disc number is dark), and touch the icon for that position (1 – 6). The system will stop playing the current CD and start the loading sequence. It will then play the CD just loaded.

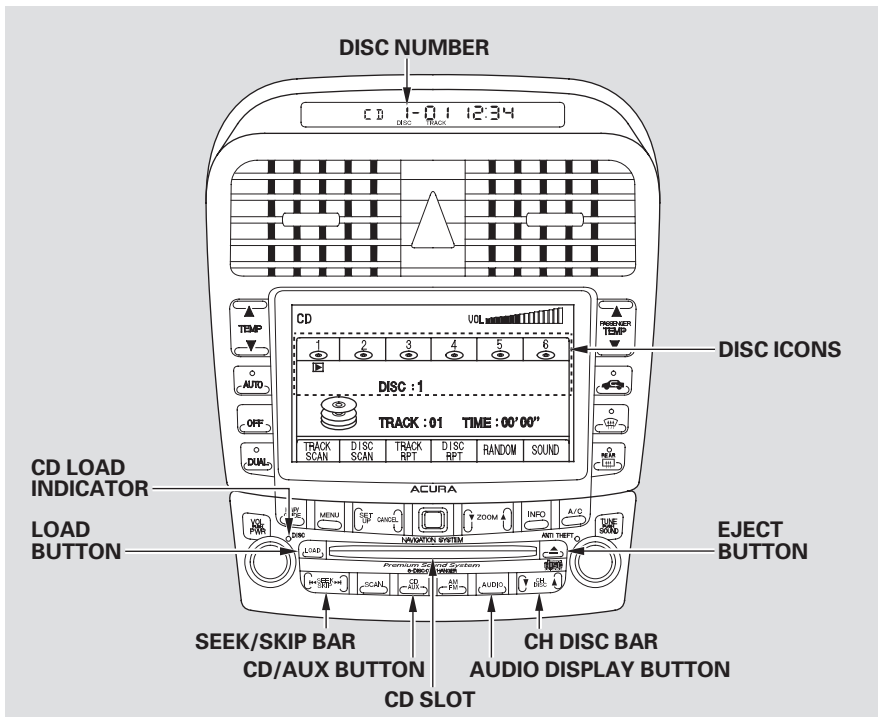

### **Operation**

Select the CD changer by pressing the CD/AUX button. You will see “CD” in the upper display. The system will begin playing the last selected disc in the CD changer. You will see the disc and track numbers displayed.

When that disc ends, the next disc in the CD changer is loaded and played. After the last disc finishes, the system returns to disc one.

To select a different disc, touch the appropriate disc icon (1 – 6) or press the “▲” or “▼” on the CH DISC bar. If you use a disc icon to select an empty position in the CD changer, the system will go into the loading sequence (see page 157).

You can use the SKIP bar while a disc is playing to select passages and change tracks.

To move rapidly within a track, press and hold “▲” or “▼” on the SKIP bar. The system will continue to move through the track. Press ▲ to move forward, or ▼ to move backward. Release the bar when the system reaches the point you want.

Each time you press and release ▲, the system skips forward to the beginning of the next track. Press and release ▼ to skip backward to the beginning of the current track. Press it again to skip to the beginning of the previous track.

### **Track Scan**

When you touch the TRACK SCAN icon on the audio display, the first track of the current CD plays for about 10 seconds. You will see TRACK SCAN highlighted in the display (or SCAN in the upper display). To hear the rest of the track, touch TRACK SCAN again, within 10 seconds. If you don't, the system advances to the next track, plays about 10 seconds of it, and continues through the rest of the tracks the same way.

## Audio System

---

### **Disc Scan**

When you touch the DISC SCAN icon on the audio display, the first track of the current CD plays for about 10 seconds. You will see DISC SCAN in the display (or D-SCAN in the upper display). To hear the rest of the CD, touch DISC SCAN again, within 10 seconds. If you don't, the system advances to the next CD, plays about 10 seconds of it, and continues through the rest of the CDs the same way. When the system reaches the last CD, DISC SCAN is cancelled, and the CD plays normally.

### **Track Repeat**

When you touch the TRACK RPT icon on the audio display, the system continuously replays the current track. As a reminder, you will see TRACK REPEAT in the display (or RPT in the upper display). To turn this feature off, touch TRACK REPEAT again.

### **Disc Repeat**

When you touch the DISC RPT icon on the audio display, the system continuously replays the current CD. As a reminder, you will see DISC REPEAT in the display (or D-RPT in the upper display). To turn this feature off, touch DISC RPT again.

### **Random Play**

When you touch the RANDOM icon on the audio display, the system plays the tracks of the current CD in random order, rather than in the order they were recorded. As a reminder, you will see TRACK RANDOM in the display. To turn this feature off, touch RANDOM again, or select a different CD with one of the disc icons.

To take the system out of CD mode, press the AM/FM button. Each time you press the AM/FM button, the system changes to the next mode (AM, FM1, or FM2). When you return to CD mode by pressing the CD button, play will continue at the same point that it left off.

If you turn the system off while a CD is playing, either with the PWR/VOL knob or the ignition switch, play will continue at the same point when you turn it back on.

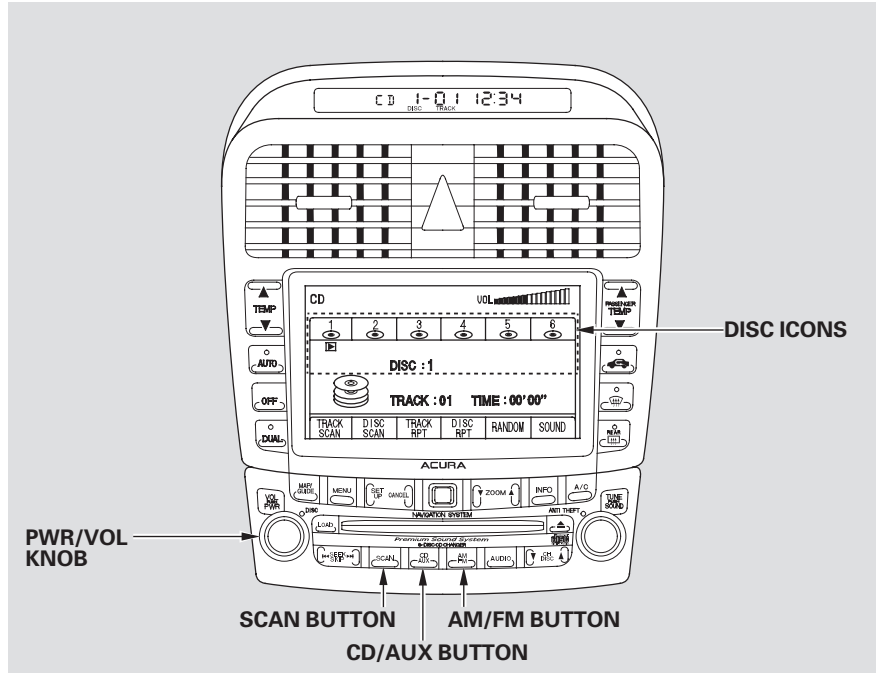

CONTINUED

## Audio System

### *Removing CDs from the Changer*

To remove the disc that is currently playing, press the eject button. You will see “EJEC” in the upper display. When you remove the disc from the slot, the system automatically begins the load sequence so you can load another CD in that position. If you do not load another CD, within 15 seconds, the system selects the previous mode (AM, FM1, or FM2).

If you do not remove the disc from the slot, the system will reload the disc after 15 seconds and put the CD changer in pause mode. To begin playing the disc, press the CD button.

To remove a different CD from the changer, first select it with the appropriate disc icon or the DISC bar. When that CD begins playing, press the eject button.

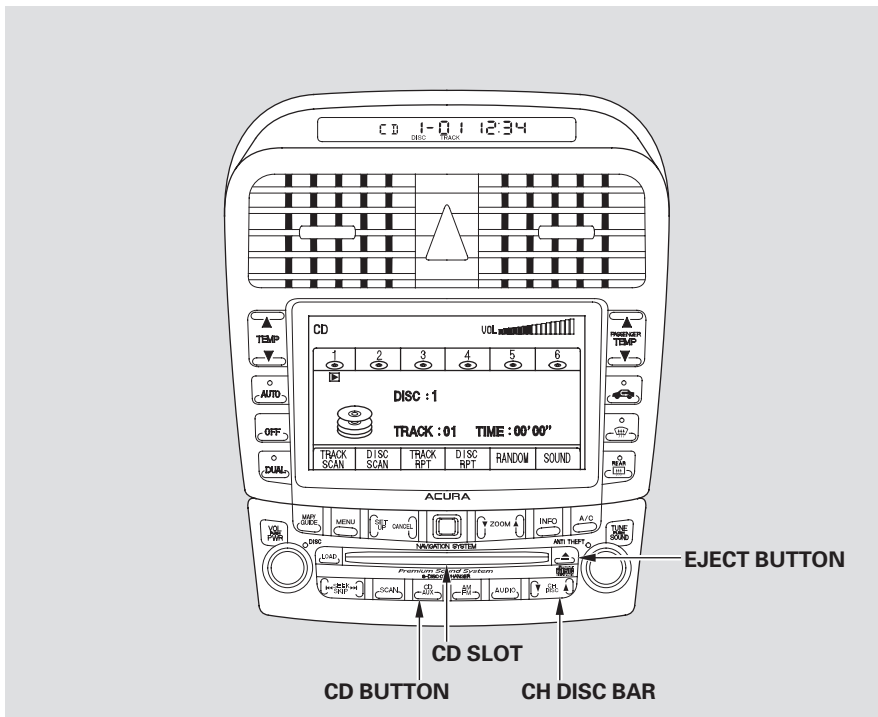

If you press the eject button while listening to the radio, or with the audio system turned off, the disc that was last selected is ejected. After that disc is ejected, pressing the eject button again will eject the next disc in numerical order. By doing this six times, you can remove all the CDs from the changer.

In any mode, if you press the eject button and hold it until you hear a beep, the system will eject all of the discs in the changer.

You can also eject discs when the ignition switch is off by pressing the eject button. The disc that was last selected is ejected first. You can eject all six discs, one at a time.

## Audio System

---

### CD Changer Error Indications

If you see an error indication in the upper display while operating the CD changer, find the cause in the chart to the right. If you cannot clear the error indication, take the car to your Acura dealer.

Indication	Cause	Solution
<i>CD DISC</i>	FOCUS Error	Press the CD eject button and pull out the CDs. Check for an error indication. Insert the CDs again. If the code does not disappear or the CDs cannot be pulled out, consult your Acura dealer.
<i>CD ERR</i>	Mechanical Error	Press the CD eject button and pull out the CDs. Check for an error indication. Insert the CDs again. If the code does not disappear or the CDs cannot be pulled out, consult your Acura dealer.

### Protecting Compact Discs

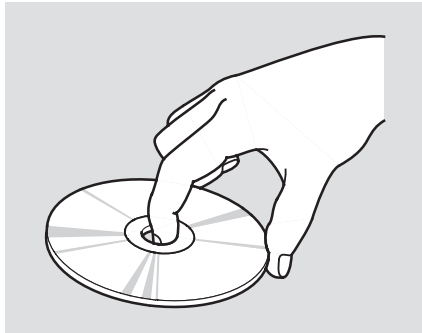

Handle a CD by its edges; never touch either surface. Do not place stabilizer rings or labels on the CD. These, along with contamination from fingerprints, liquids, and felt-tip pens, can cause the CD to not play properly, or possibly jam in the drive.

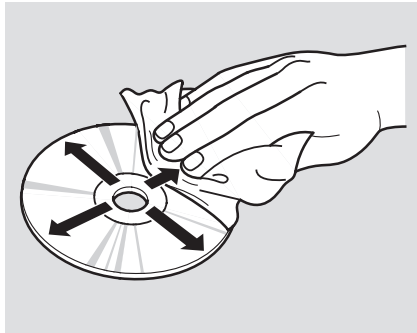

When a CD is not being played, store it in its case to protect it from dust and other contamination. To prevent warpage, keep CDs out of direct sunlight and extreme heat.

To clean a disc, use a clean soft cloth. Wipe across the disc from the center to the outside edge.

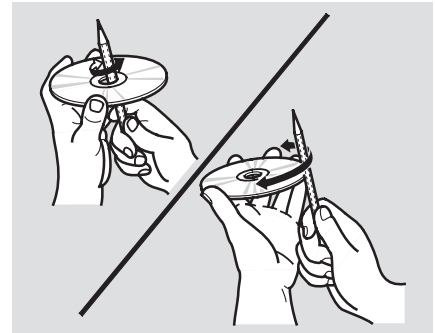

A new CD may be rough on the inner and outer edges. The small plastic pieces causing this roughness can flake off and fall on the recording surface of the disc, causing skipping or other problems. Remove these pieces by rubbing the inner and outer edges with the side of a pencil or pen.

Never try to insert foreign objects in the CD changer.



## Audio System

### Operating the Cassette Player (Optional)

The cassette system features Dolby\* noise reduction, automatic sensing of chromium-dioxide (CrO<sub>2</sub>) tape, and auto-reverse for continuous play.

To operate the cassette player, the ignition switch must be in ACCESSORY (I) or ON (II). Make sure the tape opening on the cassette is facing to the right, then insert the cassette most of the way into the slot. The system will pull it in the rest of the way, and begin to play.

\* Dolby noise reduction manufactured under license from Dolby Laboratories Licensing Corporation. "DOLBY" and the double-D symbol  are trademarks of Dolby Laboratories Licensing Corporation.

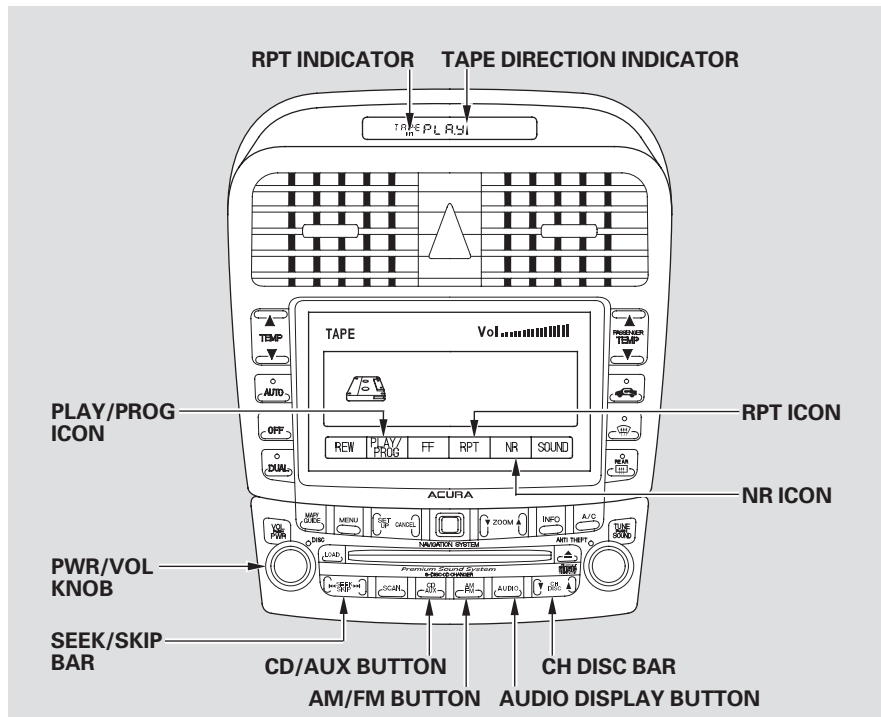

The tape direction indicator on the upper display will light to show you which side of the cassette is playing. The ▲ indicates the side you inserted facing upward is now playing. If you want to play the other side, push the AUDIO DISPLAY button to change to the audio display, then touch the PLAY/PROG icon.

Dolby noise reduction turns on when you insert a cassette. If the tape was not recorded with Dolby noise reduction, push the AUDIO DISPLAY button to change to the audio display, and turn it off by touching the NR icon.

Noise reduction remains off until you turn it on by pressing the icon again.

When the system reaches the end of the tape, it will automatically reverse direction and play the other side. If you want to remove the cassette from the drive, press the eject button on the cassette player.

If you turn the system off while a tape is playing, either with the PWR/VOL knob or by turning off the ignition, the cassette will remain in the drive. When you turn the system back on, the cassette player will be in pause mode. To begin playing, push the AUDIO DISPLAY button to change to the audio display, then touch the PLAY/PROG icon.

To switch to the radio or CD changer while a tape is playing, press the AM/FM or CD/AUX button. To change back to the cassette player, push the CD/AUX button.

## Audio System

---

### Tape Search Functions

With a cassette playing, you can use the FF, REW, SKIP, or REPEAT function to find a desired song or passage.

**FF/REW** — Fast Forward and Rewind move the tape rapidly. To rewind the tape, push “▲” on the CH DISC bar. You will see REW in the display. To fast forward the tape, push “▼” on the CH DISC bar. You will see FF displayed. To take the system out of rewind or fast forward, press “▲” or “▼” on the CH DISC bar or touch the PLAY/PROG icon on the audio display. When the system reaches the end of the tape, it reverses direction and begins to play.

**SKIP** — The Skip function allows you to find the beginning of a song or passage. To activate Skip, press the SEEK/SKIP bar. Press “▲” to advance to the beginning of the next song or passage, or “▼” to return to the beginning of the current song or passage. FF or REW will be shown in the upper display as the tape moves. When the system reaches the beginning of the next song or passage (FF), or the beginning of the current one (REW), it goes back to Play mode.

**REPEAT** – The Repeat function continuously replays the current song or passage. Press the AUDIO DISPLAY button to change to the audio display, then touch the RPT icon; you will see RPT in the upper display as a reminder. When the system reaches the end of the song or passage currently playing, it will automatically go into rewind. When it senses the beginning of the same song or passage, the system returns to Play mode. It will continue to repeat this same program until you deactivate Repeat by touching the RPT icon again.

The Skip and Repeat functions use silent periods on the tape to find the end of a song or passage. These features may not work to your satisfaction if there is almost no gap between selections, a high noise level between selections, or a silent period in the middle of a selection.

## Audio System

---

### **Caring for the Cassette Player**

The cassette player picks up dirt and oxides from tapes. This contamination builds up over time and causes the sound quality to degrade. To prevent this, you should clean the player after every 30 hours of use. Your dealer has a cleaning kit available.

If you do not clean the cassette player regularly, it may eventually become impossible to remove the contamination with a normal cleaning kit.

Use 100-minute or shorter cassettes. Cassettes longer than that use thinner tape that may break or jam the drive.

Look at the cassette before you insert it. If the tape is loose, tighten it by turning a hub with a pencil or your finger.

If the label is peeling off, remove it from the cassette or it could cause the cassette to jam in the player. Never try to insert a warped or damaged cassette in the player.

When they are not in use, store cassettes in their cases to protect them from dust and moisture. Never place cassettes where they will be exposed to direct sunlight, high heat, or high humidity. If a cassette is exposed to extreme heat or cold, let it reach a moderate temperature before inserting it in the player.

Never try to insert foreign objects into the cassette player.

### *On Audio Systems without Navigation System*

If you see the error indication “*TAPE ERR*” flashing on the display, press the TAPE eject button to remove the cassette from the unit. Make sure the tape is not damaged. If the cassette will not eject or the error indication stays on after the cassette ejects, take the car to your Acura dealer.

### *On Audio Systems with Navigation System*

If you see the error indication “*TAPE ERR*” on the upper display, press the TAPE eject button to remove the cassette from the unit. Make sure the tape is not damaged. If the cassette will not eject or the error indication stays on after the cassette ejects, take the car to your Acura dealer.

### Remote Audio Controls

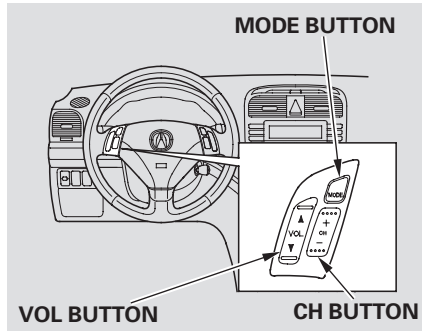

Three controls for the audio system are mounted in the steering wheel hub. They let you control basic functions without removing your hands from the wheel.

The VOL button adjusts the volume up (▲) or down (▼). Press the top or bottom of the button and hold it until the desired volume is reached, then release it.

The MODE button changes the mode. Pressing the button repeatedly selects FM1, FM2, AM, CD (if a CD is loaded), or a cassette (if equipped).

If you are listening to the radio, use the CH button to change stations. Each time you press the top (+) of the button, the system goes to the next preset station on the band you are listening to. Press the bottom (–) to go back to the previous station.

If you are playing a CD, the system skips to the beginning of the next track each time you press the top (+) of the CH button. Press the bottom (–) to return to the beginning of the current track. Press it again to return to the previous track. You will see the disc and track number in the display.

If you are playing a tape in the optional cassette player, press the top (+) of the CH button to advance to the next selection. Press the bottom (–) to go back to the previous selection. The system senses a silent period, then goes back to Play mode.

## Audio System

---

### Theft Protection

Your car's audio system will disable itself if it is disconnected from electrical power for any reason. To make it work again, the user must enter a specific code using the preset buttons or the TUNE knob. Because there are hundreds of number combinations possible, making the system work without knowing the exact code is nearly impossible.

You should have received a card that lists your audio system's code number and serial number. It is best to store this card in a safe place at home. In addition, you should write the audio system's serial number in this Owner's Manual. If you should happen to lose the card, you must obtain the code number from your Acura dealer. To do this, you will need the system's serial number.

If your car's battery is disconnected or goes dead, or the radio fuse is removed, the audio system will disable itself. If this happens, you will see "CODE"/"CODE" in the frequency display the next time you turn on the system. Use the preset buttons or the TUNE knob to enter the code.

If your car is equipped with a navigation system, press and release the TUNE knob; the number "0" appears on the display.

- If "0" is the first digit in your code, press and release the TUNE knob to store it.
- If "0" is not the first digit in your code, turn the TUNE knob left or right until the first digit is displayed. Press and release the TUNE knob to store it. Enter the remaining digits the same way.

When all the digits in the code are entered correctly, the radio will start playing.

If you make a mistake entering the code, do not start over or try to correct your mistake. Complete the sequence, then enter the correct code. You have ten tries to enter the correct code. If you are unsuccessful in ten attempts, you must then leave the system on for 1 hour before trying again.

You will have to store your favorite stations in the preset buttons after the system begins working. Your original settings were lost when power was disconnected.

The security system helps to protect your car and valuables from theft. The horn sounds and a combination of headlights, parking lights, side marker lights, and taillights flash if someone attempts to break into your car or remove the radio. This alarm continues for 2 minutes, then the system resets. To reset an alarming system before the 2 minutes have elapsed, unlock either front door with the key or the remote transmitter.

The security system automatically sets 15 seconds after you lock the doors, hood, and trunk. For the system to activate, you must lock the doors from the outside with the key, lock tab, door lock switch, or remote transmitter. The security system indicator on the instrument panel starts blinking immediately to show you the system is setting itself.

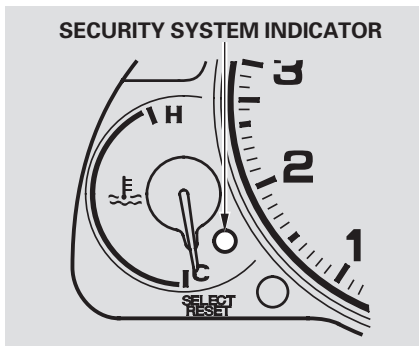

Once the security system is set, opening any door (without using the key or the remote transmitter), the hood, or the trunk will cause it to sound. It also sounds if the radio is removed from the dashboard or the wiring is cut.

With the system set, you can still open the trunk with the remote transmitter without triggering the alarm. The alarm will sound if the trunk lock is forced, or the trunk is opened with the trunk release handle or the emergency trunk opener.

The security system will not set if the hood, trunk, or any door is not fully closed. If the system will not set, check the Door and Trunk Open Monitor on the instrument panel (see page 62), to see if the doors and trunk are fully closed. Since it is not part of the monitor display, manually check the hood.

Do not attempt to alter this system or add other devices to it.



## Cruise Control

Cruise control allows you to maintain a set speed above 25 mph (40 km/h) without keeping your foot on the accelerator pedal. It should be used for cruising on straight, open highways. It is not recommended for conditions such as city driving, winding roads, slippery roads, heavy rain, or bad weather. You should have full control of the car under those conditions.

### **⚠ WARNING**

Improper use of the cruise control can lead to a crash.

Use the cruise control only when traveling on open highways in good weather.

### Using the Cruise Control

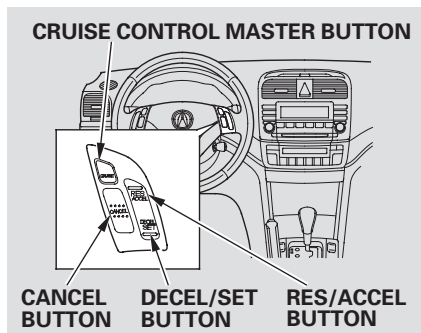

1. Push in the Cruise Control Master Button on the steering wheel. The CRUISE MAIN light on the instrument panel comes on.
2. Accelerate to the desired cruising speed above 25 mph (40 km/h).

3. Press and release the DECEL/SET button on the steering wheel. The CRUISE CONTROL light on the instrument panel comes on to show the system is now activated.

The cruise control may not hold the set speed when you are going up and down hills. If your speed increases going down a hill, use the brakes to slow down to the desired speed. This will cancel the cruise control. To resume the set speed, press the RES/ACCEL button. The CRUISE CONTROL light on the instrument panel comes on.

When climbing a steep hill, the automatic transmission may downshift to hold the set speed.

### Changing the Set Speed

You can increase the set cruising speed in any of these ways:

- Press and hold the RES/ACCEL button. The car will accelerate. When you reach the desired cruising speed, release the button.
- Push on the accelerator pedal. Accelerate to the desired cruising speed and press the DECEL/SET button.
- To increase your speed in very small amounts, tap the RES/ACCEL button repeatedly. Each time you do this, your car will speed up about 1 mph (1.6 km/h).

You can decrease the set cruising speed in any of these ways:

- Press and hold the DECEL/SET button. The car will decelerate. Release the button when you reach the desired speed.
- To slow down in very small amounts, tap the DECEL/SET button repeatedly. Each time you do this, your car will slow down about 1 mph (1.6 km/h).
- Tap the brake or clutch pedal lightly with your foot. The CRUISE CONTROL light on the instrument panel will go out. When the car slows to the desired speed, press the DECEL/SET button. The car will then maintain the desired speed.

Even with the cruise control turned on, you can still use the accelerator pedal to speed up for passing. After completing the pass, take your foot off the accelerator pedal. The car will return to the set cruising speed.

Resting your foot on the brake or clutch pedal will cause the cruise control to cancel.

## Cruise Control

---

### Cancelling the Cruise Control

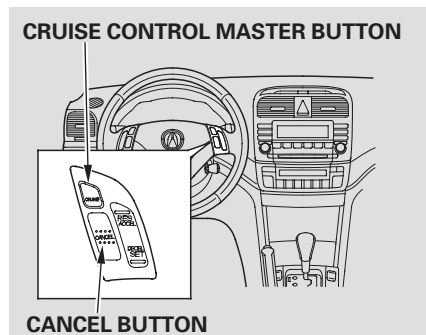

You can cancel the cruise control in any of these ways:

- Tap the brake or clutch pedal.
- Push the CANCEL button on the steering wheel.
- Press the Cruise Control Master button on the steering wheel.

When you push the CANCEL button, or tap the brake or clutch pedal, the CRUISE CONTROL light on the instrument panel will go out and the car will begin to slow down. You can use the accelerator pedal in the normal way.

The system remembers the previously-set cruising speed. To return to that speed, accelerate to above 25 mph (40 km/h), then press and release the RES/ACCEL button. The CRUISE CONTROL light comes on, and the car will accelerate to the same cruising speed as before.

Pressing the Cruise Control Master button turns the system completely off and erases the previous cruising speed from memory. To use the system again, refer to *Using the Cruise Control*.

The HomeLink® Wireless Control System built into your car can be programmed to operate remotely-controlled devices around your home, such as garage doors, lighting, or home security systems. It can replace up to three remote transmitters.

HomeLink® is a registered trademark of Johnson Controls™.

### **Customer Assistance**

If you have problems with training the HomeLink Wireless Control System, or would like information on home products that can be operated by the transmitter, call (800) 355-3515. On the Internet, go to [www.homelink.com](http://www.homelink.com).

### **Important Safety Precautions**

Always refer to the operating instructions and safety information that came with your garage door opener or other equipment you intend to operate with HomeLink. If you do not have this information, you should contact the manufacturer of the equipment.

While training or using HomeLink, make sure you have a clear view of the garage door or gate, and that no one will be injured by its movement.

### **General Information**

If you are training HomeLink to operate a garage door or gate, it is recommended that you unplug the motor for that device during training. Repeatedly pressing the remote control button could burn out the motor.

HomeLink stores the code in a permanent memory. There should be no need to retrain HomeLink if your car's battery goes dead or is disconnected.

If your garage door opener was manufactured before April 1982, you may not be able to program HomeLink to operate it. Garage door openers manufactured before that date do not have a safety feature that causes them to stop and reverse if an obstacle is detected during closing, increasing the risk of injury. If you have questions, call (800) 355-3515.

For quick and accurate training, make sure the remote control transmitter for the device (garage door, automatic gate, security system, etc.) has a fresh battery.

## HomeLink Wireless Control System

---

### Training HomeLink

Before you can use HomeLink to operate devices around your home, it must “learn” the proper codes. For example, to train HomeLink to open and close the garage door:

**Before you begin** — If you just took delivery of your car and have not trained any of the buttons in HomeLink before, you should erase any previously learned codes before training the first button. To do this, press and hold the two outside buttons on HomeLink for about 20 seconds, until the red light flashes. Release the buttons, then proceed to Step 1.

If you are training the second or third buttons, go directly to Step 1.

1. Unplug the garage door opener motor from the house current.
2. Hold the end of the garage door opener remote control 2 to 5 inches from HomeLink. Make sure you are not blocking your view of the red light in HomeLink.

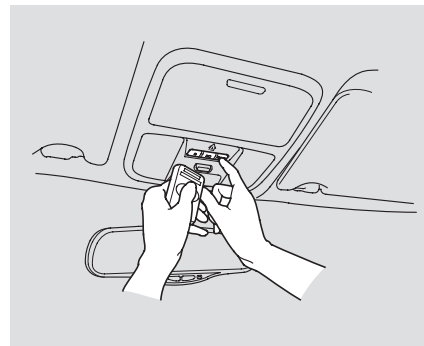

3. Select the HomeLink button you want to train.
4. Press the button on the remote control and the button on HomeLink at the same time. Hold down both buttons.

### *Canadian Owners:*

The remote control you are training may stop transmitting after two seconds. This is not long enough for HomeLink to learn the code. Release and press the button on the remote control every two seconds until HomeLink has learned the code.

5. The red light in HomeLink should begin flashing. It will flash slowly at first, then rapidly.
6. When the red light flashes rapidly, release both buttons. HomeLink should have learned the code from the remote control.
7. Plug in the garage door opener motor, then test the HomeLink button by pushing it. It should operate the garage door.

If the button does not work, repeat this procedure to train it again. If it still does not work, you may have a variable or rolling code garage door opener. Test this by pressing and holding the HomeLink button you just trained. If the red light blinks for two seconds, then stays on, you have a rolling code garage door opener. You may be able to verify this with the manufacturer's documentation. Go to "Training With a Rolling Code System."

8. Repeat these steps to train the other two HomeLink buttons to operate any other remotely-controlled devices around your home (lighting, automatic gate, security system, etc.).

### **Training With a Rolling Code System**

For security purposes, newer garage door opening systems use a "rolling" or variable code. Information from the remote control and the garage door opener are needed before HomeLink can operate the garage door opener.

The "Training HomeLink" procedure trains HomeLink to the proper garage door opener code. The following procedure synchronizes HomeLink to the garage door opener so they send and receive the correct codes.

*CONTINUED*

## HomeLink Wireless Control System

---

It may be helpful to have someone assist you with this procedure.

1. Make sure you have properly completed the “Training HomeLink” procedure.
2. Find the “Training” button on your garage door opener unit. The location will vary, depending on the manufacturer. The manufacturer’s documentation may help.

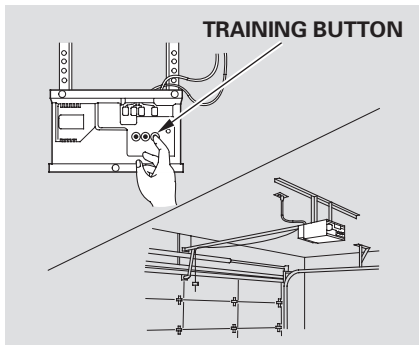

3. Press the Training button on the garage door opener unit until the light next to the button comes on, then release it. The light may blink, or come on and stay on. You then have approximately 30 seconds to complete the following steps.

4. Press and hold the button on HomeLink for 3 – 4 seconds. (The same button you trained with the “Training HomeLink” procedure.)
5. Press and hold the HomeLink button again for 3 – 4 seconds. This should turn off the training light on the garage door opener unit. (Some systems may require you to press the button up to three times.)
6. Press the HomeLink button again. It should operate the garage door.

## Retraining a Button

To train an already programmed HomeLink button to operate a new device:

1. Select the HomeLink button you want to train.
2. Press and hold the HomeLink button until the red light begins to flash slowly (approximately 20 seconds).
3. While continuing to hold the HomeLink button, place the remote control for the device 2 to 5 inches from HomeLink.
4. Press and hold the button on the remote control. Hold both buttons until the red light begins to flash rapidly.

5. Release both buttons. HomeLink should now be trained to operate the device.

## Erasing Codes

To erase the codes stored in all three HomeLink buttons, press and hold the two outside buttons until the red light begins to flash, then release the buttons.

You should erase all three codes before selling the car.

*As required by the FCC:*

*This device complies with Part 15 of the FCC rules. Operation is subject to the following two conditions: (1) This device may not cause harmful interference, and (2) this device must accept any interference received, including interference that may cause undesired operation.*

*Changes or modifications not expressly approved by the party responsible for compliance could void the user's authority to operate the equipment.*

*This device complies with Industry Canada Standard RSS-210.*

*Operation is subject to the following two conditions: (1) this device may not cause interference, and (2) this device must accept any interference that may cause undesired operation of the device.*





Before you begin driving your Acura, you should know what gasoline to use, and how to check the levels of important fluids. You also need to know how to properly store luggage or packages. The information in this section will help you. If you plan to add any accessories to your car, please read the information in this section first.

Break-in Period .....	184
Gasoline .....	184
Service Station Procedures .....	184
Filling the Fuel Tank.....	184
Opening the Hood .....	186
Oil Check .....	187
Engine Coolant Check .....	189
Fuel Economy .....	190
Car Condition .....	190
Driving Habits.....	190
Accessories and Modifications ....	191
Carrying Cargo .....	193

## Break-in Period, Gasoline, Service Station Procedures

---

### Break-in Period

Help assure your car's future reliability and performance by paying extra attention to how you drive during the first 600 miles (1,000 km). During this period:

- Avoid full-throttle starts and rapid acceleration.
- Avoid hard braking. New brakes need to be broken-in by moderate use for the first 200 miles (300 km).
- Do not change the oil until the recommended time or mileage interval shown in the maintenance schedule.

You should follow these same recommendations with an overhauled or exchanged engine, or when the brakes are relined.

### Gasoline

Your Acura is designed to operate on premium unleaded gasoline with a pump octane number of 91 or higher. Use of a lower octane gasoline can cause a persistent, heavy metallic rapping noise in the engine that can lead to mechanical damage.

We recommend gasolines containing detergent additives that help prevent fuel system and engine deposits. Using gasoline containing lead will damage your car's emissions controls. This contributes to air pollution.

In Canada, some gasolines contain an octane-enhancing additive called MMT. If you use such gasolines, your emissions control system performance may deteriorate and the Malfunction Indicator Lamp on your instrument panel may turn on. If this happens, contact your authorized Acura dealer for service.

### Filling the Fuel Tank

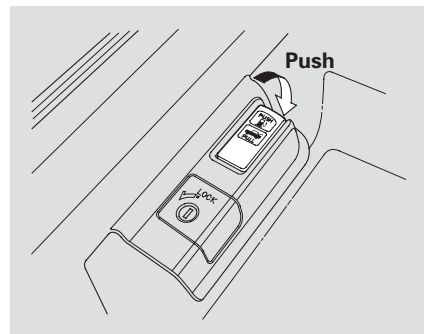

1. Because the fuel fill cap is on the driver's side of the car, park with that side closest to the service station pumps.
2. Open the fuel fill door by pushing on the handle to the left of the driver's seat.

### **⚠ WARNING**

Gasoline is highly flammable and explosive. You can be burned or seriously injured when handling fuel.

- Stop the engine and keep heat, sparks, and flame away.
- Handle fuel only outdoors.
- Wipe up spills immediately.

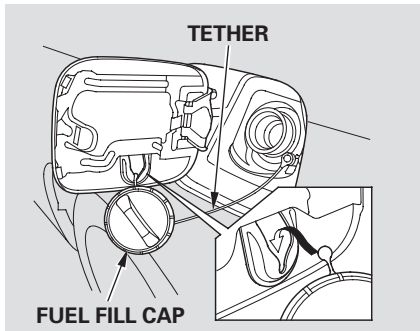

3. Remove the fuel fill cap slowly. You may hear a hissing sound as pressure inside the tank escapes. The fuel fill cap is attached to the fuel filler with a tether. Put the attachment on the fuel fill cap into the slit on the fuel fill door.
4. Stop filling the tank after the fuel nozzle automatically clicks off. Do not try to “top off” the tank, leave some room for the fuel to expand with temperature changes.
5. Screw the fuel fill cap back on, tighten it until it clicks at least three times. If you do not properly tighten the cap, the Malfunction Indicator Lamp may come on (see page 319).
6. Push the fuel fill door closed until it latches.

Your car has an on-board refueling vapor recovery system to help keep fuel vapors from going into the atmosphere. If the fuel nozzle keeps clicking off even though the tank is not full, there may be a problem with this system. Consult your dealer.

## Service Station Procedures

---

### Opening the Hood



1. Shift to Park or Neutral and set the parking brake. Pull the hood release handle located under the lower left corner of the dashboard. The hood will pop up slightly.

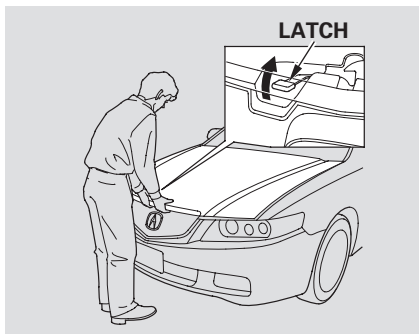

2. Standing in front of the car, put your fingers under the front edge of the hood to the right of center. Slide your hand to the left until you feel the hood latch handle. Push this handle up until it releases the hood. Lift the hood.

If you can open the hood without lifting the hood latch handle, or the hood latch handle moves stiffly or does not spring back as before, the mechanism should be cleaned and lubricated (see page [262](#)).

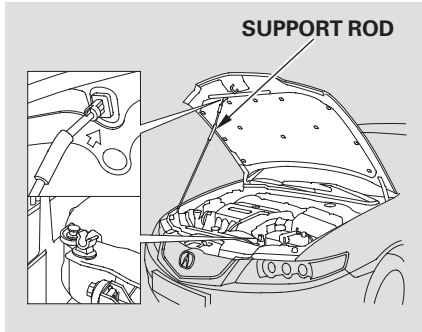

3. Pull the support rod out of its clip and insert the end into the hole on the front of the hood near the center.

To close the hood, lift it up slightly to remove the support rod from the hole. Put the support rod back into its holding clip. Lower the hood to about a foot (30 cm) above the fender, then let it drop. After closing the hood, make sure it is securely latched.

### *Oil Check*

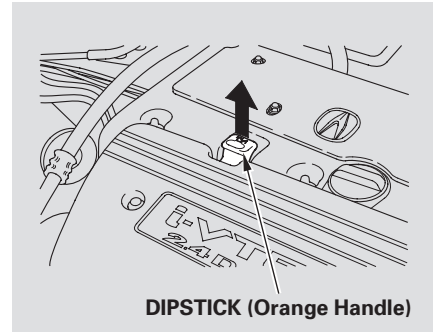

Check the engine oil level every time you fill the fuel tank. Wait a few minutes after turning the engine off before you check the oil.

1. Remove the dipstick.

*CONTINUED*

## Service Station Procedures

---



2. Wipe the dipstick with a clean cloth or paper towel.

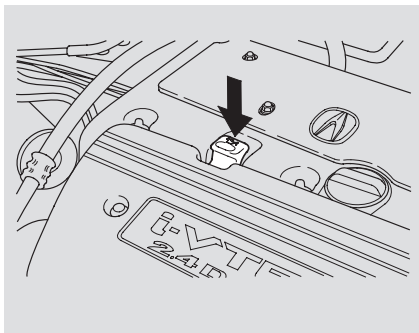

3. Insert it all the way back in its tube.

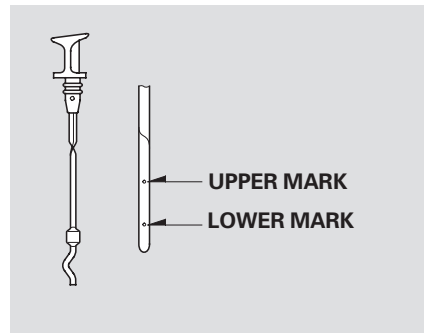

4. Remove the dipstick again and check the level. It should be between the upper and lower marks.

If it is near or below the lower mark, see **Adding Oil** on page [244](#).

### Engine Coolant Check

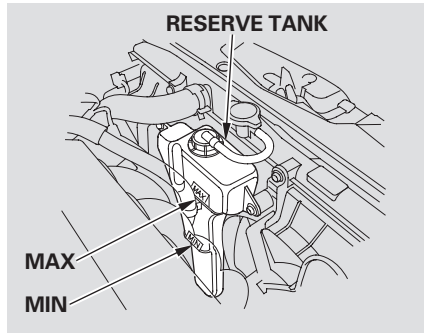

Look at the coolant level in the radiator reserve tank. Make sure it is between the MAX and MIN lines. If it is below the MIN line, see **Adding Engine Coolant** on page 249 for information on adding the proper coolant.

Refer to **Owner Maintenance Checks** on page 242 for information on checking other items in your Acura.



## Fuel Economy

---

The condition of your car and your driving habits are the two most important things that affect the fuel mileage you get.

### Car Condition

Always maintain your car according to the maintenance schedule. This will keep it in top operating condition.

An important part of that maintenance is the **Owner Maintenance Checks** (see page 242). For example, an underinflated tire causes more “rolling resistance,” which uses fuel. It also wears out faster, so check the tire pressure at least monthly.

In winter, the build-up of snow on your car’s underside adds weight and rolling resistance. Frequent cleaning helps your fuel mileage and reduces the chance of corrosion.

### Driving Habits

You can improve fuel economy by driving moderately. Rapid acceleration, abrupt cornering, and hard braking use more fuel.

Always drive in the highest gear that allows the engine to run and accelerate smoothly.

Depending on traffic conditions, try to maintain a constant speed. Every time you slow down and speed up, your car uses extra fuel. Use the cruise control, when appropriate, to increase fuel economy.

A cold engine uses more fuel than a warm engine. It is not necessary to “warm-up” a cold engine by letting it idle for a long time. You can drive away in about a minute, no matter how cold it is outside. The engine will warm up faster, and you get better fuel economy. To cut down on the number of “cold starts,” try to combine several short trips into one.

The air conditioning puts an extra load on the engine which makes it use more fuel. Turn off the A/C to cut down on air conditioning use. Use the flow-through ventilation when the outside air temperature is moderate.

Modifying your car, or installing some non-Acura accessories, can make your car unsafe. Before you make any modifications or add any accessories, be sure to read the following information.

### Accessories

Your Acura dealer has many Acura Accessories that allow you to personalize your car. These have all been approved for installation and use on your car, and are covered by warranty.

Non-Acura accessories are usually designed for universal applications. Although aftermarket accessories may fit on your car, they may not meet factory specifications, and could adversely affect your car's handling and stability. (See "Modifications" on page 192 for additional information.)

### **WARNING**

Improper accessories or modifications can affect your car's handling, stability, and performance, and cause a crash in which you can be hurt or killed.

Follow all instructions in this owner's manual regarding accessories and modifications.

When properly installed, cellular phones, alarms, two-way radios, and low-powered audio systems should not interfere with your car's computer-controlled systems, such as the SRS and anti-lock brake system.

However, if electronic accessories are improperly installed, or exceed your car's electrical system capacity, they can interfere with the operation

of your car, or even cause the airbags to deploy.

Before installing any accessory:

- Make sure the accessory does not obscure any lights, or interfere with proper car operation or performance.
- Be sure electronic accessories do not overload electrical circuits (see page 324).
- Have the installer contact your Acura dealer for assistance before installing any electronic accessory.

If possible, have your dealer inspect the final installation.

## Accessories and Modifications

---

### Modifications

Removing parts from your vehicle, or replacing components with non-Acura (aftermarket) components could seriously affect your vehicle's handling, stability, and reliability.

Some examples are:

- Lowering the vehicle with an aftermarket suspension kit that significantly reduces ground clearance can allow the undercarriage to impact speed bumps or other raised objects, which could cause the airbags to deploy.
- Raising the vehicle with an aftermarket suspension kit can affect the handling and stability.
- Aftermarket wheels, because they are a universal design, can cause excessive stress on suspension components.

- Larger or smaller wheels and tires can interfere with the operation of your vehicle's anti-lock brakes and other systems.

Do not modify your steering wheel or any other part of your Supplemental Restraint System. Modifications could make the system ineffective.

If you plan to modify your vehicle, consult with your Acura dealer.

### Additional Safety Precautions

- ***Do not attach or place objects on the front airbag covers.*** Any object attached to or placed on the covers marked "SRS AIRBAG," in the center of the steering wheel and on top of the dashboard, could interfere with the proper operation of the airbags. Or, if the airbags inflate, the objects could be propelled inside the car and hurt someone.

*On models equipped with side airbags or side curtain airbags*

- ***Do not attach hard objects on or near a front door.*** If a side airbag or a side curtain airbag inflates, a cup holder or other hard object attached on or near the door could be propelled inside the car and hurt someone.
- ***Do not place any objects over the outside edge of a front seat-back.*** Covering the outside edge of a front seat-back, with a non-Acura seat cover for example, could prevent the airbag from inflating properly.

## Carrying Cargo

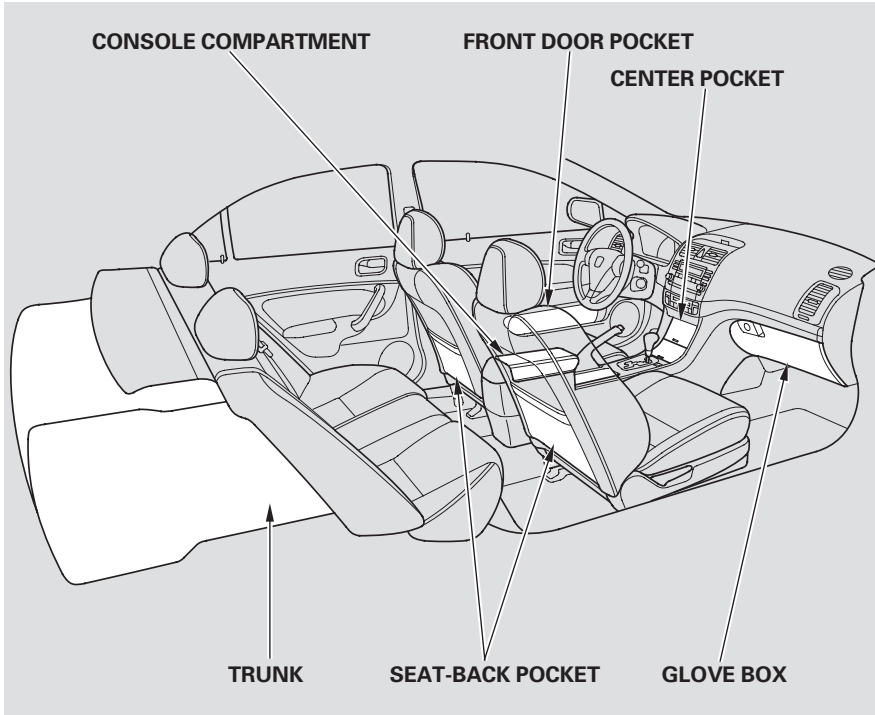

Your car has several convenient storage areas so you can stow cargo safely.

The glove box, and the pockets in the doors and seat-backs, are designed for small, lightweight items. The trunk is intended for larger, heavier items. In addition, the back seat can be folded down to allow you to carry more cargo or longer items.

However, carrying too much cargo, or improperly storing it, can affect your car's handling, stability, stopping distance, and tires, and make it unsafe. Before carrying any type of cargo, be sure to read the following pages.

## Carrying Cargo

### Load Limit

The maximum load limit for your vehicle is 850 lbs (395 kg). This figure includes the total weight of all occupants, cargo, accessories, and the tongue weight if you are towing a trailer.

Following are the steps for determining the correct cargo and luggage load limit.

1. Locate the statement, “the combined weight of occupants and cargo should never exceed 850 lbs (395 kg)” on your vehicle’s placard (on the driver’s doorjamb).
2. Determine the combined weight of the driver and passengers that will be riding in your vehicle. (Five is the seating capacity of your vehicle.)

3. Subtract the combined weight of the driver and passengers from 850 lbs (395 kg).

4. The resulting figure equals the available amount of cargo and luggage load capacity.

For example, if there will be four 150 lbs (70 kg) occupants in your vehicle, the amount of available cargo and luggage load capacity is 250 lbs (115 kg).

$$4 \times 150 \text{ lbs (70 kg)} = 600 \text{ lbs (280 kg)}$$
$$850 \text{ lbs (395 kg)} - 600 \text{ lbs (280 kg)} = 250 \text{ lbs (115 kg)}$$

5. Determine the combined weight of accessories, luggage, and cargo being loaded in the vehicle. The weight may not safely exceed the available cargo and luggage load capacity calculated in step 4 [250 lbs (115 kg) in this example].

### WARNING

Overloading or improper loading can affect handling and stability and cause a crash in which you can be hurt or killed.

Follow all load limits and other loading guidelines in this manual.

6. If your vehicle will be towing a trailer, load from your trailer will be transferred to your vehicle. Consult this manual to determine how this reduces the available cargo and luggage load capacity of your vehicle.

### Carrying Items in the Passenger Compartment

- Store or secure all items that could be thrown around and hurt someone during a crash.
- Do not put any items on top of the rear shelf. They can block your view and be thrown around the car during a crash.
- Be sure items placed on the floor behind the front seats cannot roll under the seats and interfere with the driver's ability to operate the pedals, or with the proper operation of the seats.
- Keep the glove box closed while driving. If it is open, a passenger could injure their knees during a crash or sudden stop.

### Carrying Cargo in the Trunk or on a Roof Top Carrier

- Distribute cargo evenly on the floor of the trunk, placing the heaviest items on the bottom and as far forward as possible.
- If you fold down the back seat, tie down items that could be thrown about the car during a crash or sudden stop.
- If you carry large items that prevent you from closing the trunk lid, exhaust gas can enter the passenger area. To avoid the possibility of **carbon monoxide poisoning**, follow the instructions on page [53](#) .
- If you can carry any items on a roof rack, be sure the total weight of the rack and the items does not exceed the maximum allowable weight. Please contact your Acura dealer for further information.

### Trunk Hooks

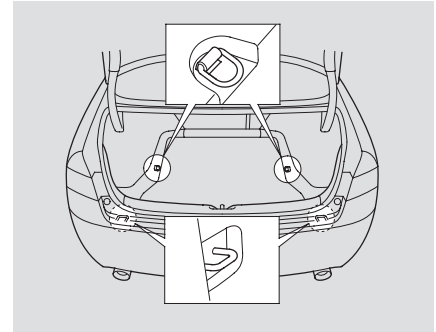

There are hooks on the floor and sides of the trunk. They can be used to install a net for securing items.



This section gives you tips on starting the engine under various conditions, and how to operate the manual and automatic transmissions. It also includes important information on parking your car, the braking system, the vehicle stability assist system, and facts you need if you are planning to tow a trailer.

Preparing to Drive .....	198
Starting the Engine.....	199
Starting in Cold Weather at High Altitude .....	200
6-speed Manual Transmission .....	201
Recommended Shift Points.....	202
Engine Speed Limiter .....	202
Reverse Lockout.....	203
Automatic Transmission.....	204
Shift Lever Position Indicator..	204
Shift Lever Positions .....	204
Engine Speed Limiter .....	209
Shift Lock Release.....	210
Parking.....	211
Parking Tips .....	211
The Braking System.....	212
Brake Wear Indicators.....	212
Brake System Design.....	213
Anti-lock Brakes .....	213
Important Safety Reminders .....	214
ABS Indicator .....	214
Vehicle Stability Assist System....	216
Driving in Bad Weather .....	219
Towing a Trailer .....	221



## Preparing to Drive

---

You should do the following checks and adjustments every day before you drive your car.

1. Make sure all windows, mirrors, and outside lights are clean and unobstructed. Remove frost, snow, or ice.
2. Check that the hood and trunk are fully closed.
3. Visually check the tires. If a tire looks low, use a gauge to check its pressure.
4. Check that any items you may be carrying with you inside are stored properly or fastened down securely.
5. Check the adjustment of the seat (see page [90](#) ).
6. Check the adjustment of the inside and outside mirrors (see page [102](#) ).
7. Check the adjustment of the steering wheel (see page [76](#) ).
8. Make sure the doors are securely closed and locked.
9. Fasten your seat belt. Check that your passengers have fastened their seat belts (see page [15](#) ).
10. Turn the ignition switch ON (II). Check the indicator lights in the instrument panel.
11. Start the engine (see page [199](#) ).
12. Check the gauges and indicator lights in the instrument panel (see page [59](#) ).

1. Apply the parking brake.
2. In cold weather, turn off all electrical accessories to reduce the drain on the battery.
3. *Manual Transmission:*  
Push the clutch pedal down all the way. START (III) does not function unless the clutch pedal is depressed.  
  
*Automatic Transmission:*  
Make sure the shift lever is in Park. Press on the brake pedal.
4. Without touching the accelerator pedal, turn the ignition key to the START (III) position. If the engine does not start right away, do not hold the key in START (III) for more than 15 seconds at a time. Pause for at least 10 seconds before trying again.
5. If the engine does not start within 15 seconds, or starts but stalls right away, repeat step 4 with the accelerator pedal pressed half-way down. If the engine starts, release pressure on the accelerator pedal so the engine does not race.
6. If the engine still does not start, press the accelerator pedal all the way down and hold it there while starting in order to clear flooding. As before, keep the ignition key in the START (III) position for no more than 15 seconds. Return to step 5 if the engine does not start. If it starts, lift your foot off the accelerator pedal so the engine does not race.

## Starting the Engine

---

### **Starting in Cold Weather at High Altitude (Above 8,000 feet/ 2,400 meters)**

An engine is harder to start in cold weather. The thinner air found at high altitude above 8,000 feet (2,400 meters) adds to the problem. Use the following procedure:

1. Turn off all electrical accessories to reduce the drain on the battery.
2. Push the accelerator pedal half-way to the floor and hold it there while starting the engine. Do not hold the ignition key in START (III) for more than 15 seconds. When the engine starts, release the accelerator pedal gradually as the engine speeds up and smooths out.
3. If the engine fails to start in step 2, push the accelerator pedal to the floor and hold it there while you try to start the engine for no more than 15 seconds. If the engine does not start, return to step 2.

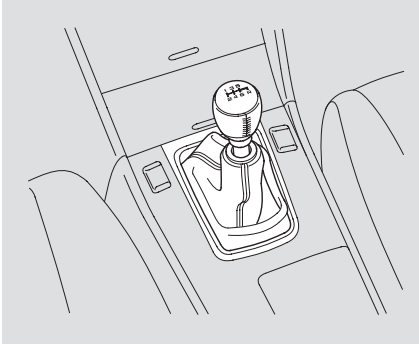

The manual transmission is synchronized in all forward gears for smooth operation. It has a lockout so you cannot accidentally shift from Fifth to Reverse instead of sixth (see page 203) while the car is moving. When shifting up or down, make sure you push the clutch pedal down all the way, shift to the next gear, and let the pedal up gradually. When you are not shifting, do not rest your foot on the clutch pedal. This can cause your clutch to wear out faster.

Come to a full stop before you shift into Reverse. You can damage the transmission by trying to shift into Reverse with the car moving. Push down the clutch pedal, and pause for a few seconds before shifting into Reverse, or shift into one of the forward gears for a moment. This stops the gears so they won't "grind."

When slowing down, you can get extra braking from the engine by shifting to a lower gear. This extra braking can help you maintain a safe speed and prevent your brakes from overheating while going down a steep hill. Before downshifting, make sure engine speed will not go into the tachometer's red zone in the lower gear.

### **⚠ WARNING**

Rapid slowing or speeding-up can cause loss of control on slippery surfaces. If you crash, you can be injured.

Use extra care when driving on slippery surfaces.

## 6-speed Manual Transmission

---

### Recommended Shift Points

Drive in the highest gear that lets the engine run and accelerate smoothly. This will give you the best fuel economy and effective emissions control. The following shift points are recommended:

Shift up	Normal acceleration
1st to 2nd	12 mph (19 km/h)
2nd to 3rd	23 mph (37 km/h)
3rd to 4th	34 mph (54 km/h)
4th to 5th	45 mph (72 km/h)
5th to 6th	56 mph (90 km/h)

### Engine Speed Limiter

If you exceed the maximum speed for the gear you are in, the engine speed will enter into the tachometer's red zone. If this occurs, you may feel the engine cut in and out. This is caused by a limiter in the engine's computer controls. The engine will run normally when you reduce the RPM below the red zone.

Before downshifting, make sure the engine will not go into the tachometer's red zone.

### Reverse Lockout

The 6-speed manual transmission has an electric lockout so you cannot accidentally shift from Fifth to Reverse instead of Sixth while the car is moving. If you cannot shift to Reverse when the car is stopped:

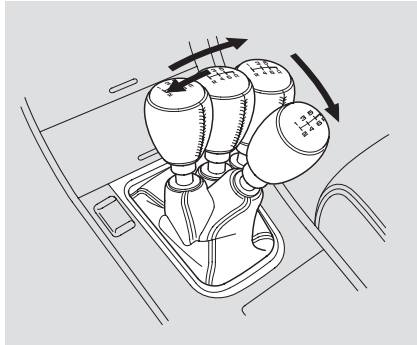

1. With the clutch pedal pressed, move the shift lever to the First/Second gear side of the Neutral gate, then shift to Reverse.

2. If you are still unable to shift to Reverse, apply the parking brake and turn the ignition key to ACCESSORY (I) or LOCK (0).
3. Press the clutch pedal, and shift to Reverse.
4. With the clutch pedal still pressed, start the engine.

If you need to use this procedure to shift to Reverse, your car may be developing a problem. Have the car checked by your Acura dealer.

## Automatic Transmission

Your Acura's transmission has five forward speeds, and is electronically controlled for smoother shifting. It also has a "lock-up" torque converter for better fuel economy. You may feel what seems like another shift when the converter locks.

### Shift Lever Position Indicator

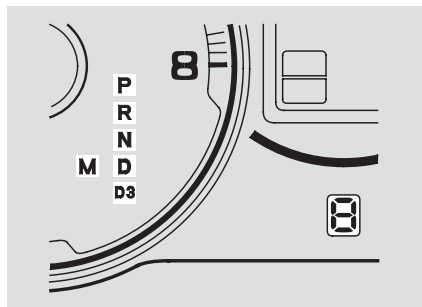

This indicator on the instrument panel shows which position the shift lever is in.

The "D" indicator comes on for a few seconds when you turn the ignition switch ON (II). If it flashes at any time (in any shift position), it indicates a possible problem in the transmission. Avoid rapid acceleration and have the transmission checked by an authorized Acura dealer as soon as possible.

### Shift Lever Positions

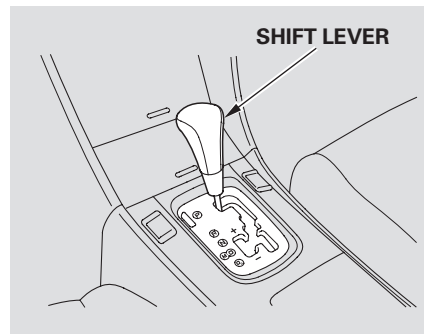

The shift lever has five positions. It must be in Park or Neutral to start the engine. When you are stopped in D, D<sub>3</sub>, N, R or the manual mode, press firmly on the brake pedal and keep your foot off the accelerator pedal.

## Automatic Transmission

To shift from:	Do this:
P to R	Press the brake pedal, then move the shift lever.
R to N N to D D to D <sub>3</sub> D <sub>3</sub> to D D to N N to R R to P	Move the lever.

You cannot shift out of Park with the brake pedal pressed when the ignition switch is in the LOCK (0) or ACCESSORY (I).

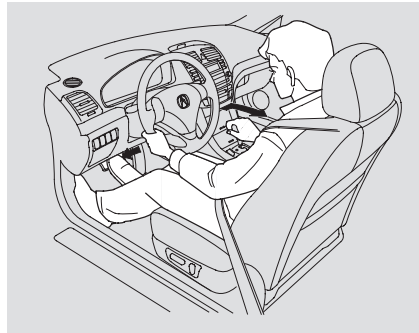

**Park (P)** – This position mechanically locks the transmission. Use Park whenever you are turning off or starting the engine. To shift out of Park, you must press on the brake pedal and have your foot off the accelerator pedal. Move the shift lever to the side to shift out of Park.

If you have done all of the above and still cannot move the lever out of Park, see Shift Lock Release on page 210.

To avoid transmission damage, come to a complete stop before shifting into Park. The shift lever must be in Park before you can remove the key from the ignition switch.

*CONTINUED*



## Automatic Transmission

---

**Reverse (R)** — To shift to Reverse from Park, see the explanation under Park. To shift to Reverse from Neutral, come to a complete stop and then shift.

Your car has a reverse lockout so you cannot accidentally shift to Reverse from Neutral or any other driving position when the car speed exceeds 5–6 mph (8–10 km/h).

If you cannot shift to Reverse when the car is stopped, press the brake pedal and slowly shift to Neutral, and then to Reverse.

If there is a problem in the reverse lockout system, or your car's battery is disconnected or goes dead, you cannot shift to Reverse. (Refer to Shift Lock Release on page [210](#)).

**Neutral (N)** — Use Neutral if you need to restart a stalled engine, or if it is necessary to stop briefly with the engine idling. Shift to Park position if you need to leave the car for any reason. Press on the brake pedal when you are moving the shift lever from Neutral to another gear.

**Drive (D)** — Use this position for your normal driving. The transmission automatically selects a suitable gear for your speed and acceleration.

**Drive (D3)** — This position is similar to D, except only the first three gears are selected. Use D3 when towing a trailer in hilly terrain, or to provide engine braking when going down a steep hill. D3 can also keep the transmission from cycling third, fourth and fifth gears in stop-and-go driving.

For faster acceleration when in D3 or D, you can get the transmission to automatically downshift by pushing the accelerator pedal to the floor. The transmission will shift down one, two or three gears, depending on your speed.

**Sequential SportShift Mode** – With the shift lever in “D” position, you can select the Sequential SportShift Mode to shift gears much like a manual transmission, but without a clutch pedal.

To enter the Sequential SportShift Mode, move the shift lever further to the driver’s side. To return to “D”, move the shift lever to the passenger’s side.

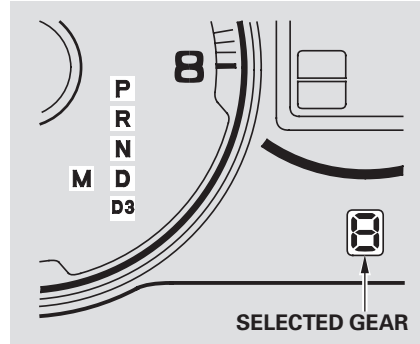

When you move the shift lever from “D” to the Sequential SportShift mode, the display shows the selected gear.

In Sequential SportShift mode, each time you push forward on the shift lever, the transmission will shift to a higher gear. Pull back on the lever to downshift. The number of the gear selected is displayed on the instrument panel (see page [204](#)).

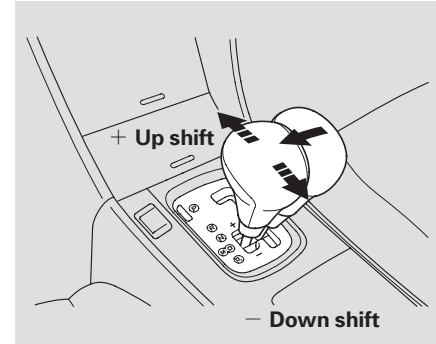

When you accelerate away from a stop, the transmission will be in first gear. The transmission will not automatically upshift. Watch the tachometer and upshift manually before the engine reaches redline.

The transmission remains in the selected gear (5, 4, 3, 2, or 1). There is no automatic downshift when you push the accelerator pedal to the floor.

*CONTINUED*

## Automatic Transmission

---

The transmission may automatically downshift from the higher gear to a lower gear under the following conditions:

- The car speeds drops below
  - 5 → 4 : 33 mph (52 km/h)
  - 4 → 3 : 20 mph (32 km/h)
- If you drive uphill between
  - 5 → 4 : 45–33 mph (72–52 km/h)
  - 4 → 3 : 33–20 mph (52–32 km/h)
  - 3 → 2 : 20–10 mph (32–16 km/h)
- If you press the brake pedal as you drive downhill.

Downshifting gives you more power when climbing, and provides engine braking when going down a steep hill.

The transmission will also shift automatically as the car comes to a complete stop. It will downshift to first gear when the car speed is under 6 mph (10 km/h).

If you try to manually downshift at a speed that would cause the engine to exceed the redline in a lower gear, the transmission will not downshift. The gear indicator will flash the number of the lower gear several times, then return to the higher gear.

If the car speed slows to below the redline of the selected lower gear position while the indicator is flashing, the transmission will downshift and the display will show the selected lower gear.

The table shows the speed ranges for upshifting and downshifting.

To shift from	Speed range
1 → 2	over 0 mph (0 km/h)
2 → 3	over 6 mph (10 km/h)
3 → 4	over 20 mph (32 km/h)
4 → 5	over 33 mph (52 km/h)

To shift from	Speed range
2 → 1	under 31 mph (50 km/h)
3 → 2	under 69 mph (110 km/h)
4 → 3	under 88 mph (140 km/h)
5 → 4	under 131 mph (210 km/h)

### Starting in Second Gear

When you are in Sequential Sportshift mode, and the vehicle is stopped, push forward on the shift lever to shift to second gear. You will see “2” in the display. Starting out in second gear will help to reduce wheelspin in deep snow or on a slippery surface.

### Engine Speed Limiter

If you exceed the maximum speed for the gear you are in, the engine speed will enter into the tachometer’s red zone. If this occurs, you may feel the engine cut in and out. This is caused by a limiter in the engine’s computer controls. The engine will run normally when you reduce the RPM below the red zone.

## Automatic Transmission

### Shift Lock Release

This allows you to move the shift lever out of Park if the normal method of pushing on the brake pedal does not work. This procedure is also used to release the Reverse Lockout.

1. Set the Parking brake.
2. Make sure the key is in the ignition switch LOCK (0) position. [To release the Reverse Lockout, make sure the ignition switch is in the ACCESSORY (I) position.]
3. Put a cloth on the edge of the Shift Lock Release slot cover next to the shift lever. Use a small flat-tipped screwdriver or small metal plate (neither are included in the tool kit) to remove the cover by carefully prying on its edge.

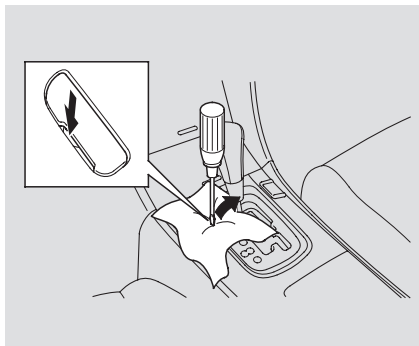

4. Insert the ignition key in the Shift Lock Release slot.
5. Push down on the key while you move the shift lever out of Park to Neutral.

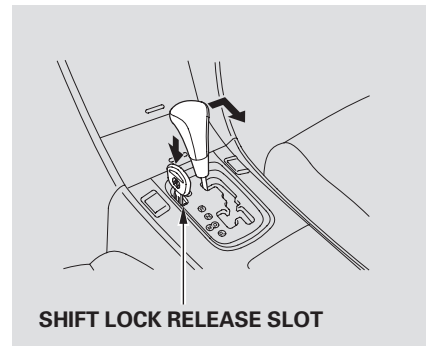

6. Remove the key from the Shift Lock Release slot, then install a new cover. Depress the brake pedal and restart the engine.

If you need to use the Shift Lock Release, it means your car is developing a problem. Have the car checked by your Acura dealer.

Always use the parking brake when you park your car. The indicator on the instrument panel shows that the parking brake is not fully released; it does not indicate that the parking brake is firmly set. Make sure the parking brake is set firmly or your car may roll if it is parked on an incline.

If your car has an automatic transmission, set the parking brake before you put the transmission in Park. This keeps the car from moving and putting pressure on the parking mechanism in the transmission — making it easier to move the shift lever out of Park when you want to drive away.

If the car is facing uphill, turn the front wheels away from the curb. If you have a manual transmission, put it in first gear.

If the car is facing downhill, turn the front wheels toward the curb. If you have a manual transmission, put it in reverse gear.

Make sure the parking brake is fully released before driving away. Driving with the parking brake partially set can overheat or damage the rear brakes.

### **Parking Tips**

- Make sure the moonroof and the windows are closed.
- Turn off the lights.
- Place any packages, valuables, etc., in the trunk or take them with you.
- Lock the doors with the key or the remote transmitter. Check the indicator on the instrument panel to verify that the security system is set.
- Never park over dry leaves, tall grass, or other flammable materials. The three way catalytic converter gets very hot, and could cause these materials to catch on fire.

## The Braking System

---

Your Acura is equipped with disc brakes at all four wheels. A power assist helps reduce the effort needed on the brake pedal. The ABS helps you retain steering control when braking very hard.

Put your foot on the brake pedal only when you intend to brake. Resting your foot on the pedal keeps the brakes applied lightly, causing them to build up heat. Heat build-up can reduce how well your brakes work. It also keeps your brake lights on all the time, confusing drivers behind you.

Constant application of the brakes when going down a long hill builds up heat and reduces their effectiveness. Use the engine to assist the brakes by downshifting to a lower gear and taking your foot off the accelerator pedal.

Check your brakes after driving through deep water. Apply the brakes moderately to see if they feel normal. If not, apply them gently and frequently until they do. Since a longer distance is needed to stop with wet brakes, be extra cautious and alert in your driving.

### **Brake Wear Indicators**

All four brakes have audible brake wear indicators.

When the brake pads need replacing, you will hear a distinctive metallic “screeching” sound when you apply the brakes. If you do not have the brake pads replaced, they will begin screeching all the time.

Your brakes may sometimes squeal or squeak when you apply them lightly. Do not confuse this with the brake wear indicators. They make a very audible “screeching.”

## Brake System Design

The hydraulic system that operates the brakes has two separate circuits. Each circuit works diagonally across the car (the left-front brake is connected with the right-rear brake, etc.). If one circuit should develop a problem, you will still have braking at two wheels.

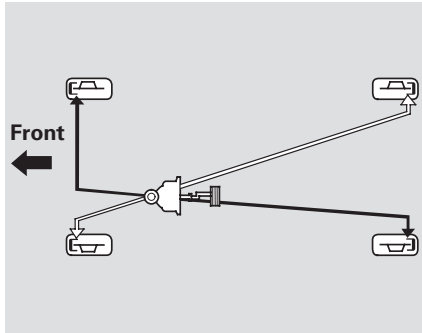

## Anti-lock Brakes

Your car has an Anti-lock Brake System (ABS) as standard equipment. ABS helps to prevent the wheels from locking up and skidding during hard braking, allowing you to retain steering control.

When the front tires skid, you lose steering control; the car continues straight ahead even though you turn the steering wheel. The ABS helps to prevent lock-up and helps you retain steering control by pumping the brakes rapidly; much faster than a person can do it.

The ABS also balances the front-to-rear braking distribution according to car loading.

**You should never pump the brake pedal;** this defeats the purpose of the ABS. Let the ABS work for you by always keeping firm, steady pressure on the brake pedal as you steer away from the hazard. This is sometimes referred to as *"stomp and steer."*

You will feel a pulsation in the brake pedal when the ABS activates, and you may hear some noise. This is normal; it is the ABS rapidly pumping the brakes.

Activation varies with the amount of traction your tires have. On dry pavement, you will need to press on the brake pedal very hard before you activate the ABS. However, you may feel the ABS activate immediately if you are trying to stop on snow or ice.

CONTINUED



## The Braking System

### *Important Safety Reminders*

**ABS does not reduce the time or distance it takes to stop the car;** it only helps with steering control during braking. You should always maintain a safe following distance from other vehicles.

**ABS will not prevent a skid that results from changing direction abruptly,** such as trying to take a corner too fast or making a sudden lane change. Always drive at a safe, prudent speed for the road and weather conditions.

**ABS cannot prevent a loss of stability.** Always steer moderately when you are braking hard. Severe or sharp steering wheel movement can still cause your car to veer into oncoming traffic or off the road.

**A car with ABS may require a longer distance to stop** on loose or uneven surfaces, such as gravel or snow, than a car without anti-lock. Slow down and allow a greater distance between cars under those conditions.

### *ABS Indicator*

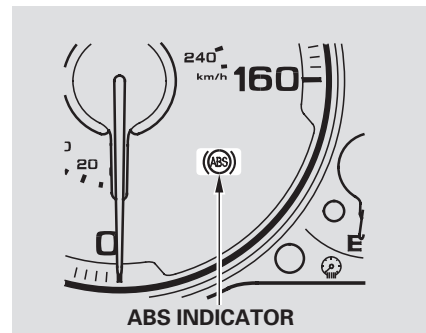

The ABS is self-checking. If anything goes wrong, the ABS indicator on the instrument panel comes on (see page 61). This means the anti-lock function of the braking system has shut down. The brakes still work like a conventional system without anti-lock, providing normal stopping ability. You should have the dealer inspect your car as soon as possible.

If the ABS indicator and the brake system indicator come on together, and the parking brake is fully released, the front-to-rear braking distribution system may also shut down.

Test your brakes as instructed on page [321](#) . If the brakes feel normal, drive slowly and have your car repaired by your dealer as soon as possible. Avoid sudden hard braking which could cause the rear wheels to lock up and possibly lead to a loss of control.

## Vehicle Stability Assist (VSA) System

---

The Vehicle Stability Assist system helps to stabilize the car during cornering if the car turns more or less than desired. It also assists you in maintaining traction while accelerating on loose or slippery road surfaces. It does this by regulating the engine's output, and by selectively applying braking.

When VSA activates, you may notice that the engine does not respond to the accelerator in the same way it does at other times. You will also see the VSA Activation Indicator blink.

### *VSA Activation Indicator*

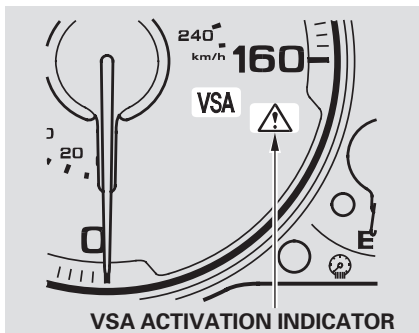

The VSA system cannot enhance the car's driving stability in all situations and does not control your car's entire braking system. It is still your responsibility to drive and corner at reasonable speeds and to leave a sufficient margin of safety.

## Vehicle Stability Assist (VSA) System

### VSA System Indicator

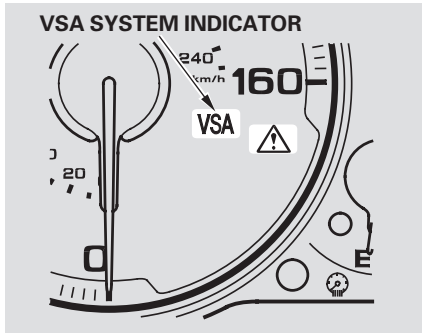

The VSA system indicator (see page 61) comes on and stays on when there is a problem with the VSA system. The VSA Activation indicator will also come on.

The VSA system indicator may come on along with the ABS indicator if there is a problem with the anti-lock brake system.

If the VSA indicator comes on while driving, pull to the side of the road when it is safe and turn off the engine. Reset the system by restarting the engine, and watch the VSA system indicator. If the indicator remains on, or comes back on while driving, have the VSA system inspected by your Acura dealer.

If the indicator does not come on when the ignition switch is turned ON (II), there may be a problem with the VSA system. Have your dealer inspect your car as soon as possible.

Without VSA, your car will have normal braking and cornering ability, but it will not have VSA traction and stability enhancement.

### VSA Off Switch

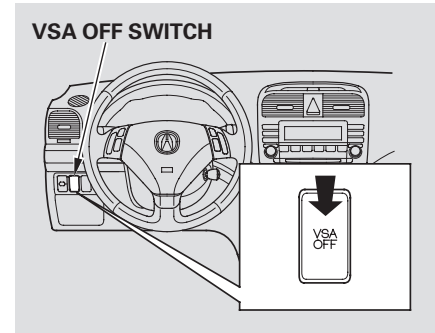

This switch is under the left vent. Press it to turn the Vehicle Stability Assist system on and off.

When VSA is off, the VSA Activation Indicator light comes on as a reminder. Pressing the switch again turns the system back on.

*CONTINUED*

## Vehicle Stability Assist (VSA) System

---

VSA is turned on every time you start the engine, even if you turned it off the last time you drove the car.

### **VSA and Tire Sizes**

Driving with varying tire or wheel sizes may cause the VSA to malfunction. When replacing tires, make sure they are of the same size and type as your original tires (see page [276](#)).

Deactivate the VSA system if you need to drive with the compact spare tire installed (see page [304](#)).

If you install winter tires, make sure they are the same size as those that were originally supplied with your car. Exercise the same caution during winter driving as you would if your car was not equipped with VSA.

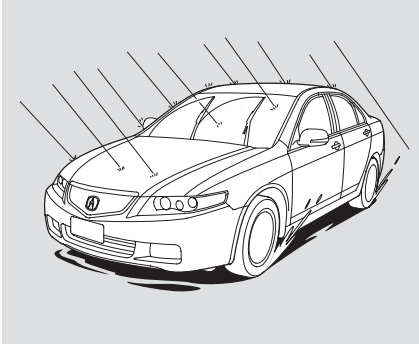

Rain, fog, and snow conditions require a different driving technique because of reduced traction and visibility. Keep your car well-maintained and exercise greater caution when you need to drive in bad weather. The cruise control should not be used in these conditions.

**Driving Technique** — Always drive slower than you would in dry weather. It takes your car longer to react, even in conditions that may seem just barely damp. Apply smooth, even pressure to all the controls. Abrupt steering wheel movements or sudden, hard application of the brakes can cause loss of control in wet weather. Be extra cautious for the first few miles (kilometers) of driving while you adjust to the change in driving conditions. This is especially true in snow. A person can forget some snow-driving techniques during the summer months. Practice is needed to relearn those skills.

Exercise extra caution when driving in rain after a long dry spell. After months of dry weather, the first rains bring oil to the surface of the roadway, making it slippery.

*CONTINUED*

## Driving in Bad Weather

---

**Visibility** — Being able to see clearly in all directions and being visible to other drivers are important in all weather conditions. This is more difficult in bad weather. To be seen more clearly during daylight hours, turn on your headlights.

Inspect your windshield wipers and washers frequently. Keep the windshield washer reservoir full of the proper fluid. Have the windshield wiper blades replaced if they start to streak the windshield or leave parts unwiped. Use the defroster and air conditioning to keep the windows from fogging up on the inside (see pages [119](#) and [126](#)).

**Traction** — Check your tires frequently for wear and proper pressure. Both are important in preventing “hydroplaning” (loss of traction on a wet surface). In the winter, mount snow tires on all four wheels for the best handling.

Watch road conditions carefully, they can change from moment to moment. Wet leaves can be as slippery as ice. “Clear” roads can have patches of ice. Driving conditions can be very hazardous when the outside temperature is near freezing. The road surface can become covered with areas of water puddles mixed with areas of ice, so your traction can change without warning.

Be careful when downshifting. If traction is low, you can lock up the drive wheels for a moment and cause a skid.

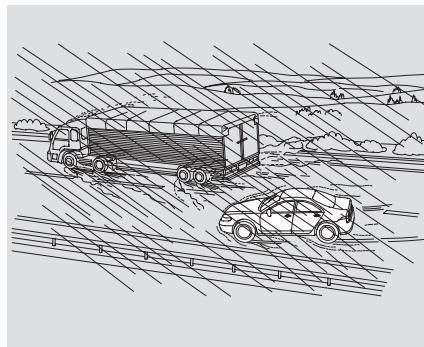

Be very cautious when passing, or being passed by other vehicles. The spray from large vehicles reduces your visibility, and the wind buffeting can cause you to lose control.

Your Acura has been designed primarily to carry passengers and their cargo. You can use it to tow a trailer if you carefully observe the load limits, use the proper equipment, and follow the guidelines in this section.

### Load Limits

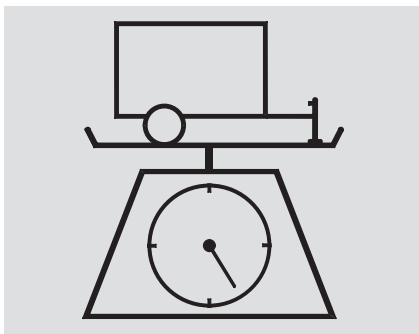

- **Total Trailer Weight:** The total weight of the trailer and everything loaded in it must not exceed 1,000 lbs (450 kg). Towing a load that is too heavy can seriously affect your car's handling and performance. It can also damage the engine and drivetrain.

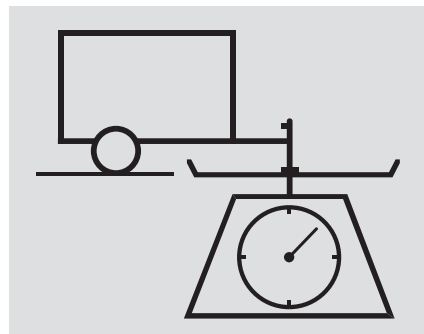

- **Tongue Load:** The weight that the tongue of a fully-loaded trailer puts on the hitch should be approximately 10 percent of the trailer weight. Too little tongue load can make the trailer unstable and cause it to sway. Too much tongue load reduces front-tire traction and steering control.

*CONTINUED*



## Towing a Trailer

---

To achieve a proper tongue load, start by loading 60 percent of the load toward the front of the trailer and 40 percent toward the rear, then re-adjust the load as needed.

- **Gross Vehicle Weight Rating (GVWR):**

The total weight of the car, all occupants, all cargo, and the tongue load must not exceed:

4,300 lbs (1,950 kg)

- **Gross Axle Weight Rating (GAWR):**

The total weight of the car, all occupants, all cargo, and the tongue load must not exceed:

2,335 lbs (1,060 kg)

on the front axle

2,030 lbs (920 kg)

on the rear axle

### **WARNING**

Exceeding load limits or improperly loading your car and trailer can cause a crash in which you can be seriously injured or killed.

Check the loading of your car and trailer carefully before starting to drive.

### **Checking Loads**

The best way to confirm that car and trailer weights are within limits is to have them checked at a public scale.

Using a suitable scale or a special tongue load gauge, check the tongue load the first time you set up a towing combination (a fully-loaded car and trailer), then recheck the tongue load whenever the conditions change.

### **Towing Equipment and Accessories**

Towing can require a variety of equipment, depending on the size of your trailer, how it will be used, and how much load you are towing.

Discuss your needs with your trailer sales or rental agency, and follow the guidelines in the rest of this section. Also make sure that all equipment is properly installed and that it meets federal, state, province, and local regulations.

#### ***Hitches***

Any hitch used on your car must be properly bolted to the underbody.

#### ***Safety Chains***

Always use safety chains. Make sure they are secured to both the trailer and hitch, and that they cross under the tongue so they can catch the trailer if it becomes unhitched. Leave enough slack to allow the

trailer to turn corners easily, but do not let the chains drag on the ground.

#### ***Trailer Brakes***

Acura recommends that any trailer having a total weight of 1,000 lbs (450 kg) or more be equipped with its own electric or surge-type brakes.

If you choose electric brakes, be sure they are electronically actuated. Do not attempt to tap into your car's hydraulic system. No matter how successful it may seem, any attempt to attach trailer brakes to your car's hydraulic system will lower braking effectiveness and create a potential hazard.

See your trailer dealer for more information on installing electric brakes.

*CONTINUED*

## Towing a Trailer

---

### ***Trailer Lights***

All states and Canadian provinces require some type of trailer lights. Check requirements for the areas where you plan to tow.

You can get an optional trailer lighting connector for your car from your Acura dealer.

If you use a converter, you can get the connector and pins that mate with the connector in your car from your Acura dealer.

Since lighting and wiring vary in trailer type and brand, you should also have a qualified mechanic install a suitable connector between the car and the trailer.

Always consult your Acura dealer before connecting the trailer lights to your car's lighting system.

Refer to the following table for the wiring color code.

### *Wiring Color Code for Lighting*

Applicable Light	Wiring Color
Taillight	Red/Black
Brake Light	White/Black
Back-up Light	Green/Black
Right Turn Signal	Green/ Yellow
Left Turn Signal	Green/Blue
Ground	Black

### ***Additional Trailer Equipment***

Many states and Canadian provinces require special outside mirrors when towing a trailer. Even if they don't, you should install special mirrors if you cannot clearly see behind you, or if the trailer creates a blind spot.

Ask your trailer sales or rental agency if any other items are recommended or required for your towing situation.

### **Pre-Tow Checklist**

When preparing to tow, and before driving away, be sure to check the following:

- The car has been properly serviced, and the tires, brakes, suspension, and cooling system are in good operating condition.
  - All weights and loads are within limits (see pages [221](#) and [222](#) ).
  - The hitch, safety chains, and any other attachments are secure.
  - All items on and in the trailer are properly secured and cannot shift while you drive.
  - The lights and brakes on your car and the trailer are working properly.
- Your car tires and spare are properly inflated (see page [274](#) ), and the trailer tires and spare are inflated as recommended by the trailer maker.

## Towing a Trailer

---

### Driving Safely With a Trailer

The added weight, length, and height of a trailer will affect your car's handling and performance, so driving with a trailer requires some special driving skills and techniques.

For your safety and the safety of others, take time to practice driving maneuvers before heading for the open road, and follow the guidelines discussed below.

### *Towing Speeds and Gears*

Drive slower than normal in all driving situations, and obey posted speed limits for cars with trailers. If you have an automatic transmission, use D position when towing a trailer on level roads. D3 is the proper shift lever position to use when towing a trailer in hilly terrain. (See “*Driving on Hills*” in the next page for additional gear information.)

When towing a trailer in the Sequential SportShift mode, select Fourth, Third, Second, or First gear; depending on the vehicle speed and road condition. Do not use Fifth gear.

If the automatic transmission fluid temperature increases and exceeds the specified limit, the transmission will also automatically downshift to the first gear even with the Sequential Sportshift mode. This prevents the automatic transmission from overheating. In this case, the gear position “1” in the instrument panel between tachometer and speedometer blinks about for five seconds, then it stays on.

### ***Making Turns and Braking***

Make turns more slowly and wider than normal. The trailer tracks a smaller arc than your car, and it can hit or run over something the car misses. Allow more time and distance for braking. Do not brake or turn suddenly as this could cause the trailer to jackknife or turn over.

### ***Driving on Hills***

When climbing hills, closely watch your temperature gauge. If it nears the red (Hot) mark, turn the air conditioning off, reduce speed and, if necessary, pull to the side of the road to let the engine cool.

If the automatic transmission shifts frequently within 3rd, 4th, and 5th gears while going up a hill, shift to D3.

If you must stop when facing uphill, use the foot brake or parking brake. Do not try to hold the car in place by pressing on the accelerator, as this can cause the automatic transmission to overheat.

When driving down hills, reduce your speed and shift down to 2nd gear. Do not “ride” the brakes, and remember it will take longer to slow down and stop when towing a trailer.

### ***Handling Crosswinds and Buffeting***

Crosswinds and air turbulence caused by passing trucks can disrupt your steering and cause trailer swaying. When being passed by a large car, keep a constant speed and steer straight ahead. Do not try to make quick steering or braking corrections.

### ***Backing Up***

Always drive slowly and have someone guide you when backing up. Grip the *bottom* of the steering wheel; then turn the wheel to the left to get the trailer to move to the left, and turn the wheel right to move the trailer to the right.

### ***Parking***

Follow all normal precautions when parking, including firmly setting the parking brake and putting the transmission in Park (automatic) or in 1st or Reverse (manual). Also, place wheel chocks at each of the trailer’s tires.



This section explains why it is important to keep your car well maintained and how to follow basic maintenance safety precautions.

This section also includes Maintenance Schedules for normal driving and severe driving conditions, a Maintenance Record, and instructions for simple maintenance tasks you may want to take care of yourself.

If you have the skills and tools to perform more complex maintenance tasks on your Acura, you may want to purchase the Service Manual. See page 351 for information on how to obtain a copy, or see your Acura dealer.

Maintenance Safety.....	230	Hood Latch.....	262
Important Safety Precautions ..	231	Spark Plugs.....	262
Maintenance Schedule.....	232	Replacement.....	262
Required Maintenance Record....	239	Specifications .....	264
Owner Maintenance Checks.....	242	Battery .....	265
Fluid Locations.....	243	Wiper Blades.....	267
Engine Oil.....	244	Air Conditioning System.....	269
Adding Oil.....	244	Dust and Pollen Filter .....	270
Recommended Oil.....	244	Drive Belt.....	272
Synthetic Oil.....	245	Tires .....	273
Additives.....	246	Inflation.....	273
Changing the Oil and Filter.....	246	Inspection .....	275
Cooling System .....	249	Maintenance.....	275
Adding Engine Coolant.....	249	Tire Rotation .....	276
Replacing Engine Coolant .....	251	Replacing Tires and Wheels ...	276
Windshield Washers .....	255	Wheels and Tires.....	277
Transmission Fluid.....	256	Winter Driving .....	278
Automatic		Snow Tires.....	278
Transmission.....	256	Tire Chains.....	278
6-speed Manual		Lights .....	280
Transmission.....	257	Replacing Bulbs .....	282
Brake and Clutch Fluid.....	259	Storing Your Car.....	293
Brake System.....	259		
Clutch System .....	260		
Power Steering.....	260		
Air Cleaner Element.....	261		



## Maintenance Safety

---

Regularly maintaining your car is the best way to protect your investment. Proper maintenance is essential to your safety and the safety of your passengers. It will also reward you with more economical, trouble-free driving, and help reduce air pollution.

### **WARNING**

Improperly maintaining this car or failing to correct a problem before driving can cause a crash in which you can be seriously hurt or killed.

Always follow the inspection and maintenance recommendations and schedules in this owner's manual.

This section includes instructions for simple maintenance tasks, such as checking and adding oil. Any service items not detailed in this section should be performed by an Acura technician or other qualified mechanic.

Some of the most important safety precautions are given here. However, we cannot warn you of every conceivable hazard that can arise in performing maintenance. Only you can decide whether or not you should perform a given task.

### **WARNING**

Failure to properly follow maintenance instructions and precautions can cause you to be seriously hurt or killed.

Always follow the procedures and precautions in this owner's manual.

### **Important Safety Precautions**

Before you begin any maintenance, make sure your car is parked on level ground and that the parking brake is set. Also, be sure the engine is off. This will help to eliminate several potential hazards:

- **Carbon monoxide poisoning from engine exhaust.** Be sure there is adequate ventilation whenever you operate the engine.
- **Burns from hot parts.** Let the engine and exhaust system cool before touching any parts.
- **Injury from moving parts.** Do not run the engine unless instructed to do so.

Read the instructions before you begin, and make sure you have the tools and skills required.

To reduce the possibility of fire or explosion, be careful when working around gasoline or batteries. Use a commercially available degreaser or parts cleaner, not gasoline, to clean parts. Keep cigarettes, sparks, and flames away from the battery and all fuel-related parts.

You should wear eye protection and protective clothing when working near the battery or when using compressed air.

## Maintenance Schedule

---

The Maintenance Schedule specifies how often you should have your car serviced and what things need attention. It is essential that you have your car serviced as scheduled to retain its high level of safety, dependability, and emissions control performance.

The services and time or distance intervals shown in the maintenance schedule assume you will use your car as normal transportation for passengers and their possessions. You should also follow these recommendations:

- Avoid exceeding your car's load limit. This puts excess stress on the engine, brakes, and many other parts of your car. The load limit is shown on the label on the driver's doorjamb.
- Operate your car on reasonable roads within the legal speed limit.
- Drive your car regularly over a distance of several miles (kilometers).
- Always use unleaded gasoline with the proper octane rating (see page [184](#)).

### **Which Schedule to Follow:**

Service your car according to the time and mileage periods on one of the Maintenance Schedules on the following pages.

**U.S. Owners** – Follow the Maintenance Schedule for Severe Conditions if you drive your car **MAINLY** under one or more of the following conditions.

- Driving less than 5 miles (8 km) per trip or, in freezing temperatures, driving less than 10 miles (16 km) per trip.
- Driving in extremely hot [over 90° F (32° C)] conditions.
- Extensive idling or long periods of stop-and-go driving, such as a taxi or a commercial delivery vehicle.

- Trailer towing, driving with a roof rack, or driving in mountainous conditions.
- Driving on muddy, dusty, or deiced roads.

NOTE: If you only *OCCASIONALLY* drive under a “severe” condition, you should follow the Maintenance Schedule for Normal Conditions.

**Canadian Owners** — Follow the Maintenance Schedule for Severe Conditions.

Your authorized Acura dealer knows your car best and can provide competent, efficient service. However, service at a dealer is not mandatory to keep your warranties in effect. Maintenance may be done by any qualified service facility or person who is skilled in this type of automotive service. Keep all the receipts as proof of completion, and have the person who does the work fill out the Maintenance Record. Check your warranty booklet for more information.

We recommend the use of Acura parts and fluids whenever you have maintenance done. These are manufactured to the same high-quality standards as the original components, so you can be confident of their performance and durability.

U.S. Cars:

**Maintenance, replacement, or repair of emissions control devices and systems may be done by any automotive repair establishment or individual using parts that are “certified” to EPA standards.**

According to state and federal regulations, failure to perform maintenance on the items marked with # will not void your emissions warranties. However, Acura recommends that all maintenance services be performed at the recommended time or mileage period to ensure long-term reliability.

Service at the indicated distance or time – whichever comes first.	miles x 1,000	10	20	30	40	50	60	70	80	90	100	110	120	130	140	150	160	170	180	
	km x 1,000	16	32	48	64	80	96	112	128	144	160	176	192	208	224	240	256	272	288	
	months	12	24	36	48	60	72	84	96	108										
Replace engine oil	Every 10,000 miles (16,000 km) or 1 year																			
Replace engine oil filter		•		•		•		•		•		•		•		•		•		•
Check engine oil and coolant	Check oil and coolant at each fuel stop																			
Replace air cleaner element	Every 30,000 miles (48,000 km)																			
Inspect valve clearance	Inspect every 110,000 miles (176,000 km), otherwise adjust only if noisy																			
Replace spark plugs	Every 110,000 miles (176,000 km)																			
Inspect drive belt	Inspect every 30,000 miles (48,000 km) or 2 years																			
Inspect idle speed																			•	
Replace engine coolant	At 120,000 miles (192,000 km) or 10 years, then every 60,000 miles (96,000 km) or 5 years																			
Replace transmission fluid	M/T												•							
	A/T												•*							
Inspect front and rear brakes		•		•		•		•		•		•		•		•		•		•
Replace brake fluid	Every 3 years (independent of mileage)																			
Check parking brake adjustment		•		•		•		•		•		•		•		•		•		•
Replace dust and pollen filter	Every 30,000 miles (48,000 km) or 2 years																			
Rotate tires (Check tire inflation and condition at least once per month)	Rotate tires every 10,000 miles (16,000 km)																			
<b>Visually inspect the following items:</b>																				
Tie rod ends, steering gear box, and boots																				
Suspension components																				
Driveshaft boots																				
Brake hoses and lines (including ABS)		•		•		•		•		•		•		•		•		•		•
All fluid levels and condition of fluids																				
Exhaust system <sup>‡</sup>																				
Fuel lines and connections <sup>‡</sup>																				

# : See information on maintenance and emissions warranty, last column, page 233.

\*: Replace at 120,000 miles (192,000 km) or 6 years, then every 90,000 miles (144,000 km) or 5 years.

Service at the indicated distance or time, whichever comes first. Do the items in **A, B, C, D, E** as required for each distance/time.

**U.S. Owners** — Refer to page 232 to determine which schedule to use.

**Canadian Owners** — Use the Maintenance Schedule for Severe Conditions.

10,000 mi/16,000 km	Do items in A.
20,000 mi/32,000 km/1 yr	Do items in A, B.
30,000 mi/48,000 km	Do items in A, C.
40,000 mi/64,000 km/2 yrs	Do items in A, B.
50,000 mi/80,000 km	Do items in A.
3 yrs	<input type="checkbox"/> Replace brake fluid (independent of mileage).
60,000 mi/96,000 km/3 yrs	Do items in A, B, C.
70,000 mi/112,000 km	Do items in A.
80,000 mi/128,000 km/4 yrs	Do items in A, B.
90,000 mi/144,000 km	Do items in A, C.
100,000 mi/160,000 km/5 yrs	Do items in A, B.
110,000 mi/176,000 km	Do items in A, D.
6 yrs	<input type="checkbox"/> Replace brake fluid (independent of mileage).
120,000 mi/192,000 km/6 yrs	<input type="checkbox"/> Replace manual transmission fluid. <input type="checkbox"/> Replace automatic transmission fluid, then replace every 90,000mi/144,000 km/5 yrs. Do items in A, B, C.
120,000 mi/192,000 km/10 yrs	<input type="checkbox"/> Replace engine coolant, then replace every 60,000mi/96,000 km/5 yrs.
130,000 mi/208,000 km	Do items in A.
140,000 mi/224,000 km/7 yrs	Do items in A, B.
150,000 mi/240,000 km	Do items in A, C.
160,000 mi/256,000 km/8 yrs	Do items in A, B, E.
170,000 mi/272,000 km	Do items in A.
9 yrs	<input type="checkbox"/> Replace brake fluid (independent of mileage).
180,000 mi/288,000 km/15 yrs, then replace every 60,000 mi/ 96,000 km/5 yrs	<input type="checkbox"/> Replace engine coolant.
180,000 mi/288,000 km/9 yrs	Do items in A, B, C.

<b>A</b>	<input type="checkbox"/> Replace engine oil. <input type="checkbox"/> Rotate tires (follow pattern on page 276 ).
<b>B</b>	<input type="checkbox"/> Replace engine oil filter. <input type="checkbox"/> Inspect front and rear brakes. <input type="checkbox"/> Check parking brake adjustment. <input type="checkbox"/> Inspect tie rod ends, steering gear box, and boots. <input type="checkbox"/> Inspect suspension components. <input type="checkbox"/> Inspect driveshaft boots. <input type="checkbox"/> Inspect brake hoses and lines (including ABS). <input type="checkbox"/> Check all fluid levels, condition of fluids, and check for leaks. <input type="checkbox"/> # Inspect exhaust system. <input type="checkbox"/> # Inspect fuel lines and connections.
<b>C</b>	<input type="checkbox"/> Inspect drive belt. <input type="checkbox"/> Replace air cleaner element. <input type="checkbox"/> Replace dust and pollen filter.
<b>D</b>	<input type="checkbox"/> Inspect valve clearance (independent of time). <input type="checkbox"/> Replace spark plugs (independent of time).
<b>E</b>	<input type="checkbox"/> Inspect idle speed.

# : See information on maintenance and emissions warranty, last column, page 233 .

**NOTE:**

- Check engine oil and coolant at each fuel stop.
- Check and adjust valve clearance, cold engine, only if noisy.

Service at the indicated distance or time – whichever comes first.	miles x 1,000	10	20	30	40	50	60	70	80	90	100	110	120	130	140	150	160	170	180	
	km x 1,000	16	32	48	64	80	96	112	128	144	160	176	192	208	224	240	256	272	288	
	months	12		24			36		48		60		72	84		96		108		
Replace engine oil	Every 5,000 miles (8,000 km) or 6 months																			
Replace engine oil filter	Every 10,000 miles (16,000 km) or 1 year																			
Check engine oil and coolant	Check oil and coolant at each fuel stop																			
Replace air cleaner element	Every 15,000 miles (24,000 km) (Use normal schedule except in dusty conditions)																			
Inspect valve clearance	Inspect every 110,000 miles (176,000 km), otherwise adjust only if noisy																			
Replace spark plugs	Every 110,000 miles (176,000 km)																			
Inspect drive belt	Inspect every 30,000 miles (48,000 km) or 2 years																			
Inspect idle speed																		●		
Replace engine coolant	At 120,000 miles (192,000 km) or 10 years, then every 60,000 miles (96,000 km) or 5 years																			
Replace transmission fluid	M/T																			●
	A/T	At 60,000 miles (96,000 km) or 3 years, then every 30,000 miles (48,000 km) or 2 years																		
Inspect front and rear brakes	Inspect every 10,000 miles (16,000 km) or 1 year																			
Replace brake fluid	Every 3 years (independent of mileage)																			
Check parking brake adjustment		●			●			●			●			●			●			●
Replace dust and pollen filter*	Every 30,000 miles (48,000 km) or 2 years																			
Lubricate all hinges, locks, and latches	Lubricate every 10,000 miles (16,000 km) or 1 year																			
Rotate tires (Check tire inflation and condition at least once per month)	Rotate tires every 10,000 miles (16,000 km)																			
<b>Visually inspect the following items:</b>																				
Tie rod ends, steering gear box, and boots	Inspect every 10,000 miles (16,000 km) or 1 year																			
Suspension components																				
Driveshaft boots																				
Brake hoses and lines (including ABS)																				
All fluid levels and condition of fluids																				
Exhaust system <sup>†</sup>		●			●			●			●			●			●			●
Fuel lines and connections <sup>†</sup>																				
Lights and controls, vehicle underbody																				

# : See information on maintenance and emissions warranty, last column, page 233.

\* : See dust and pollen filter on page 270 for replacement information under special driving conditions.

Service at the indicated distance or time, whichever comes first. Do the items in **A, B, C, D, E, F, G, H** as required for each distance/time interval.

**U.S. Owners** – Refer to page 232 to determine which schedule to use.

**Canadian Owners** – Use the Maintenance Schedule for Severe Conditions.

5,000 mi/8,000 km	Do item in A.
10,000 mi/16,000 km	Do items in A, B.
15,000 mi/24,000 km	Do items in A, C.
20,000 mi/32,000 km/1 yr	Do items in A, B, D.
25,000 mi/40,000 km	Do item in A.
30,000 mi/48,000 km	Do items in A, B, C, E.
35,000 mi/56,000 km	Do item in A.
40,000 mi/64,000 km/2 yrs	Do items in A, B, D.
45,000 mi/72,000 km	Do items in A, C.
50,000 mi/80,000 km	Do items in A, B.
55,000 mi/88,000 km	Do item in A.
3 yrs	<input type="checkbox"/> Replace brake fluid (independent of mileage).
60,000 mi/96,000 km/3 yrs	Do items in A, B, C, D, E, F.
60,000 mi/96,000 km/3 yrs, then replace every 30,000mi/ 48,000 km/2yrs	<input type="checkbox"/> Replace automatic transmission fluid.
65,000 mi/104,000 km	Do item in A.
70,000 mi/112,000 km	Do items in A, B.
75,000 mi/120,000 km	Do items in A, C.
80,000 mi/128,000 km/4 yrs	Do items in A, B, D.
85,000 mi/136,000 km	Do item in A.
90,000 mi/144,000 km	Do items in A, B, C, E.
90,000 mi/144,000 km/5 yrs, then replace every 30,000 mi/ 48,000 km/2 yrs	<input type="checkbox"/> Replace automatic transmission fluid.
95,000 mi/152,000 km	Do item in A.
100,000 mi/160,000 km/5 yrs	Do items in A, B, D.
105,000 mi/168,000 km	Do items in A, C.
110,000 mi/176,000 km	Do items in A, B, G.
115,000 mi/184,000 km	Do item in A.
6 yrs	<input type="checkbox"/> Replace brake fluid (independent of mileage).
120,000 mi/192,000 km/6 yrs	Do items in A, B, C, D, E, F.

<b>A</b>	<input type="checkbox"/> Replace engine oil.
<b>B</b>	<input type="checkbox"/> Replace engine oil filter. <input type="checkbox"/> Inspect front and rear brakes. <input type="checkbox"/> Lubricate all hinges, locks, and latches. <input type="checkbox"/> Rotate tires (follow pattern on page 276 ). <input type="checkbox"/> Inspect tie rod ends, steering gear box, and boots. <input type="checkbox"/> Inspect suspension components. <input type="checkbox"/> Inspect drive shaft boots.
<b>C</b>	<input type="checkbox"/> Replace air cleaner element.
<b>D</b>	<input type="checkbox"/> Check parking brake adjustment. <input type="checkbox"/> Inspect brake hoses and lines (including ABS). <input type="checkbox"/> Inspect all fluid levels, condition of fluids, and check for leaks. <input type="checkbox"/> # Inspect exhaust system. <input type="checkbox"/> # Inspect fuel lines and connections. <input type="checkbox"/> Check all lights. <input type="checkbox"/> Inspect the underbody.
<b>E</b>	<input type="checkbox"/> Inspect drive belt. <input type="checkbox"/> Replace dust and pollen filter*.
<b>F</b>	<input type="checkbox"/> Replace transmission fluid (M/T).
<b>G</b>	<input type="checkbox"/> Inspect valve clearance. <input type="checkbox"/> Replace spark plugs.
<b>H</b>	<input type="checkbox"/> Inspect idle speed.

# : See information on maintenance and emissions warranty, last column, page 233 .

\* : See dust and pollen filter on page 270 for replacement information under special driving conditions.



120,000 mi/192,000 km/7 yrs, then replace every 30,000 mi/ 48,000 km/2 yrs	<input type="checkbox"/> Replace automatic transmission fluid.
120,000 mi/192,000 km/10 yrs, then replace every 60,000mi/ 96,000 km/5 yrs	<input type="checkbox"/> Replace engine coolant.
125,000 mi/200,000 km	Do item in A.
130,000 mi/208,000 km	Do items in A, B.
135,000 mi/216,000 km	Do items in A, C.
140,000 mi/224,000 km/7 yrs	Do items in A, B, D.
145,000 mi/232,000 km	Do item in A.
150,000 mi/240,000 km	Do item in A, B, C, E.
150,000 mi/240,000 km/9 yrs, then replace 30,000 mi/ 48,000 km/2 yrs	<input type="checkbox"/> Replace automatic transmission fluid.
155,000 mi/248,000 km	Do item in A.
160,000 mi/256,000 km/8 yrs	Do items in A, B, D, H.
165,000 mi/264,000 km	Do items in A, C.
170,000 mi/272,000 km	Do items in A, B.
175,000 mi/280,000 km	Do item in A.
9 yrs	<input type="checkbox"/> Replace brake fluid (independent of mileage).
180,000 mi/288,000 km/9 yrs	Do items in A, B, C, D, E, F.
180,000 mi/288,000 km/11 yrs, then replace every 30,000 mi/ 48,000 km/2 yrs	<input type="checkbox"/> Replace automatic transmission fluid.
180,000 mi/288,000 km/15 yrs, then replace every 60,000 mi/ 96,000 km/5 yrs	<input type="checkbox"/> Replace engine coolant.

## NOTE:

- Check engine oil and coolant at each fuel stop.
- Check and adjust valve clearance, cold engine, only if noisy.

## Required Maintenance Record (for Normal and Severe Schedules)

You or the servicing dealer can record all completed maintenance here, whether you follow the schedule for normal conditions (page 234) or severe conditions (page 236). Keep the receipts for all work done on your car.

<b>5,000 mi</b> 8,000 km	Signature or dealer stamp	mi/km
		Date
<b>10,000 mi</b> 16,000 km		mi/km
		Date
<b>15,000 mi</b> 24,000 km		mi/km
		Date
<b>20,000 mi</b> 32,000 km (or 1 year)		mi/km
		Date
<b>25,000 mi</b> 40,000 km		mi/km
		Date
<b>30,000 mi</b> 48,000 km		mi/km
		Date

<b>35,000 mi</b> 56,000 km	Signature or dealer stamp	mi/km
		Date
<b>40,000 mi</b> 64,000 km (or 2 years)		mi/km
		Date
<b>45,000 mi</b> 72,000 km		mi/km
		Date
<b>50,000 mi</b> 80,000 km		mi/km
		Date
<b>55,000 mi</b> 88,000 km		mi/km
		Date
<b>60,000 mi</b> 96,000 km (or 3 years)		mi/km
		Date

## Required Maintenance Record (for Normal and Severe Schedules)

---

<b>65,000 mi</b> 104,000 km	Signature or dealer stamp	mi/km
		Date
<b>70,000 mi</b> 112,000 km		mi/km
		Date
<b>75,000 mi</b> 120,000 km		mi/km
		Date
<b>80,000 mi</b> 128,000 km (or 4 years)		mi/km
		Date
<b>85,000 mi</b> 136,000 km		mi/km
		Date
<b>90,000 mi</b> 144,000 km		mi/km
		Date

<b>95,000 mi</b> 152,000 km	Signature or dealer stamp	mi/km
		Date
<b>100,000 mi</b> 160,000 km (or 5 years)		mi/km
		Date
<b>105,000 mi</b> 168,000 km		mi/km
		Date
<b>110,000 mi</b> 176,000 km		mi/km
		Date
<b>115,000 mi</b> 184,000 km		
		Date
<b>120,000 mi</b> 192,000 km (or 6 years)		mi/km
		Date

## Required Maintenance Record (for Normal and Severe Schedules)

<b>125,000 mi</b> 200,000 km	Signature or dealer stamp	mi/km
		Date
<b>130,000 mi</b> 208,000 km		mi/km
		Date
<b>135,000 mi</b> 216,000 km		mi/km
		Date
<b>140,000 mi</b> 224,000 km (or 7 years)		mi/km
		Date
<b>145,000 mi</b> 232,000 km		mi/km
		Date
<b>150,000 mi</b> 240,000 km		mi/km
		Date

<b>155,000 mi</b> 248,000 km	Signature or dealer stamp	mi/km
		Date
<b>160,000 mi</b> 256,000 km (or 8 years)		mi/km
		Date
<b>165,000 mi</b> 264,000 km		mi/km
		Date
<b>170,000 mi</b> 272,000 km		mi/km
		Date
<b>175,000 mi</b> 280,000 km		mi/km
		Date
<b>180,000 mi</b> 288,000 km (or 9 years)		mi/km
		Date

## Owner Maintenance Checks

---

You should check the following items at the specified intervals. If you are unsure of how to perform any check, turn to the page given.

- Engine oil level — Check every time you fill the fuel tank. See page [187](#).
- Engine coolant level — Check the radiator reserve tank every time you fill the fuel tank. See page [189](#).
- Windshield washer fluid — Check the level in the reservoir monthly. If weather conditions cause you to use the washers frequently, check the reservoir each time you stop for fuel. See page [255](#).
- Automatic transmission — Check the fluid level monthly. See page [256](#).
- Brakes — Check the fluid level monthly. See page [259](#).
- Tires — Check the tire pressure monthly. Examine the tread for wear and foreign objects. See page [273](#).
- Lights — Check the operation of the headlights, parking lights, taillights, high-mount brake light, turn signals, brake lights, and license plate light monthly. See page [280](#).

# Fluid Locations

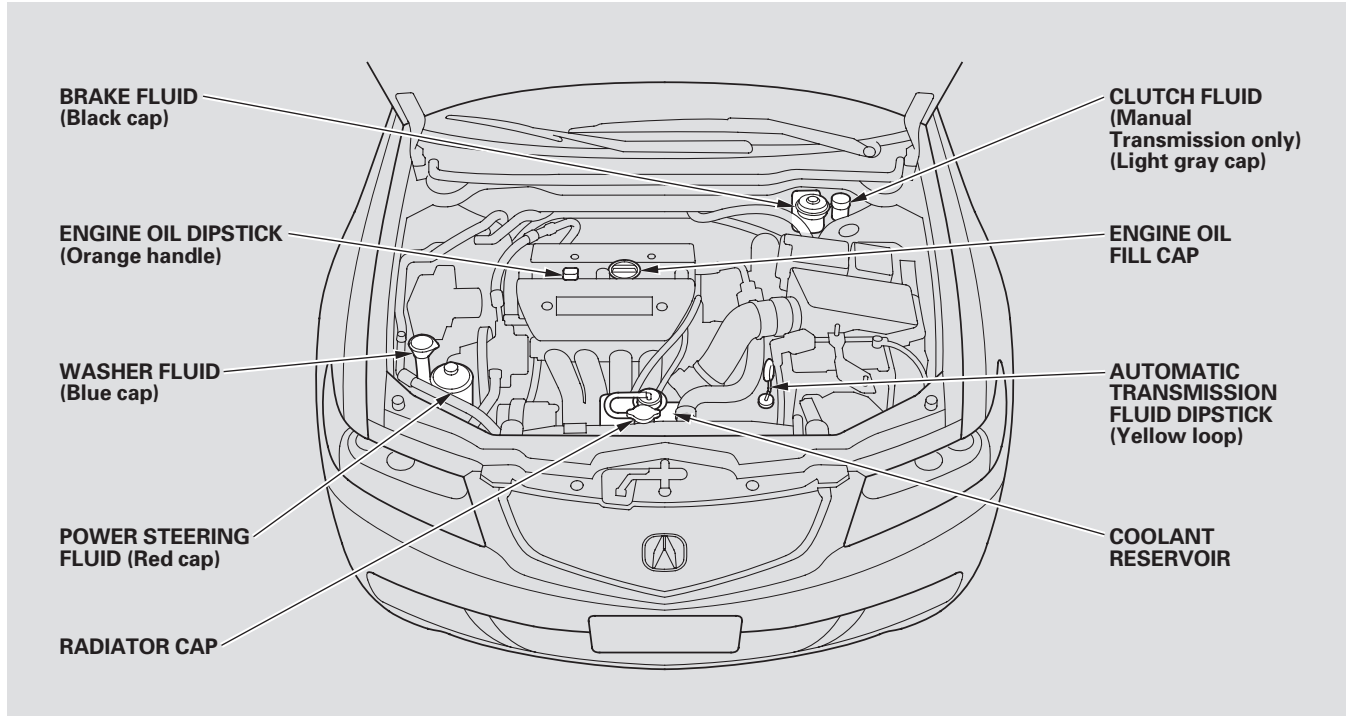

# Engine Oil

---

## Adding Oil

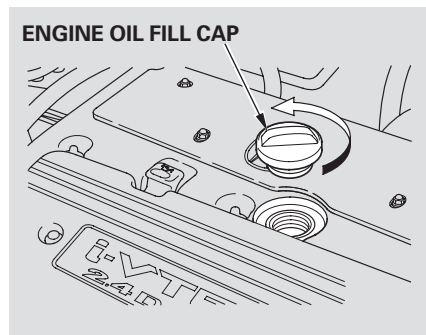

To add oil, unscrew and remove the engine oil fill cap on top of the valve cover. Pour in the oil, and install the engine oil fill cap. Tighten it securely. Wait a few minutes and recheck the oil level. Do not fill above the upper mark; you could damage the engine.

Pour the oil slowly and carefully so you do not spill. Clean up any spills immediately. Spilled oil could damage components in the engine compartment.

## Recommended Oil

Oil is a major contributor to your engine's performance and longevity. Always use a premium-grade 5W-30 detergent oil displaying the API Certification Seal. This seal indicates the oil is energy conserving, and that it meets the American Petroleum Institute's latest requirements.

Honda Motor Oil is the preferred 5W-30 lubricant for your vehicle. It is highly recommended that you use Honda Motor Oil in your vehicle for optimum engine protection.

Make sure the API Certification Seal says “For Gasoline Engines.”



The oil's viscosity or weight is provided on the container's label. Select the oil for your car according to this chart.

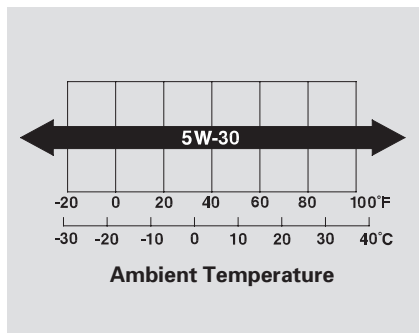

5W-30 oil is formulated for year-round protection of your Acura, to improve cold weather starting, and to help your engine use less fuel.

### Synthetic Oil

You may use a synthetic motor oil if it meets the same requirements given for a conventional motor oil: it displays the API Certification Seal, and it is the proper weight as shown on the chart. When using synthetic oil, you must follow the oil and filter change intervals given in the maintenance schedule.



# Engine Oil

---

## Additives

Your Acura does not require any oil additives. Additives may adversely affect your engine's or transmission's performance and durability.

## Changing the Oil and Filter

Always change the oil and filter according to the time and distance (miles/kilometers) recommendations in the maintenance schedule. The oil and filter collect contaminants that can damage your engine if they are not removed regularly.

Changing the oil and filter requires special tools and access from underneath the car. The car should be raised on a service station-type hydraulic lift for this service. Unless you have the knowledge and proper equipment, you should have this maintenance done by a skilled mechanic.

1. Run the engine until it reaches normal operating temperature, then shut it off.

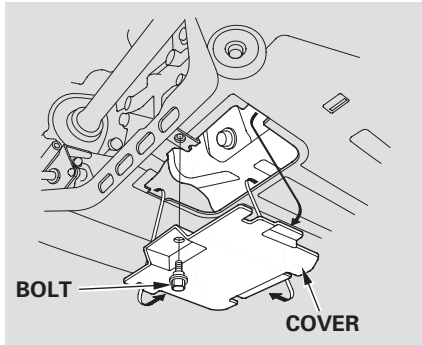

2. Open the hood and remove the engine oil fill cap.
3. Remove the bolt with a wrench, then remove the maintenance cover under the vehicle.

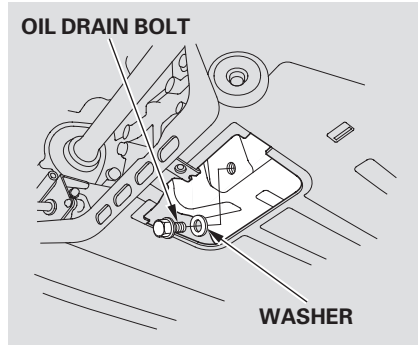

4. Remove the oil drain bolt and washer from the bottom of the engine. Drain the oil into an appropriate container.

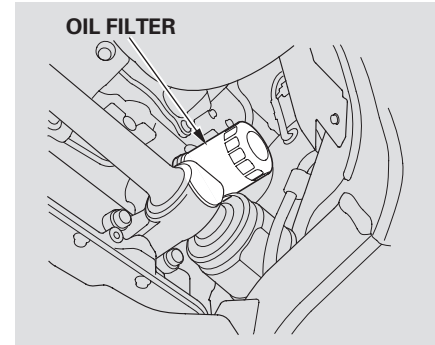

5. Remove the oil filter and let the remaining oil drain. A special wrench (available from your Acura dealer) is required to remove the filter.
6. Install a new oil filter according to instructions that come with it.

*CONTINUED*

## Engine Oil

---

- Put a new washer on the drain bolt, then reinstall the drain bolt.  
Tighten it to:  
33 lbf-ft (45 N·m , 4.6 kgf·m)
- Refill the engine with the recommended oil.  
  
Engine oil change capacity  
(including filter):  
4.4 US qt (4.2 ℓ)
- Replace the engine oil fill cap.  
Start the engine. The oil pressure indicator light should go out within five seconds. If it does not, turn off the engine and reinspect your work.
- Let the engine run for several minutes, then check the drain bolt and oil filter for leaks.
- Turn off the engine, let it sit for several minutes, then check the oil level. If necessary, add oil to bring the level to the upper mark on the dipstick.
- Install the maintenance cover and tighten the bolt securely.

### NOTICE

*Improper disposal of engine oil can be harmful to the environment. If you change your own oil, please dispose of the used oil properly. Put it in a sealed container and take it to a recycling center. Do not discard it in a trash bin or dump it on the ground.*

### Adding Engine Coolant

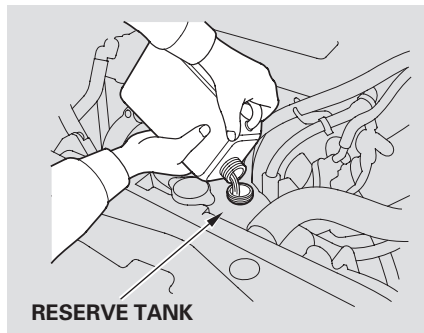

If the coolant level in the reserve tank is at or below the MIN line, add coolant to bring it up to the MAX line. Inspect the cooling system for leaks. The coolant you add should always be a mixture of 50 percent antifreeze and 50 percent water. Never add straight antifreeze or plain water.

Always use Honda All Season Antifreeze/Coolant Type 2. This coolant is pre-mixed with 50 percent antifreeze and 50 percent water. It does not require any additional mixing. If it is not available, you may use another major-brand non-silicate coolant as a temporary replacement. Make sure it is a high-quality coolant recommended for aluminum engines. However, continued use of any non-Honda coolant can result in corrosion, causing the cooling system to malfunction or fail. Have the cooling system flushed and refilled with Honda antifreeze/coolant as soon as possible.

If the reserve tank is completely empty, you should also check the coolant level in the radiator.

### **⚠ WARNING**

Removing the radiator cap while the engine is hot can cause the coolant to spray out, seriously scalding you.

Always let the engine and radiator cool down before removing the radiator cap.

*CONTINUED*

## Cooling System

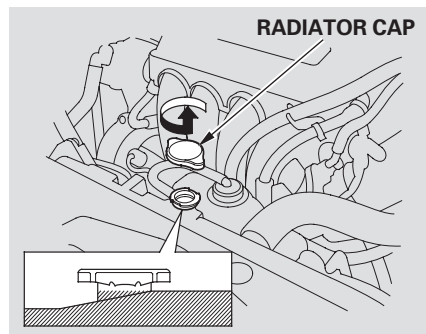

1. Make sure the engine and radiator are cool.
2. Turn the radiator cap counter-clockwise, without pressing down on it, until it stops. This relieves any pressure remaining in the cooling system.
3. Remove the radiator cap by pushing down and turning counterclockwise.

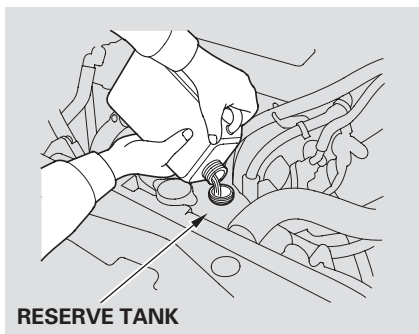

4. The coolant level should be up to the base of the filler neck. Add coolant if it is low.

Pour the coolant slowly and carefully so you do not spill. Clean up any spills immediately. Spilled coolant could damage components in the engine compartment.

5. Put the radiator cap back on. Tighten it fully.
6. Pour coolant into the reserve tank. Fill it to halfway between the MAX and MIN marks. Put the cap back on the reserve tank.

Do not add any rust inhibitors or other additives to your car's cooling system. They may not be compatible with the coolant or engine components.

### Replacing Engine Coolant

The cooling system should be completely drained and refilled with new coolant according to the time and distance recommendations in the maintenance schedule. Only use Honda All Season Antifreeze/Coolant Type 2.

Draining the coolant requires access to the underside of the car. Unless you have the tools and knowledge, you should have this maintenance done by a skilled mechanic.

1. Open the hood. Make sure the engine and radiator are cool to the touch.

Turn the ignition to ON (II). Make sure the DUAL indicator is off. Set the temperature of the climate control system to its upper limit "Hi". Then turn off the ignition, and remove the key.

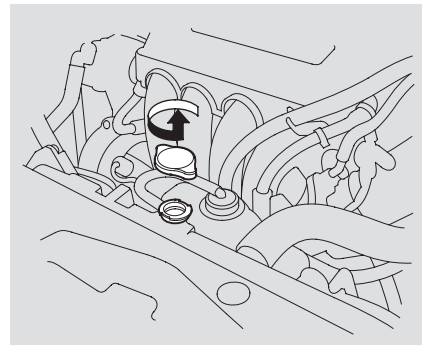

2. Remove the radiator cap.

*CONTINUED*

## Cooling System

---

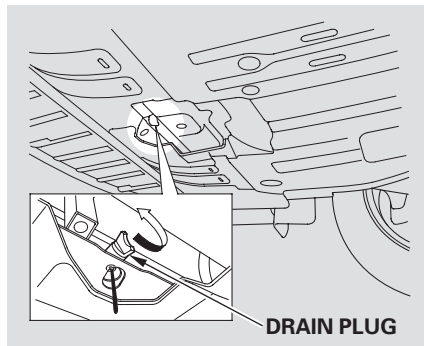

3. Loosen the drain plug on the bottom of the radiator. The coolant will drain through the splash guard. Drain the coolant into an appropriate container.

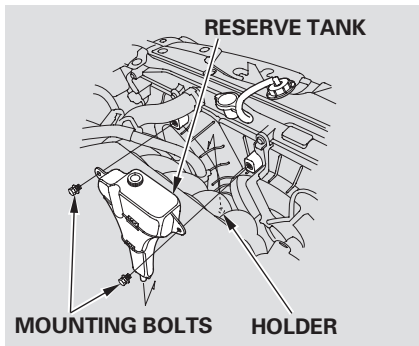

4. Remove the two reserve tank mounting bolts with a wrench.
5. Remove the reserve tank from its holder by pulling it straight up. Drain the coolant into an appropriate container, then put the tank back in its holder. Install the mounting bolts securely.

6. When the coolant stops draining, tighten the drain plug at the bottom of the radiator.

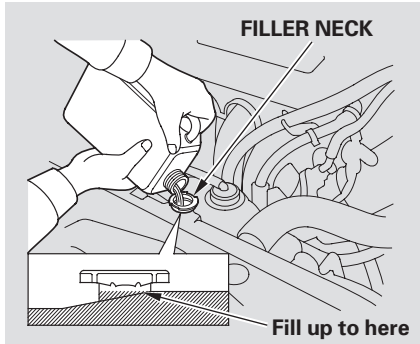

7. Pour Honda All Season Antifreeze/Coolant Type 2 into the radiator up to the base of the filler neck. This coolant is a mixture of 50 percent antifreeze and 50 percent water. Pre-mixing is not required.

The cooling system capacity is:

*With manual transmission:*

1.43 US gal (5.4 l)

*With automatic transmission:*

1.40 US gal (5.3 l)

8. Start the engine, let it run for about 30 seconds, then turn it off.
9. Fill the radiator with coolant up to the base of the filler neck.

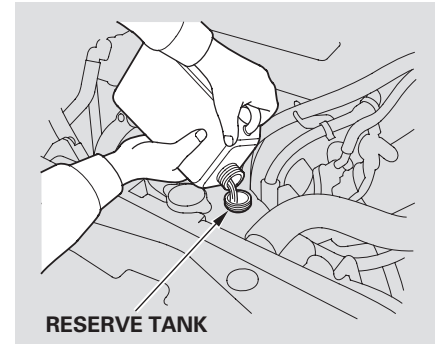

10. Fill the reserve tank to the MAX mark. Install the reserve tank cap.
11. Install the radiator cap, and tighten it to the first stop.
12. Start the engine, let it run until the radiator cooling fan comes on at least twice, then turn it off.

*CONTINUED*



## Cooling System

---

13. Remove the radiator cap. Pour coolant into the radiator up to the base of the filler neck and into the reserve tank up to the MAX mark.
14. Start the engine and hold it at 1,500 rpm until the cooling fan comes on. Turn off the engine. Check the coolant level in the radiator and add coolant if needed.
15. Install the radiator cap, and tighten it fully.
16. If necessary, fill the reserve tank to the MAX mark. Install the reserve tank cap.

Check the level in the windshield washer reservoir at least monthly during normal usage. In bad weather, when you use the washers often, check the level every time you stop for fuel.

The windshield washer reservoir is located behind the right headlight.

Check the reservoir's fluid level by removing the cap and looking at the level gauge attached to the cap.

### **Canadian Models**

The low washer level indicator will light when the level is low (see page 64).

Fill the reservoir with a good-quality windshield washer fluid. This increases the cleaning capability and prevents freezing in cold weather.

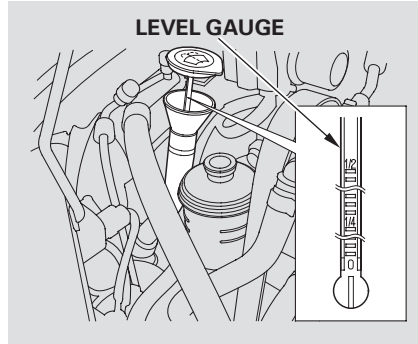

When you refill the reservoir, clean the edges of the windshield wiper blades with windshield washer fluid on a clean cloth. This will help to condition the blade edges.

### **NOTICE**

*Do not use engine antifreeze or a vinegar/water solution in the windshield washer reservoir.*

*Antifreeze can damage your car's paint, while a vinegar/water solution can damage the windshield washer pump.*

*Use only commercially-available windshield washer fluid.*

# Transmission Fluid

## Automatic Transmission

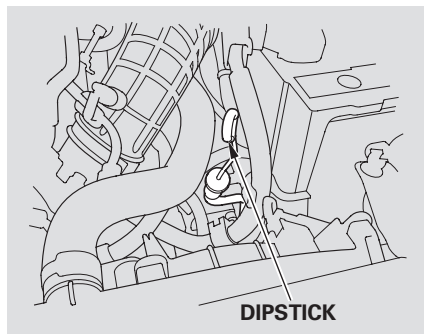

Check the fluid level with the engine at normal operating temperature.

1. Park the car on level ground. Shut off the engine.
2. Remove the dipstick (yellow loop) from the transmission, and wipe it with a clean cloth.

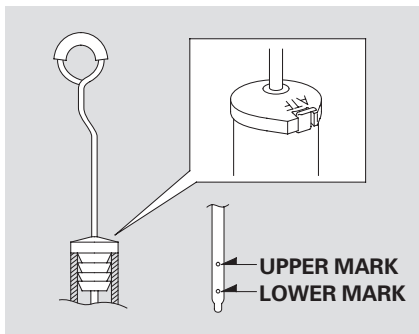

3. Insert the dipstick all the way into the transmission securely as shown in the illustration. Make sure the notch in the rubber cap fits in the dipstick guide and that you push the dipstick in all the way.

4. Remove the dipstick and check the fluid level. It should be between the upper and lower marks.
5. If the level is below the lower mark, add fluid into the dipstick tube to bring it to the upper mark.

Pour the fluid slowly and carefully so you do not spill. Clean up any spills immediately. Spilled fluid could damage components in the engine compartment.

Always use Honda ATF-Z1 (Automatic Transmission Fluid). If it is not available, you may use a DEXRON® III automatic transmission fluid as a temporary replacement. However, continued use can affect shift quality. Have the transmission flushed and refilled with Honda ATF-Z1 as soon as it is convenient.

To thoroughly flush the transmission, the technician should drain and refill it with Honda ATF-Z1, then drive the vehicle a short distance. Do this three times. Then drain and refill the transmission a final time.

6. Insert the dipstick all the way back into the transmission securely as shown in the illustration. Make sure the notch fits in the dipstick guide and the dipstick is down all the way.

The transmission should be drained and refilled with new fluid according to the time and distance recommendations in the maintenance schedule.

If you are not sure how to add fluid, contact your Acura dealer.

### 6-speed Manual Transmission

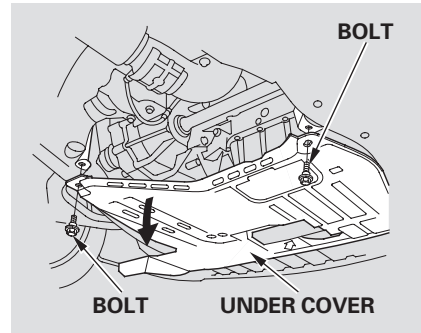

Check the fluid level with the transmission at normal operating temperature and the car sitting on level ground.

To check the transmission fluid level, remove the two bolts, then pull down the left part of the under cover.

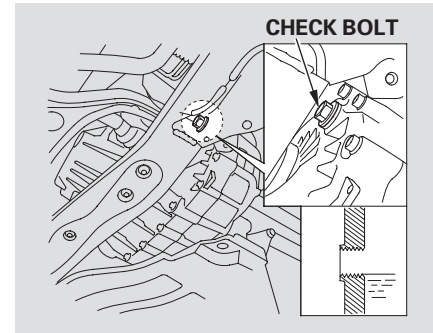

Remove the check bolt and look for transmission fluid coming out of the bolt hole. If a small amount of fluid drips out of the bolt hole, reinstall the check bolt.

*CONTINUED*

## Transmission Fluid

---

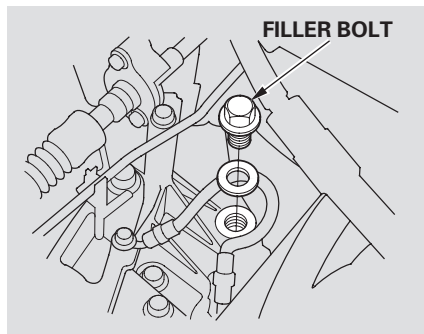

If no fluid comes out, remove the filler bolt. Slowly add Honda Manual Transmission Fluid (MTF) until it starts to run out of the check bolt hole. Let the fluid run out until it stops, then reinstall the check bolt and the filler bolt.

After checking and adding the fluid, put the under cover back in place and tighten the bolts securely.

Pour the fluid to the filler hole slowly and carefully so you do not spill. Clean up any spills immediately. Spilled fluid could damage components in the engine compartment.

If Honda MTF is not available, you may use an SAE 10W-30 or 10W-40 viscosity motor oil with the API Certification seal that says "FOR GASOLINE ENGINES" as a temporary replacement. However, motor oil does not contain the proper additives, and continued use can cause stiffer shifting. Replace as soon as it is convenient.

The transmission should be drained and refilled with new fluid according to the time and distance recommendations in the maintenance schedule.

If you are not sure how to check and add fluid, contact your Acura dealer.

Check the fluid level in the reservoirs monthly. There are up to two reservoirs, depending on the model. They are:

- Brake fluid reservoir (all models)
- Clutch fluid reservoir (manual transmission only)

The brake fluid should be replaced according to the time recommendation in the maintenance schedule.

Always use Honda Heavy Duty Brake Fluid DOT 3. If it is not available, you should use only DOT 3 or DOT 4 fluid, from a sealed container, as a temporary replacement. However, the use of any non-Honda brake fluid can cause corrosion and decrease the life of the system. Have the brake system flushed and refilled with Honda Heavy Duty Brake Fluid DOT 3 as soon as possible.

Pour the fluid slowly and carefully so you do not spill. Clean up any spills immediately. Spilled fluid could damage components in the engine compartment.

Brake fluid marked DOT 5 is not compatible with your car's braking system and can cause extensive damage.

### Brake System

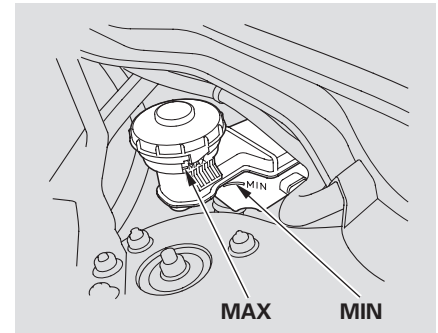

The fluid level should be between the MIN and MAX marks on the side of the reservoir. If the level is at or below the MIN mark, your brake system needs attention. Have the brake system inspected for leaks or worn brake pads.

## Brake and Clutch Fluid, Power Steering

### Clutch System

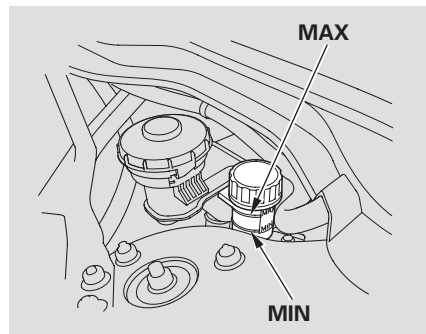

The fluid level should be between the MIN and MAX marks on the side of the reservoir. If it is not, add brake fluid to bring it up to that level. Use the same fluid specified for the brake system.

Low fluid level can indicate a leak in the clutch system. Have this system inspected as soon as possible.

### Power Steering

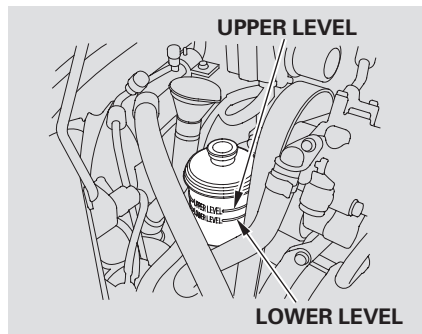

Check the level when the engine is cold. Look at the side of the reservoir. The fluid should be between the UPPER LEVEL and LOWER LEVEL. If it is below the LOWER LEVEL, add power steering fluid to the UPPER LEVEL.

Always use Honda Power Steering Fluid. If it is not available, you may use another power steering fluid as an emergency replacement. However, continued use can cause increased wear and poor steering in cold weather. Have the power steering system flushed and refilled with Honda PSF as soon as possible.

A low power steering fluid level can indicate a leak in the system. Check the fluid level frequently, and have the system inspected as soon as possible.

#### **NOTICE**

*Turning the steering wheel to full left or right lock and holding it there can damage the power steering pump.*

## Air Cleaner Element

The air cleaner element should be replaced according to the distance recommendation in the maintenance schedule.

### **Replacement**

The air cleaner element is inside the air cleaner housing on the driver's side of the engine compartment.

To replace it:

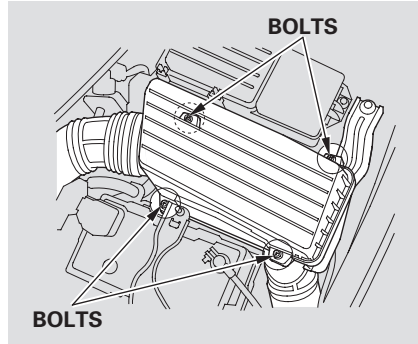

1. Loosen the four bolts, and remove the air cleaner housing cover.
2. Remove the old air cleaner element.
3. Carefully clean the inside of the air cleaner housing with a damp rag.

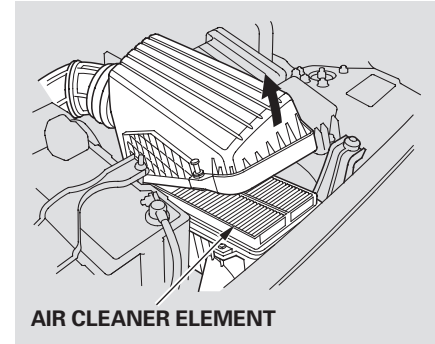

4. Place the new air cleaner element in the air cleaner housing.
5. Reinstall the air cleaner housing cover, and tighten the four bolts.



# Hood Latch, Spark Plugs

## Hood Latch

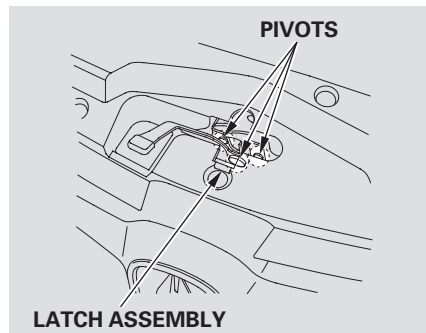

Clean the hood latch assembly with a mild cleaner, then lubricate it with a multipurpose grease. Lubricate all the moving parts (as shown), including the pivot. Follow the time and distance recommendations in the Maintenance Schedule. If you are not sure how to clean and grease the latch, contact your Acura dealer.

## Spark Plugs

The spark plugs in your car are a special iridium-tipped design for longer life. The spark plugs should be replaced according to the distance recommendation in the maintenance schedule.

## Replacement

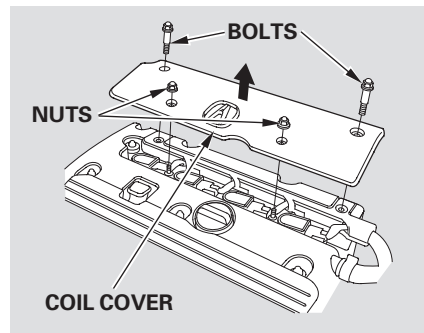

1. Remove the two nuts and two bolts with a wrench, then remove the coil cover.

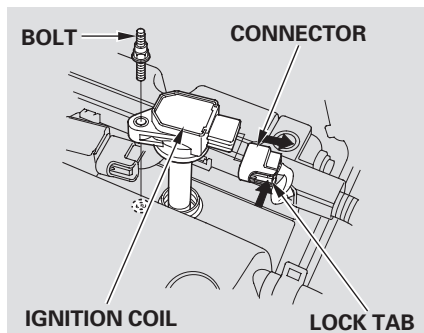

2. Clean up any dirt and oil that have collected around the ignition coils.
3. Use a wrench to remove the bolt holding the ignition coil. Pull the ignition coil up slightly.
4. Disconnect the wire connector from the ignition coil by pushing on the lock tab and pulling on the connector. Pull on the plastic connector, not the wires.

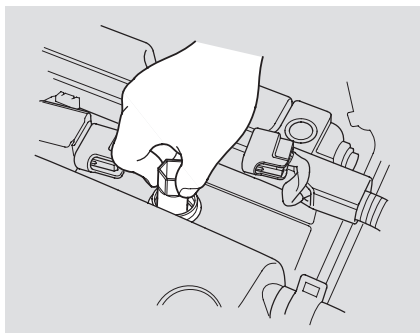

5. Remove the ignition coil.
6. Remove the spark plug with a five-eighths inch (16 mm) spark plug socket.
7. Put the new spark plug into the socket, then screw it into the hole. Screw it in by hand so you do not crossthread it.

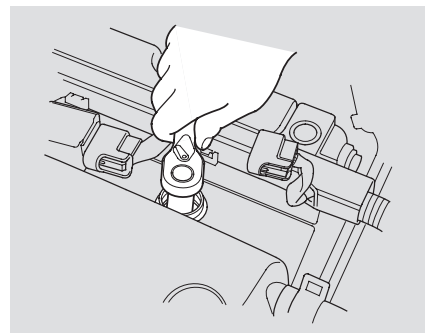

8. Torque the spark plug. (If you do not have a torque wrench, tighten the spark plug two-thirds of a turn after it contacts the cylinder head.)  
Tightening torque:  
13 lbf·ft (18 N·m , 1.8 kgf·m)

*CONTINUED*

## Spark Plugs

---

### NOTICE

*Tighten the spark plugs carefully. A spark plug that is too loose can overheat and damage the engine. Overtightening can cause damage to the threads in the cylinder head.*

9. Install the ignition coil into the hole.
10. Connect the wire connector to the ignition coil. Make sure it locks in place.
11. Push the ignition coil down all the way. Install the bolt.
12. Repeat this procedure for the other three spark plugs.
13. Reinstall the coil cover, and tighten the two nuts and two bolts securely.

### Specifications:

NGK: IZFR6K-11  
DENSO: SKJ20DR-M11

Check the condition of your car's battery monthly. You should check the color of the test indicator window, and for corrosion on the terminals.

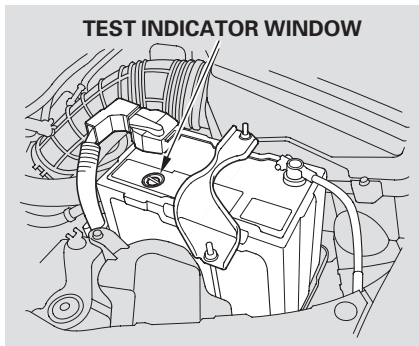

Check the battery condition by looking at the test indicator window on the battery. The label on the battery explains the test indicator's colors.

Check the battery terminals for corrosion (a white or yellowish powder). To remove it, cover the terminals with a solution of baking soda and water. It will bubble up and turn brown. When this stops, wash it off with plain water. Dry off the battery with a cloth or paper towel. Coat the terminals with grease to help prevent future corrosion.

**WARNING:** Battery posts, terminals, and related accessories contain lead and lead compounds. **Wash hands after handling.**

*CONTINUED*

## Battery

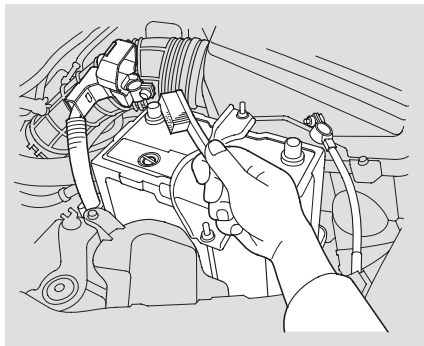

If the terminals are severely corroded, clean them with baking soda and water. Then use a wrench to loosen and remove the cables from the terminals. Always disconnect the negative (–) cable first and reconnect it last. Clean the battery terminals with a terminal cleaning tool or wire brush. Reconnect and tighten the cables, then coat the terminals with grease.

If you need to connect the battery to a charger, disconnect both cables to prevent damage to the car's electrical system.

### **⚠ WARNING**

The battery gives off explosive hydrogen gas during normal operation.

A spark or flame can cause the battery to explode with enough force to kill or seriously hurt you.

Wear protective clothing and a face shield, or have a skilled mechanic do the battery maintenance.

### **NOTICE**

*Charging the battery with the cables connected can seriously damage your car's electronic controls. Detach the battery cables before connecting the battery to a charger.*

If your car's battery is disconnected or goes dead, the audio system, the driver's window AUTO function, and the navigation system (if equipped) will be disabled.

- To restore the audio system, enter the audio system anti-theft code (see page [172](#)).
- To restore the driver's window AUTO function, see page [99](#).
- To restore the navigation system, enter the navigation system security code (see System Security in the Navigation System Owner's manual).

Check the condition of the wiper blades at least every six months. Look for signs of cracking in the rubber, or areas that are getting hard. Replace the blades if you find these signs, or if they leave streaks and unwiped areas when used.

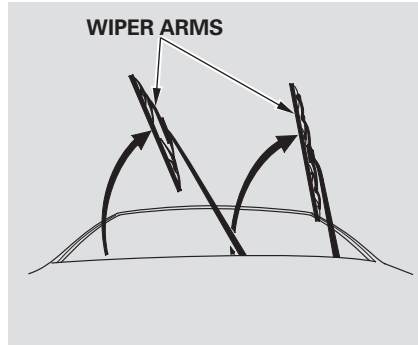

To replace the blade:

1. Raise the wiper arm off the windshield.  
Raise the driver's side first, then the passenger's side.

### NOTICE

*Do not open the hood when the wiper arms are raised, or you will damage the hood and the arms.*

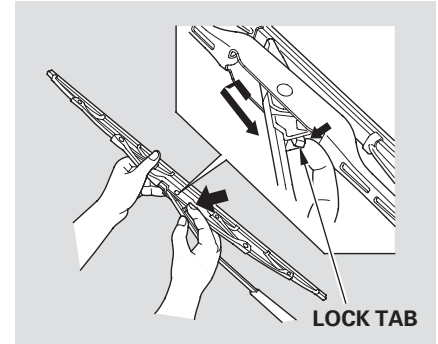

2. Disconnect the blade assembly from the wiper arm by pushing in the lock tab. Hold the lock tab in while you push the blade assembly toward the base of the arm.

CONTINUED

## Wiper Blades

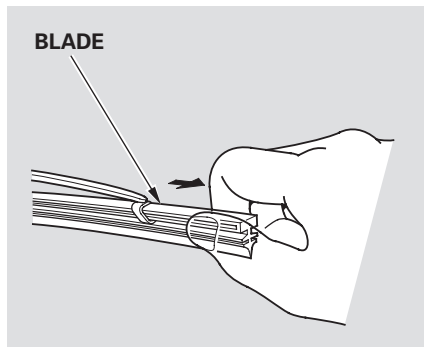

3. Remove the blade from its holder by grasping the tabbed end of the blade. Pull firmly until the tabs come out of the holder.

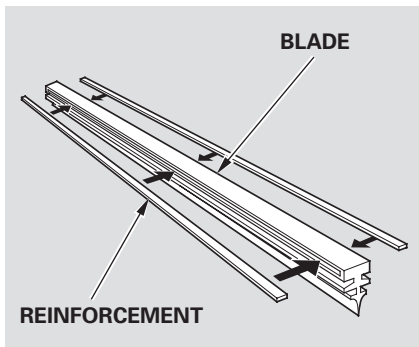

4. Examine the new wiper blades. If they have no plastic or metal reinforcement along the back edge, remove the metal reinforcement strips from the old wiper blade and install them in the slots along the edge of the new blade.

5. Slide the new wiper blade into the holder until the tabs lock.
6. Slide the wiper blade assembly onto the wiper arm. Make sure it locks in place.
7. Lower the wiper arm down against the windshield. Lower the passenger's side first, then the driver's side.

Your car's air conditioning is a sealed system. Any major maintenance, such as recharging, should be done by a qualified mechanic. You can do a couple of things to make sure the air conditioning works efficiently.

Periodically check the engine's radiator and air conditioning condenser for leaves, insects, and dirt stuck to the front surface. These block the air flow and reduce cooling efficiency. Use a light spray from a hose or a soft brush to remove them.

### NOTICE

*The condenser and radiator fins bend easily. Only use a low-pressure spray or soft-bristle brush to clean them.*

**AIR CONDITIONING CONDENSER**

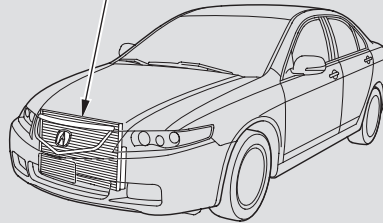

Run the air conditioning at least once a week during the cold weather months. Run it for at least ten minutes while you are driving at a steady speed with the engine at normal operating temperature. This circulates the lubricating oil contained in the refrigerant.

If the air conditioning does not get as cold as before, have your dealer check the system. Recharge the system with Refrigerant HFC-134a (R-134a). (See Specifications on page 334.)

### NOTICE

*Whenever you have the air conditioning system serviced, make sure the service facility uses a refrigerant recycling system. This system captures the refrigerant for reuse. Releasing refrigerant into the atmosphere can damage the environment.*



## Dust and Pollen Filter

---

The dust and pollen filter removes pollen and dust that is brought in from the outside through the heating and cooling system.

This filter should be replaced every 30,000 miles (48,000 km) under normal conditions. It should be replaced every 15,000 miles (24,000 km) if you drive primarily in urban areas that have high concentrations of soot in the air from industry and diesel-powered vehicles. Replace it more often if air flow from the climate control system becomes less than usual.

### *Replacement*

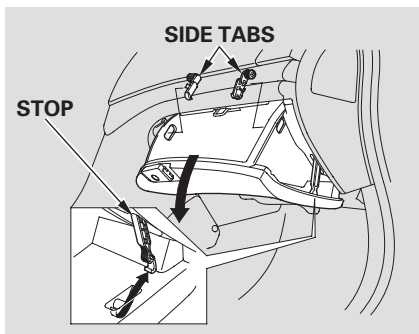

The dust and pollen filter is behind the glove box.

To replace it:

1. Open the glove box, and remove its contents.

2. Push the stop on the right side of the glove box to detach it from the glove box.
3. Remove the side tabs by carefully prying them out with a screwdriver, then pivot the glove box out of the way.

## Dust and Pollen Filter

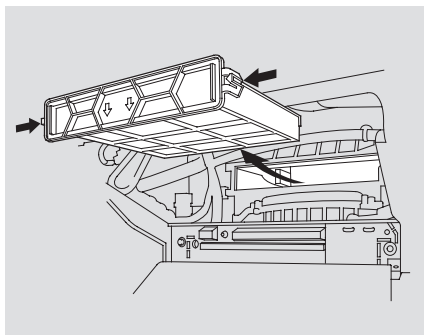

4. Push in the tabs on the corners of the dust and pollen filter case. Pull out the case.

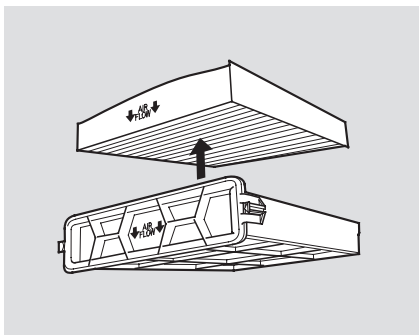

5. Remove the filter from the case.
6. Install the new filter in the case. Make sure the arrows of the "AIR FLOW" marks on the filter point to the air flow direction (downward).

7. Install the case. Make sure both tabs "click" into place.

8. Install the glove box stop and side tabs, then reinstall the contents, and close the glove box.

If you are not sure how to replace the dust and pollen filter, have it replaced by your Acura dealer.

## Drive Belt

---

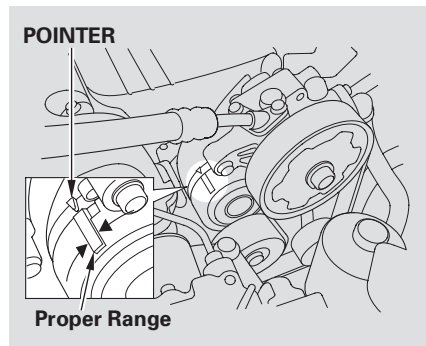

Check the condition of the drive belt. Examine the edges of the belt for cracks or fraying.

An auto-tensioner adjusts the tension of the drive belt. The pointer on the auto-tensioner should be in the proper range. It should be checked according to the time and distance recommendations in the maintenance schedule.

If the pointer is out of this range or you see signs of wear, have the drive belt replaced by your Acura dealer as soon as possible.

To safely operate your car, your tires must be the proper type and size, in good condition with adequate tread, and correctly inflated. The following pages give more detailed information on how and when to check air pressure, how to inspect your tires for damage and wear, and what to do when your tires need to be replaced.

### **WARNING**

Using tires that are excessively worn or improperly inflated can cause a crash in which you can be seriously hurt or killed.

Follow all instructions in this owner's manual regarding tire inflation and maintenance.

### **Inflation**

Keeping the tires properly inflated provides the best combination of handling, tread life, and riding comfort. Underinflated tires wear unevenly, adversely affect handling and fuel economy, and are more likely to fail from being overheated. Overinflated tires can make your car ride more harshly, are more prone to damage from road hazards, and wear unevenly.

We recommend that you visually check your tires every day. If you think a tire might be low, check it immediately with a tire gauge.

Use a gauge to measure the air pressure at least once a month. Even tires that are in good condition may lose one to two psi (10 to 20 kPa, 0.1 to 0.2 kgf/cm<sup>2</sup>) per month. Remember to check the spare tire at the same time you check all the other tires.

Check the pressure in the tires when they are cold. This means the car has been parked for at least three hours. If you have to drive the car before checking the tire pressure, the tires can still be considered "cold" if you drive less than 1 mile (1.6 km).

Add or release air, if needed, to match the recommended cold tire pressures on page [274](#).

*CONTINUED*

# Tires

---

If you check the pressure when the tires are hot [the car has been driven several miles (kilometers)], you will see readings 4 to 6 psi (30 to 40 kPa, 0.3 to 0.4 kgf/cm<sup>2</sup>) higher than the cold reading. This is normal. Do not let air out to match the specified cold pressure. The tire will be underinflated.

You should get your own tire pressure gauge and use it whenever you check your tire pressures. This will make it easier for you to tell if a pressure loss is due to a tire problem and not due to a variation between gauges.

## ***Recommended Tire Pressures for Normal Driving***

The following chart shows the recommended cold tire pressures for most normal driving conditions and speeds. Tire pressures for high speed driving are the same as for normal driving.

Tire Size	Cold Tire Pressure for Normal Driving
P215/50R17 93V	Front: 32 psi (220 kPa , 2.2 kgf/cm <sup>2</sup> )  Rear: 30 psi (210 kPa , 2.1 kgf/cm <sup>2</sup> )

The compact spare tire pressure is:  
60 psi (420 kPa , 4.2 kgf/cm<sup>2</sup>)

For convenience, the recommended tire sizes and cold air pressures are on a label on the driver's doorjamb. For additional technical information about your tires, see page [339](#) .

Tubeless tires have some ability to self-seal if they are punctured. However, because leakage is often very slow, you should look closely for punctures if a tire starts losing pressure.

## Inspection

Every time you check inflation, you should also examine the tires for damage, foreign objects, and wear.

You should look for:

- Bumps or bulges in the tread or side of the tire. Replace the tire if you find either of these conditions.
- Cuts, splits, or cracks in the side of the tire. Replace the tire if you can see fabric or cord.
- Excessive tread wear.

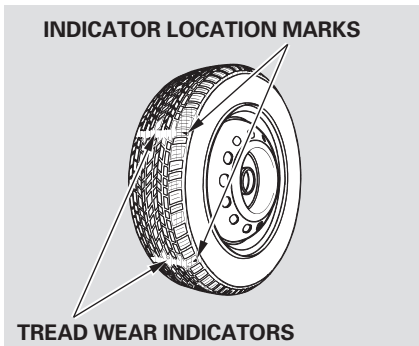

Your car's tires have wear indicators molded into the tread. When the tread wears down to that point, you will see a 1/2 inch (12.7 mm) wide band running across the tread. This shows there is less than 1/16 inch (1.6 mm) of tread left on the tire. A tire that is this worn gives very little traction on wet roads. You should replace the tire if you can see the tread wear indicator in three or more places around the tire.

## Maintenance

In addition to proper inflation, correct wheel alignment helps to decrease tire wear. If you find a tire is worn unevenly, have your dealer check the wheel alignment.

The tires were properly balanced by the factory. They may need to be rebalanced at some time before they are worn out. Have your dealer check the tires if you feel a consistent vibration while driving. A tire should always be rebalanced if it is removed from the wheel for repair.

*CONTINUED*

# Tires

Make sure the installer balances the wheels when you have new tires installed. This increases riding comfort and tire life. Your car's original tires were dynamic or "spin" balanced at the factory. For best results, have the installer perform a dynamic balance.

## NOTICE

*Improper wheel weights can damage your car's aluminum wheels. Use only genuine Acura wheel weights for balancing.*

## Tire Rotation

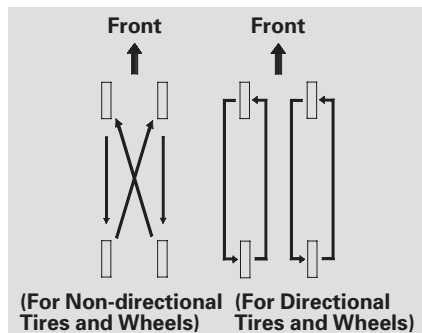

To help increase tire life and distribute wear more evenly, you should have the tires rotated every 10,000 miles (16,000 km). Move the tires to the positions shown in the chart each time they are rotated.

When shopping for replacement tires, you may find that some tires are "directional." This means they are designed to rotate only in one direction. If you use directional tires,

they should be rotated only front-to-back.

## Replacing Tires and Wheels

The tires that came with your car were selected to match the performance capabilities of the car while providing the best combination of handling, ride comfort, and long life. You should replace them with radial tires of the same size, load range, speed rating, and maximum cold tire pressure rating (as shown on the tire's sidewall). Mixing radial and bias-ply tires on your car can reduce its braking ability, traction, and steering accuracy.

## **⚠ WARNING**

Installing improper tires on your car can affect handling and stability. This can cause a crash in which you can be seriously hurt or killed.

Always use the size and type of tires recommended in this owner's manual.

It is best to replace all four tires at the same time. If that is not possible or necessary, then replace the two front tires or the two rear tires as a pair. Replacing just one tire can seriously affect your car's handling.

The ABS works by comparing the speed of the wheels. When replacing tires, use the same size originally supplied with the car. Tire size and construction can affect wheel speed and may cause the system to work inconsistently.

If you ever need to replace a wheel, make sure the wheel's specifications match those of the original wheel that came on your car. Replacement wheels are available at your Acura dealer.

## **Wheels and Tires**

Wheel:

17 x 7 JJ

Tire:

P215/50R17 93V

See page [337](#) for information about DOT Tire Quality Grading.



# Tires

---

## **Winter Driving**

Tires that are marked “M+S” or “All Season” on the sidewall have an all-weather tread design. They should be suitable for most winter driving conditions. Tires without these markings are designed for optimum traction in dry conditions. They may not provide adequate performance in winter driving. For the best performance in snowy or icy conditions, you should install snow tires or tire chains. They may be required by local laws under certain conditions.

## ***Snow Tires***

If you mount snow tires on your Acura, make sure they are radial tires of the same size and load range as the original tires. Mount snow tires on all four wheels to balance your car’s handling in all weather conditions. Keep in mind the traction provided by snow tires on dry roads may not be as high as your car’s original equipment tires. You should drive cautiously even when the roads are clear. Check with the tire dealer for maximum speed recommendations.

## ***Tire Chains***

Mount snow chains on your tires when required by driving conditions or local laws. Install them only on the front tires.

Because your car has limited tire clearance, Acura strongly recommends using the chains listed below, made by Security Chain Company (SCC).

CH2412T

These chains are the only ones that have been approved by Acura for use on your car. Since Acura cannot test all chains, you must be personally responsible for proper selection, installation, and use of snow chains.

The chains listed here are available at many auto supply stores. For a complete list of stores, visit the SCC website at [www.scc-chain.com](http://www.scc-chain.com). When installing chains, follow the manufacturer's instructions, and mount them as tightly as you can. Drive slowly with chains installed.

### **WARNING**

Using the wrong chains, or not properly installing chains, can damage the brake lines and cause a crash in which you can be seriously injured or killed.

Follow all instructions in this owner's manual regarding the selection and use of tire chains.

If you ever hear the chains contacting the body or chassis, stop and investigate. If the chains have loosened, retighten them. Make sure they do not contact the brake lines or suspension.

Remove the chains as soon as you begin driving on cleared roads.

## Lights

---

Check the operation of your car's exterior lights at least once a month. A burned out bulb can create an unsafe condition by reducing your car's visibility and the ability to signal your intentions to other drivers.

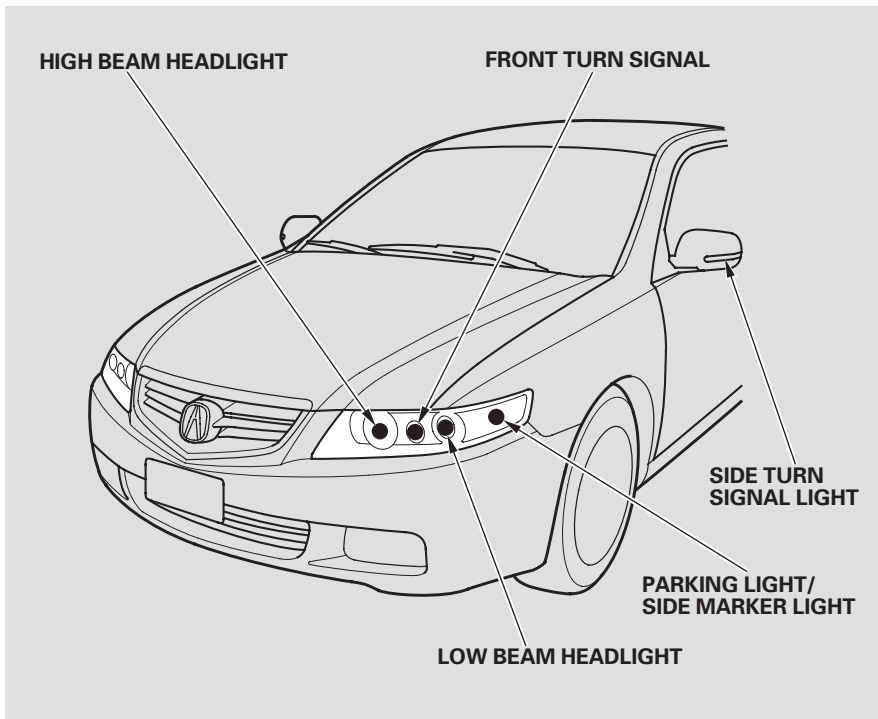

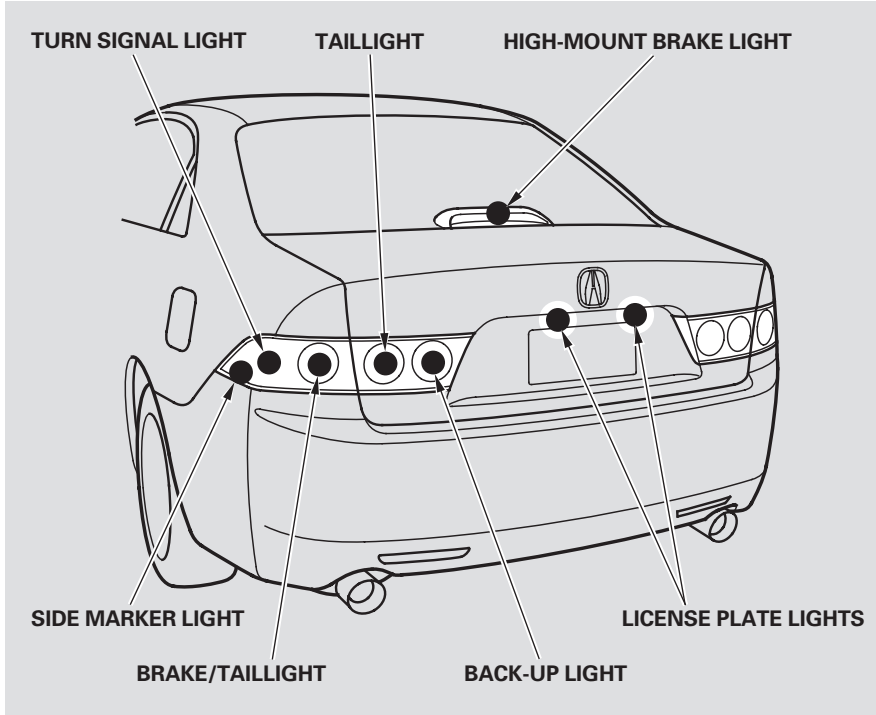

Check the following:

- Headlights (low and high beam)
- Parking lights
- Taillights
- Brake lights
- High-mount brake light
- Turn signals
- Back-up lights
- Hazard light function
- License plate light
- Side marker lights
- Daytime running lights  
(Canadian models)

If you find any bulbs are burned out, replace them as soon as possible. Refer to the chart on page [335](#) to determine what type of replacement bulb is needed.

# Lights

---

## Headlight Aiming

The headlights were properly aimed when your car was new. If you regularly carry heavy items in the trunk or pull a trailer, readjustment may be required. Adjustment of the headlights should be performed by an Acura technician or other qualified mechanic.

## Low Beam Headlight Bulb Replacement

The low beam headlight bulbs are a type of high voltage discharge tube. High voltage can remain in the circuit even with the light switch off and the key removed. Because of this, you should not attempt to examine or change a low beam headlight bulb yourself. If a low beam headlight bulb fails, take the car to your dealer to have it replaced.

## Replacing a High Beam Headlight Bulb

Halogen bulbs are used for the high beam headlight bulbs. When replacing a high beam headlight bulb, handle it by its base and protect the glass from contact with your skin or hard objects. If you touch the glass, clean it with denatured alcohol and a clean cloth.

### **NOTICE**

*Halogen headlight bulbs get very hot when lit. Oil, perspiration, or a scratch on the glass can cause the bulb to overheat and shatter.*

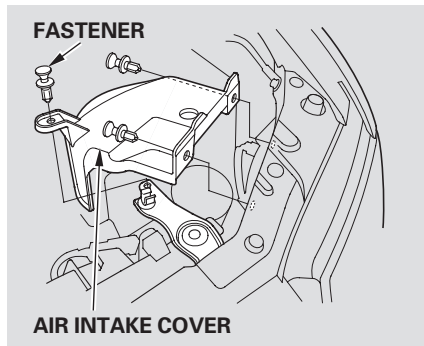

1. Open the hood. If you need to change a bulb on the driver's side, undo the three fasteners and remove the air intake cover.

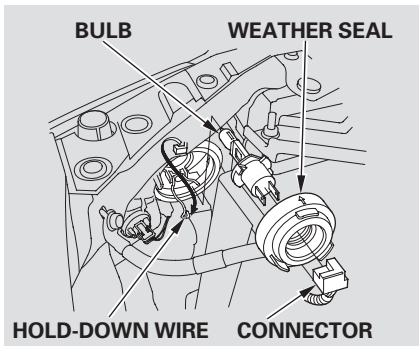

2. Remove the electrical connector from the bulb by pulling the connector straight back.
3. Remove the rubber weather seal by pulling on the tab.
4. Unclip the end of the hold-down wire from its slot. Pivot it out of the way and remove the bulb.
5. Insert the new bulb into the hole, making sure the tabs are in their slots. Pivot the hold-down wire back in place, and clip the end into the slot.
6. Install the rubber seal over the back of the headlight assembly. Make sure it is right side up; it is marked with an arrow.

*CONTINUED*

# Lights

---

7. Push the electrical connector onto the new bulb. Make sure it is connected securely.

Turn on the headlights to test the new bulb.

8. On the driver's side, reinstall the air intake cover. Reinstall the three fasteners and secure them by pushing on the heads until they lock.

## Replacing a Front Turn Signal Light Bulb

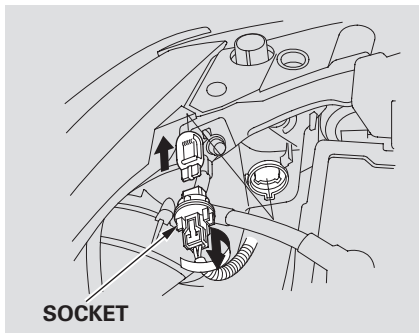

1. Open the hood.
2. Remove the socket from the headlight assembly by turning it one-quarter turn counterclockwise.

3. Pull the bulb straight out of its socket.  
Push the new bulb straight into the socket until it bottoms.
4. Insert the socket back into the headlight assembly. Turn it clockwise to lock it in place.
5. Turn on the lights to make sure the new bulb is working.

## Replacing a Front Parking Light Bulb

1. If you are changing the bulb on the driver's side, start the engine, turn the steering wheel all the way to the right, and turn off the engine. If you are changing the bulb on the passenger's side, turn the steering wheel to the left.

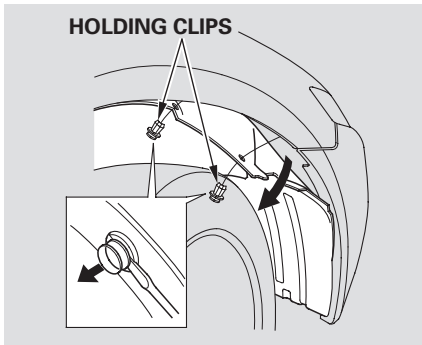

2. Use a flat-tipped screwdriver to remove the two holding clips from the inner fender.
3. Pull the inner fender cover back.
4. Remove the socket from the headlight assembly by turning it one-quarter turn counterclockwise.

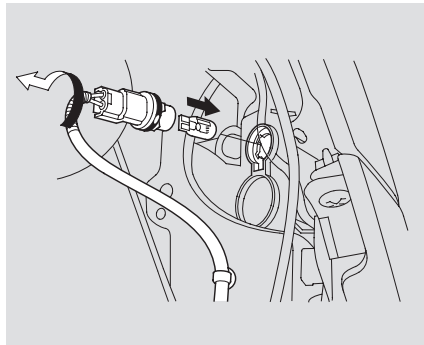

5. Pull the bulb straight out of its socket. Push the new bulb straight into the socket until it bottoms.

*CONTINUED*



# Lights

6. Insert the socket back into the headlight assembly. Turn it clockwise to lock it in place.
7. Turn on the parking lights to make sure the new bulb works.
8. Put the inner fender cover in place. Install the holding clips. Lock each one in place by pushing on the center.

## Replacing Rear Bulbs (in Fenders)

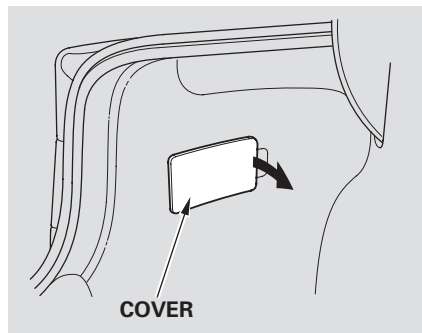

1. Open the trunk.

Remove the light assembly cover by pulling its outside edge.

2. Determine which of the three bulbs is burned out: brake/taillight turn signal light or side marker light.

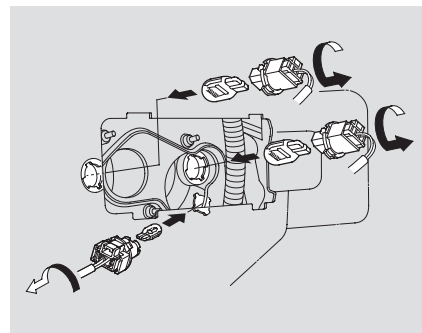

3. Remove the socket for that bulb by turning it one-quarter turn counterclockwise.
4. Pull the bulb straight out of its socket. Push the new bulb straight into the socket until it bottoms.

5. Reinstall the socket into the light assembly by turning it clockwise until it locks.
6. Turn on the lights to make sure the new bulb is working.
7. Install the light assembly cover. Make sure it snaps into place.

## Replacing Rear Bulbs (in Trunk Lid)

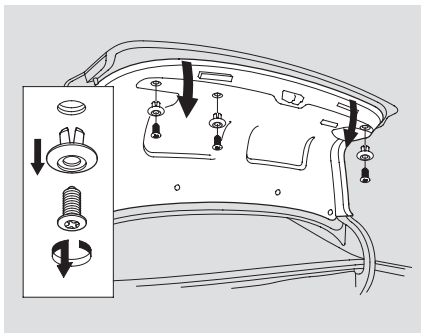

1. Open the trunk.
2. To replace a bulb on the left side, remove the screws in the center of each of the two fasteners. On the right side, remove the screw of the fastener.
3. Pull the lining back carefully.

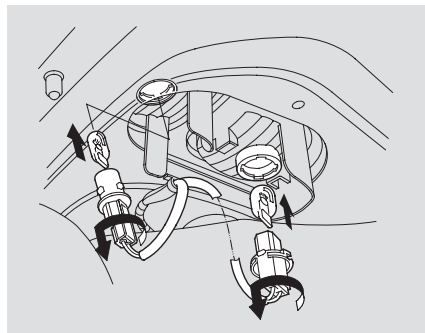

4. Determine which of the two bulbs is burned out: taillight or back-up light.

*CONTINUED*

## Lights

---

5. Remove the socket by turning it one-quarter turn counterclockwise.
6. Pull the bulb straight out of its socket. Push the new bulb in until it bottoms in the socket.
7. Insert the socket back into the light assembly. Turn it clockwise to lock it in place.
8. Turn on the lights to make sure the new bulb is working.
9. Reinstall the trunk lid trim. Make sure it is installed under the edge of the trunk lid seal.
10. Put each trim clip in the hole on the trunk lid trim and push on the center until it locks (the center is flush with the head).

### **Side Turn Signal Light**

Each outside mirror has side turn signal lights. The lights should be replaced by your Acura dealer.

## Replacing a High-mount Brake Light Bulb

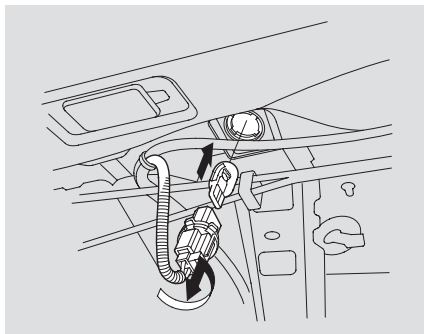

1. Open the trunk and remove the socket from the light assembly by turning it one-quarter turn counter-clockwise.
2. Remove the burned-out bulb by pulling it straight out of the socket.
3. Install the new bulb and reinstall the socket. Make sure the new bulb is working.

## Rear License Plate Bulb

The license plate has two lights above it. The bulbs should be replaced by your Acura dealer.

# Lights

## Replacing Bulbs in the Interior Lights

The ceiling light, door lights and vanity mirror lights come apart the same way, but they do not use the same type of bulb.

1. Remove the lens by carefully prying on the edge of the lens with a fingernail file or a small flat-tip screwdriver. Do not pry on the edge of the housing around the lens.

Door light:

Pry on the top left or right of the lens.

Ceiling light:

Pry on the front edge of the lens near both sides.

Spotlights:

Pry on the inner edge of both spotlights.

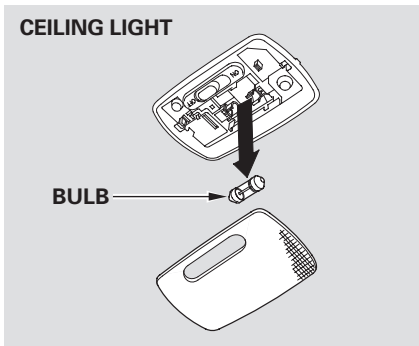

2. Remove the bulb by pulling it straight out of its metal tabs.
3. Push the new bulb into the metal tabs. Carefully snap the lens back in place.

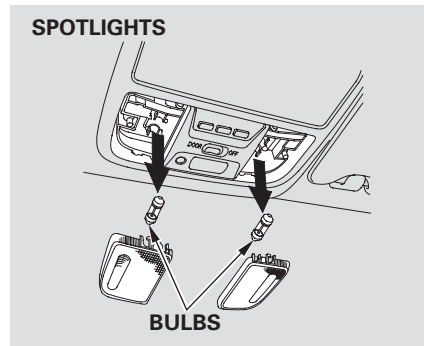

## DOOR COURTESY LIGHT

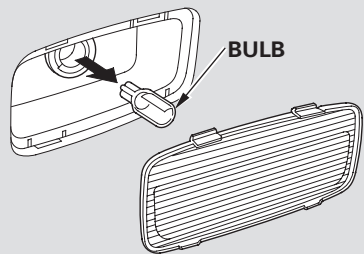

## VANITY MIRROR LIGHT

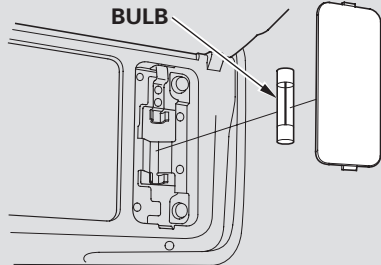

# Lights

---

## Replacing the Trunk Light Bulb

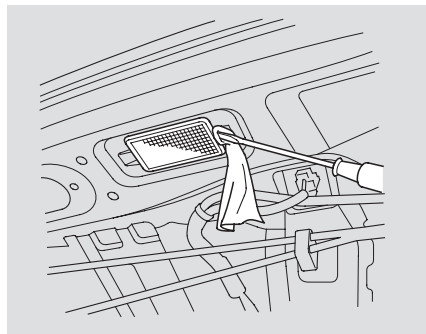

### 1. Open the trunk.

Put a cloth on the right side edge of the trunk light assembly. Remove the trunk light assembly by using a small flat-tipped screwdriver to pry carefully on the right edge of the assembly.

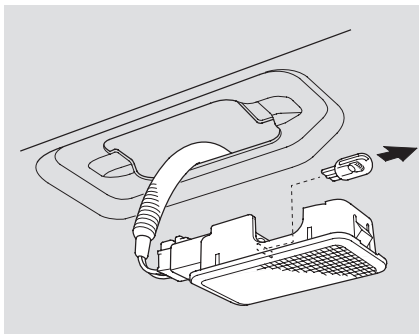

### 2. Pull the bulb straight out of the holder. Push the new bulb straight into the holder until it bottoms.

### 3. Put the light assembly back into the hole, left side first. Push on the right side until it snaps into place.

If you need to park your car for an extended period (more than one month), there are several things you should do to prepare it for storage. Proper preparation helps prevent deterioration and makes it easier to get your car back on the road. If possible, store your car indoors.

- Fill the fuel tank.
- Change the engine oil and filter (see page [246](#)).
- Wash and dry the exterior completely.
- Clean the interior. Make sure the carpeting, floor mats, etc. are completely dry.
- Leave the parking brake off. Put the transmission in Reverse (manual) or Park (automatic).

- Block the rear wheels.
- If the car is to be stored for a longer period, it should be supported on jackstands so the tires are off the ground.
- Leave one window open slightly (if the car is being stored indoors).
- Disconnect the battery.
- Support the front wiper blade arms with a folded towel or rag so they do not touch the windshield.
- To minimize sticking, apply a silicone spray lubricant to all door and trunk seals. Also, apply a car body wax to the painted surfaces that mate with the door and trunk seals.

- Cover the car with a “breathable” cover, one made from a porous material such as cotton. Nonporous materials, such as plastic sheeting, trap moisture, which can damage the paint.
- If possible, run the engine for a while periodically (preferably once a month).

If you store your car for 12 months or longer, have your Acura dealer perform the inspections called for in the 24 months maintenance schedule (Normal Conditions) as soon as you take it out of storage (see page [234](#)). The replacements called for in the maintenance schedule are not needed unless the car has actually reached that time or mileage.





Regular cleaning and polishing of your Acura helps to keep it “new” looking. This section gives you hints on how to clean your car and preserve its appearance: the paint, brightwork, wheels and interior. Also included are several things you can do to help prevent corrosion.

Exterior Care.....	296
Washing .....	296
Waxing .....	297
Aluminum Wheels .....	297
Paint Touch-up.....	297
Interior Care .....	298
Carpeting .....	298
Floor Mats .....	298
Fabric .....	299
Vinyl .....	299
Leather.....	299
Seat Belts.....	299
Windows .....	300
Air Fresheners.....	300
Corrosion Protection .....	311
Body Repairs .....	312

## Exterior Care

---

### Washing

Frequent washing helps preserve your car's beauty. Dirt and grit can scratch the paint, while tree sap and bird droppings can permanently ruin the finish.

Wash your car in a shady area, not in direct sunlight. If the car is parked in the sun, move it into the shade and let the exterior cool down before you start.

Only use the solvents and cleaners recommended in this Owner's Manual.

#### NOTICE

*Chemical solvents and strong cleaners can damage the paint, metal, and plastic on your car.*

- Rinse the car thoroughly with cool water to remove loose dirt.
  - Fill a bucket with cool water. Mix in a mild detergent, such as dishwashing liquid or a product made especially for car washing.
  - Wash the car using the water and detergent solution and a soft-bristle brush, sponge, or soft cloth. Start at the top and work your way down. Rinse frequently.
  - Check the body for road tar, tree sap, etc. Remove these stains with tar remover or turpentine. Rinse it off immediately so it does not harm the finish. Remember to re-wax these areas, even if the rest of the car does not need waxing.
- When you have washed and rinsed the whole exterior, dry it with a chamois or soft towel. Letting it air-dry will cause dulling and water spots.

As you dry the car, inspect it for chips and scratches that could allow corrosion to start. Repair them with touch-up paint (see page [297](#)).

### **Waxing**

Always wash and dry the whole car before waxing it. You should wax your car, including the metal trim, whenever water sits on the surface in large patches. It should form into beads or droplets after waxing.

You should use a quality liquid or paste wax. Apply it according to the instructions on the container. In general, there are two types of products:

**Waxes** — A wax coats the finish and protects it from damage by exposure to sunlight, air pollution, etc. You should use a wax on your Acura when it is new.

**Polishes** — Polishes and cleaner/waxes can restore the shine to paint that has oxidized and lost some of its shine. They normally contain mild abrasives and solvents that remove the top layer of the finish. You

should use a polish on your Acura if the finish does not have its original shine after using a wax.

Cleaning tar, insects, etc. with removers also takes off the wax. Remember to re-wax those areas, even if the rest of the car does not need waxing.

### **Aluminum Wheels**

Clean your Acura's aluminum alloy wheels as you do the rest of the exterior. Wash them with the same solution, and rinse them thoroughly.

The wheels have a protective clear-coat that keeps the aluminum from corroding and tarnishing. Using harsh chemicals, including some commercial wheel cleaners or stiff brushes, can damage this clear-coat. Only use a mild detergent and soft brush or sponge to clean the wheels.

### **Paint Touch-up**

Your dealer has touch-up paint to match your car's color. The color code is printed on a sticker on the driver's doorjamb. Take this code to your dealer so you are sure to get the correct color.

Inspect your car frequently for chips or scratches in the paint. Repair them right away to prevent corrosion of the metal underneath. Use the touch-up paint only on small chips and scratches. More extensive paint damage should be repaired by a professional.

## Interior Care

---

### **Carpeting**

Vacuum the carpeting frequently to remove dirt. Ground-in dirt will make the carpet wear out faster.

Periodically shampoo the carpet to keep it looking new. Use one of the foam-type carpet cleaners on the market. Follow the instructions that come with the cleaner, applying it with a sponge or soft brush. Keep the carpeting as dry as possible by not adding water to the foam.

### **Floor Mats**

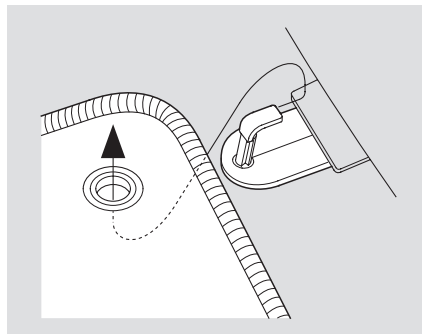

The Acura driver's floor mat that came with your car was designed to be hooked over the floor mat anchor. This keeps the floor mat from sliding forward and possibly interfering with the pedals.

If you remove the driver's floor mat, make sure to re-anchor it when you put it back in your car.

If you replace it, use an Acura floor mat that is designed to be used with the floor mat anchor in your car.

If you use a non-Acura floor mat in the driver's footwell, make sure it fits properly and that it can be used with the floor mat anchors.

Do not put additional floor mats on top of the anchored mat, otherwise the additional mats may slide forward and interfere with the pedals.

### Fabric

Vacuum dirt and dust out of the material frequently. For general cleaning, use a solution of mild soap and lukewarm water, letting it air dry. To clean off stubborn spots, use a commercially-available fabric cleaner. Test it on a hidden area of the fabric first, to make sure it does not bleach or stain the fabric. Follow the instructions that come with the cleaner.

### Vinyl

Remove dirt and dust with a vacuum cleaner. Wipe the vinyl with a soft cloth dampened in a solution of mild soap and water. Use the same solution with a soft-bristle brush on more difficult spots. You can also use commercially-available spray or foam-type vinyl cleaners.

### Leather

Vacuum dirt and dust from the leather frequently. Pay particular attention to the pleats and seams. Clean the leather with a soft cloth dampened with clear water, then buff it with a clean, dry cloth. If further cleaning is needed, use a soap specifically for leather, such as saddle soap. Apply this soap with a damp, soft cloth. Wipe down and buff as described above.

### Seat Belts

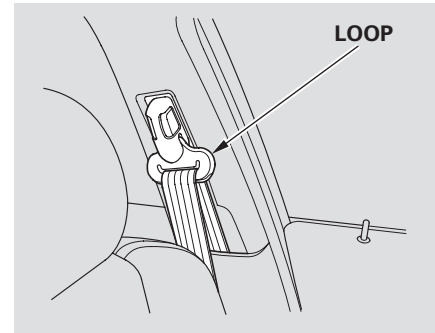

If your seat belts get dirty, you can use a soft brush with a mixture of mild soap and warm water to clean them. Do not use bleach, dye, or cleaning solvents. They can weaken the belt material. Let the belts air-dry before you use the car.

*CONTINUED*

## Interior Care

---

Dirt build-up in the loops of the seat belt anchors can cause the belts to retract slowly. Wipe the insides of the loops with a clean cloth dampened in mild soap and warm water or isopropyl alcohol.

### Windows

Clean the windows, inside and out, with a commercially-available glass cleaner. You can also use a mixture of one part white vinegar to ten parts water. This will remove the haze that builds up on the inside of the windows. Use a soft cloth or paper towels to clean all glass and clear plastic surfaces.

#### NOTICE

*The rear window defogger and antenna wires are bonded to the inside of the glass. Wiping vigorously up-and-down can dislodge and break these wires. When cleaning the rear window, use gentle pressure and wipe side-to-side.*

### Air Fresheners

If you want to use an air freshener/deodorizer in the interior of your car, it is best to use a solid type. Some liquid air fresheners contain chemicals that may cause parts of the interior trim and fabric to crack or discolor.

If you use a liquid air freshener, make sure you fasten it securely so it does not spill as you drive.

Two factors normally contribute to causing corrosion in your car:

1. Moisture trapped in body cavities. Dirt and road salt that collects in hollows on the underside of the car stays damp, promoting corrosion in that area.
2. Removal of paint and protective coatings from the exterior and underside of the car.

Many corrosion-preventive measures are built into your Acura. You can help keep your car from corroding by performing some simple periodic maintenance:

- Repair chips and scratches in the paint as soon as you discover them.
  - Inspect and clean out the drain holes in the bottom of the doors and body.
  - Check the floor coverings for dampness. Carpeting and floor mats may remain damp for a long time, especially in winter. This dampness can eventually cause the floor panels to corrode.
- Use a high-pressure spray to clean the underside of your car. This is especially important in areas that use road salt in winter. It is also a good idea in humid climates and areas subject to salt air. Be careful not to damage the ABS wheel sensors and wiring at each wheel.
  - Have the corrosion-preventive coatings on the underside of your car inspected and repaired periodically.



## Body Repairs

---

Body repairs can affect your car's resistance to corrosion. If your car needs repairs after a collision, pay close attention to the parts used in the repair and the quality of the work.

Make sure the repair facility uses Acura replacement body parts. Some companies make sheet metal pieces that seem to duplicate the original Acura body parts, but are actually inferior in fit, finish, and corrosion resistance. Once installed, they do not give the same high-quality appearance.

When reporting your collision to the insurance company, tell them you want Acura parts used in the repair. Although most insurers recognize the quality of original parts, some may try to specify that the repairs be done with other available parts. You should investigate this before any repairs have begun.

Take your car to your authorized Acura dealer for inspection after the repairs are completed. Your dealer can make sure that quality materials were used, and that corrosion-preventive coatings were applied to all repaired and replaced parts.

This section covers the more-common problems that motorists experience with their cars. It gives you information about how to safely evaluate the problem and what to do to correct it. If the problem has stranded you on the side of the road, you may be able to get going again. If not, you will also find instructions on getting your car towed.

Compact Spare Tire.....	304
Changing a Flat Tire .....	305
If Your Engine Won't Start.....	310
Nothing Happens or the Starter Motor Operates Very Slowly.....	310
The Starter Operates Normally .....	311
Jump Starting .....	312
If Your Engine Overheats.....	315
Low Oil Pressure Indicator .....	317
Charging System Indicator.....	318
Malfunction Indicator Lamp .....	319
Readiness Codes.....	320
Brake System Indicator .....	321
Closing the Moonroof .....	322
Fuses .....	323
Checking and Replacing .....	324
Emergency Towing .....	328

## Compact Spare Tire

Your car has a compact spare tire that takes up less space. Use this spare tire as a temporary replacement only. Get your regular tire repaired or replaced and put it back on your car as soon as you can.

Check the inflation pressure of the compact spare tire every time you check the other tires. It should be inflated to:  
60 psi (420 kPa , 4.2 kgf/cm<sup>2</sup>)

Follow these precautions whenever you are using the compact spare tire:

- Do not exceed 50 mph (80 km/h) under any circumstances.

- This tire gives a harsher ride and less traction on some road surfaces than the regular tire. Use greater caution while driving on this tire.
- Do not mount snow chains on the compact spare.
- The wheel of the compact spare tire is designed especially to fit your car. Do not use your spare tire on another car unless it is the same make and model.
- Turn off the VSA system (see page 218 ). Driving with the compact spare tire may activate the VSA system.

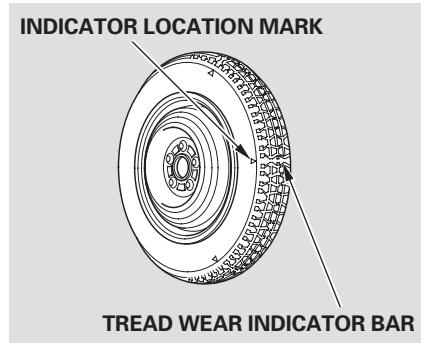

The compact spare tire has a shorter tread life than a regular tire. Replace it when you can see the tread wear indicator bars. The replacement should be the same size and design tire, mounted on the same wheel. The compact spare tire is not designed to be mounted on a regular wheel, and the compact wheel is not designed for mounting a regular tire.

## Changing a Flat Tire

If you have a flat tire while driving, stop in a safe place to change it. Stopping in traffic or on the shoulder of a busy road is dangerous. Drive slowly along the shoulder until you get to an exit or an area to stop that is far away from the traffic lanes.

### **⚠ WARNING**

The car can easily roll off the jack, seriously injuring anyone underneath.

Follow the directions for changing a tire exactly, and never get under the car when it is supported only by the jack.

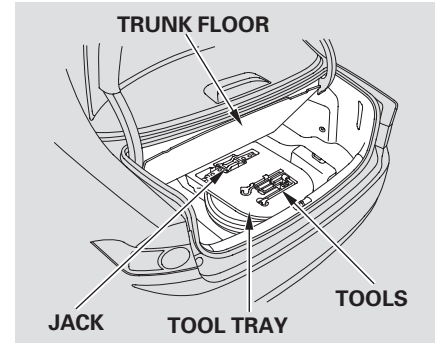

1. Park the car on firm, level and non-slippery ground away from traffic. Put the transmission in Park (automatic) or Reverse (manual). Apply the parking brake.
2. Turn on the hazard warning lights, and turn the ignition switch to LOCK (0). Have all the passengers get out of the car while you change the tire.

*CONTINUED*

## Changing a Flat Tire

---

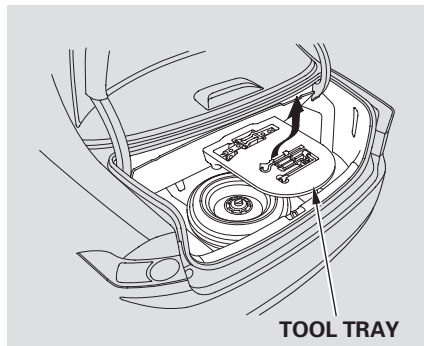

3. Open the trunk. Raise the trunk floor by lifting up on the back edge.
4. Take the tool tray out of the trunk, and remove the tools and the jack.

5. Unscrew the wing bolt and take the spare tire out of the trunk.

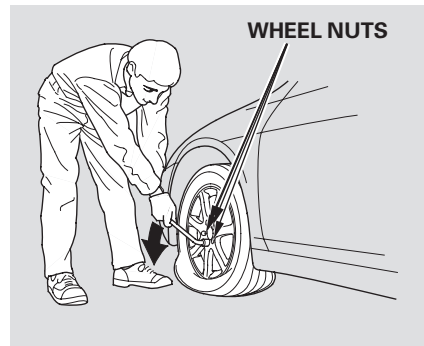

6. Loosen the five wheel nuts 1/2 turn with the wheel wrench.

## Changing a Flat Tire

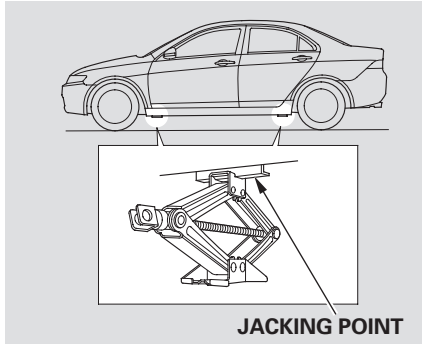

7. Locate the jacking point nearest the tire you need to change. Place the jack under the jacking point. Turn the end bracket clockwise until the top of the jack contacts the jacking point. Make sure the jacking point tab is resting in the jack notch.

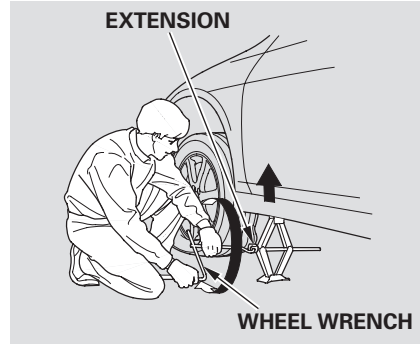

8. Use the extension and wheel wrench as shown to raise the car until the flat tire is off the ground.

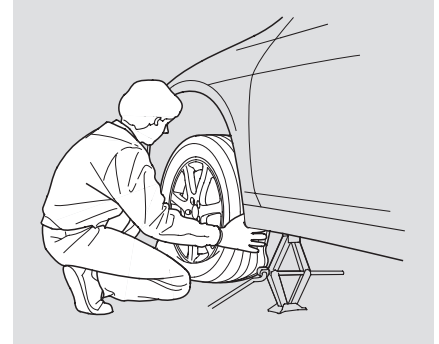

9. Remove the wheel nuts and flat tire. Temporarily place the flat tire on the ground with the outside surface of the wheel facing up. You could scratch the wheel if you put it face down.

*CONTINUED*

## Changing a Flat Tire

---

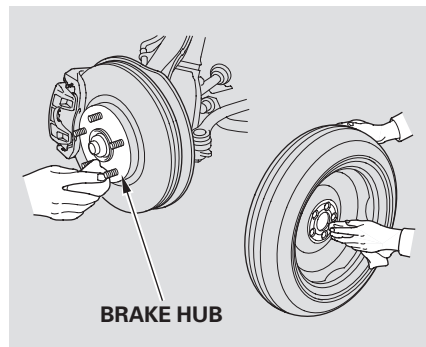

10. Before mounting the spare tire, wipe any dirt off the mounting surface of the wheel and hub with a clean cloth. Wipe the hub carefully, it may be hot from driving.

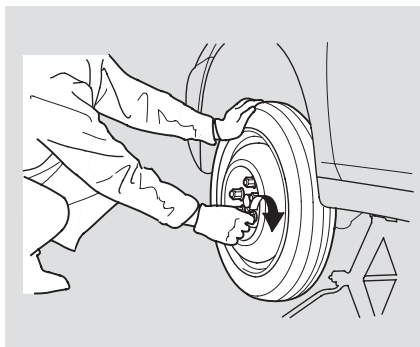

11. Put on the spare tire. Put the wheel nuts back on finger-tight, then tighten them in a crisscross pattern with the wheel wrench until the wheel is firmly against the hub. Do not try to tighten them fully.

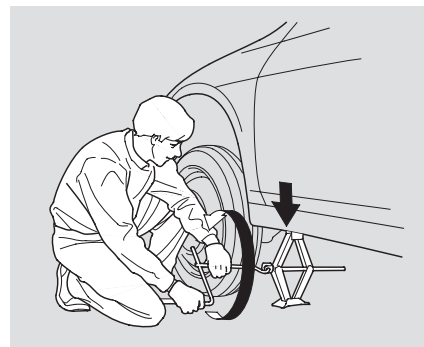

12. Lower the car to the ground and remove the jack.

## Changing a Flat Tire

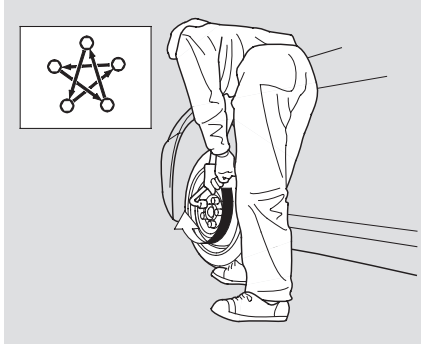

13. Tighten the wheel nuts securely in the same crisscross pattern. Have the wheel nut torque checked at the nearest automotive service facility.  
Tighten the wheel nuts to:  
80 lbf-ft (108 N·m , 11 kgf·m)

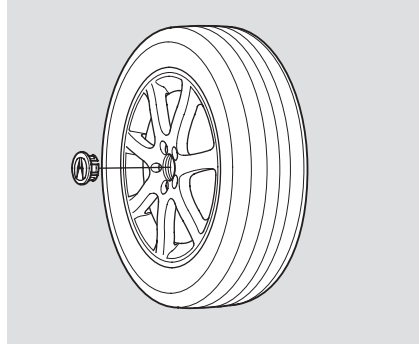

14. Remove the center cap before storing the flat tire in the trunk well.

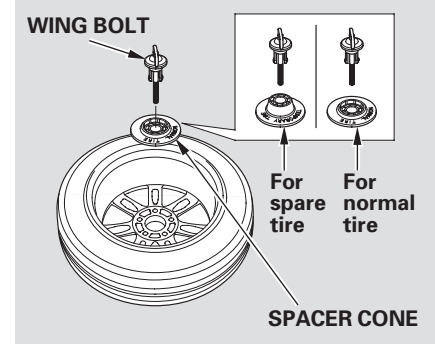

15. Place the flat tire face down in the spare tire well.
16. Remove the spacer cone from the wing bolt, turn it over, and put it back on the bolt.
17. Secure the flat tire by screwing the wing bolt back into its hole.

*CONTINUED*



## Changing a Flat Tire, If Your Engine Won't Start

---

18. Store the tools and the jack in the tool tray, and place the tool tray back in the trunk.

### **⚠ WARNING**

Loose items can fly around the interior in a crash and could seriously injure the occupants.

Store the wheel, jack, and tools securely before driving.

19. Store the wheel cover or center cap in the trunk. Make sure it does not get scratched or damaged. Lower the trunk floor, then close the trunk lid.

### **If Your Engine Won't Start**

Diagnosing why your engine won't start falls into two areas, depending on what you hear when you turn the key to START (III):

- You hear nothing, or almost nothing. The engine's starter motor does not operate at all, or operates very slowly.
- You can hear the starter motor operating normally, or the starter motor sounds like it is spinning faster than normal, but the engine does not start up and run.

### **Nothing Happens or the Starter Motor Operates Very Slowly**

When you turn the ignition switch to START (III), you do not hear the normal noise of the engine trying to start. You may hear a clicking sound or series of clicks, or nothing at all. Check these things:

- Check the transmission interlock. If you have a manual transmission, the clutch pedal must be pushed all the way to the floor or the starter will not operate. With an automatic transmission, it must be in Park or Neutral.
- Turn the ignition switch to ON (II). Turn on the headlights and check their brightness. If the headlights are very dim or don't light at all, the battery is discharged. See **Jump Starting** on page [312](#).

- Turn the ignition switch to START (III). If the headlights do not dim, check the condition of the fuses. If the fuses are OK, there is probably something wrong with the electrical circuit for the ignition switch or starter motor. You will need a qualified technician to determine the problem. (See **Emergency Towing** on page 328.)

If the headlights dim noticeably or go out when you try to start the engine, either the battery is discharged or the connections are corroded. Check the condition of the battery and terminal connections (see page 265). You can then try jump starting the car from a booster battery (see page 312).

### The Starter Operates Normally

In this case, the starter motor's speed sounds normal, or even faster than normal, when you turn the ignition switch to START (III), but the engine does not run.

- Are you using the proper starting procedure? Refer to **Starting the Engine** on page 199.
- Your car has the Immobilizer System. You should use a properly-coded master or valet key to start the engine (see page 79). A key that is not properly coded will cause the immobilizer system indicator in the dash panel to blink rapidly.

- Do you have fuel? Turn the ignition switch to ON (II) for a minute and watch the fuel gauge. The low fuel level warning light may not be working, so you were not reminded to fill the tank.
- There may be an electrical problem, such as no power to the fuel pump. Check all the fuses (see page 324).

If you find nothing wrong, you will need a qualified technician to find the problem. See **Emergency Towing** on page 328.

## Jump Starting

---

If your car's battery has run down, you may be able to start the engine by using a booster battery. Although this seems like a simple procedure, you should take several precautions.

### **WARNING**

A battery can explode if you do not follow the correct procedure, seriously injuring anyone nearby.

Keep all sparks, open flames, and smoking materials away from the battery.

You cannot start an Acura with an automatic transmission by pushing or pulling it.

To jump start your car, follow these directions closely:

1. Open the hood and check the physical condition of the battery (see page 265). In very cold weather, check the condition of the electrolyte. If it seems slushy or like ice, do not try jump starting until it thaws.

### **NOTICE**

*If a battery sits in extreme cold, the electrolyte inside can freeze. Attempting to jump start with a frozen battery can cause it to rupture.*

2. Turn off all the electrical accessories: climate control, audio system, lights, etc.  
Put the transmission in Neutral or Park, and set the parking brake.

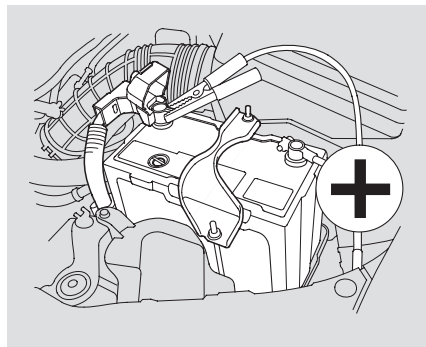

3. Connect one jumper cable to the positive (+) terminal on your Acura's battery. Connect the other end to the positive (+) terminal on the booster battery.

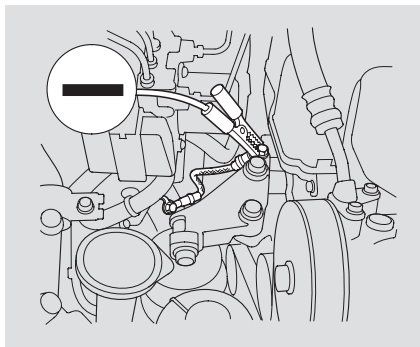

4. Connect the second jumper cable to the negative (-) terminal on the booster battery. Connect the other end to the grounding strap as shown. Do not connect this jumper cable to any other part of the engine.

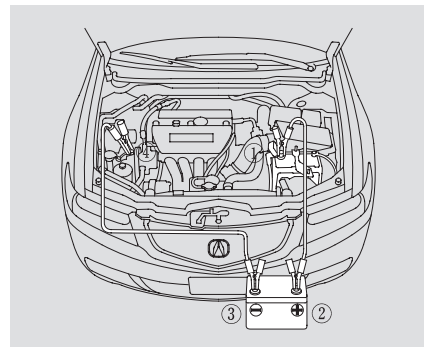

The numbers in the illustrations show you the order to connect the jumper cables.

5. If the booster battery is in another vehicle, have an assistant start that vehicle and run it at a fast idle.

*CONTINUED*

## Jump Starting

---

6. Start your car. If the starter motor still operates slowly, check the jumper cable connections to make sure they have good metal-to-metal contact.
7. Once your car is running, disconnect the negative cable from your car, then from the booster battery. Disconnect the positive cable from your car, then the booster battery.

Keep the ends of the jumper cables away from each other and any metal on the car until all are disconnected. Otherwise, you may cause an electrical short.

The pointer of your car's temperature gauge should stay in the mid-range under most conditions. It may go higher if you are driving up a long steep hill on a very hot day. If it climbs to the red mark, you should determine the reason.

### NOTICE

*Driving with the temperature gauge pointer at the red mark can cause serious damage to your engine.*

Your car can overheat for several reasons, such as lack of coolant or a mechanical problem. The only indication may be the temperature gauge climbing to or above the red mark. Or you may see steam or spray coming from under the hood. In either case, you should take immediate action.

### WARNING

Steam and spray from an overheated engine can seriously scald you.

Do not open the hood if steam is coming out.

1. Safely pull to the side of the road. Put the transmission in Neutral or Park and set the parking brake. Turn off the climate control and all other accessories. Turn on the hazard warning indicators.
2. If you see steam and/or spray coming from under the hood, turn off the engine.
3. If you do not see steam or spray, leave the engine running and watch the temperature gauge. If the high heat is due to overloading (climbing a long, steep hill on a hot day with the A/C running, for example), the engine should start to cool down almost immediately. If it does, wait until the temperature gauge comes down to the mid-point, then continue driving.

*CONTINUED*

## If Your Engine Overheats

---

4. If the temperature gauge stays at the red mark, turn off the engine.
5. Wait until you see no more signs of steam or spray, then open the hood.
6. Look for any obvious coolant leaks, such as a split radiator hose. Everything is still extremely hot, so use caution. If you find a leak, it must be repaired before you continue driving (see **Emergency Towing** on page 328 ).
7. If you don't find an obvious leak, check the coolant level in the radiator reserve tank (see page 189 ). If the level is below the MIN mark, add coolant to halfway between the MIN and MAX marks.
8. If there was no coolant in the reserve tank, you may also have to add coolant to the radiator. Let the engine cool down until the pointer

reaches the middle of the temperature gauge, or lower, before checking the radiator.

### **WARNING**

Removing the radiator cap while the engine is hot can cause the coolant to spray out, seriously scalding you.

Always let the engine and radiator cool down before removing the radiator cap.

9. Using gloves or a large heavy cloth, turn the radiator cap counterclockwise, without pushing down, to the first stop. This releases any remaining pressure in the cooling system. After the pressure releases, push down on the cap and turn it until it comes off.

10. Start the engine and set the temperature control to its upper limit, . Add coolant to the radiator up to the base of the filler neck. If you do not have the proper coolant mixture available, you can add plain water. Remember to have the cooling system drained and refilled with the proper mixture as soon as you can.
11. Put the radiator cap back on tightly. Run the engine and watch the temperature gauge. If it goes back to the red mark, the engine needs repair. (See **Emergency Towing** on page 328 .)
12. If the temperature stays normal, check the coolant level in the radiator reserve tank. If it has gone down, add coolant to the MAX mark. Put the cap back on tightly.

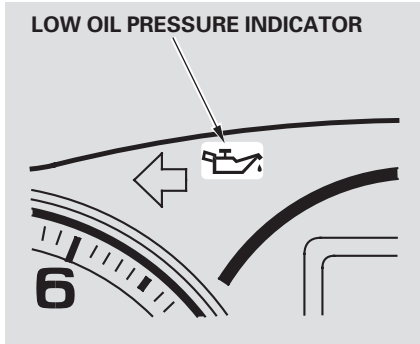

This indicator should light when the ignition switch is ON (II), and go out after the engine starts. It should never come on when the engine is running. If it starts flashing, it indicates that the oil pressure dropped very low for a moment, then recovered. If the indicator stays on with the engine running, it shows that the engine has lost oil pressure and serious engine damage is possible. In either case, you should take immediate action.

### NOTICE

*Running the engine with low oil pressure can cause serious mechanical damage almost immediately. Turn off the engine as soon as you can safely get the car stopped.*

1. Safely pull off the road and shut off the engine. Turn on the hazard warning indicators.
2. Let the car sit for a minute. Open the hood and check the oil level (see page 187). Although oil level and oil pressure are not directly connected, an engine that is very low on oil can lose pressure during cornering and other driving maneuvers.
3. If necessary, add oil to bring the level back to the full mark on the dipstick (see page 244).

4. Start the engine and watch the oil pressure indicator. If the light does not go out within ten seconds, turn off the engine. There is a mechanical problem that needs to be repaired before you can continue driving. (See **Emergency Towing** on page 328.)



## Charging System Indicator

---

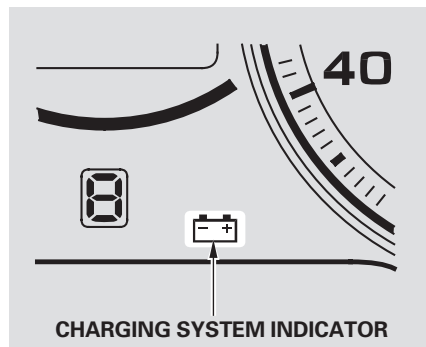

This indicator should come on when the ignition switch is ON (II), and go out after the engine starts. If it comes on brightly when the engine is running, it indicates that the charging system has stopped charging the battery.

Immediately turn off all electrical accessories: radio, climate control, rear defogger, cruise control, etc. Try not to use other electrically-operated controls such as the power windows. Keep the engine running and take extra care not to stall it. Starting the engine will discharge the battery rapidly.

By eliminating as much of the electrical load as possible, you can drive several miles (kilometers) before the battery is too discharged to keep the engine running. Drive to a service station or garage where you can get technical assistance.

## Malfunction Indicator Lamp

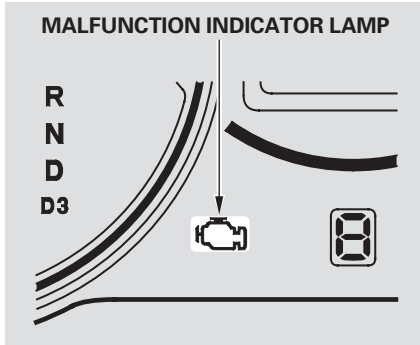

This indicator should light when the ignition switch is ON (II), and go out after the engine starts. If it comes on at any other time, it indicates one of the engine's emissions control systems may have a problem. Even though you may feel no difference in your car's performance, it can reduce your fuel economy and cause your car to put out excessive emissions. Continued operation may cause serious damage.

If you have recently refueled your car, the cause of this indicator coming on could be a loose or missing fuel fill cap. Check the cap and tighten it until it clicks at least three times. Replace the fuel fill cap if it is missing. Tightening the cap will not make the indicator turn off immediately; it takes at least three days of normal driving.

If the indicator remains on past three days of normal driving, or the fuel cap was not loose or missing, have the car checked by the dealer as soon as possible. Drive moderately until the dealer has inspected the problem. Avoid full-throttle acceleration and driving at high speed.

You should also have the dealer inspect your car if this indicator comes on repeatedly, even though it may turn off as you continue driving.

### NOTICE

*If you keep driving with the malfunction indicator lamp on, you can damage your car's emissions controls and engine. Those repairs may not be covered by your car's warranties.*

This indicator may also come on along with the "D" indicator.

## Malfunction Indicator Lamp

---

### Readiness Codes

Your car has certain “readiness codes” that are part of the on-board diagnostics for the emissions systems. In some states, part of the emissions testing is to make sure these codes are set. If they are not set, the test cannot be completed.

If your car’s battery has been disconnected or gone dead, these codes are erased. It takes several days of driving under various conditions to set the codes again.

If possible, do not take your car for a state emissions test until the readiness codes are set. Refer to State Emissions Testing for more information. (See page [345](#).)

To check if they are set, turn the ignition ON (II), but do not start the engine. The Malfunction Indicator Lamp will come on for 20 seconds. If it then goes off, the readiness codes are set. If it blinks 5 times, the readiness codes are not set.

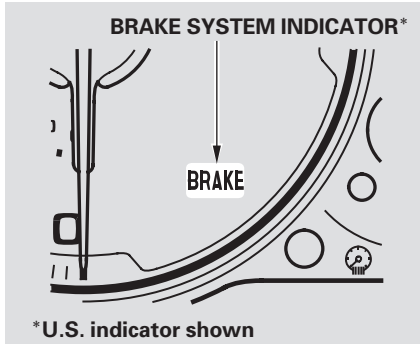

The Brake System Indicator normally comes on when you turn the ignition switch ON (II). It is a reminder to check the parking brake. It comes on and stays lit if you do not fully release the parking brake.

If it comes on at any other time, it indicates a problem with the car's brake system. In most cases, the problem is a low fluid level in the brake fluid reservoir. Press lightly on the brake pedal to see if it feels normal. If it does, check the brake fluid level the next time you stop at a service station (see page 259). If the fluid level is low, take the car to your dealer and have the brake system inspected for leaks or worn brake pads.

However, if the brake pedal does not feel normal, you should take immediate action. Because of the brake system's dual-circuit design, a problem in one part of the system will still give you braking at two wheels. You will feel the brake pedal go down much farther before the car begins to slow down, and you will have to press harder on the pedal. The distance needed to stop will be much longer.

Slow down by shifting to a lower gear, and pull to the side of the road when it is safe. Because of the longer distance needed to stop, it is hazardous to drive the car. You should have it towed, and repaired as soon as possible. (See **Emergency Towing** on page 328.)

If you must drive the car a short distance in this condition, drive slowly and cautiously.

If the ABS indicator comes on with this indicator, have the car inspected by your Acura dealer immediately.

## Closing the Moonroof

If the electric motor will not close the moonroof, do the following:

1. Check the fuse for the moonroof motor (see page 327). If the fuse is blown, replace it with one of the same or lower rating.
2. Try closing the moonroof. If the new fuse blows immediately or the moonroof motor still does not operate, you can close the moonroof manually.
3. Get the moonroof wrench out of the tool kit in the trunk.

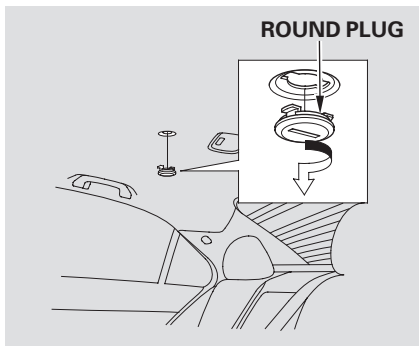

4. Use a screwdriver or coin to remove the round plug in the center of the headliner.

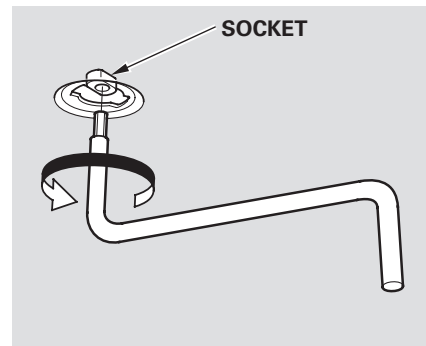

5. Insert the moonroof wrench into the socket behind this plug. Turn the wrench until the moonroof is fully closed.
6. Remove the wrench. Reinstall the round plug.

If you need to close the moonroof manually, it means your car's moonroof opening/closing function is developing a problem. Have your car checked by an Acura dealer.

All the electrical circuits in your car have fuses to protect them from a short circuit or overload. These fuses are located in two fuse boxes.

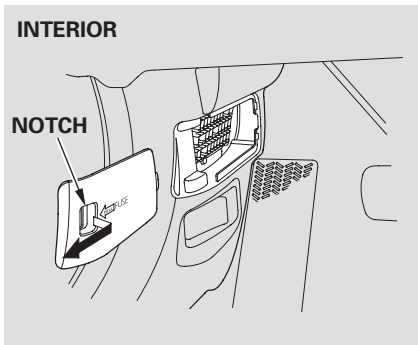

The interior fuse box is on the driver's lower left side. To remove the fuse box lid, put your finger in the notch on the lid, and pull it toward you and take it out of its hinges.

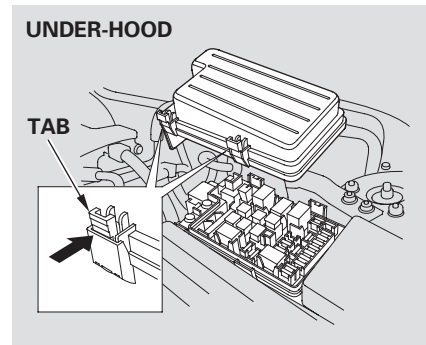

The under-hood fuse box is located near the back of the engine compartment on the driver's side. To open it, push the tabs as shown.

# Fuses

## Checking and Replacing Fuses

If something electrical in your car stops working, the first thing you should check for is a blown fuse. Determine from the chart on pages [326](#) and [327](#), or the diagram on the fuse box lid, which fuse or fuses control that component. Check those fuses first, but check all the fuses before deciding that a blown fuse is not the cause. Replace any blown fuses and check the component's operation.

1. Turn the ignition switch to LOCK (0). Make sure the headlights and all other accessories are off.
2. Remove the cover from the fuse box.

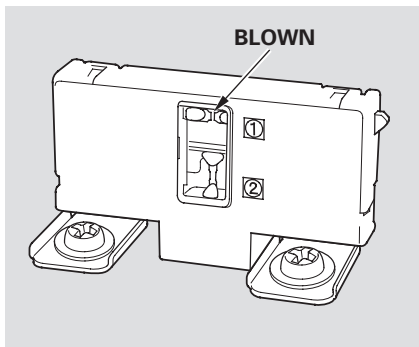

3. Check each of the large fuses in the under-hood fuse box by looking at the wire inside. Removing these fuses requires a Phillips-head screwdriver.

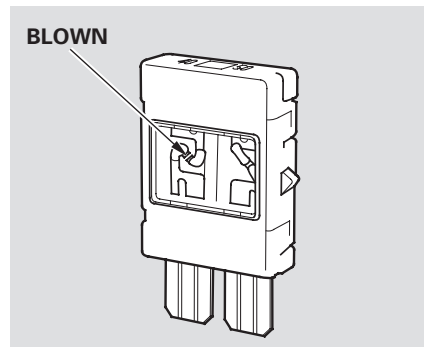

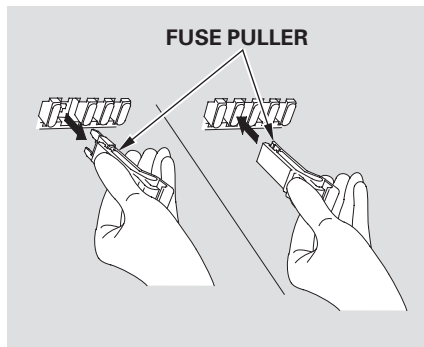

4. Check the smaller fuses in the under-hood fuse box and all the fuses in the interior fuse box by pulling out each fuse with the fuse puller provided in the under-hood fuse box.

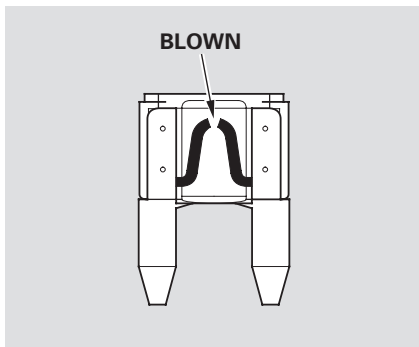

5. Look for a burned wire inside the fuse. If it is burned, replace it with one of the spare fuses of the same rating or lower.

If you cannot drive the car without fixing the problem, and you do not have a spare fuse, take a fuse of the same rating or a lower rating from one of the other circuits. Make sure you can do without that circuit temporarily (such as the accessory power socket or radio).

If you replace the blown fuse with a spare fuse that has a lower rating, it might blow out again. This does not indicate anything wrong. Replace the fuse with one of the correct rating as soon as you can.

### NOTICE

*Replacing a fuse with one that has a higher rating greatly increases the chances of damaging the electrical system. If you do not have a replacement fuse with the proper rating for the circuit, install one with a lower rating.*

6. If the replacement fuse of the same rating blows in a short time, there is probably a serious electrical problem in your car. Leave the blown fuse in that circuit and have your car checked by a qualified mechanic.

*CONTINUED*



# Fuses

## UNDER-HOOD FUSE/RELAY BOX

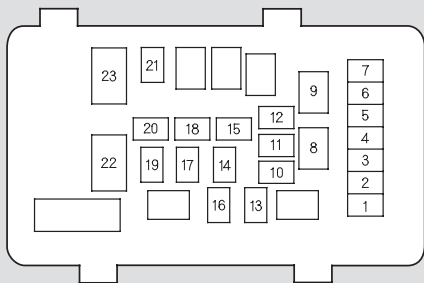

No.	Amps.	Circuits Protected
1	15 A	Left Headlight Low
2	(30A)	(Rear Defroster Coil)
3	10 A	Left Headlight Hi
4	15 A	Small Light
5	10 A	Right Headlight Hi

No.	Amps.	Circuits Protected
6	15 A	Right Headlight Low
7	7.5 A	Back Up
8	15 A	FI ECU
9	20 A	Condenser fan
10	—	Not Used

No.	Amps.	Circuits Protected
11	20 A	Cooling Fan
12	—	Not Used
13	20 A	Horn, Stop
14	40 A	Rear Defroster
15	40 A	Back Up, ACC
16	15 A	Hazard
17	30 A	VSA Motor
18	40 A	VSA
19	40 A	OP 1
20	40 A	OP 2
21	40 A	Heater Motor
22	100 A	Battery
	—	Not Used
23	50 A	+ B IG1 Main
	50 A	Power Window Main

## INTERIOR FUSE BOX

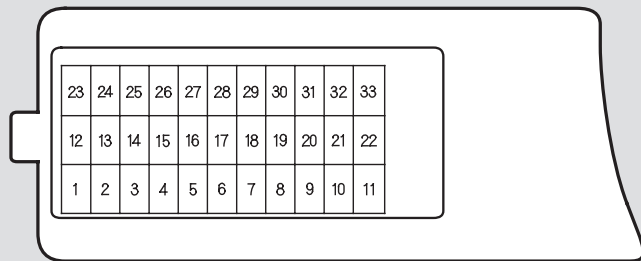

No.	Amps.	Circuits Protected
1	(15 A)	DBW
2	15 A	Ignition Coil
3	(10 A)	Day Light*
4	10 A	LAF
5	20 A	Audio Amp
6	10 A	Interior Light

No.	Amps.	Circuits Protected
7	10 A	Back-Up Lights
8	20 A	Door Lock
9	15 A	Front Accessory Sockets
10	7.5 A	IG OPDS
11	30 A	IG Wiper
12	—	Not Used

No.	Amps.	Circuits Protected
13	—	Not Used
14	(20 A)	Driver's Power Seat Sliding
15	(20 A)	Heated Seat
16	(20 A)	Driver's Power Seat Reclining
17	—	Not Used
18	15 A	IG ACG
19	15 A	IG Fuel Pump
20	7.5 A	IG Washer
21	7.5 A	IG Meter
22	10 A	IG SRS
23	7.5 A	IGP (PGM-FI ECU)
24	20 A	Left Rear Power Window
25	20 A	Right Rear Power Window
26	20 A	Right Front Power Window
27	20 A	Driver's Power Window
28	(20 A)	Moonroof
29	—	Not Used
30	7.5 A	IG HAC
31	—	Not Used
32	7.5 A	ACC
33	7.5 A	HAC OP

\* : On Canadian models

## Emergency Towing

---

If your car needs to be towed, call a professional towing service or, if you belong to one, an organization that provides roadside assistance. Never tow your car behind another vehicle with just a rope or chain. It is very dangerous.

There are three popular types of professional towing equipment.

**Flat-bed Equipment** — The operator loads your car on the back of a truck. **This is the best way to transport your Acura.**

**Wheel-lift Equipment** — The tow truck uses two pivoting arms that go under the tires (front or rear) and lift them off the ground. The other two tires remain on the ground. **This is an acceptable way to tow your Acura.**

**Sling-type Equipment** — The tow truck uses metal cables with hooks on the ends. These hooks go around parts of the frame or suspension and the cables lift that end of the car off the ground. Your car's suspension and body can be seriously damaged. **This method of towing is unacceptable.**

If your Acura cannot be transported by flat-bed, it should be towed by wheel-lift equipment with the front wheels off the ground. If, due to damage, your car must be towed with the front wheels on the ground, do the following.

*Manual Transmission:*

- Release the parking brake.
- Shift the transmission to Neutral.

*Automatic Transmission:*

- Release the parking brake.
- Start the engine.
- Shift to D, then to N.
- Turn off the engine.

### NOTICE

*Improper towing preparation will damage the transmission. Follow the above procedure exactly. If you cannot shift the transmission or start the engine (automatic transmission), your car must be transported with the front wheels off the ground.*

With the front wheels on the ground, it is best to tow the car no farther than 50 miles (80 km), and keep the speed below 35 mph (55 km/h).

If your car is equipped with a front spoiler, remove it before towing so it is not damaged.

If you decide to tow your car with all four wheels on the ground, make sure you use a properly-designed and attached tow bar. Prepare the car for towing as described above, and leave the ignition switch in Accessory (I) so the steering wheel does not lock. Make sure the radio and any items plugged into the accessory power socket are turned off so they do not run down the battery.

### NOTICE

*The steering system can be damaged if the steering wheel is locked. Leave the ignition switch in Accessory (I), and make sure the steering wheel turns freely before you begin towing.*

### NOTICE

*Trying to lift or tow your car by the bumpers will cause serious damage. The bumpers are not designed to support the car's weight.*



The diagrams in this section give you the dimensions and capacities of your Acura, and the locations of the identification numbers. It also includes information you should know about your car's tires and emissions control systems.

Identification Numbers.....	332	Oxygenated Fuels.....	340
Specifications .....	334	Driving in Foreign Countries .....	341
DOT Tire Quality Grading		Emissions Controls.....	342
(U.S. Cars).....	337	The Clean Air Act.....	342
Treadwear .....	337	Crankcase Emissions Control	
Traction.....	337	System.....	342
Temperature .....	338	Evaporative Emissions Control	
Tire Information .....	339	System.....	342
		Onboard Refueling Vapor	
		Recovery .....	342
		Exhaust Emissions Controls ...	343
		PGM-FI System .....	343
		Ignition Timing Control	
		System.....	343
		Three Way Catalytic	
		Converter.....	343
		Replacement Parts.....	343
		Three Way Catalytic Converter...	344
		State Emissions Testing .....	345

## Identification Numbers

---

Your car has several identifying numbers located in various places.

The Vehicle Identification Number (VIN) is the 17-digit number your Acura dealer uses to register your car for warranty purposes. It is also necessary for licensing and insuring your car. The easiest place to find the VIN is on a plate fastened to the top of the dashboard. You can see it by looking through the windshield on the driver's side. It is also on the Certification label attached to the driver's doorjamb, and is stamped on the engine compartment bulkhead. The VIN is also provided in bar code on the Certification label.

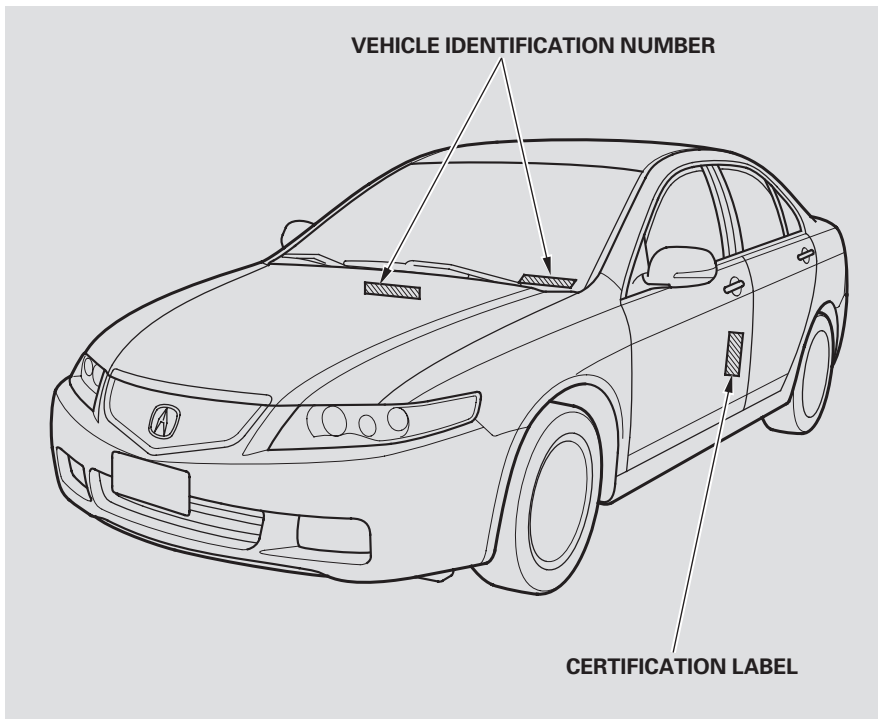

## Identification Numbers

The Engine Number is stamped into the engine block. It is on the front.

The Transmission Number is on a label on top of the transmission.

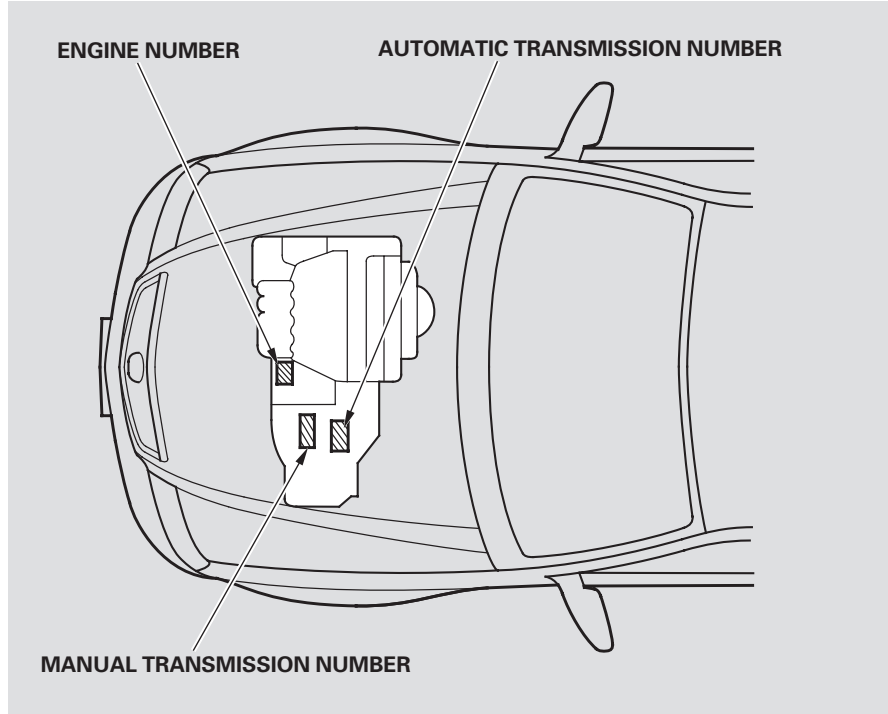



# Specifications

## Dimensions

Length	183.3 in (4,657 mm)
Width	69.4 in (1,762 mm)
Height	57.3 in (1,456 mm)
Wheelbase	105.1 in (2,670 mm)
Track	Front 59.6 in (1,515 mm)
	Rear 59.6 in (1,515 mm)

## Weights

Gross vehicle weight rating	See the certification label attached to the driver's doorjamb.
-----------------------------	--

## Air Conditioning

Refrigerant type	HFC-134a (R-134a)
Charge quantity	25–27 oz (700–750 g)
Lubricant type	ND-OIL8

## Capacities

Fuel tank	Approx. 17.1 US gal (64.7 ℓ)
-----------	---------------------------------

## Capacities

Engine coolant	Change* <sup>1</sup>	
	Manual	1.43 US gal (5.4 ℓ)
	Automatic	1.40 US gal (5.3 ℓ)
	Total	
	Manual	1.96 US gal (7.4 ℓ)
	Automatic	1.93 US gal (7.3 ℓ)
Engine oil	Change* <sup>2</sup>	
	Including filter	4.4 US qt (4.2 ℓ)
	Without filter	4.2 US qt (4.0 ℓ)
	Total	5.6 US qt (5.3 ℓ)
Manual transmission oil	Change	2.1 US qt (2.0 ℓ)
	Total	2.3 US qt (2.2 ℓ)
Automatic transmission fluid	Change	3.0 US qt (2.8 ℓ)
	Total	6.9 US qt (6.5 ℓ)
Windshield washer reservoir	U.S. Cars	2.6 US qt (2.5 ℓ)
	Canada Cars	4.8 US qt (4.5 ℓ)

\* 1 : Including the coolant in the reserve tank and that remaining in the engine.

Reserve tank capacity: 0.16 US gal (0.6 ℓ)

\* 2 : Excluding the oil remaining in the engine.

# Specifications

## Lights

Headlights	High	12 V – 55 W
	Low	12 V – 35 W
Front turn signal		12 V – 21 W
Front parking lights		12 V – 3 CP
Rear turn signal lights		12 V – 21 W
Stop/Taillights		12 V – 21/5 W
Taillights		12 V – 5 W
High-mount brake light		12 V – 21 W
Back-up lights		12 V – 21 W
Rear side marker light		12 V – 3 CP
License plate light		12 V – 3 CP
Ceiling light		12 V – 8 W
Spotlights/Front ceiling lights		12 V – 8 W
Trunk light		12 V – 5 W
Door courtesy light		12 V – 2 CP
Vanity mirror lights		12 V – 1.1 W

## Battery

Capacity	12 V – 38 AH/5 HR
----------	-------------------

## Fuses

Interior	See page <a href="#">327</a> or the fuse label attached to the inside of the fuse box door on each side of the dashboard.
Under-hood	See page <a href="#">326</a> or the fuse box cover.

## Engine

Type	Water cooled 4-stroke, DOHC i-VTEC 4-cylinder, gasoline engine
Bore x Stroke	3.43 x 3.90 in (87.0 x 99.0 mm)
Displacement	144 cu-in (2,354 cm <sup>3</sup> )
Compression ratio	10.5 : 1
Spark plugs	See spark plug maintenance section page <a href="#">264</a> .

## Alignment

Toe-in	Front	0.00 in (0.0 mm)
	Rear	0.08 in (2.0 mm)
Camber	Front	0°
	Rear	-1°
Caster	Front	3°13'

CONTINUED

# Specifications

---

## Tires

Size	Front/Rear	P215/50R17 93V
	Spare	T135/90D15
Pressure	Front	32 psi (220 kPa , 2.2 kgf/cm <sup>2</sup> )
	Rear	30 psi (210 kPa , 2.1 kgf/cm <sup>2</sup> )
	Spare	60 psi (420 kPa , 4.2 kgf/cm <sup>2</sup> )

The tires on your car meet all U.S. Federal Safety Requirements. All tires are also graded for treadwear, traction, and temperature performance according to Department of Transportation (DOT) standards. The following explains these gradings.

### **Uniform Tire Quality Grading**

Quality grades can be found where applicable on the tire sidewall between the tread shoulder and the maximum section width. For example:

**Treadwear 200**

**Traction AA**

**Temperature A**

All passenger car tires must conform to Federal Safety Requirements in addition to these grades.

### **Treadwear**

The treadwear grade is a comparative rating based on the wear rate of the tire when tested under controlled conditions on a specified government test course. For example, a tire graded 150 would wear one and one-half (1 1/2) times as well on the government course as a tire graded 100. The relative performance of tires depends upon the actual conditions of their use, however, and may depart significantly from the norm due to variations in driving habits, service practices and differences in road characteristics and climate.

### **Traction — AA, A, B, C**

The traction grades, from highest to lowest, are AA, A, B, and C. Those grades represent the tire's ability to stop on wet pavement as measured under controlled conditions on specified government test surfaces of asphalt and concrete. A tire marked C may have poor traction performance.

**Warning:** The traction grade assigned to this tire is based on straight-ahead braking traction tests, and does not include acceleration, cornering, hydroplaning, or peak traction characteristics.

## DOT Tire Quality Grading (U.S. Cars)

---

### Temperature – A, B, C

The temperature grades are A (the highest), B, and C, representing the tire's resistance to the generation of heat and its ability to dissipate heat when tested under controlled conditions on a specified indoor laboratory test wheel. Sustained high temperature can cause the material of the tire to degenerate and reduce tire life, and excessive temperature can lead to sudden tire failure. The grade C corresponds to a level of performance which all passenger car tires must meet under the Federal Motor Vehicle Safety Standard No. 109. Grades B and A represent higher levels of performance on the laboratory test wheel than the minimum required by law.

Warning: The temperature grade for this tire is established for a tire that is properly inflated and not overloaded. Excessive speed, underinflation, or excessive loading, either separately or in combination, can cause heat buildup and possible tire failure.

### Tire Labeling

The tires that came on your vehicle have a number of markings. Those you should be aware of are described below.

### Tire Size

Whenever tires are replaced, they should be replaced with tires of the same size. Following is an example tire size with an explanation of what each component means.

P225/55R16 94V

- P — Vehicle type (P indicates passenger vehicle).
- 225 — Tire width in millimeters.
- 55 — Aspect ratio (the tire's section height as a percentage of its width).
- R — Tire construction code (R indicates radial).

- 16 — Rim diameter in inches.
- 94 — Load index (a numerical code associated with the maximum load the tire can carry).
- V — Speed symbol (an alphabetical code indicating the maximum speed rating).

### Tire Identification Number

Tire Identification Number (TIN) is a group of numbers and letters that look like the following example TIN.

DOT B97R FW6X 2202

- DOT — This indicates that the tire meets all requirements of the U.S. Department of Transportation.
- B97R — Manufacturer's identification mark.
- FW6X — Tire type code.

- 2202 — Date of manufacture.

## Oxygenated Fuels

---

Some conventional gasolines are being blended with alcohol or an ether compound. These gasolines are collectively referred to as oxygenated fuels. To meet clean air standards, some areas of the United States and Canada use oxygenated fuels to help reduce emissions.

If you use an oxygenated fuel, be sure it is unleaded and meets the minimum octane rating requirement.

Before using an oxygenated fuel, try to confirm the fuel's contents. Some states/provinces require this information to be posted on the pump.

The following are the U.S. EPA and Canadian CGSB approved percentages of oxygenates:

### **ETHANOL** (ethyl or grain alcohol)

You may use gasoline containing up to 10 percent ethanol by volume. Gasoline containing ethanol may be marketed under the name "Gasohol."

### **MTBE** (Methyl Tertiary Butyl Ether)

You may use gasoline containing up to 15 percent MTBE by volume.

### **METHANOL** (methyl or wood alcohol)

Your car was not designed to use fuel that contains methanol.

Methanol can corrode metal parts in the fuel system, and also damage plastic and rubber components. This damage would not be covered by your warranties.

If you notice any undesirable operating symptoms, try another service station or switch to another brand of gasoline.

Fuel system damage or performance problems resulting from the use of an oxygenated fuel containing more than the percentages of oxygenates given above are not covered under warranty.

If you are planning to take your Acura outside the U.S. or Canada, contact the tourist bureaus in the areas you will be traveling in to find out about the availability of unleaded gasoline with the proper octane rating.

If unleaded gasoline is not available, be aware that using leaded gasoline in your Acura will affect performance and fuel mileage, and damage its emissions controls. It will no longer comply with U.S. and Canadian emissions regulations, and will be illegal to operate in North America. To bring your car back into compliance will require the replacement of several components, such as the oxygen sensors and the three way catalytic converter. These replacements are not covered under warranty.



## Emissions Controls

---

The burning of gasoline in your car's engine produces several byproducts. Some of these are carbon monoxide (CO), oxides of nitrogen (NOx) and hydrocarbons (HC). Gasoline evaporating from the tank also produces hydrocarbons. Controlling the production of NOx, CO, and HC is important to the environment. Under certain conditions of sunlight and climate, NOx and HC react to form photochemical "smog." Carbon monoxide does not contribute to smog creation, but it is a poisonous gas.

### **The Clean Air Act**

The United States Clean Air Act\* sets standards for automobile emissions. It also requires that automobile manufacturers explain to owners how their emissions controls work and what to do to maintain them. This section summarizes how the emissions controls work. Scheduled maintenance is on page [232](#).

\* In Canada, Acura vehicles comply with the Canadian emission requirements, as specified in an agreement with Environment Canada, at the time they are manufactured.

### **Crankcase Emissions Control System**

Your car has a Positive Crankcase Ventilation System. This keeps gasses that build up in the engine's crankcase from going into the atmosphere. The Positive Crankcase

Ventilation valve routes them from the crankcase back to the intake manifold. They are then drawn into the engine and burned.

### **Evaporative Emissions Control System**

As gasoline evaporates in the fuel tank, an evaporative emissions control canister filled with charcoal adsorbs the vapor. It is stored in this canister while the engine is off. After the engine is started and warmed up, the vapor is drawn into the engine and burned during driving.

### **Onboard Refueling Vapor Recovery**

The Onboard Refueling Vapor Recovery (ORVR) system captures the fuel vapors during refueling. The vapors are adsorbed in a canister filled with activated carbon. While driving, the fuel vapors are drawn into the engine and burned off.

### **Exhaust Emissions Controls**

The exhaust emissions controls include three systems: PGM-FI, Ignition Timing Control, and Three Way Catalytic Converter. These three systems work together to control the engine's combustion and minimize the amount of HC, CO, and NOx that comes out the tailpipe. The exhaust emissions control systems are separate from the crankcase and evaporative emissions control systems.

#### ***PGM-FI System***

The PGM-FI System uses sequential multiport fuel injection. It has three subsystems: Air Intake, Engine Control, and Fuel Control. The Engine Control Module (ECM) or the Powertrain Control Module (PCM) uses various sensors to determine how much air is going into the engine. It then controls how much fuel to inject under all operating conditions.

#### ***Ignition Timing Control System***

This system constantly adjusts the ignition timing, reducing the amount of HC, CO, and NOx produced.

#### ***Three Way Catalytic Converter***

The three way catalytic converter is in the exhaust system. Through chemical reactions, it converts HC, CO, and NOx in the engine's exhaust to carbon dioxide (CO<sub>2</sub>), nitrogen (N<sub>2</sub>), and water vapor.

### **Replacement Parts**

The emissions control systems are designed and certified to work together in reducing emissions to levels that comply with the Clean Air Act. To make sure the emissions remain low, you should use only new Acura replacement parts or their equivalent for repairs. Using lower quality parts may increase the emissions from your car.

The emissions control systems are covered by warranties separate from the rest of your car. Read your warranty manual for more information.

## Three Way Catalytic Converter

---

The three way catalytic converter contains precious metals that serve as catalysts, promoting chemical reactions to convert the exhaust gasses without affecting the metals. The catalytic converter is referred to as a three-way catalyst, since it acts on HC, CO, and NOx. A replacement unit must be an original Acura part or its equivalent.

The three way catalytic converter must operate at a high temperature for the chemical reactions to take place. It can set on fire any combustible materials that come near it. Park your car away from high grass, dry leaves, or other flammables.

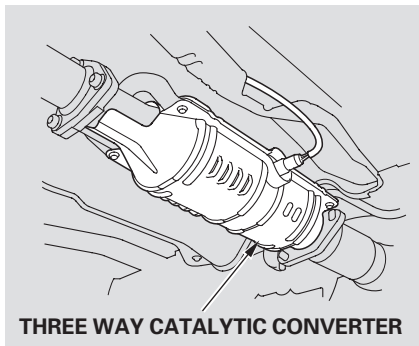

A defective three way catalytic converter contributes to air pollution, and can impair your engine's performance. Follow these guidelines to protect your car's three way catalytic converter.

- Always use unleaded gasoline. Even a small amount of leaded gasoline can contaminate the catalyst metals, making the three way catalytic converter ineffective.

- Keep the engine tuned-up.
- Have your car diagnosed and repaired if it is misfiring, back-firing, stalling, or otherwise not running properly.

### Testing of Readiness Codes

If you take your car for a state emissions test shortly after the battery has been disconnected or gone dead, it may not pass the test. This is because of certain “readiness codes” that must be set in the on-board diagnostics for the emissions systems. These codes are erased when the battery is disconnected, and set again only after several days of driving under a variety of conditions.

If the testing facility determines that the readiness codes are not set, you will be requested to return at a later date to complete the test. If you must get the car re-tested within the next two or three days, you can condition the car for re-testing by doing the following.

- Make sure the gas tank is nearly, but not completely, full (around 3/4).
- Make sure the car has been parked with the engine off for 8 hours or more.
- Make sure the ambient temperature is between 20° and 95° F.

- Without touching the accelerator pedal, start the engine and let it idle for 20 seconds.
- Keep the car in Park (automatic transmission) or Neutral (manual transmission). Increase the engine speed to 2,000 rpm and hold it there until the temperature gauge rises to at least 1/4 of the scale (approximately 3 minutes).

*CONTINUED*

## State Emissions Testing

---

- Select a nearby lightly traveled major highway where you can maintain a speed of 50 to 60 mph (80 to 97 km/h) for at least 20 minutes. Drive on the highway in D (A/T) or 6th (M/T). Do not use the cruise control. When traffic allows, drive for 90 seconds without moving the accelerator pedal. (Car speed may vary slightly; this is okay.) If you cannot do this for a continuous 90 seconds because of traffic conditions, drive for at least 30 seconds, then repeat it two more times (for a total of 90 seconds).

- Then drive in city/suburban traffic for at least 10 minutes. When traffic conditions allow, let the car coast for several seconds without using the accelerator pedal or the brake pedal.

If the testing facility determines the readiness codes are still not set, see your Acura dealer.

## Warranty and Customer Relations

---

Customer Relations Information.....	348
Warranty Coverages .....	349
Reporting Safety Defects (U.S. Cars) .....	350
Authorized Manuals.....	351

## Customer Relations Information

---

Acura dealership personnel are trained professionals. They should be able to answer all your questions. If you encounter a problem that your dealership does not solve to your satisfaction, please discuss it with the dealership's management. The Service Manager or General Manager can help. Almost all problems are solved in this way.

If you are dissatisfied with the decision made by the dealership's management, contact the Acura Customer Relations Office.

### U.S. Owners:

American Honda Motor Co., Inc.  
Acura Client Services  
Mail Stop 500-2N-7E  
1919 Torrance Blvd.  
Torrance, CA 90501-2746

Tel: (800) 382-2238

In Puerto Rico and the U.S. Virgin Islands:

Vortex Motor Corp.  
Bella International  
P.O. Box 190816  
San Juan, PR 00919-0816

Tel: (787) 250-4327

Canadian Owners:

### **CUSTOMER RELATIONS RELATIONS AVEC LA CLIENTÉLE**

Honda Canada Inc.  
715 Milner Avenue  
Toronto, ON  
M1B 2K8

Tel: 1-888-9-ACURA-9

Fax: Toll-free 1-877-939-0909  
Toronto (416) 287-4776

When you call or write, please give us this information:

- Vehicle Identification Number (see page 332)
- Name and address of the dealer who services your car
- Date of purchase
- Mileage on your car
- Your name, address, and telephone number
- A detailed description of the problem
- Name of the dealer who sold the car to you

### **U.S. Owners**

Your new Acura is covered by these warranties:

***New Car Limited Warranty*** — covers your new car, except for the battery, emissions control systems, and accessories, against defects in materials and workmanship.

***Emissions Control Systems Defects Warranty and Emissions Performance Warranty*** — these two warranties cover your car's emissions control systems. Time, mileage, and coverage are conditional. Please read the warranty manual for exact information.

***Original Equipment Battery Limited Warranty*** — this warranty gives up to 100 percent credit toward a replacement battery.

***Seat Belt Limited Warranty*** — a seat belt that fails to function properly is covered for the useful life of the car.

***Rust Perforation Limited Warranty*** — all exterior body panels are covered for rust-through from the inside for the specified time period with no mileage limit.

***Accessory Limited Warranty*** — Acura accessories are covered under this warranty. Time and mileage limits depend on the type of accessory and other factors. Please read your warranty manual for details.

***Replacement Parts Limited Warranty*** — covers all Acura replacement parts against defects in materials and workmanship.

***Replacement Battery Limited Warranty*** — provides prorated coverage for a replacement battery purchased from an Acura dealer.

***Replacement Muffler Lifetime Limited Warranty*** — provides coverage for as long as the purchaser of the muffler owns the car.

Restrictions and exclusions apply to all these warranties. Please read the 2004 Acura Warranty Information booklet that came with your car for precise information on warranty coverages. Your Acura's original tires are covered by their manufacturer. Tire warranty information is in a separate booklet.

### **Canadian Owners**

Please refer to the 2004 Warranty Manual that came with your car.



## Reporting Safety Defects (U.S. Cars)

---

If you believe that your car has a defect which could cause a crash or could cause injury or death, you should immediately inform the National Highway Traffic Safety Administration (NHTSA) in addition to notifying Acura Automobile Division, American Honda Motor Co., Inc.

If NHTSA receives similar complaints, it may open an investigation, and if it finds that a safety defect exists in a group of cars, it may order a recall and remedy campaign. However, NHTSA cannot become involved in individual problems between you, your dealer, or Acura Automobile Division, American Honda Motor Co., Inc.

To contact NHTSA, you may either call the Auto Safety Hotline toll-free at 1-800-424-9393 (or 366-0123 in Washington D.C. area) or write to: NHTSA, U.S. Department of Transportation, Washington, D.C. 20590. You can also obtain other information about motor vehicle safety from the Hotline.

## Purchasing Factory Authorized Manuals (U.S. only)

The publications shown below can be purchased from Helm Incorporated. You can order in any of three ways:

- Detach and mail the order form on the right half of this page
- Call Helm Inc. at 1-800-782-4356 (credit card orders only)
- Go online at [www.helminc.com](http://www.helminc.com)

If you are interested in other years or models, contact Helm Inc. at 1-800-782-4356

Publication Form Number	Form Description	Price Each*
61SEA00	2004 Acura TSX Service Manual	\$69.00
61SEA00EL	2004 Acura TSX Electrical Troubleshooting Manual	\$47.00
61SEA30	2004 Acura TSX Body Repair Manual	\$44.00
31SEA600	2004 Acura TSX Owner's Manual	\$37.00
31SEA700	2004 Acura TSX Navigation System Owner's Manual	\$29.00
31SEAQ00	2004 Acura TSX Quick Start Guide	\$10.00
ACU-R	Order Form for Previous Years- Indicate Year and Model Desired	FREE

\* Prices are subject to change without notice and without incurring obligation.

*Valid only for sales within the U.S. Canadian owners should contact their authorized Acura dealer.*

**ORDER TOLL FREE: 1-800-782-4356**

**(NOTE: For Credit Card Holder Orders Only)**

Monday-Friday 8:00 A.M. — 6:00 P.M. EST

**MINIMUM CREDIT CARD PURCHASE \$10.00**

**OR**

By completing this form you can order the materials desired. You can pay by check or money order, or charge to your credit card. Mail to Helm Incorporated at the address shown on the back of the order form.

2004 ACU	PUBLICATION NUMBER	VEHICLE MODEL		Qty	Price Each*	Total Price
		Name	Year			
* Prices are subject to change without notice and without incurring obligation.					TOTAL MATERIAL	
					Mich. Purchases Add 6% Sales Tax	
Orders are mailed within 10 days. Please allow adequate time for delivery.					HANDLING CHARGE \$6.00	
					GRAND TOTAL	



## A

Accessories and Modifications ....	191
Accessories.....	191
Additional Safety Precautions..	192
Modifications .....	192
ACCESSORY (Ignition Key Position) .....	81
Accessory Power Socket .....	109
Additives, Engine Oil.....	246
Airbag (SRS) .....	9
Air Cleaner Element.....	261
Air Conditioning.....	115
Maintenance.....	269
Usage .....	115
Air Pressure, Tires .....	273
Alcohol in Gasoline.....	340
Antifreeze .....	249
Anti-lock Brakes (ABS) Description .....	213
Indicator.....	61, 214
Operation.....	213
Anti-theft Steering Column Lock ..	80
Appearance Care .....	295
Armrest.....	105
Audio System .....	129, 148

Automatic Speed Control.....	174
Automatic Transmission.....	204
Capacity, Fluid .....	334
Checking Fluid Level.....	256
Shifting.....	204
Shift Lever Position Indicator ..	204
Shift Lever Positions .....	204
Shift Lock Release.....	210

## B

Battery	
Charging System Light.....	60, 318
Jump Starting .....	312
Maintenance.....	265
Specifications .....	335
Before Driving .....	183
Belts, Seat .....	8
Beverage Holders.....	106
Body Repair .....	312
Brakes	
Anti-lock System (ABS) .....	213
Break-in, New Linings .....	184
Bulb Replacement .....	286
Fluid .....	259
Parking.....	104

System Indicator.....	60
Wear Indicators .....	212
Braking System.....	213
Break-in, New Car .....	184
Brightness Control, Instruments...	72
Brights, Headlights .....	70
Bulb Replacement	
Back-up Lights .....	287
Brake Lights.....	286
Ceiling Light.....	290
Door Courtesy Light .....	291
Front Parking Lights.....	285
Headlights .....	282
High-mount Brake Light .....	289
License Plate Light.....	289
Specifications .....	335
Spotlights.....	290
Trunk Light .....	292
Turn Signal Lights.....	284
Vanity Mirror Lights.....	291
Bulbs, Halogen.....	282

CONTINUED

# Index

---

## C

Capacities Chart.....	334
Carbon Monoxide Hazard .....	53
Carrying Cargo .....	193
CAUTION, Explanation of .....	ii
CD Changer .....	136, 156
CD Pocket, Center.....	107
Certification Label.....	332
Chains .....	278
Changing a Flat Tire .....	305
Changing Engine Coolant.....	251
Changing Oil	
How to.....	246
When to.....	234
Charging System Indicator ....	60, 318
Checklist, Before Driving.....	198
Childproof Door Locks .....	87
Child Seats.....	26
Tether Anchorage Points .....	39
Cleaner, Air .....	261
Cleaning	
Aluminum Wheels.....	297
Carpeting .....	298
Exterior .....	296
Fabric .....	299

Interior .....	298
Leather.....	299
Seat Belts.....	299
Vinyl .....	299
Window .....	300
Climate Control System.....	114
Clock, Setting the .....	135, 153
Clutch Fluid.....	260
CO in the Exhaust .....	342
Cold Weather, Starting in.....	200
Compact Spare .....	304
Console Compartment.....	105
Consumer Information*.....	348
Controls, Instruments and.....	57
Coolant	
Adding.....	249
Checking.....	189
Proper Solution .....	249
Temperature Gauge.....	66
Corrosion Protection.....	311
Crankcase Emissions Control	
System.....	342
Cruise Control Operation .....	174
Customer Relations Office .....	348

## D

DANGER, Explanation of.....	ii
Dashboard .....	58
Daytime Running Lights.....	72
Defects, Reporting Safety.....	350
Defogger, Rear Window .....	75
Dimensions.....	334
Dimming the Headlights .....	70
Dipstick	
Automatic Transmission.....	256
Engine Oil.....	187
Directional Signals.....	73
Disc Brake Wear Indicators.....	212
Disposal of Used Oil.....	248
Doors	
Locking and Unlocking.....	81
DOT Tire Quality Grading.....	337
Downshifting, 5-speed Manual	
Transmission.....	201
Drive Belts.....	272
Driver and Passenger Safety.....	5
Driving .....	197
Economy .....	190
In Bad Weather.....	219
In Foreign Countries.....	341

Dust and Pollen Filter ..... 270

## E

Economy, Fuel ..... 190

Emergencies on the Road..... 303

    Battery, Jump Starting ..... 312

    Brake System Indicator ..... 321

    Changing a Flat Tire ..... 305

    Charging System Indicator ..... 318

    Checking the Fuses..... 324

    Low Oil Pressure Indicator ..... 317

    Malfunction Indicator Lamp .... 319

    Manually Closing Moonroof .... 322

    Overheated Engine ..... 315

Emergency Brake ..... 104

Emergency Flashers ..... 75

Emergency Towing ..... 328

Emissions Controls..... 342

Engine

    Belts..... 272

    Coolant Temperature Gauge .... 66

    Malfunction Indicator

        Lamp ..... 60, 319

    Oil Pressure Indicator ..... 60, 317

    Oil, What Kind to Use ..... 244

    Overheating..... 315

    Specifications ..... 335

    Speed Limiter ..... 202, 209

    Starting..... 199

Engine Speed Limiter ..... 202, 209

Ethanol in Gasoline ..... 340

Evaporative Emissions Controls.. 342

Exhaust Fumes..... 53

Expectant Mothers, Use of Seat

    Belts by ..... 19

Exterior, Cleaning the..... 296

## F

Fabric, Cleaning..... 299

Fan, Interior..... 115

Features, Comfort and

    Convenience ..... 113

Filling the Fuel Tank..... 184

Filter

    Dust and Pollen..... 270

    Oil ..... 246

Flashers, Hazard Warning..... 75

Flat Tire, Changing a ..... 305

Fluids

    Automatic Transmission..... 256

    Brake..... 259

    Clutch..... 260

    Manual Transmission ..... 257

    Power Steering..... 260

    Windshield Washer ..... 255

Folding Rear Seat ..... 94

Foreign Countries, Driving in ..... 341

Four-way Flashers ..... 75

Fuel..... 184

    Fill Door and Cap..... 185

    Gauge ..... 67

    Octane Requirement ..... 184

    Oxygenated ..... 340

    Tank, Filling the..... 184

Fuses, Checking the..... 324

## G

Gas Mileage, Improving..... 190

Gasohol ..... 340

Gasoline ..... 184

    Gauge ..... 67

    Octane Requirement ..... 184

    Tank, Filling the..... 184

*CONTINUED*

# Index

---

Gas Station Procedures.....	184
Gauges	
Engine Coolant Temperature ....	66
Fuel.....	67
Speedometer .....	65
Tachometer .....	65
Gearshift Lever Positions	
Automatic Transmission.....	204
6-speed Manual	
Transmission.....	201
Glass Cleaning .....	300
Glove Box .....	89

## H

Halogen Headlight Bulbs.....	282
Hazard Warning Flashers.....	75
Headlights.....	70
Aiming.....	282
Automatic Lighting Off.....	71
Daytime Running Lights.....	72
Low Beams, Turning on .....	70
Reminder Chime.....	70
Replacing Halogen Bulbs .....	282
Turning on.....	70
Head Restraints .....	93

Heating and Cooling.....	114
Heated Mirror .....	103
High Altitude, Starting at.....	200
HomeLink Wireless Control	
System.....	177
Hood, Opening the .....	186
Hydraulic Clutch.....	260
Hydroplaning.....	220

## I

Identification Number, Vehicle....	332
Ignition	
Keys.....	77
Switch.....	80
Timing Control System.....	343
Immobilizer System.....	79
Important Safety Precautions .....	6
Indicators, Instrument Panel.....	59
Infant Restraint .....	30
Infant Seats.....	30
Tether Anchorage Points .....	39
Inflation, Proper Tire .....	273
Inside Mirror.....	102
Inspection, Tire.....	275
Instrument Panel .....	59

Instrument Panel Brightness .....	72
Interior Cleaning.....	298
Interior Lights .....	110
Introduction.....	i

## J

Jacking up the Car .....	307
Jack, Tire .....	305
Jump Starting .....	312

## K

Keys.....	77
-----------	----

## L

Label, Certification .....	332
Lane Change, Signaling .....	73
Lap/Shoulder Belts .....	43
Leather, Cleaning .....	299
Lights	
Bulb Replacement .....	282
Indicator .....	59
Parking.....	70
Turn Signal.....	73

LOCK (Ignition Key Position) .....	80
Locks	
Anti-theft Steering Column .....	80
Fuel Fill Door .....	184
Glove Box .....	89
Trunk .....	87
Low Coolant Level.....	189
Lower Gear, Downshifting to a....	201
Low Oil Pressure Indicator ....	60, 317
Lubricant Specifications Chart ....	334
Luggage .....	193

## M

Maintenance.....	229
Owner Maintenance Checks....	242
Record.....	239
Required Indicator.....	67
Safety.....	230
Schedule .....	234-238
Malfunction Indicator Lamp ..	60, 319
Manual Transmission.....	202
Manual Transmission Fluid .....	257
Meters, Gauges.....	65
Methanol in Gasoline .....	340
Mirrors, Adjusting .....	102

Moonroof .....	101
Closing Manually .....	322
Operation .....	101

## N

Neutral Gear Position.....	206
New Vehicle Break-in .....	184
Normal Shift Speeds.....	202
NOTICE, Explanation of.....	ii
Numbers, Identification .....	332

## O

Octane Requirement, Gasoline....	184
Odometer.....	65
Odometer/Outside Temperature	
Indicator .....	66
Odometer, Trip .....	66
Oil	
Change, How to .....	246
Change, When to .....	232
Checking Engine .....	187
Pressure Indicator .....	60, 317
Selecting Proper Viscosity	
Chart .....	245

ON (Ignition Key Position) .....	81
Operation in Foreign Countries...	341
Outside Mirrors .....	102
Outside Temperature.....	66
Overheating, Engine .....	315
Owner Maintenance Checks.....	242
Oxygenated Fuel .....	340

## P

Panel Brightness Control .....	72
Park Gear Position.....	205
Parking .....	211
Parking Brake .....	104
Parking Lights.....	70
Parking Over Things that Burn...	344
PGM-FI System.....	343
Polishing and Waxing .....	297
Pollen Filter .....	270
Pre-Drive Safety Checklist .....	11
Pregnancy, Using Seat Belts .....	19
Protecting Adults.....	12
Additional Safety Precautions....	20
Advice for Pregnant Women.....	19

CONTINUED



# Index

---

Protecting Children .....	21
Protecting Infants .....	30
Protecting Larger Children .....	36
Protecting Small Children .....	33
Using Child Seats with Tethers .....	39
Using LATCH .....	41

## R

Radiator Overheating .....	315
Radio/CD Sound System .....	129, 148
Rear Lights, Bulb Replacement ...	286
Rear Seat Armrest .....	95
Rear Seat, Folding .....	94
Rear View Mirror .....	102
Rear Window Defogger .....	75
Reclining the Seat Backs .....	91, 92
Recommended Shift Speeds .....	202
Reminder Lights .....	59
Remote Transmitter .....	83
Replacement Information	
Air Cleaner Element .....	261
Coolant .....	251
Engine Oil and Filter .....	246
Fuses .....	324

Light Bulbs .....	282
Schedule .....	232
Spark Plugs .....	262
Tires .....	276
Wiper Blades .....	267
Replacing Seat Belts After a Crash .....	45
Reserve Tank, Coolant .....	189
Restraint, Child .....	21
Reverse Gear Position .....	206
Rotation, Tire .....	276

## S

Safety Belts .....	8
Safety Defects, Reporting* .....	350
Safety Features .....	7
Airbags .....	9
Door Locks .....	11
Head Restraints .....	11
Seat Belts .....	8
Seats and Seat-Backs .....	10
Safety Labels, Location of .....	54
Safety Messages .....	ii
Seat Belts .....	8
Additional Information .....	43

Automatic Seat Belt Tensioners .....	44
Cleaning .....	299
Lap/Shoulder Belt .....	43
Maintenance .....	45
Reminder Light and Beeper .....	43, 60
System Components .....	43
Use During Pregnancy .....	19
Seats, Adjusting the .....	90
Security System .....	173
Select/Reset Knob .....	68
Serial Number .....	332
Service Intervals .....	234
Service Manual* .....	351
Service Station Procedures .....	184
Setting the Clock .....	135, 153
Shift Lever Position Indicator .....	204
Shift Lock Release .....	210
Side Airbags .....	48
How Your Side Airbags Work ...	48
How The SIDE Airbag Cutoff Indicator Light Works .....	50
Side Curtain Airbags .....	49
How Your Side Curtain Airbags Work .....	49

- Signaling Turns..... 73  
 Snow Tires..... 278  
 Solvent-type Cleaners..... 296  
 Sound System..... 129, 148  
 Spare Tire  
   Inflating..... 304  
   Specifications ..... 336  
 Spark Plugs, Replacing ..... 262  
 Specifications Charts..... 334  
 Speed Control..... 174  
 Speed Limiter..... 202, 209  
 Speedometer ..... 65  
 SRS, Additional Information..... 46  
   Additional Safety Precautions... 52  
   How Your Airbags  
     Work ..... 46, 48, 49  
   How Your SRS Indicator  
     Works..... 49  
   SRS Components ..... 46  
   SRS Service..... 51  
 SRS Indicator..... 49, 61  
 START (Ignition Key Position) ..... 81  
 Starting the Engine..... 199  
   In Cold Weather at High  
     Altitude ..... 200  
   With a Dead Battery ..... 312  
 Steam Coming from Engine ..... 315  
 Steering Wheel  
   Adjustment ..... 76  
   Anti-theft Column Lock ..... 80  
 Stereo Sound  
   System..... 129, 148  
 Storing Your Car ..... 323  
 Sun Visor..... 108  
 Sunglasses Holder ..... 109  
 Supplemental Restraint System  
   Servicing ..... 51  
   SRS Indicator..... 49, 61  
   System Components..... 46  
 Synthetic Oil..... 245
- T**
- Tachometer ..... 65  
 Taillights, Changing Bulbs in..... 286  
 Taking Care of the Unexpected .. 303  
 Technical Descriptions  
   DOT Tire Quality Grading ..... 337  
   Emissions Control Systems..... 342  
   Oxygenated Fuels..... 340  
   Three Way Catalytic  
     Converter ..... 344  
 Tire Information ..... 339  
 Temperature Gauge ..... 66  
 Tether Anchorage Points ..... 39  
 Three Way Catalytic Converter... 344  
 Time, Setting the ..... 135, 153  
 Tire Chains ..... 278  
 Tire, How to Change a Flat ..... 305  
 Tires ..... 273  
   Air Pressure ..... 273  
   Checking Wear ..... 275  
   Compact Spare ..... 304  
   DOT Tire Quality Grading ..... 337  
   Inflation..... 273  
   Inspection ..... 275  
   Replacing ..... 276  
   Rotating..... 276  
   Snow ..... 278  
   Specifications ..... 336  
   Technical Information ..... 339  
 Tools, Tire Changing ..... 305  
 Towing  
   A Trailer..... 221  
   Emergency Wrecker ..... 328

CONTINUED

# Index

---

Transmission	
Checking Fluid Level, Automatic .....	256
Checking Fluid Level, Manual .....	257
Fluid Selection .....	256, 257
Identification Number .....	332
Shifting the Automatic .....	204
Shifting the Manual .....	201
Treadwear .....	337
Trip Meter .....	66
Trunk .....	87
Emergency Opener .....	88
Opening the .....	87
Open Monitor Light .....	62
Turn Signals .....	73

## U

Underside, Cleaning .....	311
Unexpected, Taking Care of the .....	303
Uniform Tire Quality Grading .....	337
Unleaded Gasoline .....	184
Upholstery Cleaning .....	298
Used Oil, How to Dispose of .....	248

Utility Pocket .....	107
----------------------	-----

## V

Vanity Mirror .....	108
Vehicle Capacity Load .....	193
Vehicle Dimensions .....	334
Vehicle Identification Number .....	332
Vehicle Stability Assist (VSA) System .....	216
VSA System Indicator .....	62, 217
VSA Activation Indicator .....	62, 216
VSA Off Switch .....	217
Vehicle Storage .....	293
VIN .....	332
Vinyl Cleaning .....	299
Viscosity, Oil .....	245

## W

WARNING, Explanation of .....	ii
Warning Labels, Location of .....	54
Warranty Coverages* .....	349
Washer, Windshield Checking the Fluid Level .....	255
Operation .....	75

Washing .....	296
Waxing and Polishing .....	297

## Wheels

Adjusting the Steering .....	76
Alignment and Balance .....	275
Compact Spare .....	304
Wrench .....	307

## Windows

Cleaning .....	300
Operating the Power .....	97
Rear, Defogger .....	75

## Windshield

Cleaning .....	73
Washers .....	75

## Wipers, Windshield

Changing Blades .....	267
Operation .....	73

Worn Tires .....	275
------------------	-----

Wrecker, Emergency Towing .....	328
---------------------------------	-----

\* : U.S. only

## Service Information Summary

---

### **Gasoline:**

Premium unleaded gasoline, pump octane number of 91 or higher.

### **Fuel Tank Capacity:**

17.1 US gal (64.7 ℓ)

### **Recommended Engine Oil:**

API Premium grade 5W-30 detergent oil (see page [244](#)).

Oil change capacity (including filter):

4.4 US qt (4.2 ℓ)

### **Automatic Transmission Fluid:**

Honda ATF-Z1 (Automatic Transmission Fluid) preferred, or a DEXRON® III ATF as a temporary replacement (see page [256](#)).

### **6-speed Manual Transmission Fluid:**

Honda Manual Transmission Fluid preferred, or an SAE 10W-30 or 10W-40 motor oil as a temporary replacement (see page [257](#)).

Capacity:

2.1 US qt (2.0 ℓ)

### **Power Steering Fluid:**

Honda Power Steering Fluid preferred, or another brand of power steering fluid as a temporary replacement. Do not use ATF (see page [260](#)).

### **Brake Fluid:**

Honda Heavy Duty Brake Fluid DOT 3 preferred, or a DOT 3 or DOT 4 brake fluid as a temporary replacement (see page [259](#)).

### **Tire Pressure (measured cold):**

Front:

32 psi (220 kPa , 2.2 kgf/cm<sup>2</sup>)

Rear:

30 psi (210 kPa , 2.1 kgf/cm<sup>2</sup>)