

Fuses

All the electrical circuits in your car have fuses to protect them from a short circuit or overload. These fuses are located in three fuse boxes.

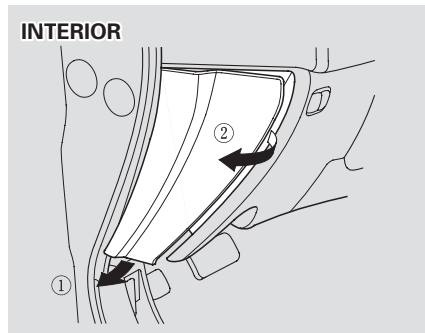

The interior fuse boxes are located on each side of the dashboard. To open an interior fuse box, open the car door. Pull the bottom of the cover open, then take it out of its side hinges by pulling it toward you.

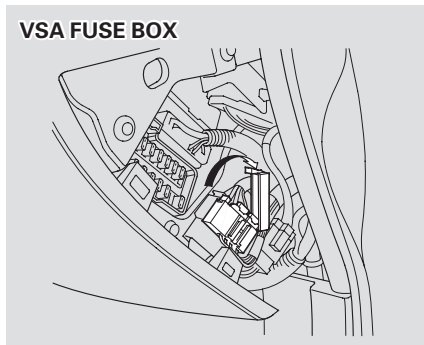

On Type-S with A/T
The VSA fuse box is located under the interior fuse box on the passenger's side of the dashboard. To open it, push the tab and pull up the left side of the cover as shown.

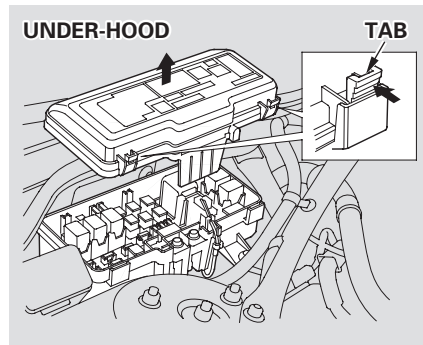

The under-hood fuse box is located in the back of the engine compartment on the passenger's side. To open it, push the tabs as shown.

Checking and Replacing Fuses

If something electrical in your car stops working, the first thing you should check for is a blown fuse. Determine from the chart on pages 317 – 319, or the diagram on the fuse box lid, which fuse or fuses control that component. Check those fuses first, but check all the fuses before deciding that a blown fuse is not the cause. Replace any blown fuses and check the component's operation.

1. Turn the ignition switch to LOCK (0). Make sure the headlights and all other accessories are off.
2. Remove the cover from the fuse box.

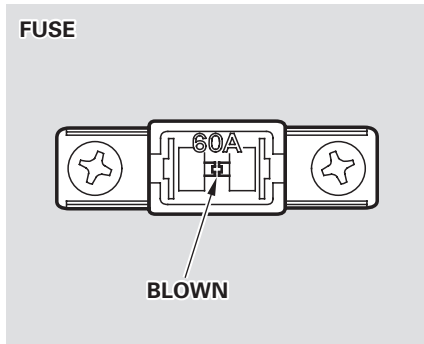

3. Check each of the large fuses in the under-hood fuse box by looking through the top at the wire inside. Removing these fuses requires a Phillips-head screwdriver.

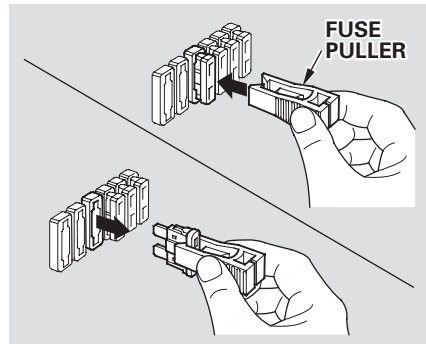

4. Check the smaller fuses in the under-hood fuse box and all the fuses in the interior fuse boxes by pulling out each fuse with the fuse puller provided in the under-hood fuse box.

CONTINUED

Fuses

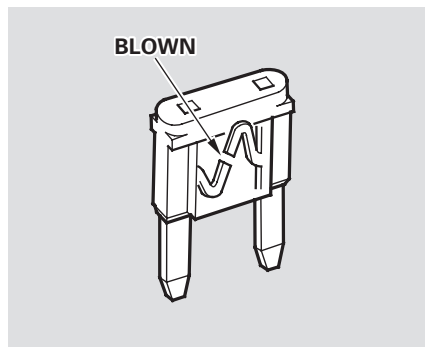

5. Look for a burned wire inside the fuse. If it is burned, replace it with one of the spare fuses of the same rating or lower.

If you cannot drive the car without fixing the problem, and you do not have a spare fuse, take a fuse of the same rating or a lower rating from one of the other circuits. Make sure you can do without that circuit temporarily (such as the accessory power socket or radio).

If you replace the blown fuse with a spare fuse that has a lower rating, it might blow out again. This does not indicate anything wrong. Replace the fuse with one of the correct rating as soon as you can.

NOTICE

Replacing a fuse with one that has a higher rating greatly increases the chances of damaging the electrical system. If you do not have a replacement fuse with the proper rating for the circuit, install one with a lower rating.

6. If the replacement fuse of the same rating blows in a short time, there is probably a serious electrical problem in your car. Leave the blown fuse in that circuit and have your car checked by a qualified mechanic.

If the radio fuse is removed, the audio system will disable itself. The next time you turn on the radio you will see “ [UdE] ” in the frequency display. Use the Preset buttons to enter the five-digit code (see page [157](#)).

UNDER-HOOD FUSE BOX

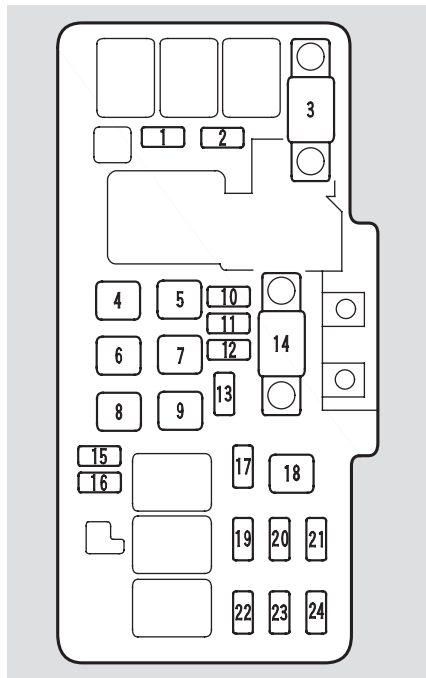

No.	Amps.	Circuits Protected
1* ¹	20 A	Condenser Fan
1* ²	30 A	Condenser Fan
2	7.5 A	MG Clutch
3	60 A	IG1 Main
4	40 A	Rear Window Defogger
5	40 A	Heater Motor
6* ¹	20 A	TCS
6* ²	40 A	VSA
6* ³	—	Not Used
7	40 A	Power Seat
8	40 A	Power Window Motor
9	40 A	Back Up, ACC
10	15 A	Spare Fuse
11	10 A	Spare Fuse
12	7.5 A	Spare Fuse

* 1 : Premium model

* 2 : Type-S with A/T

* 3 : Type-S with M/T

No.	Amps.	Circuits Protected
13* ^{1, *3}	20 A	Cooling Fan
13* ²	30 A	Cooling Fan
14	120 A	Battery
15	30 A	Spare Fuse
16	20 A	Spare Fuse
17	15 A	Hazard
18	30 A	ABS Motor
19	15 A	ACG S
20	20 A	Stop
21	20 A	ABS F/S Relay
22	20 A	Right Headlight
23	—	Not Used
24	20 A	Left Headlight

CONTINUED

Fuses

INTERIOR FUSE BOXES DRIVER'S SIDE

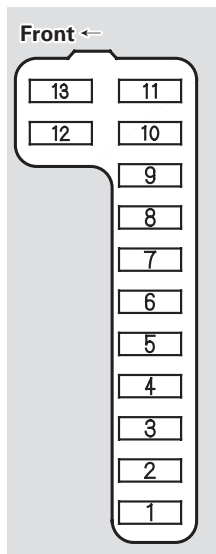

No.	Amps.	Circuits Protected
1	15 A	Fuel Pump
2	10 A	Main SRS
3	7.5 A	Heater Control, A/C Clutch Relay, Cooling Fan Relay
4	7.5 A	Mirror, Heated Seat, Heated Mirror
5	7.5 A	Daytime Running Lights*
6	15 A	ECU (PCM), Cruise Control, VSA
7	7.5 A	Side SRS
8	7.5 A	ACC Relay, Navigation
9	7.5 A	Instrument Panel, Back-up Lights, Memory Seat
10	7.5 A	Turn Signals
11	15 A	IG Coil
12	30 A	Wiper, Washer
13	7.5 A	Starter Signal

* : On Canadian models

PASSENGER'S SIDE

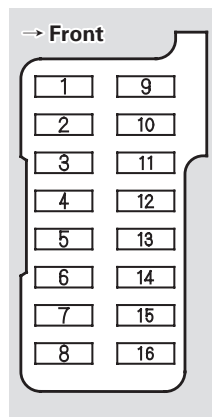

No.	Amps.	Circuits Protected
1	20 A	Left Power Window
2	20 A	Driver's Power Seat Reclining, Memory Seat
3	20 A	Heated Seat
4	20 A	Driver's Power Seat Sliding, Memory Seat
5	20 A	Passenger's Power Seat Sliding
6	20 A	Passenger's Power Seat Reclining
7	30 A	Moonroof Motor
8	20 A	Right Power Window
9	20 A	Radio, Power Outlet
10	10 A	Navigation System, Daytime Running Lights* ¹ OnStar* ²
11	7.5 A	Interior Light, Seat Memory, HomeLink
12	20 A	Power Door Locks
13	15 A	Clock, Back Up, Small Light
14	7.5 A	ABS Motor Check
15	–	Not Used
16	–	Not Used

* 1 : On Canadian models

* 2 : On cars with navigation system

VSA FUSE BOX

On Type-S with A/T

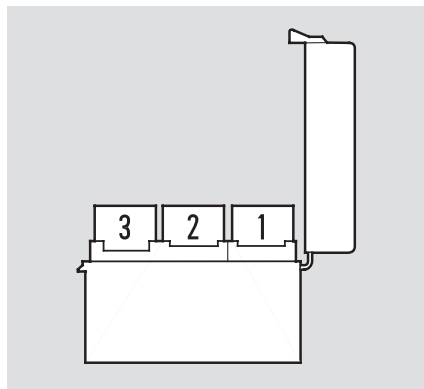

No.	Amps.	Circuits Protected
1	20 A	VSA F/S Relay
2	20 A	VSA Throttle Motor
3	—	Not Used