

Seats

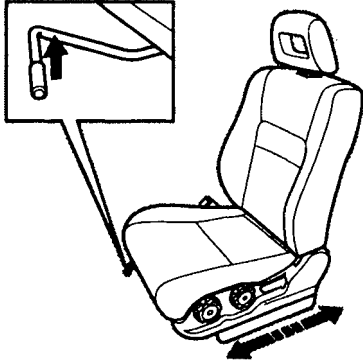

To adjust the seat forward and backward, pull up on the lever under the seat cushion's front edge. Move the seat to the desired position and release the lever. Try to move the seat to make sure it is locked in position.

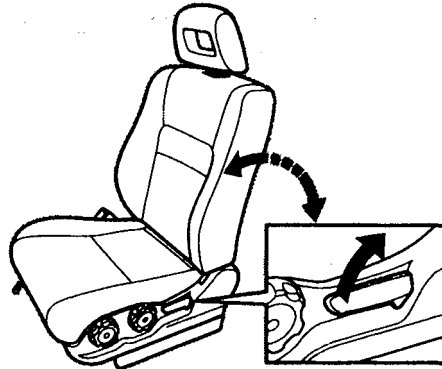

To change the angle of the seat-back, pull up on the lever on the outside of the seat bottom. Move the seat-back to the desired position and release the lever. Let the seat-back latch in the new position.

Driver's Seat Height Adjustment

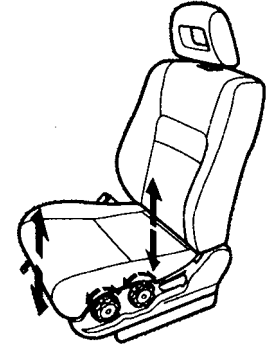

The height of your driver's seat is adjustable. Turn the front dial on the outside of the seat cushion to raise the front of the seat bottom and turn the rear dial to raise the rear.

Make all seat adjustments before you start driving.

Head Restraints

See page 14 for important safety information and a warning about how to properly position the head restraints. The head restraints help protect you and your passengers from whiplash and other injuries. They are most effective when you adjust them so the back of the occupant's head rests against the center of the restraint. A taller person should adjust the restraint as high as possible.

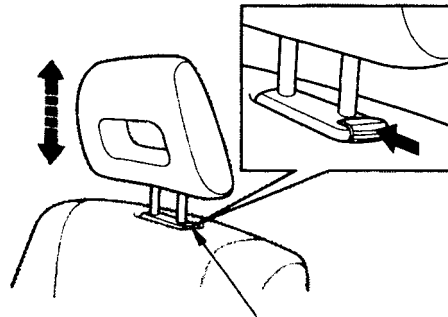

RELEASE BUTTON

The head restraints adjust for height. You need both hands to adjust the restraint. Do not attempt to adjust it while driving. To raise it, pull upward. To lower the restraint, push the release button sideways and push the restraint down.

To remove a head restraint for cleaning or repair, pull it up as far as it will go. Push the release button and pull the restraint out of the seat-back.

Seats

Rear Seat-back Adjustment

See pages 12 — 14 for important safety information and warnings about how to properly position seats and seat-backs.

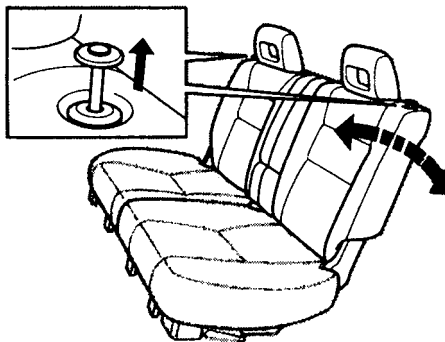

The angle of the rear seat-backs can be adjusted separately. To change the angle of the seat-back, pull up on the knob on the top of the seat-back. Move the seat-back to the desired position, then release the knob. Make sure the seat-back latches in the new position.

Rear Seat Armrest

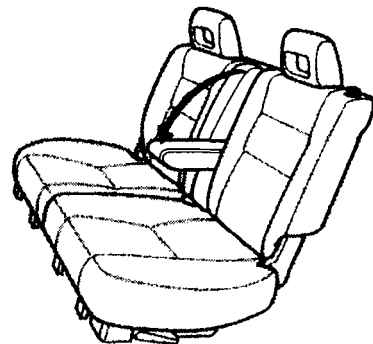

The rear seat armrest is located at the center of the rear seat. Pivot it down to use it.

Reclining the Front and Rear Seat-backs

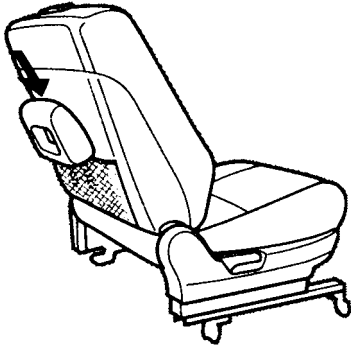

You can recline the seat-backs on the front and rear seats to make a large cushioned area. To do this:

1. Remove the front seat head restraint and put it in the pocket of the seat-back.

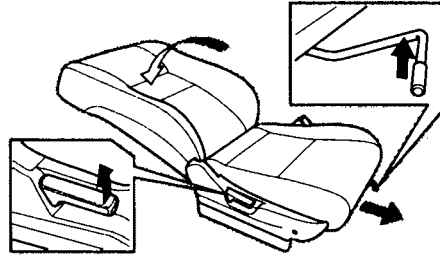

2. Lift the lever and slide the front seat forward as far as it will go. Pull up the seat-back angle adjustment lever, then pivot the seat-back backward. Release the lever when the seat-back is even with the cushion on the rear seat.

EX model

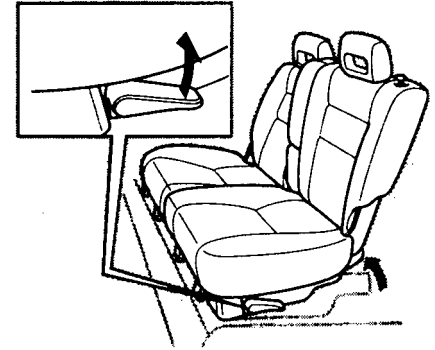

3. Pull up the lever on the side of the rear seat. Lift the rear edge of the seat bottom until the seat latches.

CONTINUED

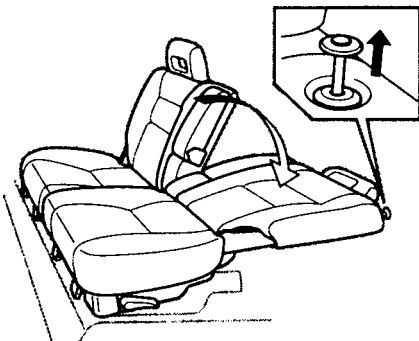

4. Pull up on the knob on top of the seat-back and pivot the rear seat-back backward. Release the knob when the seat-back is reclined as far as it will go.

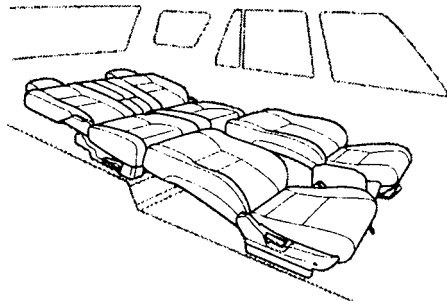

Reverse this procedure to return the seats to their upright positions. Make sure you install the head restraints, and that the seats are locked securely in place before driving.

Folding Rear Seat

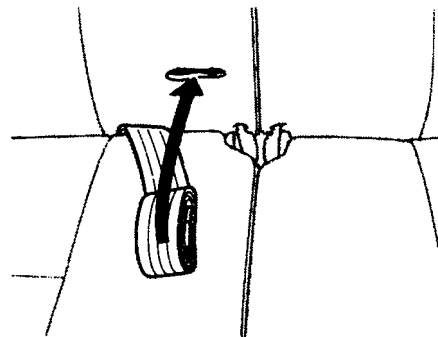

The left and right halves of the rear seat can be folded up separately to create more cargo space.

1. Store the latch plate for the center lap belt by rolling up the belt and pushing it into the seat pocket.

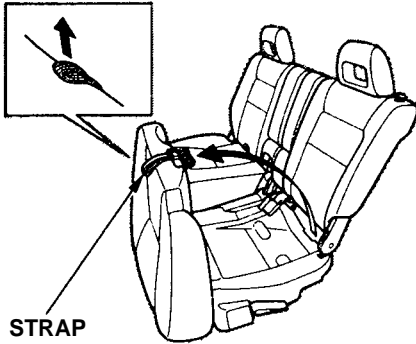

2. Pull the strap to release the seat bottom. Pivot the seat bottom forward.

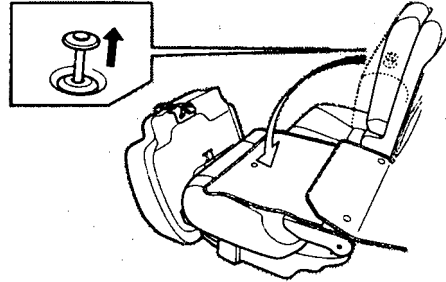

3. Remove the head restraint and pull up on the knob on the top of the seat-back. Pivot the seat-back forward.

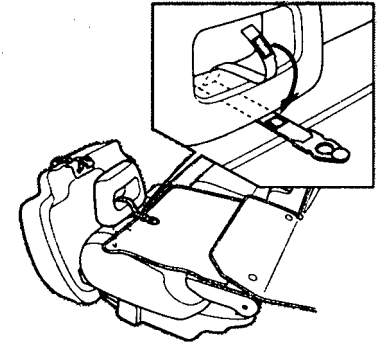

Put the head restraint behind the seat bottom as shown. Pass the fastening strap in through the hole of head restraint and fasten it with the Velcro strap.

Reverse this procedure to return the seat to the upright position. Make sure that the seat is locked securely before driving.

CONTINUED

Seats, Power Windows

Make sure any items stored in the cargo area are secured. Loose items can fly forward and cause injury if you have to brake hard.

Power Windows

Your vehicle's windows are electrically-powered. Turn the ignition switch to ON (II) to raise or lower any window.

Each door has a switch that controls its window. To open the window, push the switch down and hold it. Release the switch when you want the window to stop. Close the window by pushing the switch up and holding it.

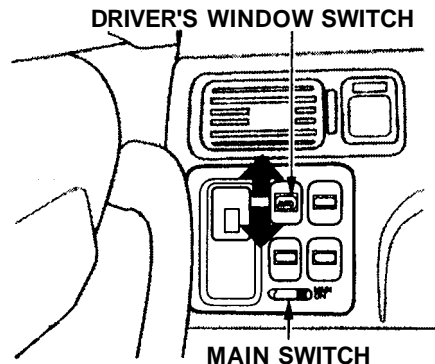

There is a master power window control panel on the dashboard. To open any of the passengers' windows, push down on the appropriate switch and hold it down until the window reaches the desired position. To close the window, push up on the window switch. Release the switch when the window gets to the position you want.

⚠ WARNING

Closing a power window on a child's hands or fingers can cause serious injury.

Make sure your children are away from the windows before closing them.

The AUTO function only works to lower the driver's window. To raise the window, you must push the window switch up and hold it until the window reaches the desired position.

The MAIN switch controls power to the passengers' windows. With this switch off, the passengers' windows cannot be raised or lowered. The MAIN switch does not affect the driver's window. Keep the MAIN switch off when you have children in the vehicle so they do not injure themselves by operating the windows unintentionally.

The master control panel also contains these extra features:

AUTO — To open the driver's window fully, push the window switch firmly down and release it. The window automatically goes all the way down. To stop the window from going all the way down, push the window switch up briefly. To open the driver's window only partially, push the window switch down lightly and hold it. The window will stop as soon as you release the switch.

Mirrors

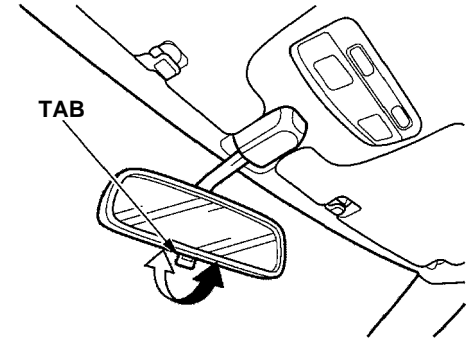

Keep the inside and outside mirrors clean and adjusted for best visibility. Be sure to adjust the mirrors before you start driving.

The inside mirror has day and night positions. The night position reduces glare from headlights behind you. Flip the tab on the bottom edge of the mirror to select the day or night position.

CONTINUED

Mirrors, Parking Brake

Adjusting the Power Mirrors

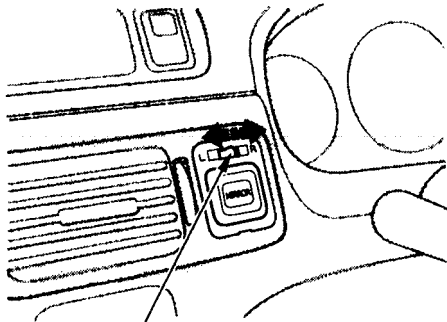

SELECTOR SWITCH

Adjust the outside mirrors with the adjustment switch on the left side of the dashboard:

1. Turn the ignition switch ON (II).
2. Move the selector switch to L (driver's side) or R (passenger's side).

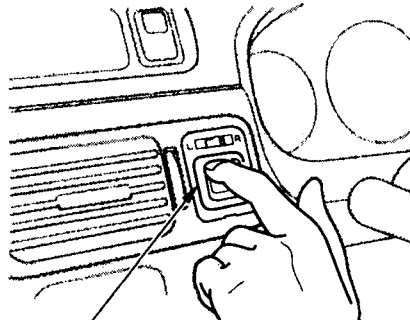

ADJUSTMENT SWITCH

3. Push the appropriate edge of the adjustment switch to move the mirror right, left, up or down.
4. When you finish, move the selector switch to the center (off) position. This turns off the adjustment switch so you can't move a mirror out of position by accidentally bumping the switch.

Parking Brake

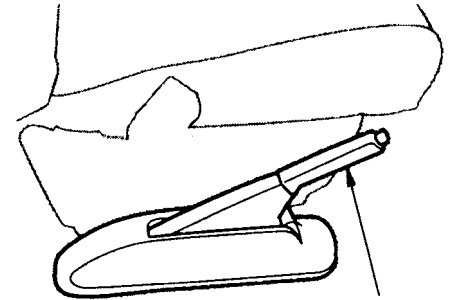

PARKING BRAKE LEVER

To apply the parking brake, pull the lever up fully. To release it, pull up slightly, push the button, and lower the lever. The parking brake light on the instrument panel should go out when the parking brake is fully released (see page 54).

NOTICE

Driving the vehicle with the parking brake applied can damage the rear brakes and axles.

Digital Clock

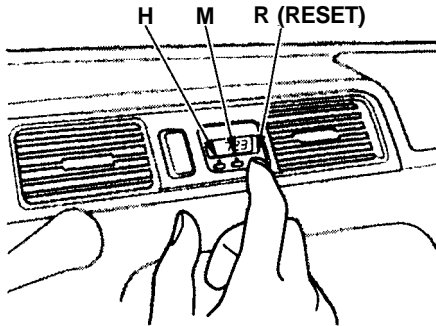

The digital clock displays the time with the ignition switch ON (II). To set the clock:

1. Turn the ignition switch ON (II) to display the time.
2. Press and hold the H button until the hour advances to the desired hour.

3. Press and hold the M button until the numbers advance to the desired minutes.

You can use the RESET button to quickly set the time to the nearest hour. If the displayed time is before the half hour, pressing RESET button sets the clock back to the previous hour. If the displayed time is after the half hour, pressing the RESET button sets the clock forward to the beginning of the next hour.

For example:

- 1:06 would RESET to 1:00.
- 1:52 would RESET to 2:00.

Center Table

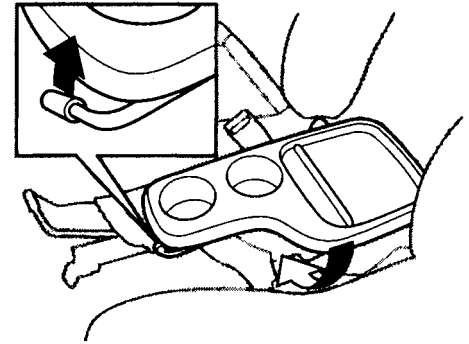

To use the center table, pull up the outside edge of the table until it latches. To store it, pull the lever and lower the table.

CONTINUED

Center Table, Beverage Holder

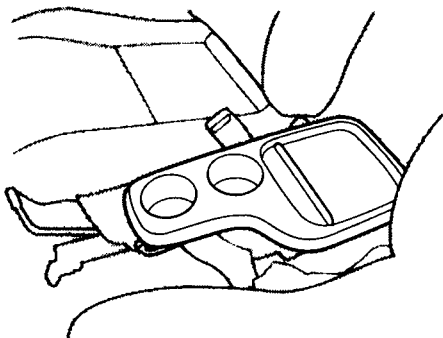

Sitting on or getting under the table, or putting heavy objects on the table, may damage or deform it.

Do not put any items on the table while driving. They may fall down or fly around when you go around corners or brake hard.

Beverage Holder

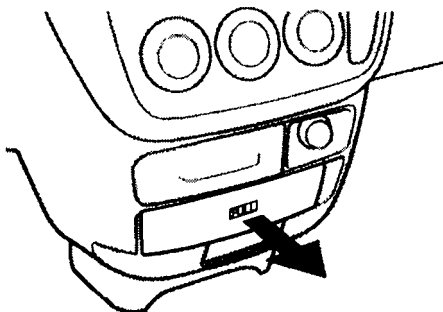

Automatic Transmission model only
To use the beverage holder, pull on the front. Push the holder all the way in to close it.

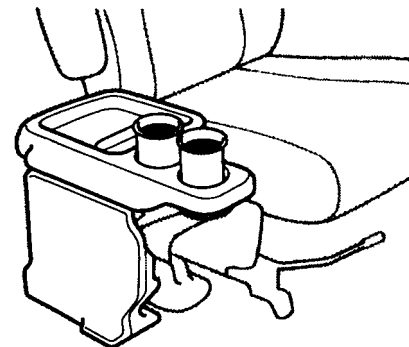

The center table also has a beverage holder.