

## Closing the Sunroof

If the electric motor will not close the sunroof, do the following:

1. Check the fuse for the sunroof motor (see page 198). If the fuse is blown, replace it with one of the same or lower rating.
2. Try closing the sunroof. If the new fuse blows immediately or the sunroof motor still does not operate, you can close the sunroof manually.
3. Get the tool kit out of the trunk.

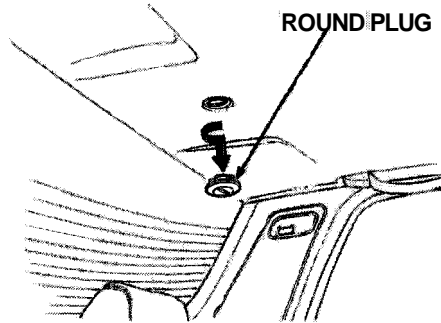

4. Use a screwdriver or coin to remove the round plug in the center of the headliner.

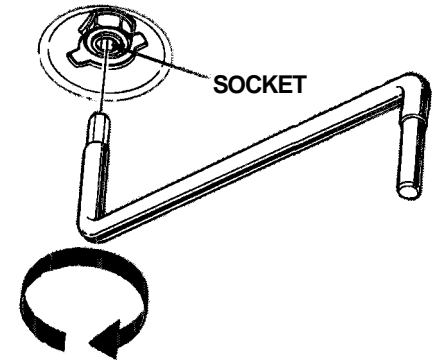

5. Insert the sunroof wrench into the socket behind this plug. Turn the wrench until the sunroof is fully closed.
6. Remove the wrench. Replace the round plug.

## Fuses

All the electrical circuits in your car have fuses to protect them from a short circuit or overload. These fuses are located in two fuse boxes.

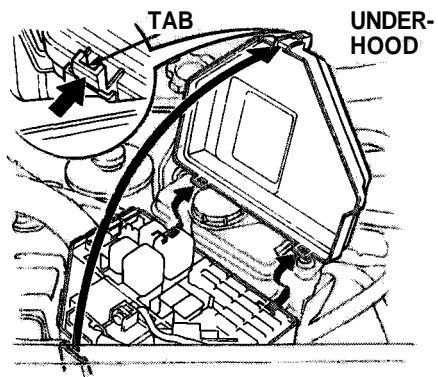

The underhood fuse box is located in the front of the engine compartment on the passenger's side. To open, push the tab as shown.

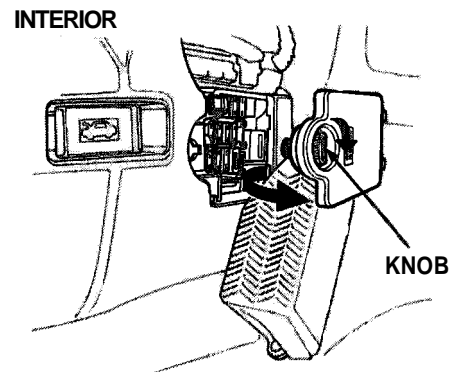

The interior fuse box is underneath the dashboard on the driver's side. To open, turn the knob as shown.

## Checking and Replacing Fuses

If something electrical in your car stops working, the first thing you should check for is a blown fuse. Determine from the chart on the fuse box cover or inside the fuse box which fuse or fuses control that component. Check those fuses first, but check all the fuses before deciding that is not the cause. Replace any blown fuses and check the component's operation.

1. Turn the ignition switch to LOCK (0). Make sure the headlights and all other accessories are off.
2. Remove the cover from the fuse box.

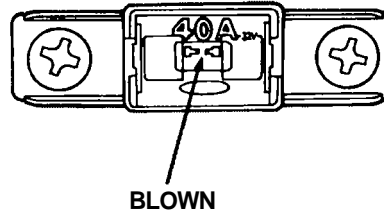

3. Check each of the large fuses in the underhood fuse box by looking through the top at the wire inside. Removing these fuses requires a phillips head screwdriver.

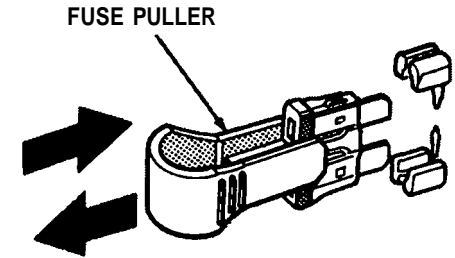

4. Check the smaller fuses in the underhood fuse box and all the fuses in the interior fuse box by pulling out each fuse with the fuse puller provided in the interior fuse box.

CONTINUED

# Fuses

---

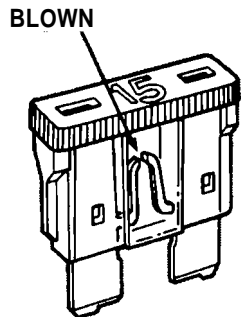

5. Look for a burned wire inside the fuse. If it is burned out, replace it with one of the spare fuses of the same rating or lower.

If you cannot drive the car without fixing the problem, and you do not have a spare fuse, take a fuse of the same rating or a lower rating from one of the other circuits. Make sure you can do without that circuit temporarily (such as the rear window defogger, or radio). If you replace the burned out fuse with a spare fuse that has a lower rating, it might blow out again. This does not indicate anything wrong. Replace the fuse with one of the correct rating as soon as you can.

## NOTICE

Replacing a fuse with one that has a higher rating greatly increases the chances of damaging the electrical system. If you do not have a replacement fuse with the proper rating for the circuit, install one with a lower rating.

6. If the replacement fuse of the same rating burns out in a short time, there is probably a serious electrical problem in your car. Leave the burned out fuse in that circuit and have your car checked by a qualified technician.

If your car needs to be towed, call a professional towing service or, if you belong to one, an organization that provides roadside assistance. Never tow your car behind another car with just a rope or chain. It is very dangerous.

## Emergency Towing

There are three popular methods of towing a car:

**Flat-bed Equipment** — The operator loads your car on the back of a truck. **This is the best way of transporting your Acura.**

**Wheel Lift Equipment** — The tow truck uses two pivoting arms which go under the tires (front or rear) and lift them off the ground. The other two wheels remain on the ground.

**Sling-type Equipment** — The tow truck uses metal cables with hooks on the ends. These hooks go around parts of the frame or suspension and the cables lift that end of the car off the ground. Your car's suspension and body can be seriously damaged if this method of towing is attempted.

If your Acura cannot be transported by flat-bed, it should be towed with the front wheels off the ground. If due to damage, your car must be towed with the front wheels on the ground, do the following:

- Release the parking brake.
- Shift the transmission to Neutral (5-speed). If your car has an automatic transmission: Start the engine. Shift to D<sub>4</sub>, then to Neutral. Shut the engine off.

## NOTICE

Improper towing preparation will damage the transmission. Follow the above procedure exactly. If you cannot shift the transmission or start the engine (automatic transmission), your car must be transported on a flat-bed.

- It is best to tow the car no farther than 50 miles (80 km), and keep the speed below 35 mph (55 km/h).

## NOTICE

Trying to lift or tow your car by the bumpers will cause serious damage. The bumpers are not designed to support the car's weight.