

2026 Passport Series: Body Repair Information

APPLIES TO

Year	Model	Available Trims	
2026	Passport	RTL	RTL Towing
		RTL Blackout	TrailSport
		TrailSport Blackout	TrailSport Elite
		TrailSport Elite-Blackout	

INTRODUCTION

This publication contains a summary of new body and vehicle technologies that may affect collision and other body repairs. Always refer to the service information and body repair manual (BRM) for complete repair information. A subscription may be purchased at [Service Express](#).

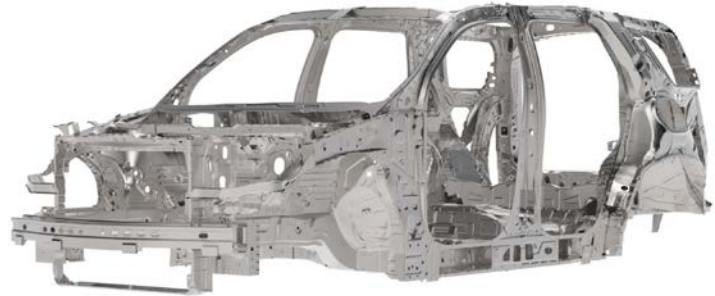

AVAILABLE COLORS

Code	Color	Code	Color
NH-797M	Modern Steel Metallic	YR-585	Sunset Orange
NH-731P	Crystal Black Pearl	G-545M	Ash Green Metallic II
B-588PX	Obsidian Blue Pearl	R-580M	Radiant Red Metallic
NH-883P	Platinum White Pearl	NH-877P	Sonic Grey Pearl

BODY CONSTRUCTION AND HIGH STRENGTH STEEL CONTENT

- Steel parts are color coded based on their tensile strength in megapascals (MPa).
- High-strength steel (HSS) is defined as any steel with a tensile strength of **340 MPa** or higher.
- Ultra-high-strength steel (UHSS) is defined as any steel with a tensile strength of **980 MPa** or higher.
- Steel repair and welding procedures vary depending on the tensile strength of the parts involved.

NOTE: The illustrations on the next page are for general reference only. Some body parts are constructed from multiple layers of different tensile-strength steels. Always refer to the body construction section of the BRM for specific steel tensile-strength information.

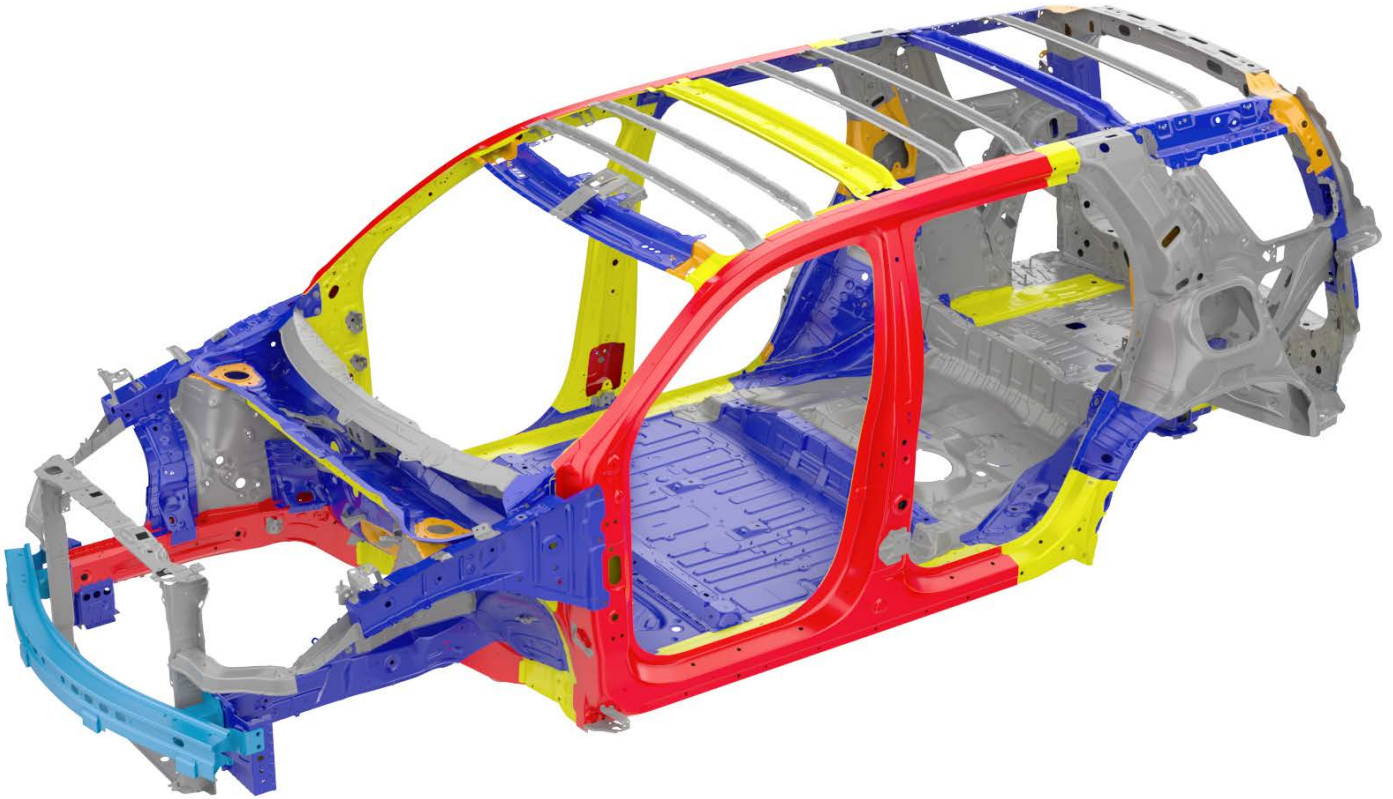

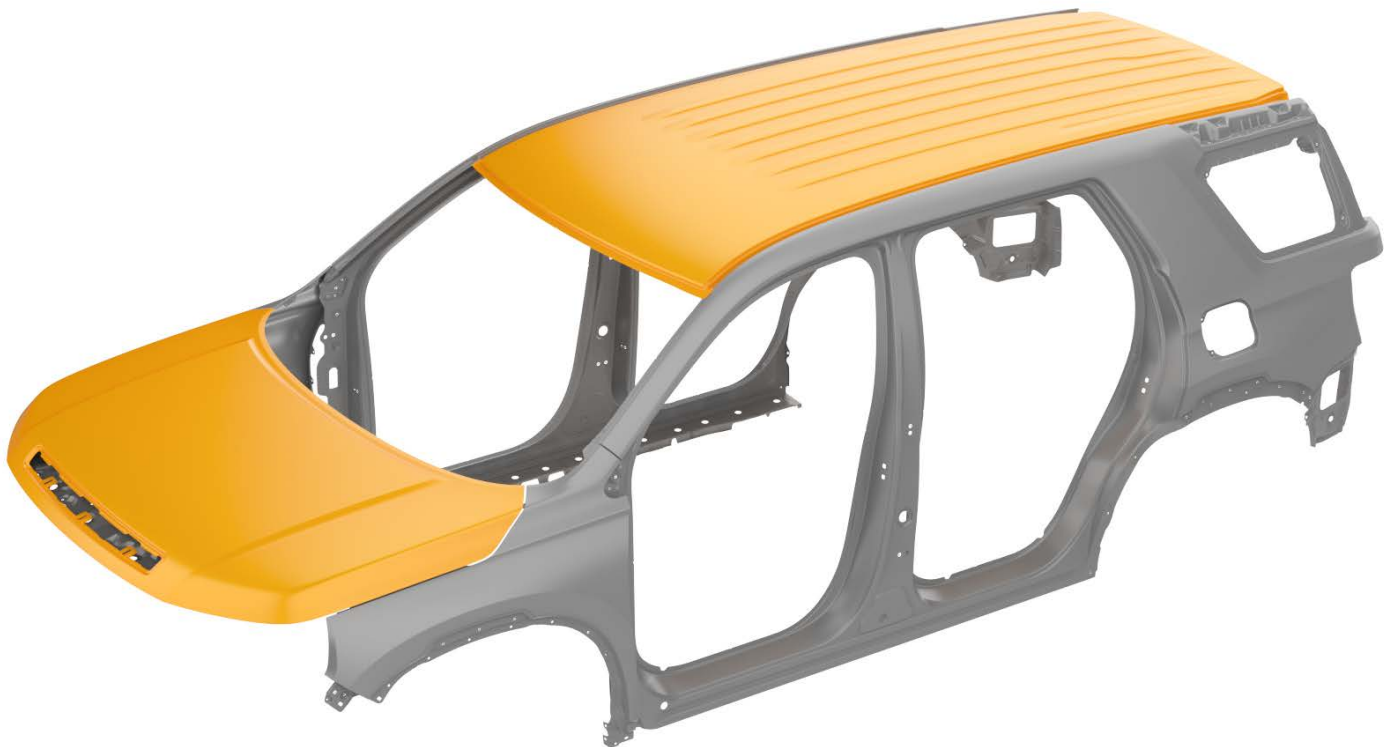
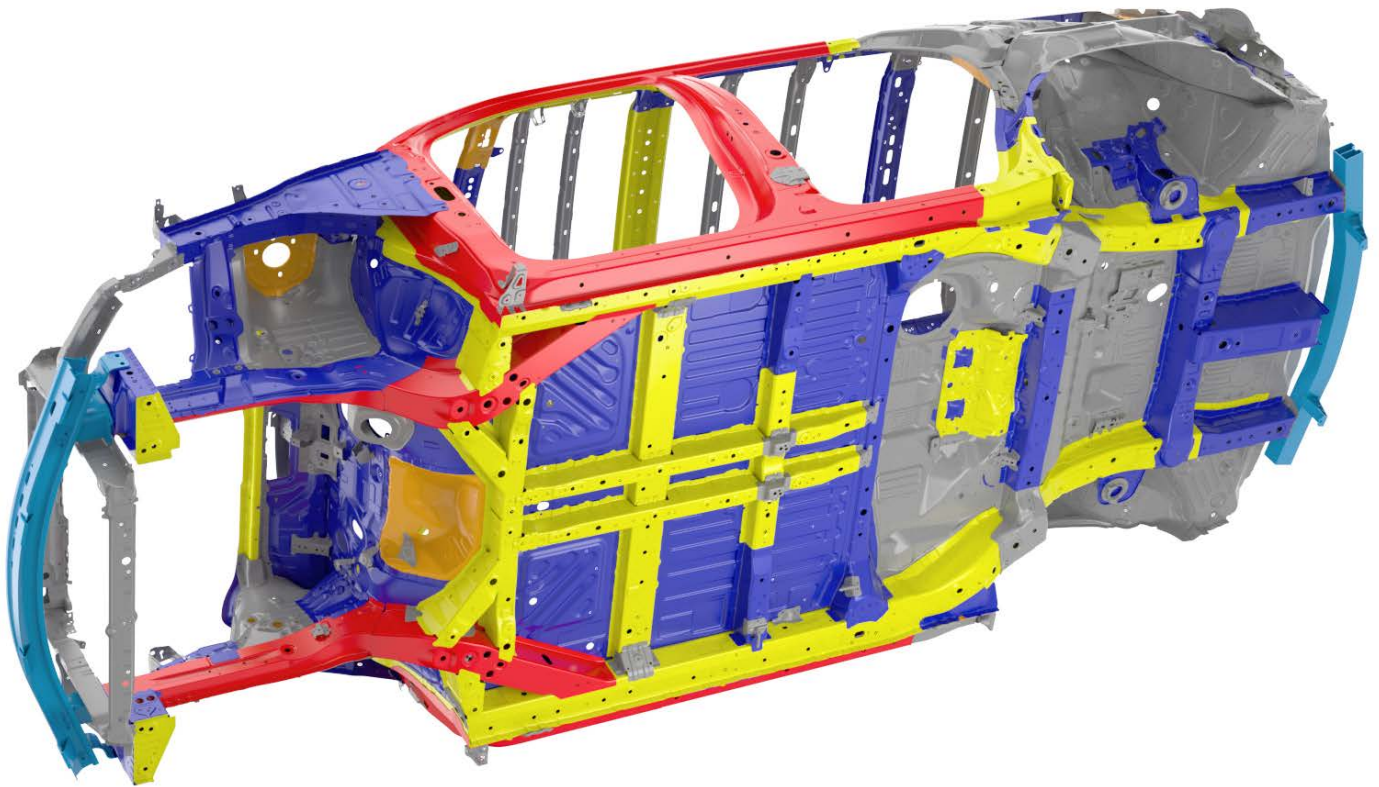

ACOUSTIC FOAM & INSULATORS

Accoustic Foam Locations



Melt Sheets

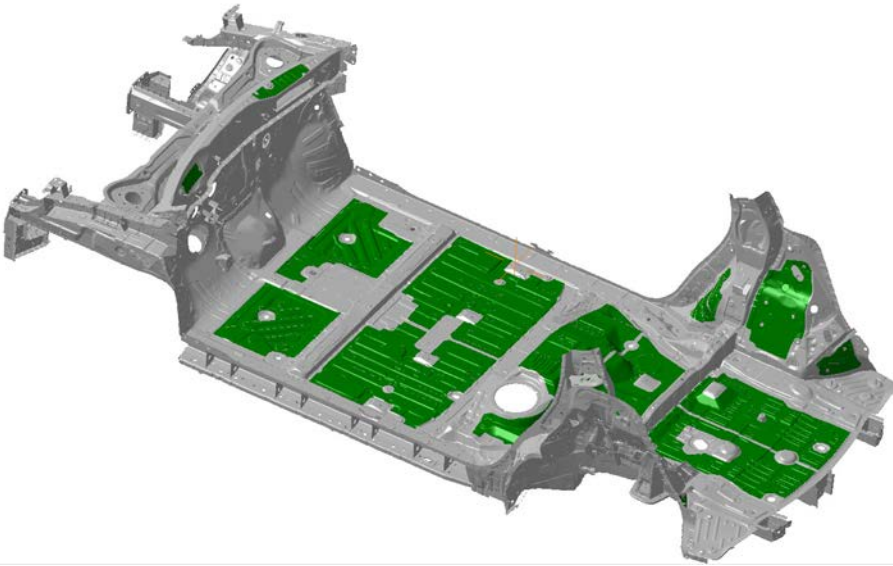

Insulation

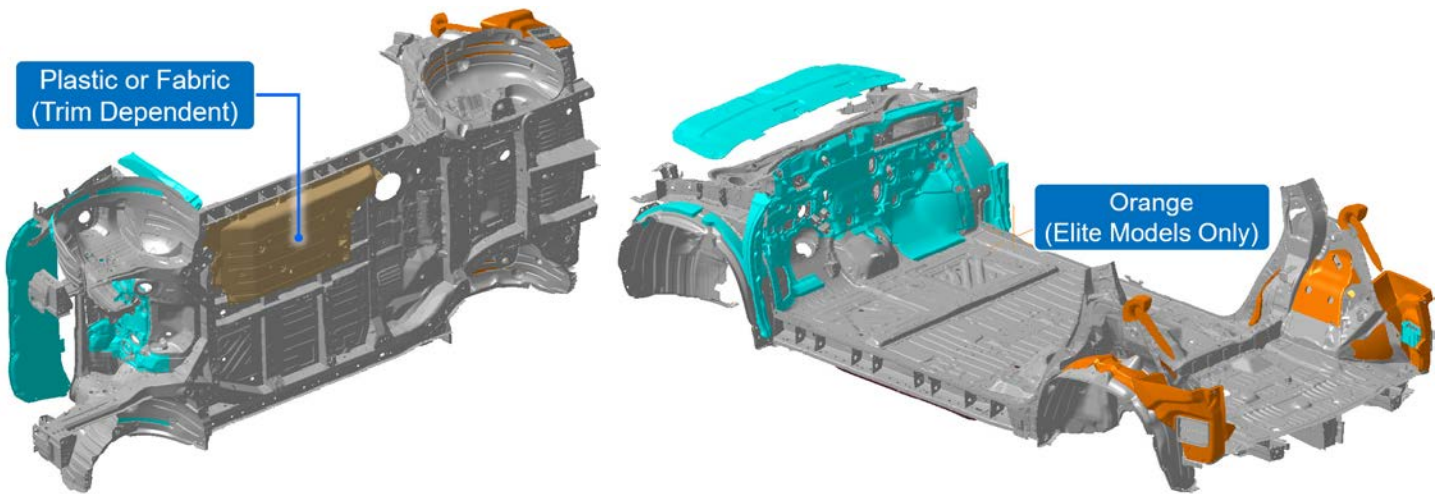

FRONT BUMPER BEAM REMOVAL & INSTALLATION

The front bulkhead is supported by the front bumper beam.

NOTE:

- Before removing the beam, make sure to support the front bulkhead.
- After installation, make sure to confirm proper fit and finish.

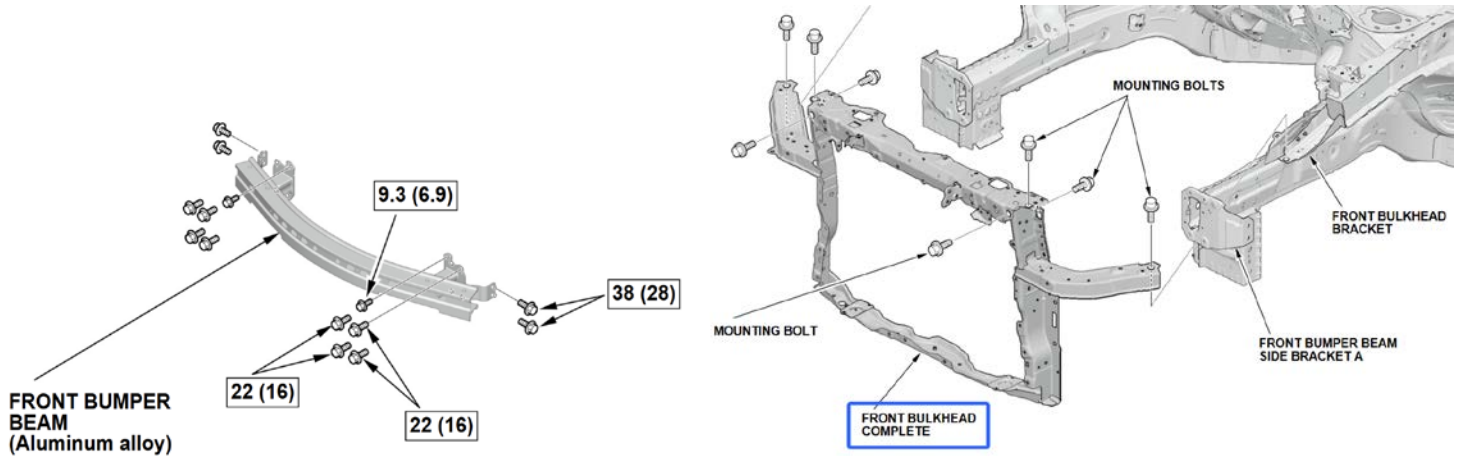

OPENING HOOD (SERVICE MODE)

It may be necessary to open the hood further than the standard 45° . To further open the hood ($\sim 77^\circ$), disconnect the hood support strut from the pivot ball (mounted on hood), raise the hood and reinstall the strut on to the service pivot ball. Do this for both sides. Refer to the **Hood Area** of the service manual for additional details.

NOTICE: Never attempt to close the hood with the support strut in the vertical position, as it will damage the support strut and hood.

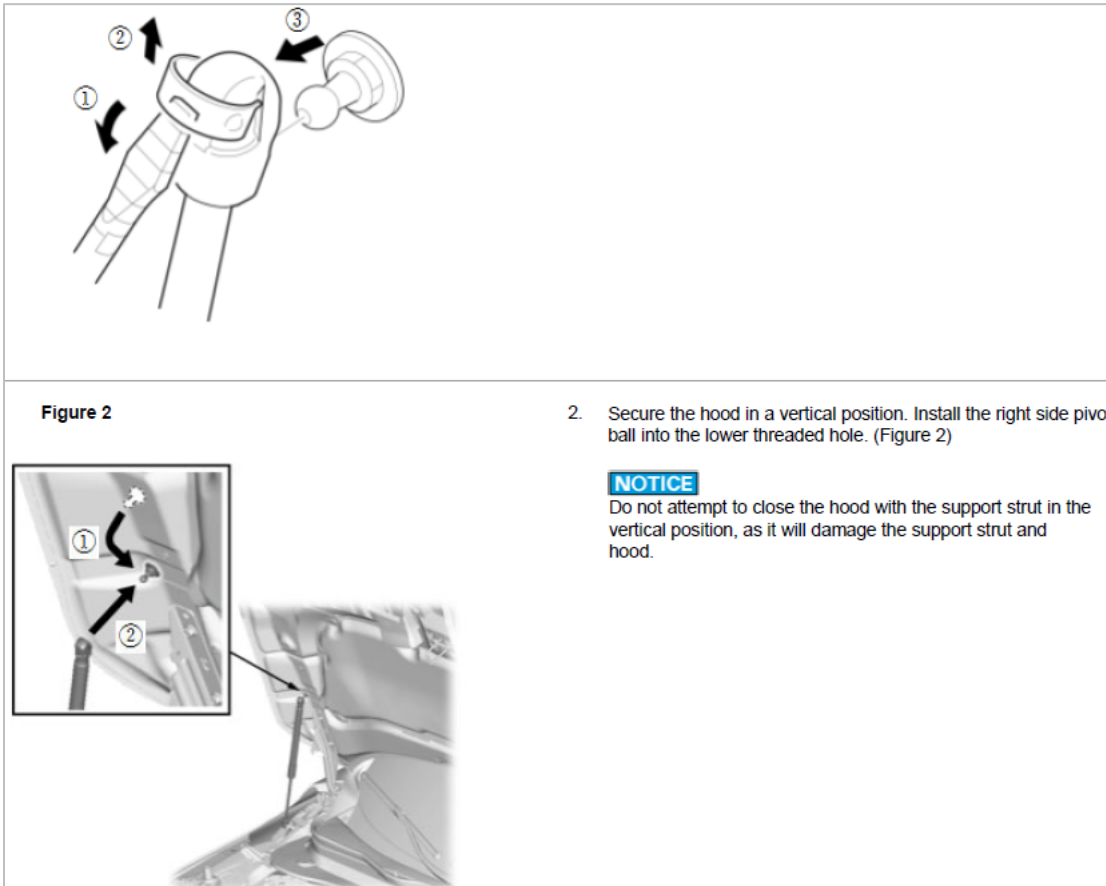

REMOVING & INSTALLING THE HEADLINER

To prevent damage to a headliner that will be reinstalled, make sure to have two assistants assist during the removal and installation process. Have one technician on each side and one at the rear (removal) or the front (installation) of the headliner.

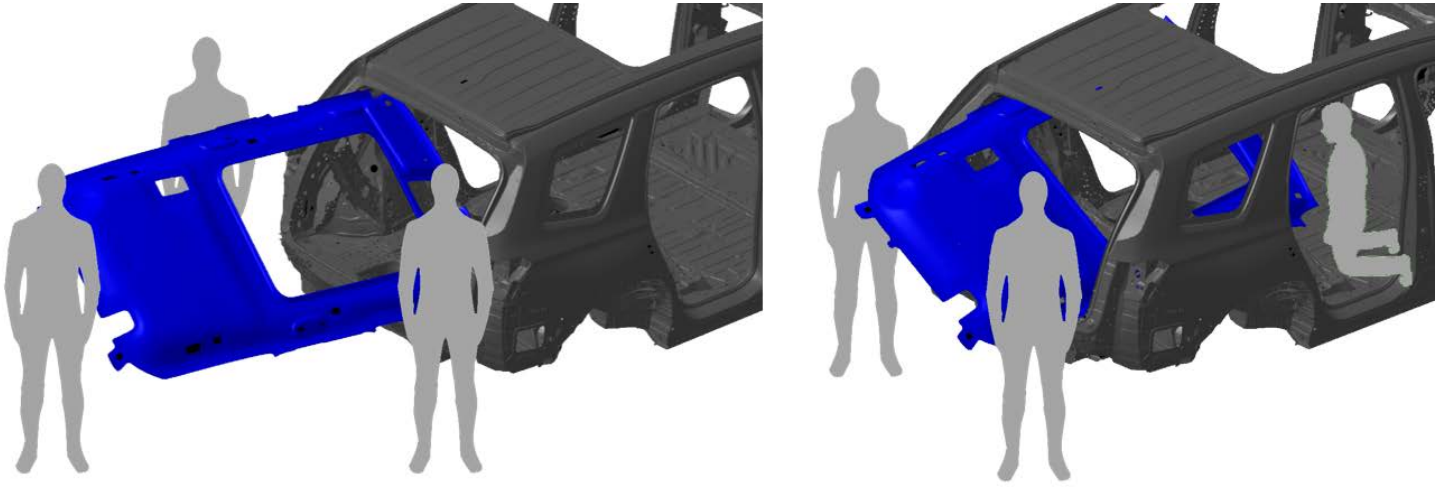

DRIVING SUPPORT

Features

The Passport is equipped with the following driving support features:

Adaptive Cruise Control (ACC) with Low Speed Follow
Lane Keeping Assist System (LKAS)
Traffic Jam Assist (TJA)
Low Speed Braking Control (LsAEB)
Collision Mitigation Braking System (CMBS)
Road Departure Mitigation System (RDM)
Traffic Sign Recognition (TSR)
Blind Spot Information (BSI)

Blind Spot Information (BSI)

Similar to the 2023 series Pilot model, the conventional blind spot information (BSI) radar unit inspection procedure is not required. The system is capable of self-learning while the vehicle is being driven above certain speeds.

Remember these key points:

- If the original BSI radar unit is removed and reinstalled, you must do the *Blind Spot Information (BSI) System Learning Value Reset*.
- If you install a new BSI radar unit, the learning value reset is not required.
- When the learning value is reset, the detection range returns to **10 feet**, and the detection range is not expanded until the automatic learning is completed.
- Make sure to review the *Precautions for Handling Bumper* prior to any repairs and painting.