

MODEL/YEAR MODÈLE /ANNÉE	DATE OF ISSUE DATE EN VIGUEUR	BULLETIN NUMBER NUMÉRO DU BULLETIN
2013-2015 RDX	AUG. 22, 2014	BRN-14-4

## 2013-2015 RDX: New Model Body Repair Information

**DISCLAIMER:** This publication contains a summary of new body and vehicle technology that may affect collision and other body repairs. Always refer to the appropriate service and body repair manuals for complete repair information. A subscription may be purchased at: [techinfo.acura.com](http://techinfo.acura.com)

### TABLE OF CONTENTS

New Model Body Technology	Page 2
Body Repair Information	Page 4
Welding Precautions and Information	Page 5
Airbag System Components and Repairs	Page 7
Electrical Repair Information	Page 9

### OVERVIEW OF BODY FEATURES

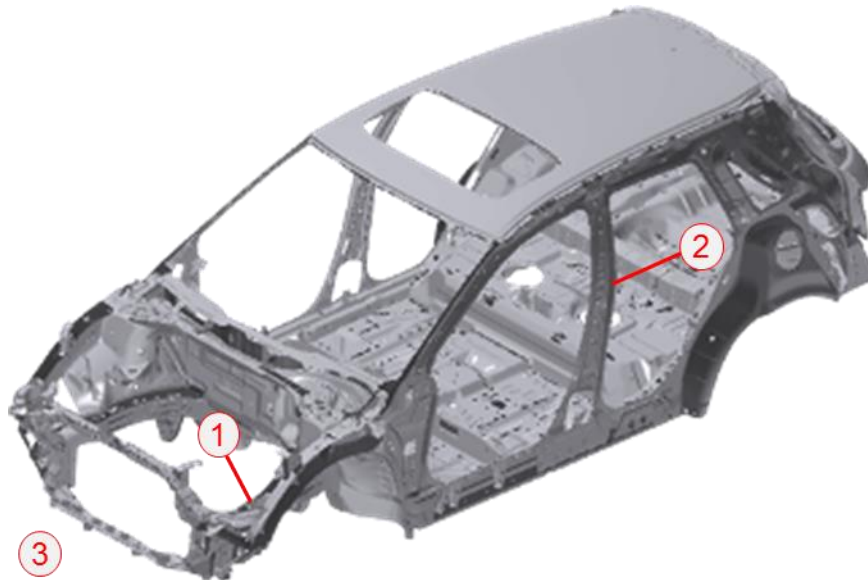

1. Advanced Compatibility Engineering™ (ACE™) body structure.
2. Body construction using 56% high tensile strength steel, including 25% in grades 780, and 1,500 MPa.
3. Aluminum hood panel and front bumper beam for weight reduction and improved fuel efficiency (not shown in this view).

# New Model Body Technology

## BODY CONSTRUCTION AND HIGH STRENGTH STEEL CONTENT

- Steel parts are color-coded based on their tensile strength in megapascals (MPa).
- High strength steel is defined as any steel with a tensile strength of 340 MPa or higher.
- Steel repair and welding procedures vary depending on the tensile strength of the parts involved.
- The door and rear bumper reinforcement beams are also made from high-strength steel.

270 MPa
440 MPa
590 MPa
780 MPa
1,500 MPa

Steel Tensile Strength Legend

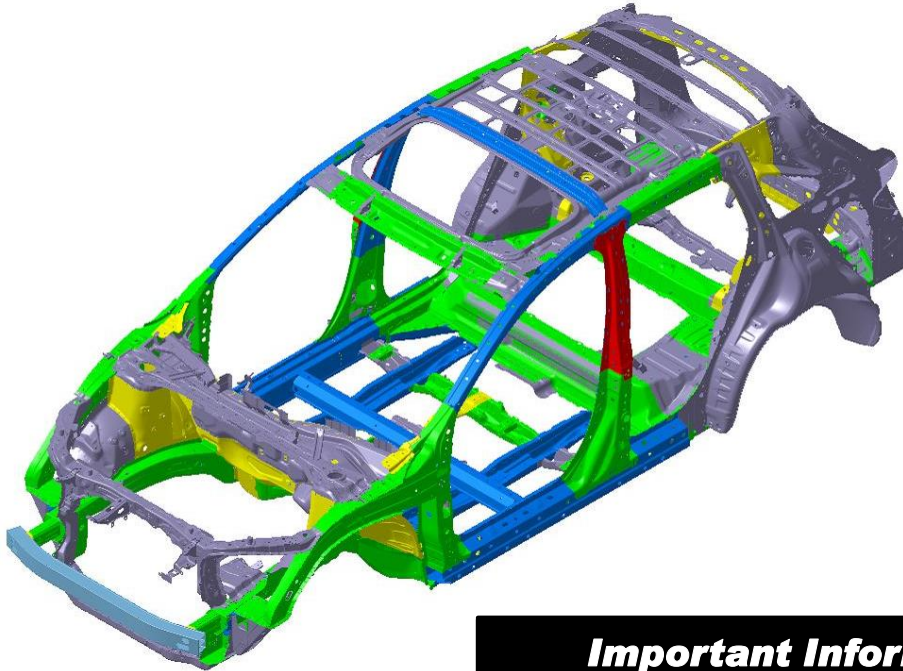

### **Important Information**

These illustrations are for general reference only. Some body parts are constructed from multiple layers of different tensile strength steels. Always refer to the body repair manual body construction section for specific steel tensile strength information.

### **1,500 MPa (HOT STAMP) STEEL LOCATIONS**

1,500 MPa steel is stronger than ordinary steel, so it can help protect vehicle occupants while reducing overall vehicle weight to improve fuel efficiency.

The numbered part in the diagram shown here is constructed of 1,500 MPa steel:

All Models	
1	Center Pillar Upper Stiffener (Both Sides)

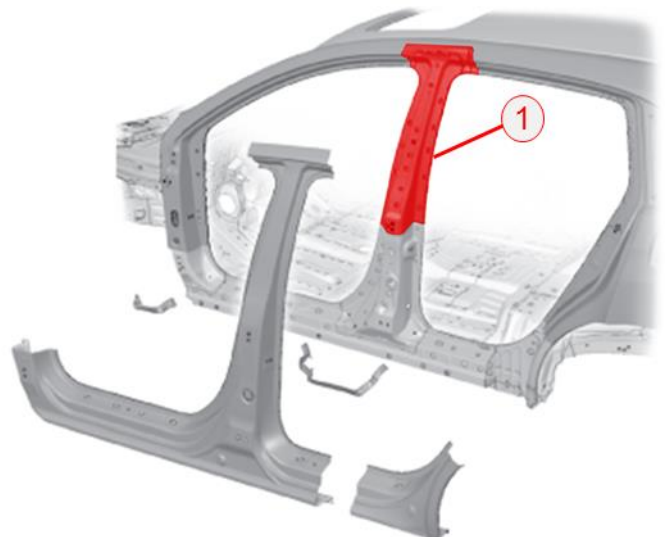

## ALUMINUM PARTS & REPAIRABILITY

The hood panel and front bumper beam are constructed of aluminum alloy.

### Repairability Issues:

- Do not repair damaged bumper beams.
- The aluminum hood may be repaired by body shops that have a dedicated aluminum repair facility and separate tools.
- To prevent galvanic corrosion, some fasteners for aluminum parts are considered one-time use and must be replaced if removed. Refer to the service or body repair manual for more information.

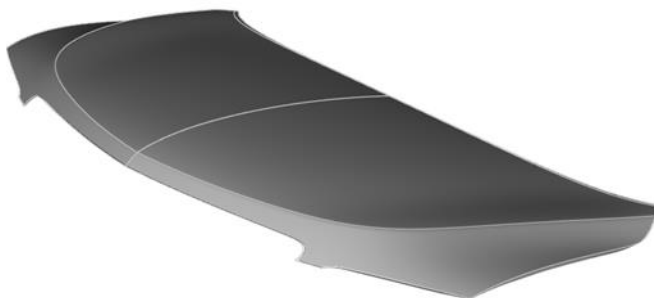

Hood Panel

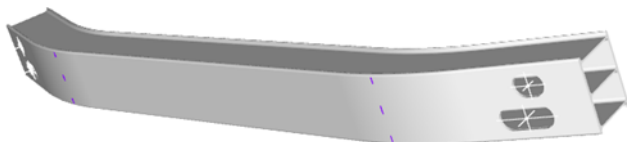

Front Bumper Beam

## TOWING AND LIFTING PRECAUTIONS

- All Canadian-spec RDX are AWD, and must be towed using flat bed towing equipment only to prevent AWD system damage.
- AWD models do not have a manual switch to disable the system. Whenever service work requires spinning the front or rear wheels with the engine, always lift and support the vehicle so all four wheels are off the ground.

For more information, refer to “Emergency Towing” in the owner’s manual.

- Lift or jack only at the specified points to avoid damaging the vehicle.
- Do not lift or tow this vehicle by its bumpers, or serious damage will result.

For more information, refer to “Lift and Support Points” in the appropriate service or body repair manual.

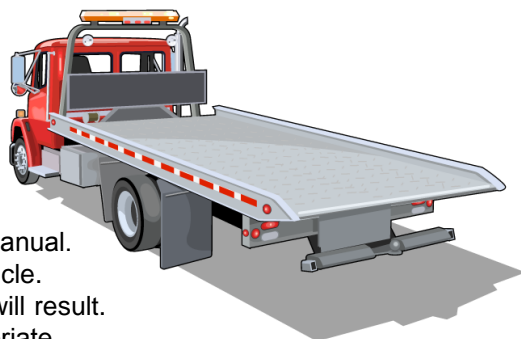

# Body Repair Information

NOTE: The following content is intended only to highlight new/special concerns. No body repairs should be attempted without first referencing the appropriate body repair manual for complete information.

## USE OF HEAT DURING BODY STRAIGHTENING AND REPAIR

When you are doing body straightening and repair procedures:

- DO NOT apply heat to any body part during straightening. This may compromise the internal structure and strength of high-strength steel parts.
- Any part that has heat applied to it during straightening MUST be replaced with new parts.
- Ignoring these instructions may significantly reduce occupant protection in any subsequent collision.

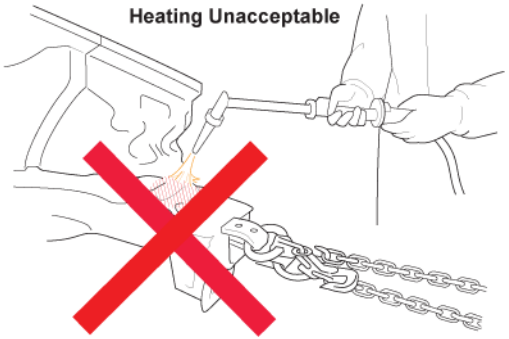

## SECTIONING (CUT AND JOINT) GUIDELINES

Because of body structure improvements for collision safety and rigidity, the materials, steel thickness, and internal reinforcements have become very specific.

Follow these guidelines to avoid an unsafe repair:

- Avoid sectioning (cut and joint) except for outer panels and floor panels unless a specific procedure is provided in the body repair manual.
- Replace body structural components as assemblies that match the replacement parts configuration.
- Refer to "Front Side Frame and Rear Frame Cutting and Splicing" in the body repair manual for sectioning opportunities.

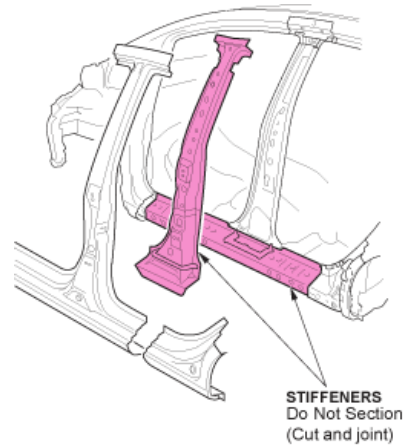

# Welding Precautions and Information

## REPAIRING 1,500 MPa STEEL PARTS

Observe these precautions when repairing 1,500 MPa steel parts:

- NEVER attempt to straighten damaged 1,500 MPa steel parts because they may crack.
- 1,500 MPa steel parts MUST be replaced at factory seams using squeeze-type resistance spot welding (STRSW).
- MIG brazed joints should be used ONLY in locations not accessible by a spot welder.
- To assure adequate weld tensile strength, always set the spot welder to the specifications provided in the body repair manual.

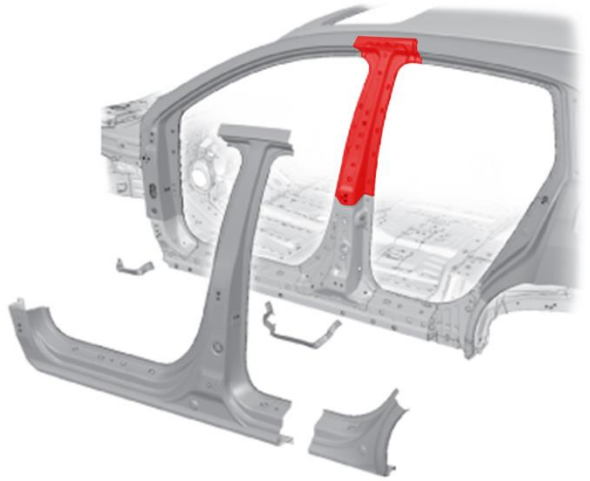

### **Important Information**

Parts made of Ultra High Strength Steel (UHSS/1,500MPa/ USIBOR) must be installed as a complete part. No sectioning allowed. Ultra High Strength Steel requires special welding equipment, procedures, and settings. See the welding section of the appropriate body repair manual. Failure to use the proper equipment or follow the proper procedures can result in an unsafe repair.

- NEVER perform MAG welding on 1,500 MPa steel. The heat generated during welding will significantly reduce the strength and structural integrity of 1,500 MPa steel parts.
- This photo shows tensile strength test results of welded 1,500 MPa steel. The 1,500 MPa steel fractured first, because the welding heat reduced its strength to far below 590 MPa.
- For more information, refer to “Hot Stamp (1,500 MPa) Parts Welding Specifications” in the body repair manual.

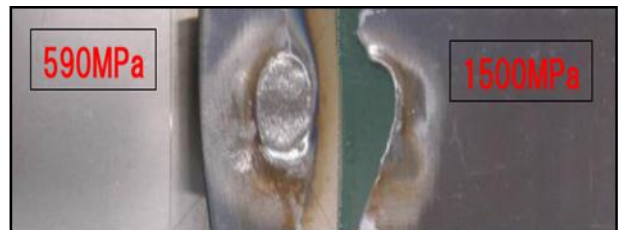

Tensile Test Results of Welded 1,500 MPa Steel

## MIG BRAZING GUIDELINES FOR 1,500 MPa STEEL PARTS

Refer to the body repair manual for complete information:

- MIG brazed joint locations are specified in the body repair manual.
- A single- or double- hole MIG braze may be specified in the body repair manual depending on the tensile strength of the parts being joined.
- The size and number of holes are critical to achieving adequate joint strength.
- A pulsed MIG welder MUST be used. Refer to the equipment manufacturer's instructions for welder voltage and current setup.
- The photos at right show the difference in results between pulsed and non-pulsed MIG brazing.

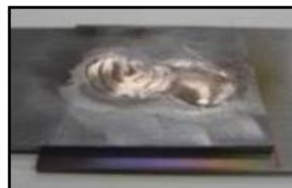

Pulsed MIG (OK)



w/o Pulsed MIG (Bad)

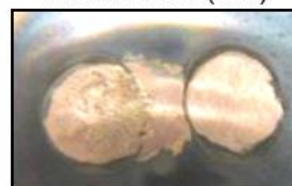



## MAG WELDING SPECIFICATIONS FOR 590-980 MPa HIGH-STRENGTH STEEL PARTS

NOTE: In this publication and the body repair manuals, gas metal arc welding (GMAW) is referred to by its subtypes depending on the welding/brazing requirements:

- **MIG welding/brazing** = Metal inert gas welding or brazing where 100% argon (Ar) shielding gas is used. Argon is inert and does not react with the molten weld pool or brazing operation.
- **MAG welding** = Metal active gas welding where the shielding gas being used contains a mixture of 80% argon (Ar) and 20% carbon dioxide (CO<sub>2</sub>). It is considered active because the CO<sub>2</sub> undergoes a limited reaction with the molten weld pool.

The body repair manual specifies the weld types and locations for each body panel:

- The welding wire used must have a tensile strength equal to, or greater than, the lowest tensile strength of the parts being welded. This conversion chart shows the relationship of steel tensile strength (MPa) to the minimum welding wire tensile strength (ksi).
- Typical ER70S-6 MIG wire has a minimum tensile strength of 70 ksi (483 MPa). It can be used when welding up to 440 MPa steel parts. Refer to the diagrams shown below:

### Important Information

Parts made of High Strength Steel (590-980 MPa) must be installed as a complete part. No sectioning is allowed unless a procedure is provided in the body repair manual. This high-strength steel requires special welding equipment, procedures and settings. See the welding section of the appropriate body repair manual. Failure to use the proper equipment or follow the proper procedures can result in an unsafe repair.

Steel Tensile (MPa)	Wire Tensile (ksi)
590	≥86
780	≥113
980	≥142

(1,000 psi = 1 ksi)

#### MAG Plug Welds

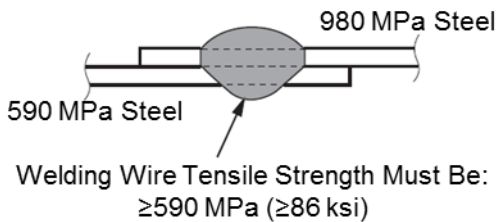

#### MAG Butt Welds

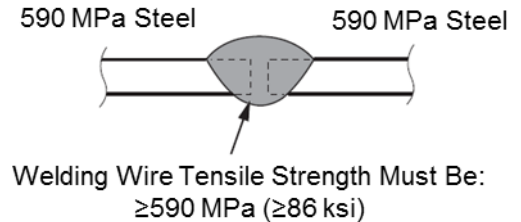

#### MAG PLUG WELDING GUIDELINES

- MAG plug welding may be done when joining body components to 590-980 MPa steel parts.
- Follow the recommendations described in the body repair manual section "MAG welding specifications for high-strength steel parts 590 MPa and higher."

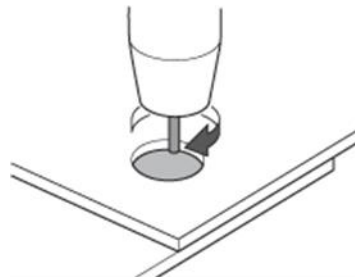

MAG Plug Welding

#### MAG BUTT WELDING GUIDELINES

- MAG butt welding may be done only on steel parts with a tensile strength of 590 MPa and lower.
- Welding speed is critical to achieve the correct weld strength and minimize the heat affected zone (HAZ).
- Follow the recommendations described in the body repair manual section "MAG welding specifications for high-strength steel parts 590 MPa and higher."

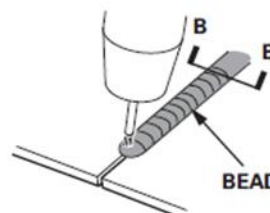

MAG Butt Welding

# Airbag System Components and Repairs

## AIRBAG SYSTEM COMPONENTS

The airbag system in this vehicle includes the following components that may deploy in a collision:

1. Driver and front passenger seat belt tensioners (may deploy independently from any airbags).
2. Driver and front passenger SRS airbags.
3. Side airbags mounted in the outer driver and front passenger seat-backs.
4. Left- and right-side curtain airbags mounted above the side windows under the headliner.

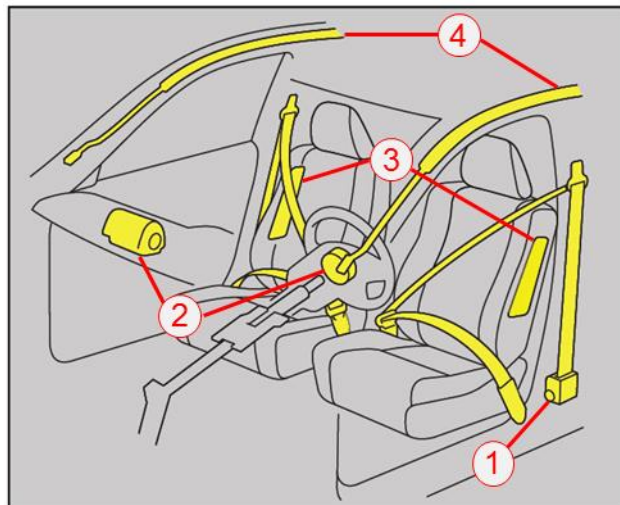

## AIRBAG SYSTEM INDICATORS

There are three indicators used for the airbag system:

### Supplemental Restraint System (SRS) Indicator

When you turn the vehicle to the ON mode, this indicator should come on and then turn off after about 6 seconds.

- If the SRS indicator does not go off, or does not come on at all, there is a problem with the system.
- DTCs must be read and cleared using the HDS (or equivalent) scan tool. Contact a Honda dealer for assistance if necessary.
- If a vehicle is sent to the dealer for airbag system repair or troubleshooting, include a copy of the repair estimate with part numbers and the source for any replaced airbag system parts.



SRS Indicator

### Passenger Airbag OFF Indicator

The indicator comes on to alert you that the passenger's front airbag has been turned off.

- This occurs when the front passenger's weight sensors detect 65 lb. (29 kg) or less, the weight of an infant or small child, on the seat.
- If the indicator comes on with no front passenger and no objects on the seat, or with an adult occupying the seat, something may be interfering with the seat weight sensors, or there may be a problem with the system. Refer to "SRS Symptom Troubleshooting" in the service manual, or contact a Honda dealer for assistance if necessary.



Passenger Airbag OFF Indicator

### Side Airbag OFF Indicator

This indicator comes on when the OPDS sensor detects that the front passenger side airbag needs to be shut off for safety:

- This may occur because the passenger is too small to be sitting in the front seat, is slouching or not sitting upright, or has leaned into the airbag's deployment path.
- This light is not used to indicate problems with the OPDS or airbag system.



Side Airbag OFF Indicator

## AIRBAG SYSTEM ELECTRICAL REPAIRS

Except when doing electrical inspections that require battery power, always turn the vehicle to the OFF (LOCK) mode, disconnect the negative battery cable, then wait at least 3 minutes before starting work.

- For easier identification, electrical connectors that contain only airbag system wiring are yellow in color.
  - Many harnesses that contain primarily airbag wiring are also wrapped in yellow tape.
  - Airbag system wiring that runs in a common harness, such as a floor harness, is generally not marked.
  - NEVER attempt to modify, splice, or repair airbag system wiring.
- If airbag system wiring is damaged, replace the wiring harness(es).

NOTE: Refer to the service manual for complete restraint system operation, diagnostic, and repair information.





# Electrical Repair Information

## TIRE PRESSURE MONITORING SYSTEM (TPMS)

This vehicle is equipped with an initiator-type TPMS.

- The low tire pressure/TPMS indicator comes on if the air pressure is too low in one or more tires. TPMS messages will also appear on the multi-information display in the gauge control module.
- The TPMS indicator will stay on and the system will set DTCs if all four tire pressure sensor IDs are not memorized by the TPMS control unit after you replace a wheel and/or tire pressure sensor.
- Refer to “Memorizing a Tire Pressure Sensor ID” in the service manual for complete information.
- The HDS (or equivalent) scan tool may be required to perform this memorization. Contact an Acura dealer for assistance, if necessary.



Low Tire Pressure/TPMS Indicator

## ELECTRICAL GROUND WIRE PROTECTION

- Painting over electrical ground locations may cause electrical systems, such as Vehicle Stability Assist (VSA), to malfunction and set DTCs that may be difficult to diagnose.
- Protect the ground wire and the ground wire mounting hole threads with a bolt or plug when priming or painting.

