

## Body Repair News

MODEL/YEAR MODÈLE /ANNÉE	DATE OF ISSUE DATE EN VIGUEUR	BULLETIN NUMBER NUMÉRO DU BULLETIN
2016 PILOT	DEC. 10, 2015	J-18-15

### 2016 Pilot: New Model Body Repair Information

**DISCLAIMER:** This publication contains a summary of new body and vehicle technology that may affect collision and other body repairs. Always refer to the appropriate electronic service manual and body repair manual for complete repair information. A subscription may be purchased at: [techinfo.honda.com](http://techinfo.honda.com)

#### TABLE OF CONTENTS

New Model Body Technology	Page 2
Body Repair Information	Page 7
Welding Precautions and Information	Page 8
Airbag System Components and Repairs	Page 10
Electrical Repair Information	Page 12

#### OVERVIEW OF BODY FEATURES

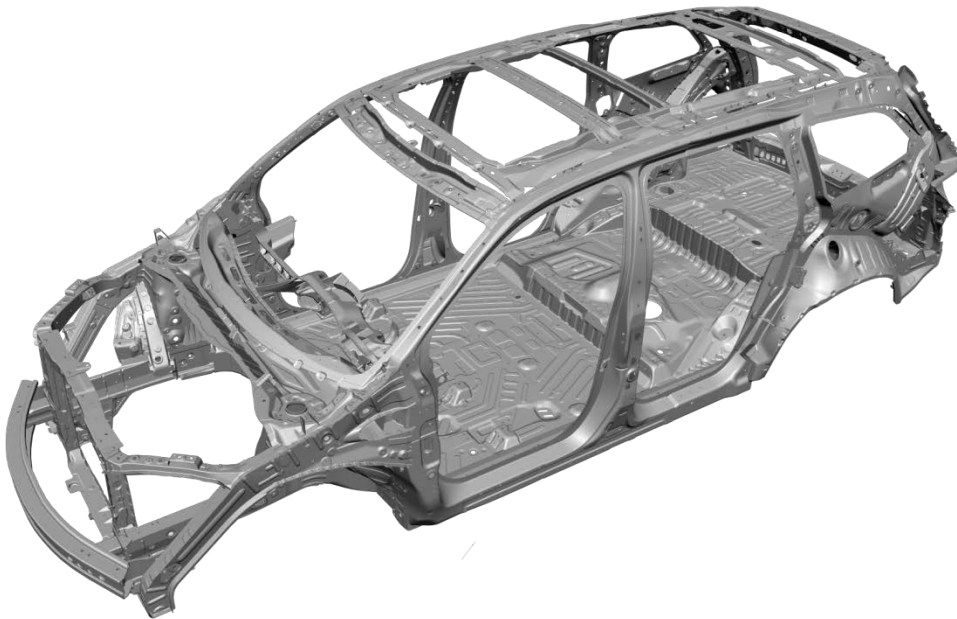

- Next-Generation Advanced Compatibility Engineering™ (ACE™) body structure.
- Body construction using 60% high-tensile-strength steel (HSS), including 21% ultra-high-strength steel (UHSS - 980 MPa and higher).
- Reinforced cabin with 1,500 MPa front door outer stiffener rings and reinforced roof structure.
- “3-bone” platform with additional stiffeners.
- Composite body inner structure (CBIS) applied at multiple locations to increase body rigidity and strength.

# New Model Body Technology

## BODY CONSTRUCTION AND HIGH-STRENGTH STEEL CONTENT

- Steel parts are color coded based on their tensile strength in megapascals (MPa).
- High-strength steel (HSS) is defined as any steel with a tensile strength of 340 MPa or higher.
- Ultra-high-strength steel (UHSS) is defined as any steel with a tensile strength of 980 MPa or higher.
- Steel repair and welding procedures vary depending on the tensile strength of the parts involved.

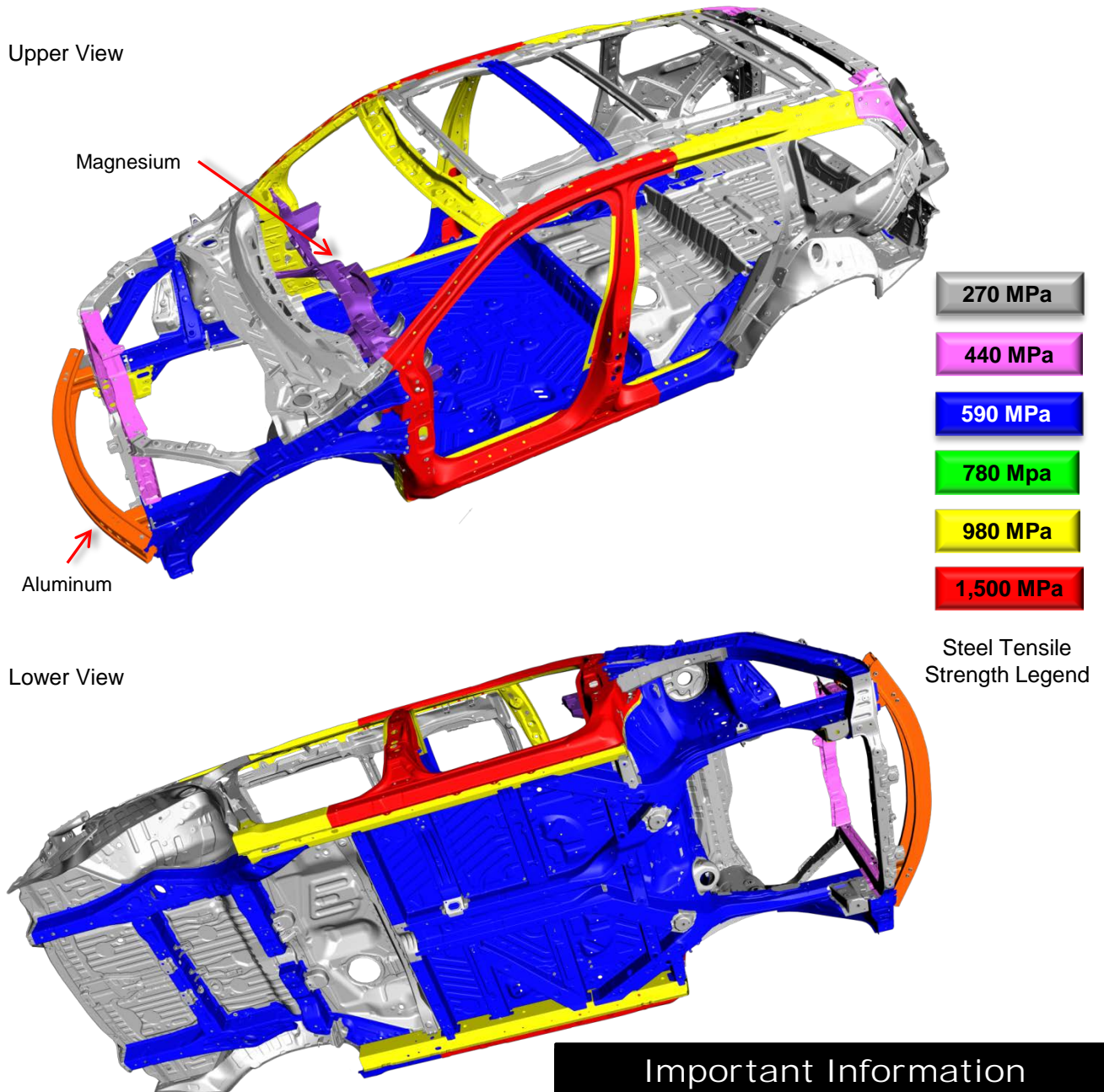

### Important Information

These illustrations are for general reference only. Some body parts are constructed from multiple layers of different tensile strength steels. Always refer to the body repair manual's body construction section for specific steel tensile strength information.

### 1,500 MPa (HOT STAMP) STEEL LOCATIONS

1,500 MPa steel is stronger than ordinary steel, so it can help protect vehicle occupants while reducing overall vehicle weight to improve fuel efficiency.

- The door outer stiffener rings are constructed of 1,500 MPa steel:

NOTE: The door outer stiffener rings **must** be replaced as a single assembly if damaged.

- The stiffener rings are constructed from multiple stampings that are spot welded together at the factory.
- With the door ring assembled and installed, there is no spot welder access to these factory joints, so they **cannot** be repaired.
- The door ring service part is sold as a complete assembly.
- **Do not** substitute MAG welding or MIG brazing for these factory spot welds on the door ring.

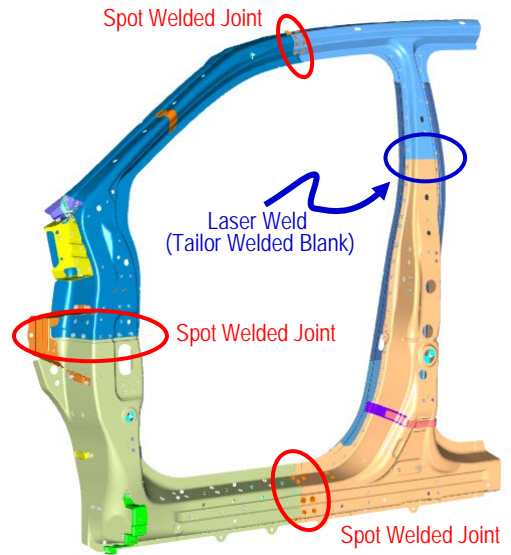

Door Outer Stiffener Ring Construction

### 3-BONE PLATFORM STRUCTURE

A “3-bone” platform structure is used on this vehicle.

- The structure improves impact load management around the cabin while reducing weight.
- Additional floor reinforcements may require replacement or spot weld removal if damaged in a collision.
- Limited sectioning allowed to the front side frame and rear frame B parts. Refer to the body repair manual for complete information.

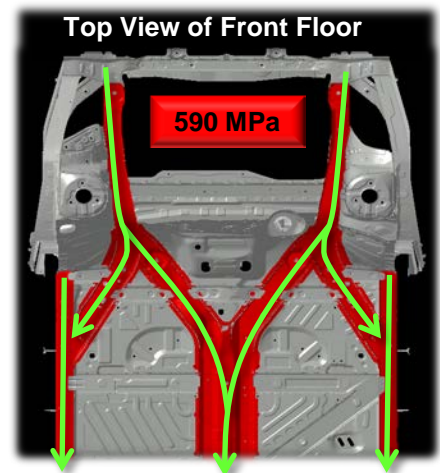

Green Arrows = Impact Load Paths

### ACOUSTIC SIDE DOOR GLASS

Acoustic front side door glass is used for sound isolation on Touring and Elite models.

- The glass has a sound insulation layer of polyvinyl butyral (PVB) sandwiched between two layers of semi-tempered glass.
- Acoustic glass is thinner than conventional glass.
- Its construction is similar to laminated windshield glass, so it doesn't shatter like conventional side window glass.
- Provide the VIN when ordering parts to ensure the correct replacement glass is installed.

Position	LX, EX & EX-L	Touring, Elite
Front Windshield	4.7t laminated	4.5t acoustic laminated
Front Door Glass	5.0t tempered	4.8t acoustic laminated
Rear Door Glass	4.0t tempered	5.0t tempered

t = Glass Thickness In mm



## COMPOSITE BODY INNER STRUCTURE (CBIS)

CBIS is used in strategic body locations to increase global rigidity and local buckling resistance.

- Factory CBIS uses L&L Products L-5520 expanding structural foam (Not commercially available), which expands during the E-coat bake process.
- CBIS is applied at the following locations:
  - Dashboard upper (Loc. A).  
(Elite models with panoramic roof only)
  - Upper center pillar with composite insert (Loc. B).
  - Rear pillar upper (Loc. C).
  - Center frame bracket (Loc. D).

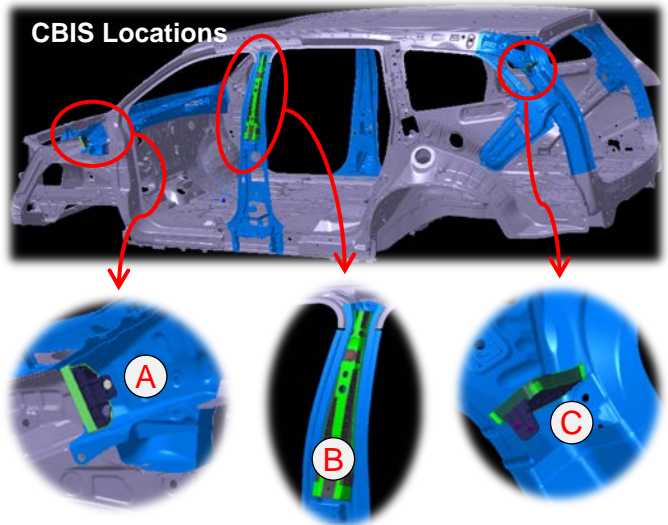

### CBIS Service During Body Repairs

- CBIS locations B & C have the structural foam pre-installed and baked.
- CBIS locations A & D require a special room-temperature cured, 2-part epoxy, expandable structural adhesive (L&L Products L-0504 or equivalent) to replicate these joints.
- Because of limited shelf life, the adhesive must be ordered at the same time as the replacement parts.
- Once the adhesive/foam is applied, the parts can be assembled and welded. The repair adhesive material will cure at room temperature in 24 hours.

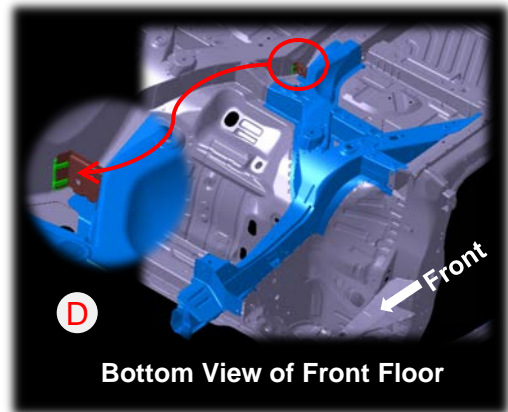

## ACOUSTIC SEPARATOR LOCATIONS

A combination of molded, extruded, and tape acoustic separators are applied in various body locations.

- These are applied within the body pillars.
- They are designed to block the noise paths into the cabin from hollow body cavities.
- Repairs are similar to previous models using commercially available products.

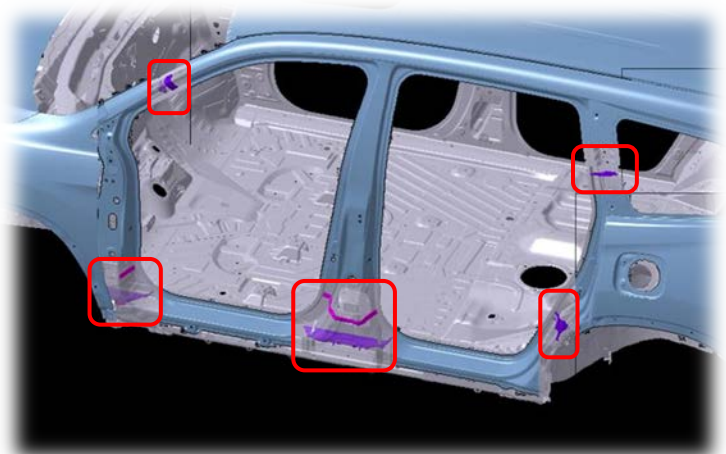

## ALUMINUM PARTS & REPAIRABILITY

All of the parts shown here use aluminum alloy construction.

### Repairability Issues:

- Do not repair bumper beams if damaged.
- Minor damage to the aluminum hood may be repaired by body shops that have dedicated aluminum repair facilities and tools.
- To prevent galvanic corrosion, some fasteners for aluminum parts are considered one-time use and must be replaced if removed.

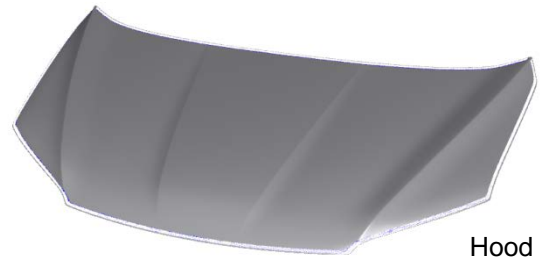

Hood

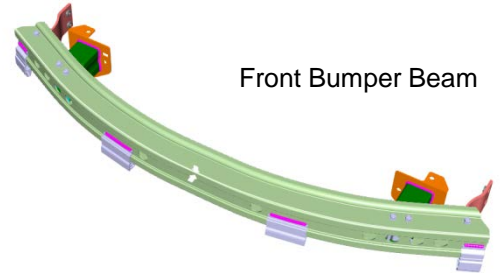

Front Bumper Beam

## MAGNESIUM STEERING HANGER BEAM

The steering hanger beam provides mounting for the steering column and dashboard components.

- The beam is constructed from magnesium alloy for weight savings.
- Do not repair the steering hanger beam if it is damaged.
- Special threaded collar bolts are used in five body mounting locations of the beam to compensate for any variation in body dimensions.
- A specific installation and bolt tightening procedure is required.
- Refer to "Dashboard/Steering Hanger Beam Removal and Installation" in the electronic service manual for complete information.

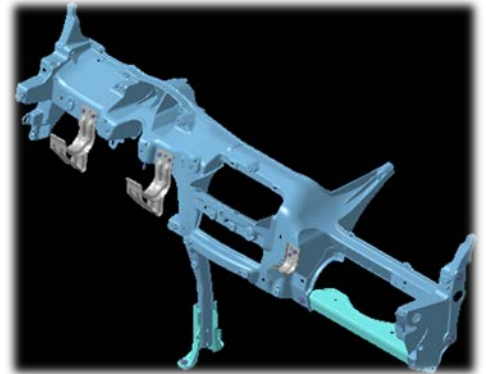

Steering Hanger Beam

## MAG-FORM® BOLTS AND STUDS

- Special MAG-Form bolts and studs are used to fasten dashboard components and electrical grounds to the magnesium steering hanger beam.
- These bolts have a 105° flank angle that self-forms threads into the beam as the bolt is installed.
- If any original hole in the beam is stripped, it can be repaired by ordering a +1 mm oversize service bolt or stud.
- MAG-Form service bolts will form the new repair threads during installation – no drilling or tapping required.
- Always use a torque wrench to tighten MAG-Form bolts or studs to the specifications in the electronic service manual.
- Do not use power tools; the threads formed in the magnesium steering hanger beam are easily stripped.
- If an oversize service bolt or stud has been installed and strips, the steering hanger beam must be replaced.

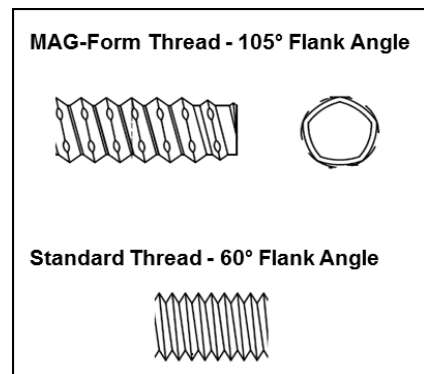

## BLIND SPOT INFORMATION (BSI) SYSTEM

Models equipped with this system can be identified by this BSI Alert indicator, located on both front doors near the outside rearview mirror.

- The system uses two radar units, one mounted on each side of the vehicle under the rear bumper.
- The system may malfunction and set DTCs because of damage, improper repairs, or excessive foreign material on any of the following:
  - Rear bumper
  - Outer side panels
  - Radar unit mounting locations
- Several checks and inspections must be done during repairs to the radar unit mounting area.
- If the mounting area check is not done, a Honda dealer may not be able to properly aim the radar units.
- For more information, refer to “BSI Radar Unit Mounting Area Check” in the electronic service manual.



BSI Alert Indicator

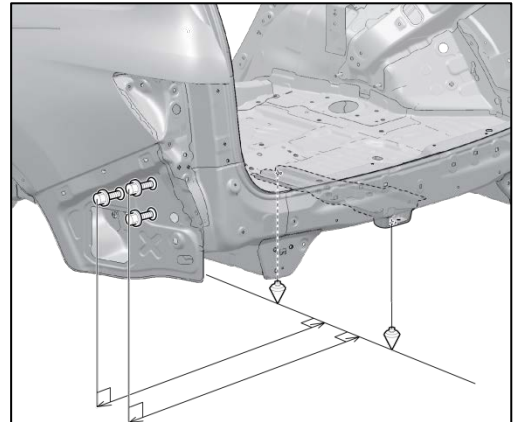

LH BSI Unit Mounting Area Check  
(RH Side is symmetrical)

## CAPLESS FUEL FILLER

This vehicle uses a capless fuel filler design. It does not have a conventional gas cap.

- If you need to refuel the vehicle from a portable fuel container, a funnel is located behind a removable panel on the left side of the cargo area interior trim.
- The fuel system can be damaged by inserting the nozzle of a portable fuel container directly or by using any funnel other than the one provided with the vehicle.
- For more information, refer to “Refueling From a Portable Fuel Container” in the owner’s manual.



Capless Fuel Filler

## TOWING AND LIFTING PRECAUTIONS

- AWD models must be towed using flat bed towing equipment to prevent AWD system damage.
- 2WD models may be towed using front wheel lift or flat bed towing equipment.

For more information, refer to “Emergency Towing” in the owner’s manual or electronic service manual.

- Lift or jack only at the specified points to avoid damaging the vehicle.
- **Do not** lift or tow this vehicle by its bumpers or serious damage will result.

For more information, refer to “Lift and Support Points” in the electronic service manual.



# Body Repair Information

NOTE: The following content is intended only to highlight new/special concerns. No body repairs should be attempted without first referencing the appropriate body repair manual for complete information.

## USE OF HEAT DURING BODY STRAIGHTENING AND REPAIR

When you are doing body straightening and repair procedures, follow these guidelines:

- **Do not** apply heat to any body part during straightening. This may compromise the internal structure and strength of high-strength steel parts.
- Any part that has heat applied to it during straightening **must** be replaced with new parts.
- Ignoring these instructions may significantly reduce occupant protection in any subsequent collision.

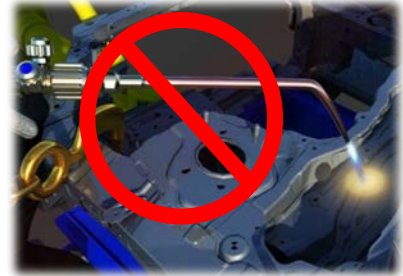

**Do not heat during straightening**

## SECTIONING (CUT AND JOINT) GUIDELINES

Various high-strength steel materials with different sheet thicknesses and strengths are applied in many places that vary by body design in order to increase collision safety performance, body stiffness, and weight reduction. Stiffening members inside each part (patch, stiffener, etc.) are also specified in detail.

Follow these guidelines to avoid an unsafe repair:

- Sectioning (cut and joint) should usually be avoided except for mild steel outer panels and floor panels unless a specific procedure is provided in the body repair manual.
- However, depending on the type of vehicle damage, steel parts with a tensile strength  $\leq 780$  MPa may be sectioned provided **all** of the following conditions are met:
  - Sectioning must be done in a single-layer area of the part.
  - Multi-layer internal steel reinforcements and stiffeners must not be cut.
  - The repair is not in a load-bearing area such as engine, transmission, or suspension mounting points.
- Replace body structural components such as stiffeners, reinforcements, and other multi-layered steel parts as assemblies that match the replacement parts configuration.
- Approved welding methods are listed in the table on the right.
- Refer to the body repair manual section “Parts Sectioning (Cut and Joint) Guidelines” for complete information.

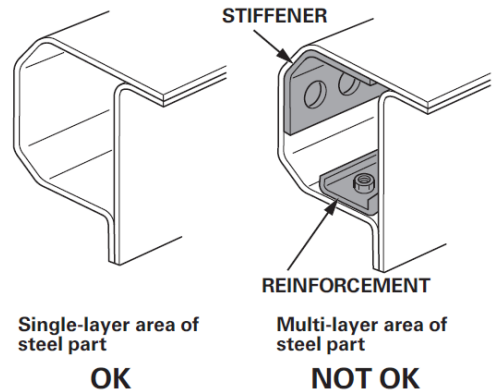

**Sectioning Area Examples**

Steel Part Tensile Strength (MPa)	Welding Method		
	Spot Weld	MAG Welding	
		Plug	Butt
<590	○	○	○
590	○	○	○
780	○	○	○
980	○	○	X
1500	○	X	X

**Welding Methods for Steel Parts**  
(○ = Approved X = Not Approved)



# Welding Precautions and Information

## REPAIRING 1,500 MPa STEEL PARTS

Observe these precautions when repairing 1,500 MPa steel parts:

- **Never** attempt to straighten damaged 1,500 MPa steel parts; they may crack.
- 1,500 MPa steel parts **must** be replaced at factory seams using squeeze-type resistance spot welding (STRSW). **Do not section these parts!**
- MIG brazed joints should be used **only** in locations not accessible by a spot welder.
- To assure adequate weld tensile strength, always manually set the spot welder to the specifications provided in the body repair manual.

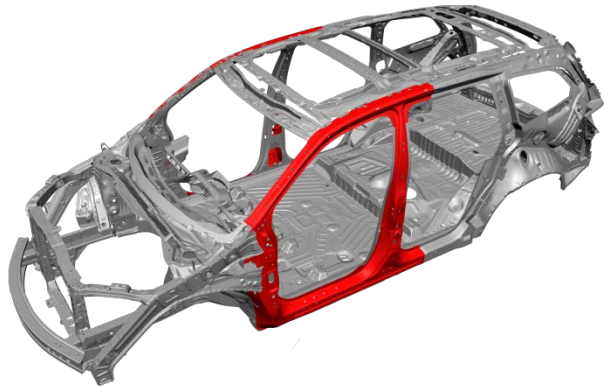

## Important Information

Parts made of Ultra-High-Strength Steel (UHSS/1,500MPa/USIBOR) must be installed as a complete part. No sectioning allowed. Ultra High-Strength Steel requires special welding equipment, procedures, and settings. See the welding section of the appropriate body repair manual. Failure to use the proper equipment or follow the proper procedures can result in an unsafe repair.

- **Never** do MAG welding on 1,500 MPa steel. The heat generated during MAG welding will significantly reduce the strength and structural integrity of 1,500 MPa steel parts.
- The photo on the right shows tensile strength test results of MAG welded 1,500 MPa steel. The 1,500 MPa steel fractured first because the welding heat reduced its strength to far below 590 MPa.
- For more information, refer to “Repair Guidelines for High-Strength Steel Parts” in the body repair manual.

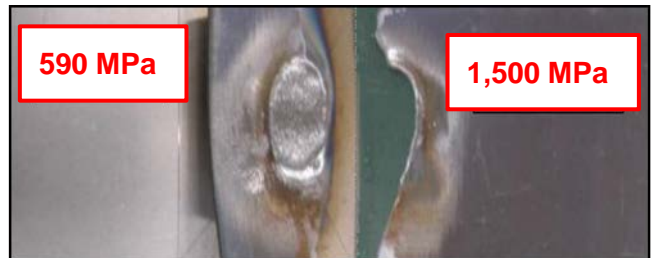

Tensile Test Results of MAG-Welded 1,500 MPa Steel

## MIG BRAZING GUIDELINES FOR 1,500 MPa STEEL PARTS

Refer to the body repair manual for complete information:

- MIG-brazed joint locations are specified in the body repair manual.
- A single- or double-hole MIG braze may be specified in the body repair manual depending on the tensile strength of the parts being joined.
- The size and number of holes are critical to achieving adequate joint strength.
- A MIG welder with pulse control **must** be used. Refer to the equipment manufacturer's instructions for welder voltage and current setup.
- The photos on the right show the difference in results between pulsed and non-pulsed MIG brazing.

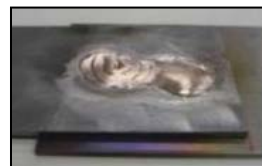

Pulsed MIG (OK)



w/o Pulsed MIG (NG)





## MAG WELDING SPECIFICATIONS FOR 590–980 MPa HIGH-STRENGTH STEEL PARTS

NOTE: In this publication and the body repair manuals, gas metal arc welding (GMAW) is referred to by its subtypes depending on requirements as follows:

- **MIG welding/brazing** = Metal inert gas welding or brazing where 100% argon (Ar) shielding gas is used. Argon is inert and does not react with the molten weld pool or brazing operation.
- **MAG welding** = Metal active gas welding where the shielding gas being used contains a mixture of 80% argon (Ar) and 20% carbon dioxide (CO<sub>2</sub>). It is considered active because the CO<sub>2</sub> undergoes a limited reaction with the molten weld pool.
- For MAG welding, 80/20 shielding gas (C20) is preferred. However, 75/25 (C25) is acceptable

The body repair manual specifies the weld types and locations for each body pane as follows:

- The welding wire used must have a tensile strength equal to or greater than the lowest tensile strength of the parts being welded. The conversion chart on the right shows the relationship of steel tensile strength (MPa) to the minimum welding wire tensile strength (ksi).
- Typical ER70S-6 MIG wire has a minimum tensile strength of 70 ksi (483 MPa). It can be used when welding up to 440 MPa steel parts. Refer to the diagrams shown below:

### Important Information

Parts made of High-Strength Steel (590-980 MPa) must often be installed as a complete part. Section only according to published repair information and guidelines. This high-strength steel requires special welding equipment, procedures, and settings. See the welding section of the appropriate body repair manual. Failure to use the proper equipment or follow the proper procedures can result in an unsafe repair.

Steel Tensile (MPa)	Wire Tensile (ksi)
590	≥86
780	≥113
980	≥142

(1,000 psi = 1 ksi)

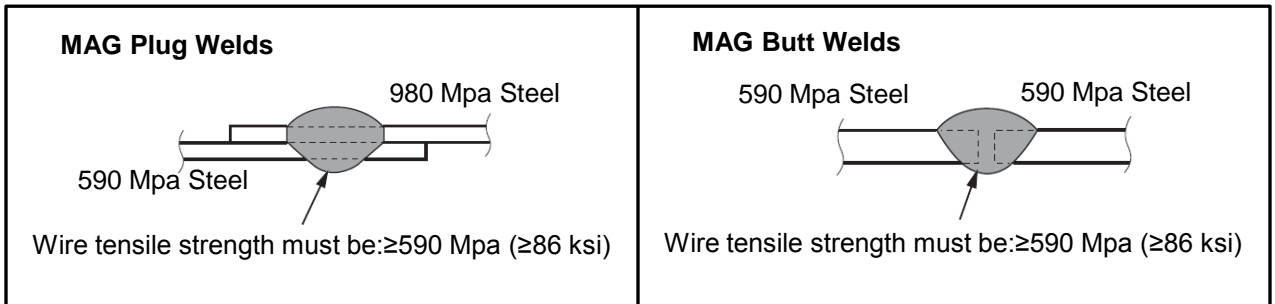

### MAG PLUG WELDING GUIDELINES

- MAG plug welding may be done when joining body components to 590–980 MPa steel parts.
- Follow the recommendations described in the basic body repair manual “Repair Guidelines for High-Strength Steel Parts” and “MAG Welding Conditions for High-Strength Steel (Except 1,500 MPa) Parts.”

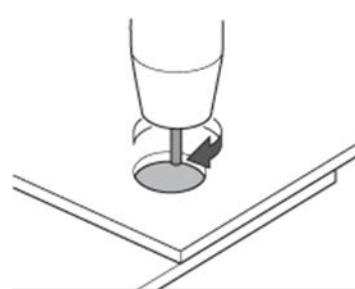

MAG Plug Welding

### MAG BUTT WELDING GUIDELINES

- MAG butt welding may be done **only** on steel parts with a tensile strength of 780 MPa and lower.
- Welding speed is critical to achieve the correct weld strength and minimize the heat affected zone (HAZ).
- Follow the recommendations described in the basic body repair manual “Repair Guidelines for High-Strength Steel Parts” and “MAG Welding Conditions for High-Strength Steel (Except 1,500 MPa) Parts.”

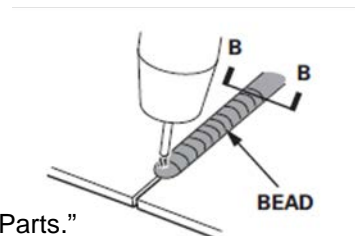

MAG Butt Welding

# Airbag System Components and Repairs

## AIRBAG SYSTEM COMPONENTS

The airbag system in this vehicle includes the following components that may deploy in a collision:

1. Driver's and front passenger's seat belt tensioners (may deploy independently from any airbags).
2. Driver's and front passenger's SRS airbags.
3. Side airbags mounted in the driver's and front passenger's outer seat-backs.
4. Side curtain airbags mounted above the left and right side windows under the headliner.

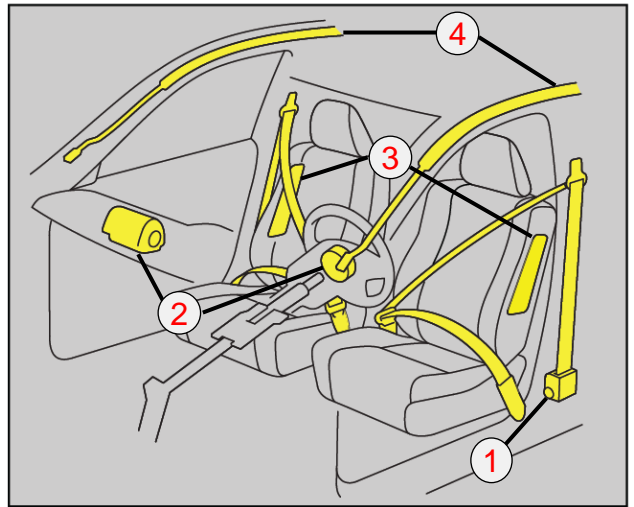

## SMARTVENT™ SIDE AIRBAGS

This vehicle is equipped with SmartVent side airbags:

- This airbag design helps mitigate the risk of excessive airbag deployment force and risk of injury to smaller seat occupants.
- It eliminates the need for the occupant position detection system (OPDS) sensor located in the front passenger's seat-back.

As with all side airbags, the following service precautions apply:

- Special seat covers and/or breakaway thread are used to ensure the proper deployment path.
- Damaged front seat covers should be replaced, not repaired.
- Do not install non-factory seat covers; they may alter the airbag's intended deployment path.

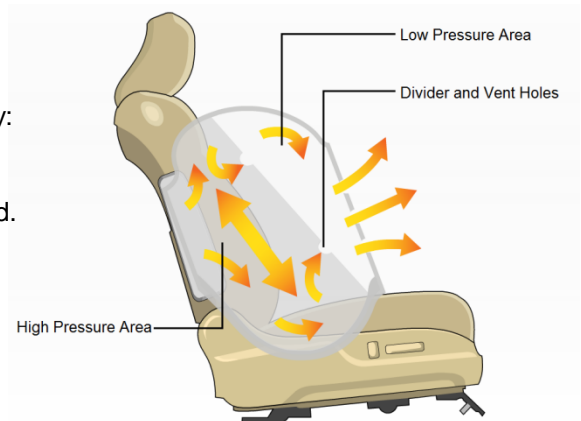

SmartVent Side Airbag

## AIRBAG SYSTEM INDICATORS

There are two indicators used for the airbag system.

### Supplemental Restraint System (SRS) Indicator

When you turn the ignition to ON, this indicator should come on and then turn off after about 6 seconds.

- If the SRS indicator does not go off or does not come on at all, there is a problem with the system.
- DTCs must be read and cleared using the HDS (or equivalent) scan tool. Contact a Honda dealer for assistance if necessary.
- If a vehicle is sent to the dealer for airbag system repair or troubleshooting, include a copy of the repair estimate with part numbers and the source for any replaced airbag system parts.



SRS Indicator

### PASSENGER AIRBAG OFF Indicator

The indicator comes on to alert you that the passenger's front airbag has been turned off.

- This occurs when the front passenger's weight sensors detect about 65 lb. (29 kg) or less, the weight of an infant or small child on the seat.
- If the indicator comes on with no front passenger and no objects on the seat or with an adult occupying the seat, something may be interfering with the seat weight sensors or there may be a problem with the system. Contact a Honda dealer for assistance if necessary.



PASSENGER AIRBAG OFF Indicator

## AIRBAG SYSTEM REPAIRS REQUIRED AFTER DEPLOYMENT

To restore proper function and allow DTCs to be cleared, the airbag system **must** be repaired as specified in the electronic service manual. Refer to "Component Replacement/Inspection After Deployment" for complete information.

- **Do not** install used, refurbished, or modified airbag system parts!
- When making airbag system repairs, only use new genuine replacement parts, which are manufactured to the same standards and quality as the original parts.
- To ensure the correct replacement airbag system parts are installed, provide the VIN when ordering parts. Compare the part numbers on the new and removed parts to make sure they match.

## AIRBAG SYSTEM ELECTRICAL REPAIRS

Except when doing electrical inspections that require battery power, always turn the ignition to OFF, disconnect the negative battery cable, then wait at least 3 minutes before starting work.

- For easier identification, electrical connectors that contain only airbag system wiring are yellow in color.
- Many harnesses that contain primarily airbag wiring are also wrapped in yellow tape.
- Airbag system wiring that runs in a common harness, such as a floor harness, is generally not marked.
- **Never** attempt to modify, splice, or repair airbag system wiring. If any part of the airbag system wiring is damaged, replace the affected wiring harness(es).

NOTE: Refer to the electronic service manual for complete restraint systems operation, diagnostic, and repair information.



Airbag System Connectors & Harness (Yellow)

# Electrical Repair Information

## TIRE PRESSURE MONITORING SYSTEM (TPMS) WITH FILL ASSIST

This vehicle is equipped with an initiator-type TPMS.

- The Low Tire Pressure/TPMS indicator comes on if the air pressure is too low in one or more tires. TPMS messages will also appear on the multi-information display in the gauge control module.
- TPMS fill assist provides audible and visual guidance during tire pressure adjustment. Refer to the owner's manual for details.
- The TPMS indicator will stay on and the system will set DTCs if all four tire pressure sensor IDs are not memorized by the TPMS control unit after you replace a wheel and/or tire pressure sensor.
- Refer to "Memorizing a Tire Pressure Sensor ID" in the service manual for complete information.
- The HDS (or equivalent) scan tool may be required to do this memorization. Contact a Honda dealer for assistance, if necessary.



Low Tire Pressure/TPMS Indicator

## AUTO IDLE STOP SYSTEM & AGM BATTERY

Touring and Elite models are equipped with an auto idle stop system that improves fuel efficiency by stopping the engine when the vehicle comes to a stop if certain conditions are met. The 12-volt starter and battery are used to restart the engine.

- Auto idle stop increases the 12 volt battery's charge and discharge events.
- A long-life Type L3 absorbed glass mat (AGM) battery is used for its deep-cycle service capabilities.
- To reduce battery temperature, the battery includes an enclosed case with a fan and cooling duct.
- AGM batteries require special charging and test procedures.
- Always replace an AGM battery with the same type or significantly reduced battery life will occur.
- The battery cooling fan does not set any DTCs in the event of a malfunction.

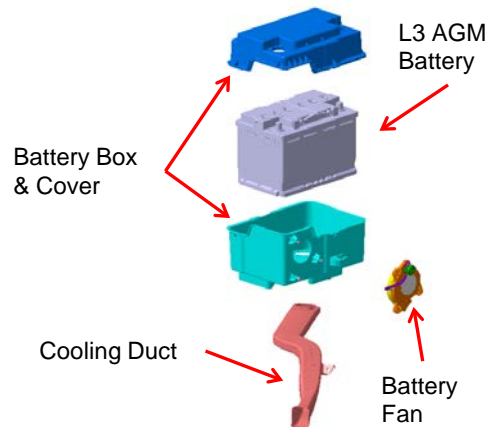

### Auto Idle Stop Indicator Operation:

- The Auto Idle Stop indicator will light up green when auto idle stop is active.
- This indicator will light up amber if the system is switched off. It will also blink amber if there is a system malfunction.
- A warning message may also appear.



Auto Idle Stop Active  
(Engine Off)



Auto Idle Stop Off or Malfunction

- System Off = Solid Indicator
- Malfunction = Blinking Indicator



## AUTO HIGH BEAM SYSTEM

Elite models are equipped with this system. It uses a dedicated camera, mounted under a cover in front of the rearview mirror, to monitor the area ahead of the vehicle and automatically changes the low beam headlights to high beams when necessary.

- The camera is separate from the multipurpose camera used for Honda Sensing™ (FCW/LDW/LKAS) functions.
- A green Auto High Beam indicator lights up in the gauge control module when the system is operational
- If the windshield area around the camera is dirty, the auto high beam system may not operate.
- Do not attach objects, decals, or tint film in the area around the camera.
- Warning messages will appear for system problems.

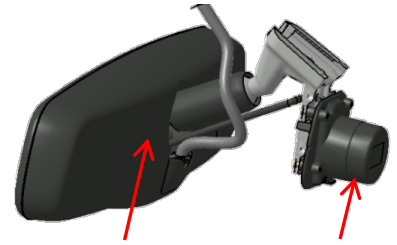

Rearview Mirror

Auto High Beam Camera



Auto High Beam Indicator

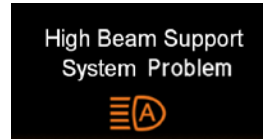

Auto High Beam Warning Messages

## ELECTRONIC GEAR SELECTOR SYSTEM

Touring and Elite models are equipped with an electronic gear selector that uses shift selector buttons to replace the traditional transmission shifter and cable.

- The electronic gear selector control unit has a programmed Park logic when the vehicle is stopped but not in Park. If the driver's seat belt is unbuckled and the driver's door is opened, the vehicle will shift into Park automatically to help prevent a roll-away condition.
- If the vehicle needs to be placed into Neutral with the engine off, such as when pushing to move it, there is a "car wash mode". To enter car wash mode, follow the instructions found under "Shifting" in the owner's manual.
  - The vehicle will remain in Neutral with the ignition in ACCESSORY for 15 minutes.
  - After 15 minutes has elapsed, the selector automatically changes to Park and the ignition turns to OFF.



Electronic Gear Selector

## POWER TAILGATE INFORMATION

Some models include a spindle-type power tailgate:

- The motor and actuator are integrated into the driver's side tailgate support strut.
- Under these conditions, the power tailgate will not open or close automatically until it is reset:
  - The battery is disconnected, or the No. A26 (10 A) fuse in the under-hood fuse/relay box is removed while the power tailgate is operating.
  - Certain power tailgate components have been replaced.
- Refer to "Resetting the Power Tailgate Control Unit" in the electronic service manual for complete information.

Power Tailgate Actuator



## SYSTEMS THAT MAY REQUIRE DEALER ASSISTANCE WITH AIMING

Some models may be equipped with one or more of the following systems that require aiming after collision repairs. Special tools are required to complete the aiming procedures. Contact a Honda dealer for assistance.

### Blind Spot Information (BSI) System with Cross-Traffic Alert:

The BSI radar units must be re-aimed in these instances:

- After replacing or removing and installing one or both BSI radar units.
- After replacing/repairing the body rear outer side panel(s).
- Stored DTCs B18B8 or B1E68 - left or right side BSI radar unit azimuth off alignment.

If a problem occurs in the BSI system, the amber BSI indicator will light up. A warning message may also appear.



BSI Indicator

Blind Spot Info System Problem



### Forward Collision Warning and Lane Departure Warning (FCW/LDW):

The multipurpose camera unit must be re-aimed in these instances:

- The camera unit is removed or replaced.
- The windshield is removed or replaced.

If the aiming is incomplete, the FCW and LDW indicators come on and blink. The FCW and LDW warning messages may also appear.



LDW Indicator



FCW/CMBS Indicator

Forward Collision Warning Problem



Lane Departure Warning Problem



### Adaptive Cruise Control (ACC) and Collision Mitigating Braking System (CMBS):

The millimeter wave radar for the ACC/CMBS must be re-aimed if:

- The radar unit is removed or replaced.
- The radar unit's mounting area was damaged.
- If the aiming process is not completed, or the electronic service manual procedure is not followed, the ACC indicator changes to amber and a warning message may also appear.

Adaptive Cruise Control Problem

ACC

Collision Mitigation System Problem



### Lane Keeping Assist System (LKAS) System:

The multipurpose camera unit must be re-aimed in these instances:

- The camera/control unit is removed or replaced.
- The windshield is removed or replaced.
- If the aiming is not done or is not completed, the LKAS indicator changes to amber and blinks. A warning message may also appear.

Lane Keeping Assist Problem

LKAS

### Windshield Replacement On FCW/LDW/LKAS-Equipped Vehicles:

- Windshield damage within the multipurpose camera unit's field of vision can cause any these systems to operate abnormally.
- Only a genuine Honda replacement windshield should be installed. Installing an aftermarket replacement windshield may also cause abnormal operation.

### LaneWatch™:

LaneWatch uses a camera in the passenger's side door mirror and the center display to help drivers improve the visibility of the passenger side roadway.

The LaneWatch camera must be aimed after one or more of the following procedures are done:

- LaneWatch camera removal or replacement
- Door mirror removal or replacement
- Door panel removal or replacement
- Door panel body repair

LaneWatch does not set DTCs. Troubleshooting and camera aiming are done using the navigation system or center display self-diagnostics.

LaneWatch does not use an indicator to inform the driver of a malfunction.



LaneWatch Camera Location

### **ACC/CMBS GRILLE DIFFERENCES**

Some models are equipped with Adaptive Cruise Control and a Collision Mitigating Braking System™ (CMBS™) that uses a millimeter wave radar unit mounted behind the front grille.

- This unit senses through the front grille emblem base.
- This part, and its Honda emblem, are specially designed to prevent radar interference. This design change also significantly increases the part's cost.
- Installing the wrong front grille emblem base will cause the CMBS indicator to come on and DTC P2583-97 (dust or dirt on the millimeter wave radar) to set.
- The Honda emblem is a flat lens integrated into the base on the correct radar-compatible part.
- The wrong parts were installed on a model equipped with ACC/CMBS if the Honda emblem has a raised texture and is a separate part from the base.

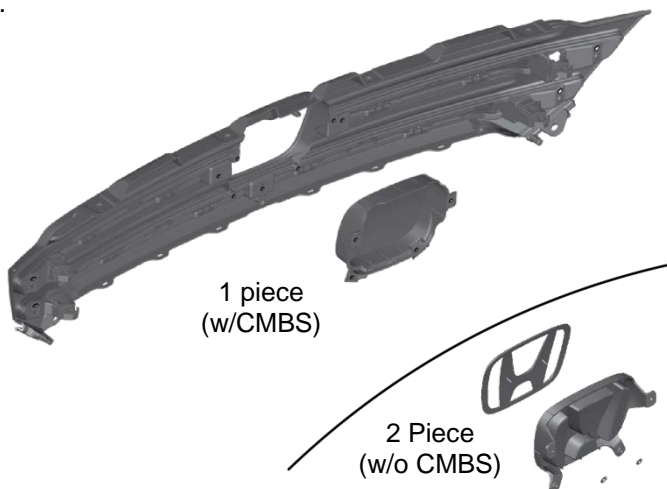

Front Grille Emblem & Bases

### **R-1234yf A/C REFRIGERANT**

This vehicle's A/C system uses the more environmentally-friendly R-1234yf refrigerant.

- R-1234yf refrigerant is considered "mildly flammable". Be sure to observe all basic safety precautions for working around flammable gases. Refer to "A/C Service Tips and Precautions" in the electronic service manual.
- The system should only be serviced by qualified A/C technicians trained to handle R-1234yf refrigerant.
- Refrigerant recovery, charging, and leak detection all require dedicated tools and equipment designed and SAE approved for use with R-1234yf.
- Honda dealers have this equipment. Please contact your local dealer if you need assistance.



## ELECTRICAL GROUND WIRE PROTECTION

- Painting over electrical ground locations may cause electrical systems, such as vehicle stability assist (VSA), to malfunction and set DTCs that may be difficult to diagnose.
- Protect the ground wire and the ground wire mounting hole threads with a bolt or silicone plug when priming or painting.

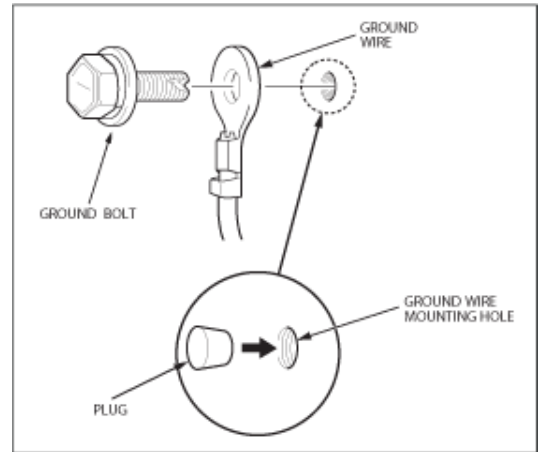

## BATTERY JUMP STARTING/CHARGING/TESTING LOCATIONS

This vehicle uses a 12-volt battery sensor on the negative battery cable at the battery terminal.

- This sensor is fragile and can be damaged during jump starting or battery charging/testing procedures.
- To avoid damage to the battery sensor and the chance of electrical sparks, do not use the negative battery post for these procedures. Instead, connect the negative jumper cable or the testing/charging equipment's negative cable to the engine hanger bracket located on the passenger's side of the engine under the plastic engine cover.



12-Volt Battery Under Hood Jump Starting/Charging/Testing Locations