

MODEL/YEAR MODÈLE /ANNÉE	DATE OF ISSUE DATE EN VIGUEUR	BULLETIN NUMBER NUMÉRO DU BULLETIN
2015-18 Fit	Dec. 11, 2017	J-4-17

## 2015-18 Fit: New Model Body Repair Information

**DISCLAIMER:** This publication contains a summary of new body and vehicle technology that may affect collision and other body repairs. Always refer to the service information manual and Body Repair Manual for complete repair information. A subscription may be purchased at: [techinfo.honda.com](http://techinfo.honda.com)

### TABLE OF CONTENTS

New Model Body Technology	Page 2
Body Repair Information	Page 5
Welding Precautions and Information	Page 6
Airbag System Components and Repairs	Page 8
Electrical Repair Information	Page 10

### OVERVIEW OF BODY FEATURES

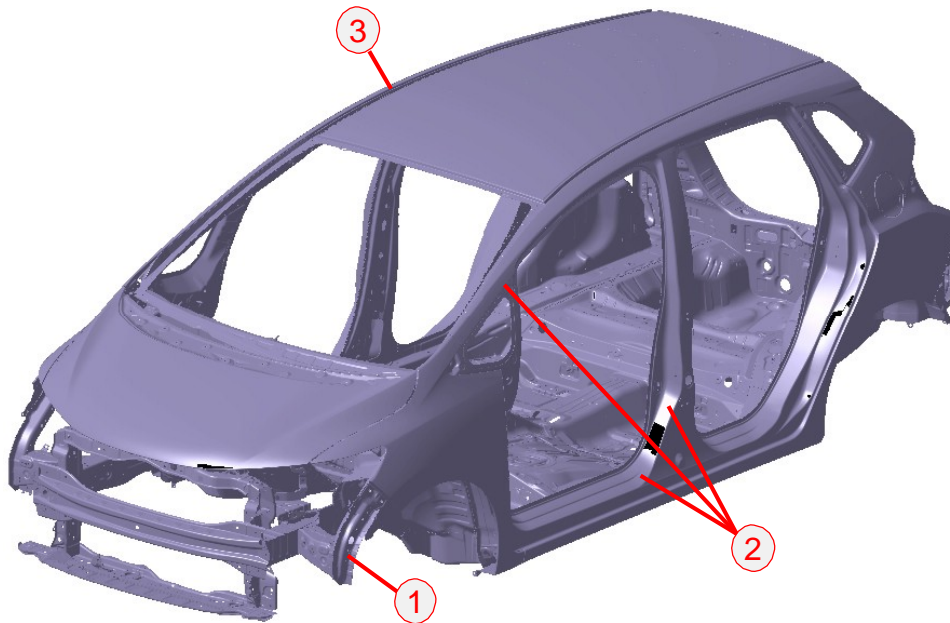

1. Next-Generation Advanced Compatibility Engineering™ (ACE™) body structure.
2. Platform (underbody and chassis) weight reduced by 57 pounds due to the extensive use of high and ultra-high strength steel, including 27% in grades 780, 980, and 1,500 MPa.
3. 4-plate spot welding in roof panel attachment area.

# NEW MODEL BODY TECHNOLOGY

## BODY CONSTRUCTION AND HIGH STRENGTH STEEL CONTENT - 2012-14 MODELS

- Steel parts are color-coded based on their tensile strength in Mega Pascal (MPa).
- High strength steel is defined as any steel with a tensile strength of 340 MPa or higher.
- Steel repair and welding procedures vary depending on the tensile strength of the parts involved.

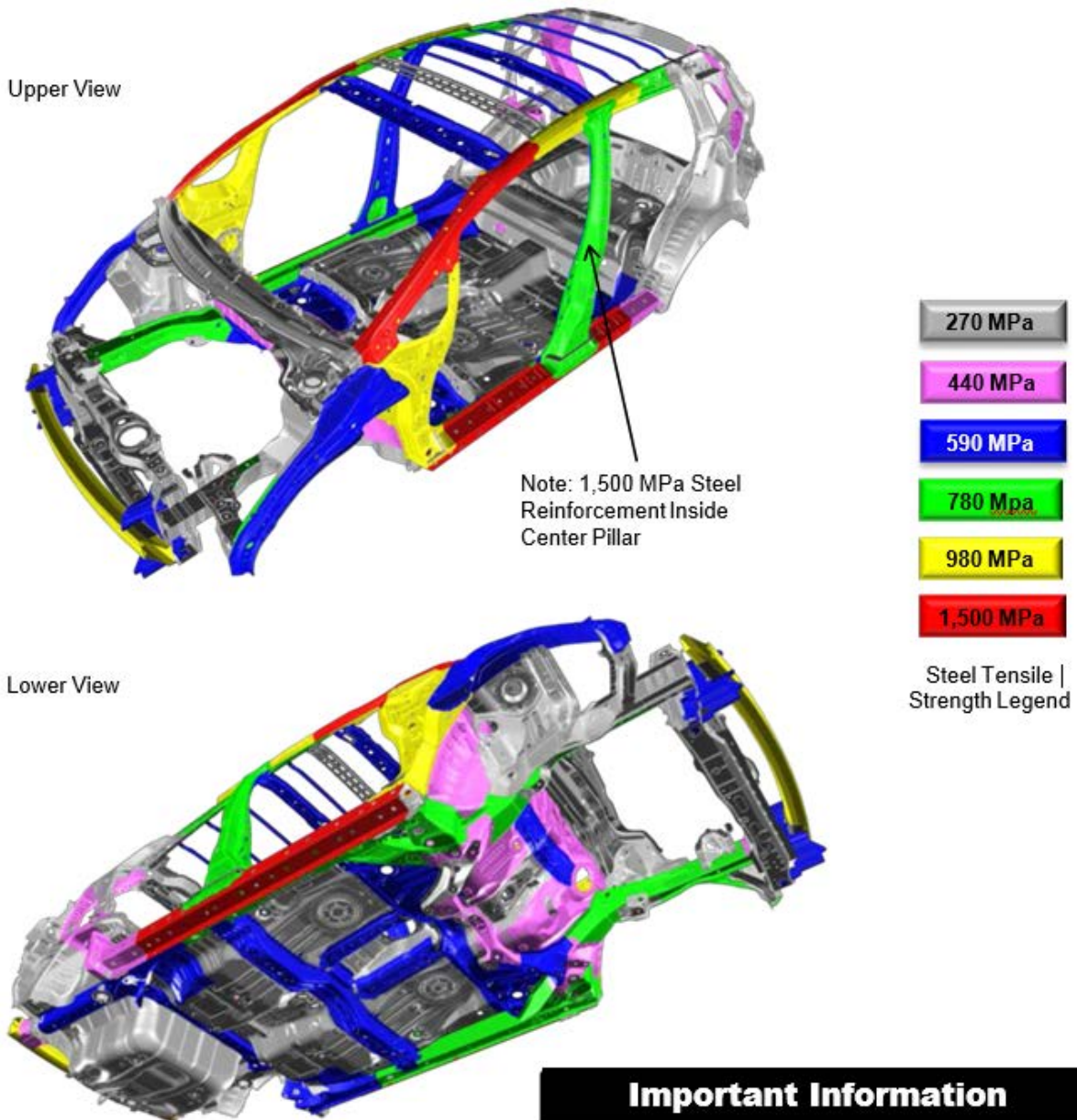

### Important Information

These illustrations are for general reference only. Some body parts are constructed from multiple layers of different tensile strength steels. Always refer to the body repair manual body construction section for specific steel tensile strength information.

## 1,500 MPa (HOT STAMP) STEEL LOCATIONS

1,500 MPa steel is stronger than ordinary steel, so it can help protect vehicle occupants while reducing overall vehicle weight to improve fuel efficiency.

The numbered parts in the diagram below are constructed of 1,500 MPa steel:

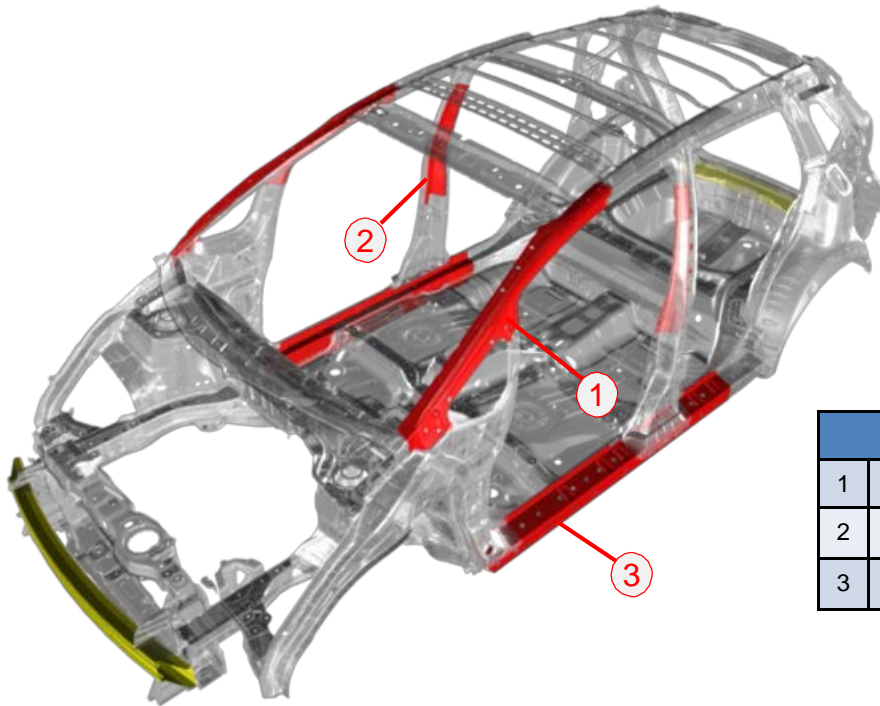

All Fit Models	
1	Front Pillar Upper Stiffener
2	Center Pillar Reinforcement
3	Side Sill Stiffener

## LIFTING AND TOWING PRECAUTIONS

- Flatbed towing equipment is the preferred method to transport this vehicle.
- Front wheel lift towing equipment may also be used to tow this vehicle.
- For more information, refer to “Emergency Towing” in the owner’s manual.
- Lift or jack only at the specified points to avoid damaging the vehicle.
- Do not lift or tow this vehicle by its bumpers, or serious damage will result.
- For more information, refer to “Lift and Support Points” in the service or body repair manual.



#### 4-PLATE SPOT WELDED ROOF PANEL ATTACHMENT

The body of this vehicle is assembled using new technology that welds the entire inner framework before the pre-welded outer body panels are attached. This creates a unique 4-plate spot weld at the roof panel side flanges.

- Squeeze-type resistance spot welding (STRSW) is the required repair method because one of the 4 plates is constructed of 980 and 1,500 MPa steel (depending on location).
- Any squeeze-type resistance spot welder meeting the specifications published in the body repair manual can make this 4-plate spot weld.
- Refer to body repair manual section “Roof Panel Removal and Installation” for complete information.

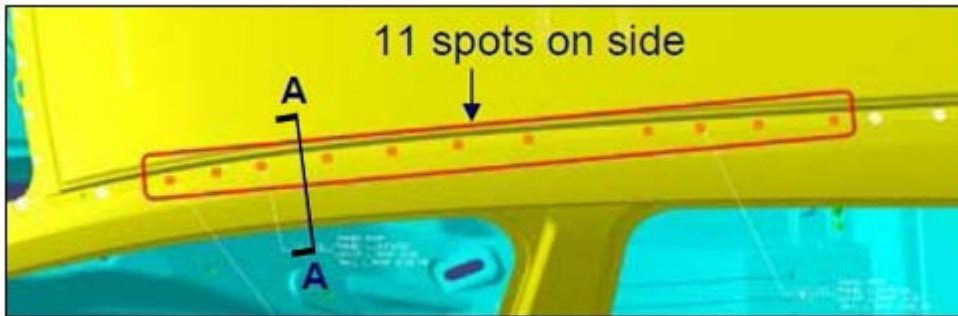

Roof Panel 4-Plate Spot Weld Area

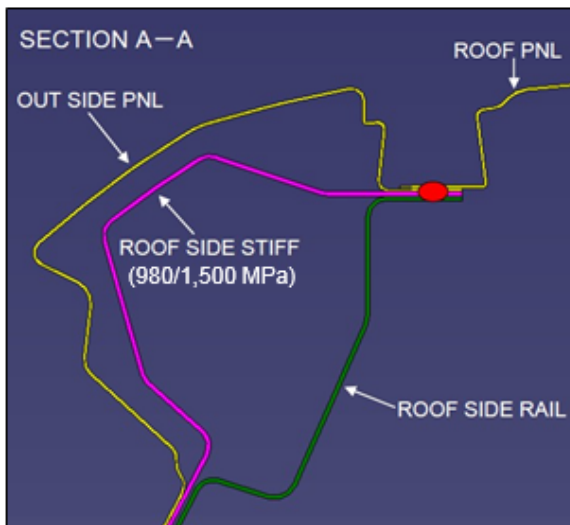

Roof Panel Section A - A

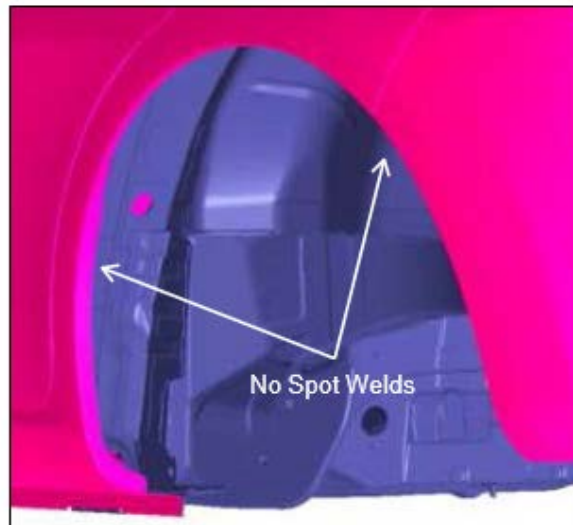

Rear Wheel Arch Area

#### REAR WHEEL ARCH FLANGE – NO SPOT WELDS

The rear wheel arch flange uses a new narrower design that eliminates spot welds to improve appearance.

- The flange is attached and sealed using adhesive (3M AUTO MIX Panel Bonding 8115, or equivalent)
- Refer to body repair manual section “Rear Side Outer Panel Removal and Installation” for complete information.

# BODY REPAIR INFORMATION

**NOTE:** The following content is intended only to highlight new/special concerns. No body repairs should be attempted without first referencing the appropriate body repair manual for complete information.

## USE OF HEAT DURING BODY STRAIGHTENING AND REPAIR

When you are doing body straightening and repair procedures:

- DO NOT apply heat to any body part during straightening. This may compromise the internal structure and strength of high-strength steel parts.
- Any part that has heat applied to it during straightening **MUST** be replaced with new parts.
- Ignoring these instructions may significantly reduce occupant protection in any subsequent collision.

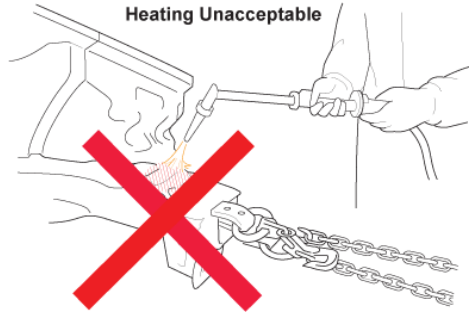

## SECTIONING (CUT AND JOINT) GUIDELINES

Various high-strength steel materials with different sheet thicknesses and strengths are applied in many places that vary by body design in order to increase collision safety performance, body stiffness, and weight reduction. Stiffening members inside each part (patch, stiffener, etc.) are also specified in detail.

Follow these guidelines to avoid an unsafe repair:

- Avoid sectioning (cut and joint) except for outer panels and floor panels unless a specific procedure is provided in the body repair manual.
- However, depending on the type of vehicle damage, steel parts with a tensile strength  $\leq 780$  MPa may be sectioned (cut and weld) under the following conditions:
  - Sectioning must be done in a single-layer area of the part.
  - Multi-layer internal steel reinforcements and stiffeners must not be cut.
  - The repair is not in a load bearing area such as engine, transmission, or suspension mounting points.

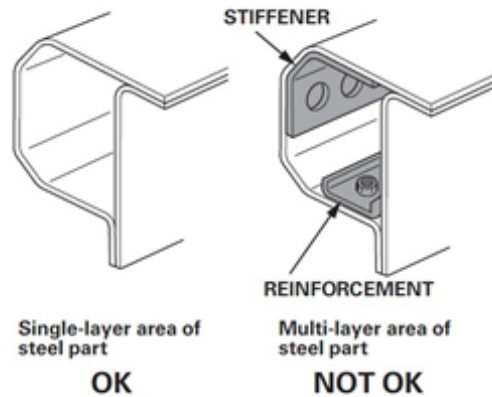

Sectioning Area Examples

- Replace body structural components such as stiffeners, reinforcements, and other multi-layered steel parts as assemblies that match the replacement parts configuration.
- Approved welding methods are listed in the table.
- Refer to the body repair manual for complete information.

Steel Part Tensile Strength (MPa)	Welding Method		
	Spot Weld	MAG Welding	
		Plug	Butt
<590	○	○	○
590	○	○	○
780	○	○	○
980	○	○	X
1500	○	X	X

Welding Methods For Steel Parts  
(○ = Approved X = Not Approved)

# WELDING PRECAUTIONS AND INFORMATION

## REPAIRING 1,500 MPa STEEL PARTS

Observe these precautions when repairing 1,500 MPa steel parts:

- NEVER attempt to straighten damaged 1,500 MPa steel parts because they may crack.
- 1,500 MPa steel parts MUST be replaced at factory seams using squeeze-type resistance spot welding (STRSW).
- MIG brazed joints should be used ONLY in locations not accessible by a spot welder.
- To assure adequate weld tensile strength, always set the spot welder to the specifications provided in the body repair manual.

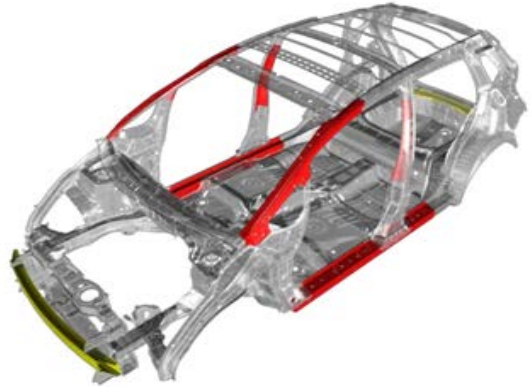

### Important Information

Parts made of Ultra High Strength Steel (UHSS/1,500MPa/ USIBOR) and must be installed as a complete part. No sectioning allowed. Ultra High Strength Steel requires special welding equipment, procedures and settings. See the welding section of the appropriate body repair manual. Failure to use the proper equipment or follow the proper procedures can result in an unsafe repair.

- NEVER perform MAG welding on 1,500 MPa steel. The heat generated during welding will significantly reduce the strength and structural integrity of 1,500 MPa steel parts.
- This photo shows tensile strength test results of welded 1,500 MPa steel. The 1,500 MPa steel fractured first, because the welding heat reduced its strength to far below 590 MPa.
- For more information, refer to “Hot Stamp (1,500 MPa) Parts Welding Specifications” in the body repair manual.



Tensile Test Results of Welded 1500 MPa Steel

## MIG BRAZING GUIDELINES FOR 1,500 MPa STEEL PARTS

Refer to the body repair manual for complete information:

- MIG brazed joint locations are specified in the body repair manual.
- A single or double hole MIG braze may be specified in the body repair manual depending on the tensile strength of the parts being joined.
- The size and number of holes is critical to achieving adequate joint strength.
- A pulsed MIG welder MUST be used. Refer to the equipment manufacturer's instructions for welder voltage and current setup.
- Photos at right show the difference in results between pulsed and non-pulsed MIG brazing.



Pulsed MIG (OK)



w/o Pulsed MIG (Bad)

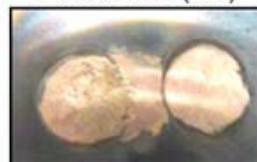

## MAG WELDING SPECIFICATIONS FOR 590-980 MPa HIGH-STRENGTH STEEL PARTS

NOTE: In this publication and the body repair manuals, gas metal arc welding (GMAW) is referred to by its subtypes depending on the welding/brazing requirements:

- MIG welding/brazing = Metal inert gas welding or brazing where 100% argon (Ar) shielding gas is used. Argon is inert and does not react with the molten weld pool or brazing operation.
- MAG welding = Metal active gas welding where the shielding gas being used contains a mixture of 80% argon (Ar) and 20% carbon dioxide (CO<sub>2</sub>). It is considered active because the CO<sub>2</sub> undergoes a limited reaction with the molten weld pool.

### Important Information

Certain parts made of High Strength Steel (590-980 MPa) must be installed as a complete part. Refer to "Parts Sectioning (Cut and Joint) Guidelines" in the body repair manual for complete information. High-strength steel requires special welding equipment, procedures, and settings. See the welding section of the appropriate body repair manual. Failure to use the proper equipment or follow the proper procedures can result in an unsafe repair.

The body repair manual specifies the weld types and locations for each body panel:

- The welding wire used must have a tensile strength equal to, or greater than, the lowest tensile strength of the parts being welded. This conversion chart shows the relationship of steel tensile strength (MPa) to the minimum welding wire tensile strength (ksi).
- Refer to the diagrams shown below:

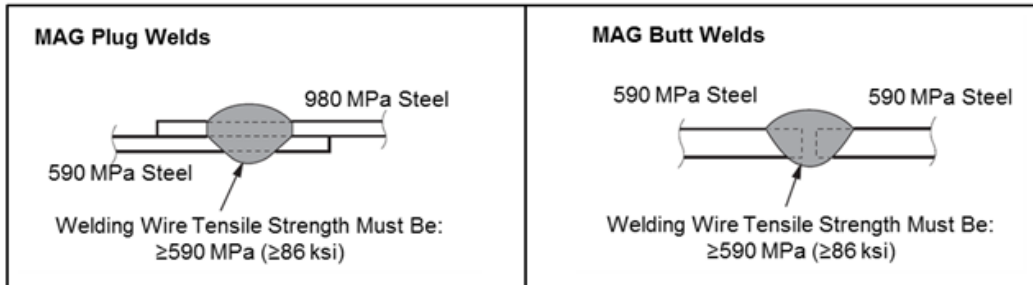

### MAG PLUG WELDING GUIDELINES

- MAG plug welding may be done when joining body components to 590-980 MPa steel parts.
- Follow the recommendations described in the body repair manual section "MAG Welding Conditions for High-Strength Steel (Except 1,500 MPa) Parts."

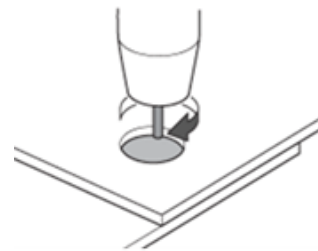

MAG Plug Welding

### MAG BUTT WELDING GUIDELINES

- MAG butt welding may only be done on steel parts with a tensile strength of 780 MPa and lower.
- Welding speed is critical to achieve the correct weld strength and minimize the heat affected zone (HAZ).
- Follow the recommendations described in the body repair manual section "MAG Welding Conditions for High-Strength Steel (Except 1,500 MPa) Parts."

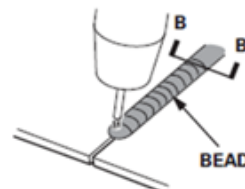

MAG Butt Welding

# AIRBAG SYSTEM COMPONENTS AND REPAIRS

## AIRBAG SYSTEM COMPONENTS

The airbag system in this vehicle includes the following components that may deploy in a collision:

- Driver and front passenger seat belt tensioners (may deploy independently from any airbags).
- Driver and front passenger SRS airbags.
- Side airbags mounted in the outer driver and front passenger seat-backs.
- Side curtain airbags mounted above the left and right side windows under the headliner.

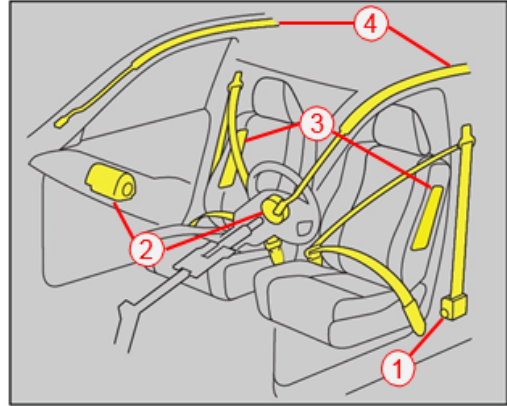

## SMARTVENT™ SIDE AIRBAGS

This vehicle is equipped with SmartVent side airbag construction:

- This airbag design helps mitigate the risk of excessive airbag deployment force and risk of injury to smaller seat occupants.
- Eliminates the need for the Occupant Position Detection System (OPDS) sensor located in the front passenger's seat-back.

As with all side airbags, the following service precautions apply:

- Special seat covers and/or breakaway thread are used. to ensure proper deployment path.
- Damaged front seat covers should be replaced, not repaired.
- Do not install non-factory seat covers, because they may alter the airbag's intended deployment path.

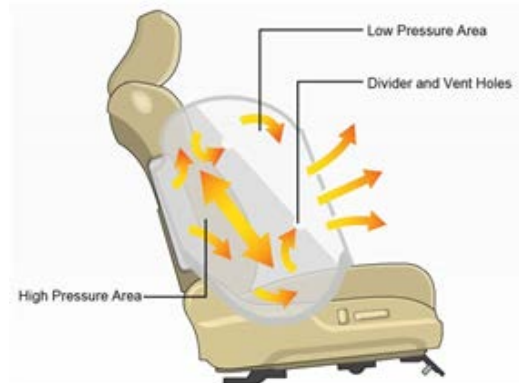

SmartVent Side Airbag



## AIRBAG SYSTEM INDICATORS

There are two indicators used for the airbag system:

### Supplemental Restraint System (SRS) Indicator

When you turn the vehicle to the ON mode, this indicator should come on and then turn off after about 6 seconds.

- If the SRS indicator does not go off, or does not come on at all, there is a problem with the system.
- DTCs must be read and cleared using the HDS (or equivalent) scan tool. Contact a Honda dealer for assistance if necessary.
- If a vehicle is sent to the dealer for airbag system repair or troubleshooting, include a copy of the repair estimate with part numbers and the source for any replaced airbag system parts.



SRS Indicator

### Passenger Airbag OFF Indicator

The indicator comes on to alert you that the passenger's front airbag has been turned off.

- This occurs when the front passenger's weight sensors detect about 65 lb. (29 kg) or less, the weight of an infant or small child, on the seat.
- If the indicator comes on with no front passenger and no objects on the seat, or with an adult occupying the seat, something may be interfering with the seat weight sensors, or there may be a problem with the system. Contact a Honda dealer for assistance if necessary.



Passenger Airbag  
OFF Indicator

## AIRBAG SYSTEM REPAIRS REQUIRED AFTER DEPLOYMENT

To restore proper function and allow DTCs to be cleared, the airbag system **MUST** be repaired as specified in the service manual. Refer to "Component Replacement/Inspection After Deployment" for details.

- DO NOT install used, refurbished, or modified airbag system parts!
- When making airbag system repairs, only use new genuine replacement parts, which are manufactured to the same standards and quality as the original parts.
- To ensure the correct replacement airbag system parts are installed, provide the vehicle's VIN when ordering parts. Compare the part numbers on the new and removed parts to make sure they match.

## AIRBAG SYSTEM ELECTRICAL REPAIRS

Except when doing electrical inspections that require battery power, always turn the vehicle to the OFF (LOCK) mode, disconnect the negative battery cable, then wait at least 3 minutes before starting work.

- For easier identification, electrical connectors that contain only airbag system wiring are yellow in color.
- Many harnesses that contain primarily airbag wiring are also wrapped in yellow tape.
- Airbag system wiring that runs in a common harness, such as a floor harness, is generally not marked.
- NEVER attempt to modify, splice, or repair airbag system wiring. If any part of the airbag system wiring is damaged, replace the affected wiring harness(es).



**NOTE:** Refer to the service manual for complete restraint systems operation, diagnostic, and repair information.

# ELECTRICAL REPAIR INFORMATION

## TIRE PRESSURE MONITORING SYSTEM (TPMS)

This vehicle is equipped with an indirect TPMS. It uses the VSA wheel speed sensors to monitor and compare tire characteristics while driving to determine if one or more tires are significantly underinflated.

The low tire pressure/TPMS indicator blinks and/or comes on if:

- The air pressure is too low in one or more tires.
- The system requires calibration or is calibrating.
- The compact spare is mounted.
- There is a TPMS problem.

TPMS calibration must be started every time you:

- Adjust the pressure in one or more tires.
- Rotate the tires.
- Replace one or more tires.
- Replace or update the VSA-modulator control unit.



Low Tire Pressure/TPMS Indicator

Refer to “TPMS Calibration ” in the service or owner’s manual for complete information. Contact a Honda dealer for assistance if necessary.

## REPLACEABLE HEADLIGHT BRACKETS

If any of the headlight assembly attachment brackets are broken, service replacement brackets are available as service parts.

A broken headlight assembly can be repaired using service brackets provided it meets the following criteria:

- No damage to the headlight assembly
- Sealing of the headlight lens and headlight housing is maintained.

These service brackets are available:

1. Upper front bracket
2. Upper rear bracket
3. Lower bracket

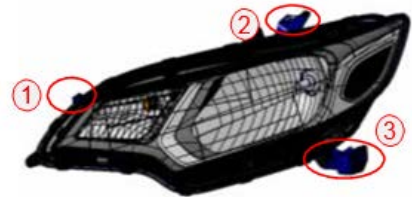

Service Headlight Brackets

Refer to “Headlight Bracket Replacement” in the body repair manual for complete information.

## SYSTEMS THAT MAY REQUIRE DEALER ASSISTANCE WITH AIMING

Some models may be equipped with one or more of the following systems that require aiming after collision repairs. Special tools are required to complete the aiming procedures. Contact a Honda dealer for assistance.

### LaneWatch™:

LaneWatch uses a camera and the center display to help drivers recognize objects in the blind spot of the passenger side door mirror.

The LaneWatch camera must be aimed after one or more of the following procedures are done:

- LaneWatch camera removal or replacement
- Door mirror removal or replacement
- Door panel removal or replacement
- Door panel body repair

LaneWatch does not set DTCs. Troubleshooting and camera aiming are done using the navigation system or center display self-diagnostics.

LaneWatch doesn’t use an indicator to inform the driver of a malfunction.



LaneWatch Camera

## ELECTRICAL GROUND WIRE PROTECTION

- Painting over electrical ground locations may cause electrical systems, such as Vehicle Stability Assist (VSA), to malfunction and set DTCs that may be difficult to diagnose.
- Protect the ground wire and the ground wire mounting hole threads with a bolt or silicone plug when priming or painting.

