

MODEL/YEAR MODÈLE /ANNÉE	DATE OF ISSUE DATE EN VIGUEUR	BULLETIN NUMBER NUMÉRO DU BULLETIN
2017 CR-V	DEC. 6, 2019	J-7-19

2017 CR-V Model Series: New Model Body Repair Information

DISCLAIMER: This publication contains a summary of new body and vehicle technology that may affect collision and other body repairs. Always refer to the service information manual and Body Repair Manual for complete repair information and precautions regarding the SRS systems, driver assist systems, welding and electrical repairs. **A subscription may be purchased at: techinfo.honda.com**

APPLIES TO: 2017 CR-V model series

OVERVIEW OF BODY FEATURES

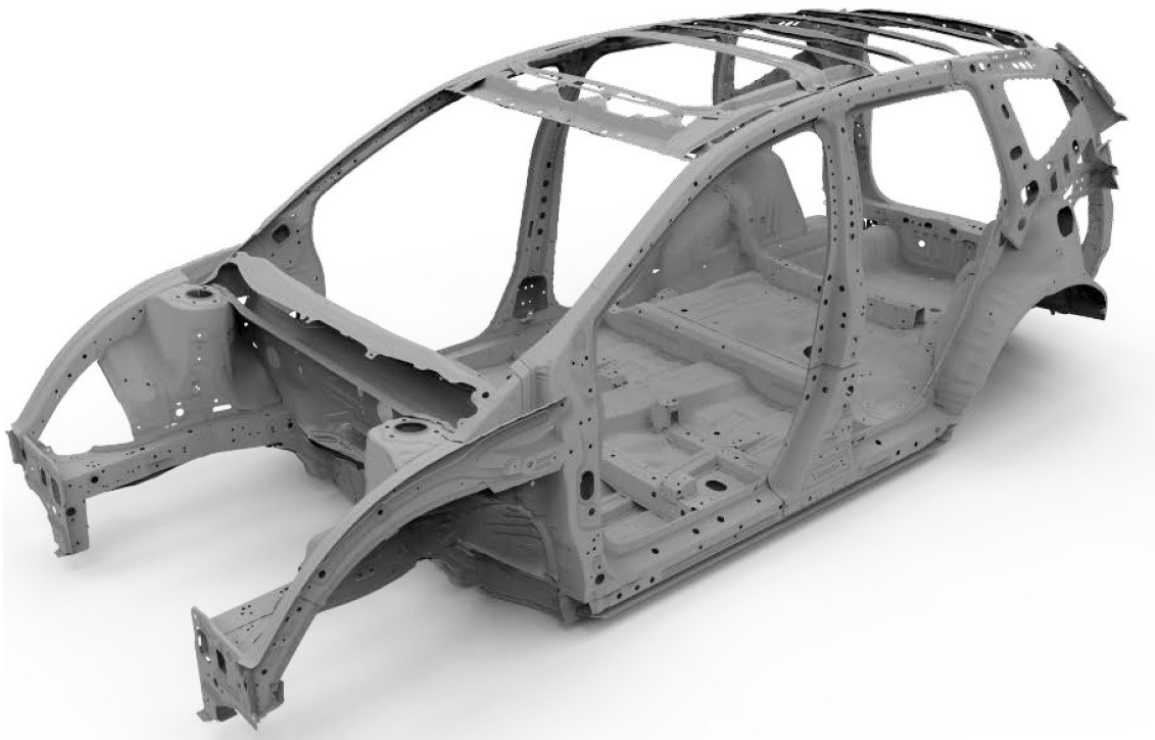

- Next-Generation Advanced Compatibility Engineering™ (ACE™) body structure
- Body construction using extensive amounts of high-tensile-strength steel (HSS), including 26% ultra-high-strength steel (UHSS - 980 MPa and higher)
- Weight-saving 1,500 MPa rear frame rails with soft zones for crash performance that may be sectioned in specified areas during collision repairs.
- Bolt-on resin composite front bulkhead assembly

NEW MODEL BODY TECHNOLOGY

BODY CONSTRUCTION AND HIGH-STRENGTH STEEL CONTENT

- Steel parts are color coded based on their tensile strength in mega Pascal (MPa).
- High-strength steel (HSS) is defined as any steel with a tensile strength of 340 MPa or higher.
- Ultra-high-strength steel (UHSS) is defined as any steel with a tensile strength of 980 MPa or higher.
- Steel repair and welding procedures vary depending on the tensile strength of the parts involved.

Upper View

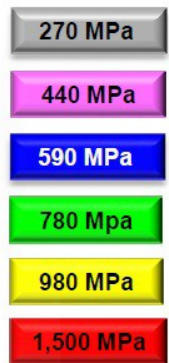
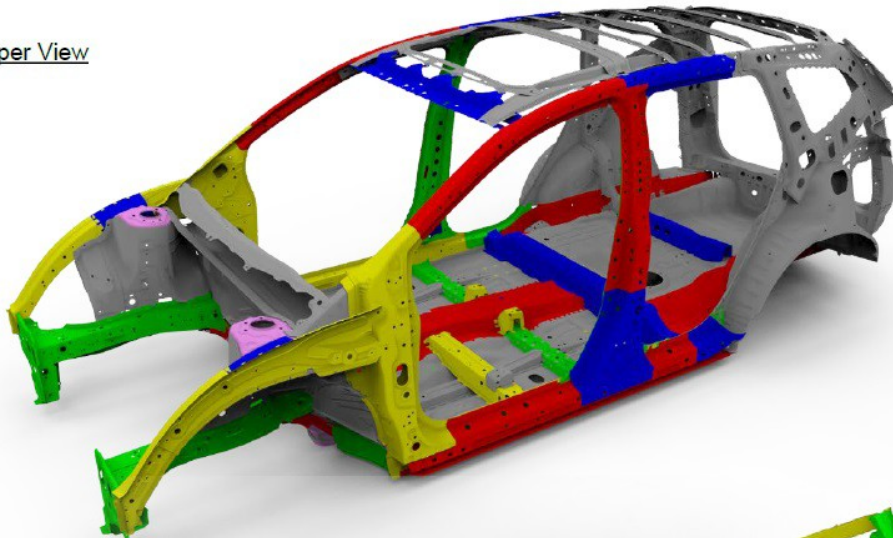

Steel Tensile Strength Legend

Lower View

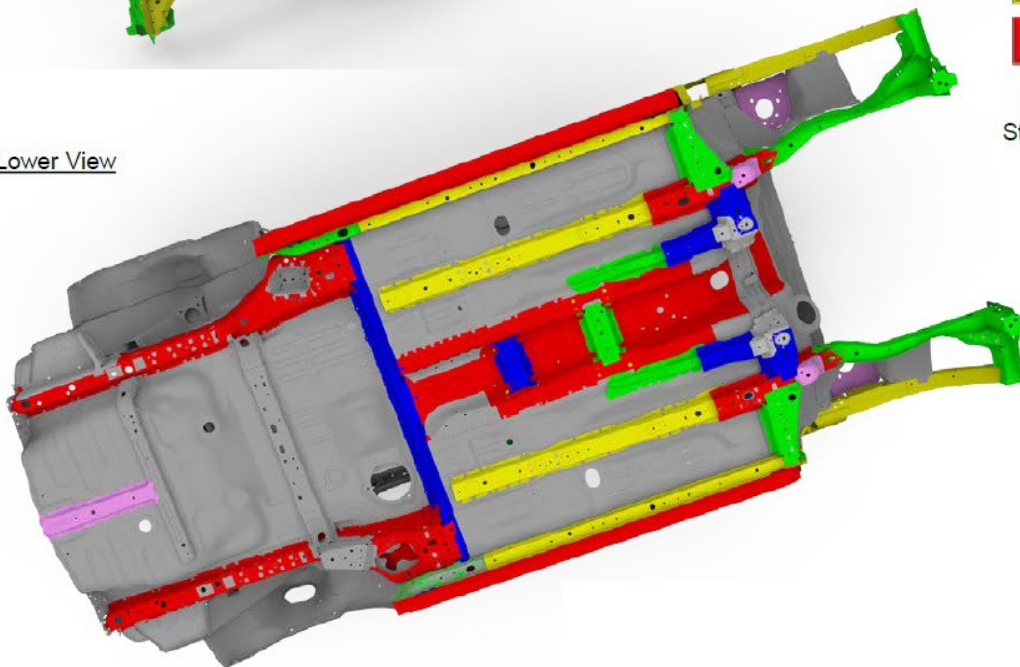

NOTE: These illustrations are for general reference only. Some body parts are constructed from multiple layers of different tensile strength steels. Always refer to the body repair manual body construction section for specific steel tensile strength information.

1,500 MPa (HOT STAMP) STEEL LOCATIONS

1,500 MPa steel is stronger than ordinary steel, so it can help protect vehicle occupants while reducing overall vehicle weight to improve fuel efficiency.

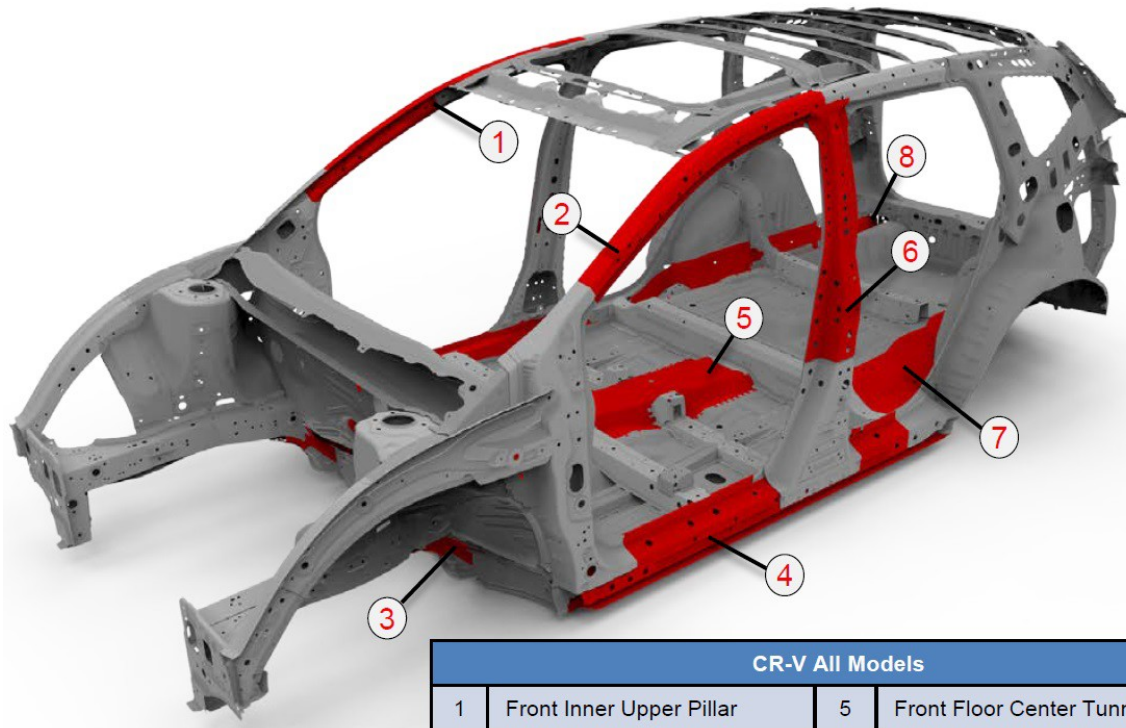

CR-V All Models			
1	Front Inner Upper Pillar	5	Front Floor Center Tunnel
2	Front Pillar Upper Stiffener	6	Center Pillar Upper Stiffener
3	Front Side Frame Extension	7	Rear Frame A
4	Side Sill Reinforcement	8	Rear Frame Upper Stiffener A&B

SECTION-ABLE 1,500 MPa STEEL REAR FRAME

All models use weight-saving 1,500 MPa steel rear frame rails with soft zones for impact crush control.

- If rear frame damage is suspected, measure the entire vehicle using a three-dimensional measuring system.
- If the rear frame is damaged, replace the affected rear frame(s) as necessary depending on the damage.
- Because of a design change to the rear frame soft zones, the rear portion of the rear frame may be sectioned and replaced as specified in the BRM Rear Floor/Rear Frame Replacement procedure.
- For further repair information, refer to Rear Floor/Rear Frame Replacement and Rear Frame Complete Replacement in the service information.

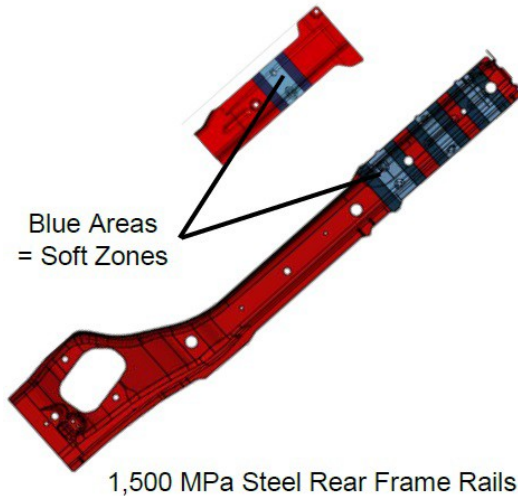

ALUMINUM PARTS & REPAIR-ABILITY

The front and rear bumper beams are constructed from aluminum alloy.



Front and Rear Bumper Beams

REPAIR-ABILITY ISSUES

- Do not repair bumper beams if they are damaged.
- To prevent galvanic corrosion, some fasteners for aluminum parts are considered one-time use and must be replaced if removed.

RESIN COMPOSITE FRONT BULKHEAD

This vehicle has a lower bulkhead assembly constructed of resin composite material.

- The bulkhead design improves engine compartment access during factory assembly and service.
- The front bulkhead is attached with multiple bolts and is sold and replaced only as a complete assembly.
- The cooling fans, radiator, A/C condenser, hood lock, outside air temperature sensor, and related piping/ components are attached to the front bulkhead using molded-in M6/M8 threaded inserts.
- Over-torqueing or using power tools may break these inserts loose, requiring front bulkhead replacement.
- A damaged bulkhead must be replaced, not repaired.
- For more information, refer to Exterior Parts Removal and Installation in the service information.



Resin Composite Front Bulkhead

DOUBLE-SIDED ADHESIVE TAPE EXTERIOR PARTS ATTACHMENT

For better appearance/function, the following exterior parts are attached using double-sided adhesive tape instead of the traditional plastic clips:

- Front door sash outer trim.
- Rear door sash outer trim.
- Rear door wheel arch protector.

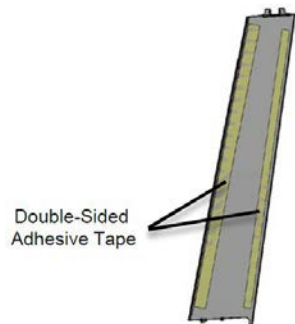

Front Door Sash Outer Trim

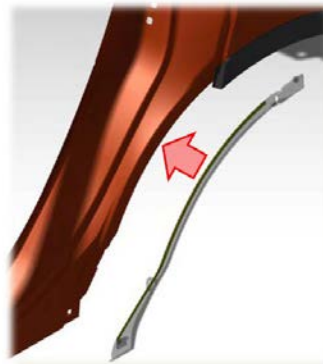

Rear Door Wheel Arch Protector

If these parts are removed, they must be replaced with new parts to ensure proper retention.

ACOUSTIC SEPARATOR LOCATIONS

A combination of molded, extruded, and tape acoustic separators are applied in various body locations.

- These are applied within the body pillars.
- Locations are shown in the diagram below.
- They are designed to block the noise paths into the cabin from hollow body cavities.
- Repairs are similar to previous models using commercially-available products.
- Refer to the Replacement section of the service information for specific procedures.

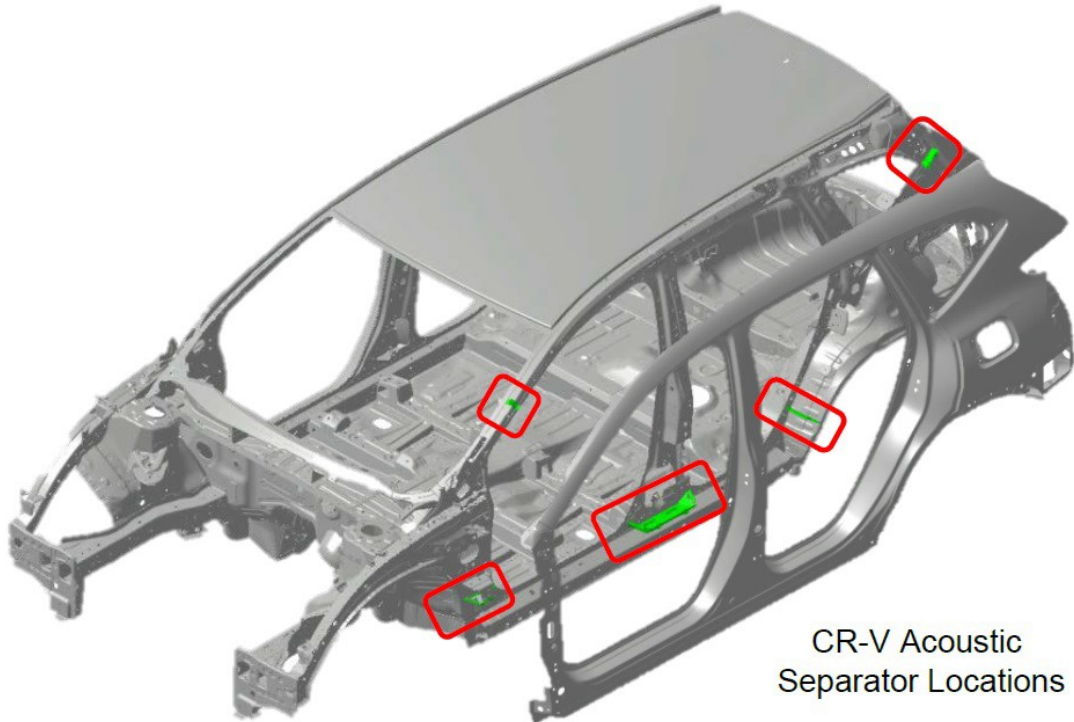

POWER TAILGATE INFORMATION

- EX-L and Touring trim levels include a spindle-type power tailgate.
- The motor and actuator are integrated into the driver's side tailgate support strut for weight reduction.
- The Touring trim level also includes a hands-free feature that is activated using a kicking motion under the rear bumper.
- Until it is reset, the power tailgate will not open or close automatically under the following conditions:
 - The battery is disconnected, or the No. 18 BACKUP (10 A) fuse in the under-hood fuse/relay box is removed while the tailgate is operating.
 - Certain power tailgate components have been replaced.
- Refer to Resetting the Power Tailgate Control Unit in the service information.



Spindle-Type Power Tailgate Actuator